



ALBANY COUNTY AIRPORT AUTHORITY

REGULAR MEETING

REVISED AGENDA

August 12, 2024

General:

- 1. Chairman's Remarks**
- 2. Approval of Minutes**
Special Meeting – July 22, 2024
- 3. Communications and Report of Chief Executive Officer**
 - ACI Survey Updates – Arturo Garcia, AvPorts Chief Operating Officer**

Reports:

- 4. Chief Financial Officer**
- 5. Project Development**
- 6. Counsel**
- 7. Concessions/Ambassador Program**
- 8. Public Affairs**
- 9. Business & Economic Development**

Action Items:

- 10. Authorization of Contracts/Leases/Contract Negotiations/Contract Amendments**
 - 10.1 Purchase Order: Request for Authorization to purchase one (1) new Front Mount Snow Blower & Chassis from M-B Companies, Inc. under Contract E-1194 (Contingent upon FAA Concurrence)**



- 10.2 Negotiations: Professional Service Contract S-1196 General Aviation Apron Reconstruction with McFarland Johnson, Inc.**
- 10.3 Purchase: One (1) 2024 Chevrolet Silverado 2500HD 4WD Crew Cab - Joe Basil Chevrolet, Inc.**
- 10.4 Approval of a contract with Capital Digitronics for the purchase and installation of radios and accompanying equipment.**
- 11. Authorization of Change Orders - None**
- 12. Authorization of Federal and State Grants**
 - 12.1 Grant Agreement: Authorization to Accept Federal Grant - Concourse A Modernization**
 - 12.2 Grant Agreement: Authorization to Accept Federal and State Grants Runway 01/19 Rehabilitation & South Perimeter Road Construction**
- 13. Informational Only - None**

Old Business:

New Business:

Executive Session - Attorney-Client Privilege Matters

AGENDA ITEM NO. 1

Chairman's Remarks

AGENDA ITEM NO. 2

Approval of Minutes



Minutes of the Special Meeting of the Albany County Airport Authority

July 22, 2024

Pursuant to notice duly given and posted, a Special meeting of the Albany County Airport Authority was called to order on Monday July 22, 2024 @ 9:00 a.m. in the 2nd Floor Conference Room at the Million Air Facility at the Albany International Airport by Chairman Samuel A. Fresina with the following present:

MEMBERS PRESENT

Samuel A. Fresina
Kevin R. Hicks, Sr.
Steven H. Heider
Sari M. O'Connor
Janet M. Thayer

MEMBERS ABSENT

John-Raphael Pichardo
Thomas A. Nardacci

STAFF

Philip F. Calderone, Esq.
Christine C. Quinn
Michael F. Zonsius
Matt Cannon
Connor Haskin
Liz Charland
John LaClair
Matt Mokey

ATTENDEES

Todd Pennington, Airport Manager, AvPorts
Carmiena Brooks, Assistant Airport Manager, AvPorts
Steven Smith, Communications Director, AvPorts
Brian King, Manager Million Air
Fire Chief Steve Dorsey, AvPorts
Jeff Lovell, Managing Director Park Strategies, LLC
Kevin Butterfield, Albany County Communications
Elizabeth Kalin, Albany County Communications
Mike Lalli, Albany County
Beth DiBattista, VP Operations, Turner Construction
Rob Wagner, Project Manager, Turner Construction
Carl Stewart, Turner Construction
Arturo Garcia, AvPorts
Perry Blanchard, AvPorts, IT
Peter Sheehan, AvPorts IT

Chair Fresina noted that there was a quorum.

General:

1. Chairman's Remarks



2. Approval of Minutes

Mr. Hicks moved to approve the May 9, 2024 Minutes. The motion was adopted unanimously.

Mr. Heider moved to approve the June 10, 2024 Minutes. The motion was adopted unanimously.

Management Reports:

No management reports at this meeting. These reports were given at the July 8, 2024 meeting. There was not a quorum on July 8 therefore action items could not be approved.

This Special meeting only consists of action items.

2. Authorization of Contracts/Leases/Contract Negotiations/Contract Amendments

2.1 Construction Contract: Authorization to Award Contract 1162-GC for RW 1-19 Rehabilitation and Lighting Upgrades to Callanan Industries, Inc.

Mr. LaClair recommended authorization to award Contract No. 1162-GC Runway 1-19 Rehabilitation and Lighting Upgrades to Callanan Industries, Inc. in the amount of \$9,492,500.00. He advised the contract scope includes milling and paving of RW 1-19, the removal of all runway lights and replacement with LED light fixtures. Additionally the contractor will use some of the removed asphalt (millings) to construct the south perimeter road to complete a full perimeter road inside the SIDA area.

Mr. Hicks moved to approve the award of Contract No. 1162-GC Runway 1-19 Rehabilitation and Lighting Upgrades to Callanan Industries, Inc. in the amount of \$9,492,500.00. The motion was adopted unanimously.



2.2 Amendment No. 1 to Professional Services Contract No. S-22-1127 Design Services for the Rehabilitation of Concourse A with Fennick & McCredie Architecture

Mr. LaClair recommended authorization to award Amendment No. 1 for Professional Services Contract S-22-1127 Design Services programmed for the Rehabilitation of Concourse A to Fennick & McCredie Architecture in the amount of \$833,755.71. He advised this Amendment is for F&M's Construction Administration (CA) for the project. The scope of work includes submittal reviews, site visits to ensure adherence to the drawings, answer all RFI's, provide a Final walk thru with a Punchlist and provide ACAA with Record drawings and all associated warranties. This contract is 70% federally and 30% airport funded.

Ms. Thayer moved to approve Amendment No. 1 in the amount of \$833,755.71. The motion was adopted unanimously.

2.3 Adoption of Plan Review and Approval of Five-Year Capital Program

Mr. Zonsius recommended approval of our Five-Year Capital Program for the years 2025-2029. He advised that included in our Enabling Legislation is the requirement that the Authority obtain approval from the Albany County Legislature of a Capital Program every five years. The Authority has met its obligation of submitting a Five-Year Capital Program covering calendar years 2020 through 2024, which includes one amendment. We are now seeking the Board's approval of the plan for the next five-year period 2025-2029 in the amount of \$283,350,280. The next action will be to present to the Mass Transit Committee and seek the Committee's approval. The Mass Transit Committee will introduce the program to the County Legislature for approval.

Ms. O'Connor moved to authorize approval of the Five-Year Capital Program for the years 2025-2029 in the amount of \$283,350,280 to be presented to the Mass Transit Committee with the Mass Transit Committee introducing the program to the County Legislature for approval. The motion was adopted unanimously.

2.4 Amendment #1 to Contract No. S-22-1129 Construction Management Services with Turner Construction Company

Mr. LaClair recommended authorization to award Amendment No. 1 for Professional Services Contract S-22-1129 (dated March 8, 2023) for Construction Management Services with Turner Construction Company in an amendment amount NTE \$3,089,287

He advised the contract is proposed to be amended as follows:



Scope of Services:

Construction Management services for the ALB Central Terminal A Renovation Project, Transformer/Switch Gear upgrades and current terminal related capital projects. The Construction Manager Shall be the Authority representative on the project, coordinate master schedules, evaluate adverse conditions, coordinate and expedite the design professionals in designing the project, review design and construction documents, prepare estimates, maintain project budget control, monitor and coordinate the construction phase, review payment applications of contractors, review and process change orders and process and coordinate close-out.

Not to exceed fee is based on a projected project duration of 27 months inclusive of all current terminal related capital projects.

Mr. Hicks moved to approve Amendment No. 1 in the NTE amount of \$3,089,287 based on a projected project duration of 27 months inclusive of all current terminal related capital projects. The motion was adopted unanimously.

3. Authorization of Change Orders

3.1 Construction Contract: Authorization to Award Change Order No. 1 for Construction Contract 21-1013-HVAC-M for Air Traffic Control Tower HVAC to Collett Mechanical, Inc.

Mr. LaClair recommended authorization to award Change Order No. 1 to Contract # 21-1013-HVAC-M for the Air Traffic Control Tower HVAC to Collett Mechanical, Inc. in the amount of \$55,700.25. He advised the contract scope includes removal of the existing non-functional HVAC equipment for the entire facility and replacing with new equipment as determined by the design engineers. He also advised the work noted in this Change Order #1 is for additional equipment replacement that was found to be required once Air handler units AHU 4-6 were completely disassembled and determined that none of the internal equipment (coils, motors fan wheel and hot water coil) were in good enough shape to be reused.

Mr. Heider moved to approve Change Order No. 1 in the amount of \$55,700.25 . The motion was adopted unanimously.

3.2 Change Order No. 9: Authorization to Award Contract Change Order #9 to Construction Contract 21-1082-GC for the Pre-TSA Terminal Expansion to MLB Construction Services, LLC.

Mr. LaClair recommended authorization to award Change Order #9 for Contract # 21-1082-GC for the Pre-TSA Terminal Expansion to MLB Construction Services, LLC in the amount of \$96,396.90. He advised this Change Order No. 9 is due to the discovery of additional underground electrical and communication



ductbanks running between the Terminal and the North Garage. Once these ductbanks were discovered, the contractor was directed to re-route the cables, this included staged excavation (to maintain continuous passenger vehicle flow for pick up and drop of) across the Terminal road, shoring of the trench for conduit installation, backfill of the trench and placement of concrete to provide a solid driving surface.

Ms. O'Connor moved to approve Change Order No. 9 in the amount of \$96,396.90. The motion was adopted unanimously.

There being no further business, the meeting was adjourned at 9:09 a.m.



ALBANY COUNTY AIRPORT AUTHORITY

SPECIAL MEETING

AGENDA

July 22, 2024

General:

General:

4. Approval of Minutes

Regular Meeting – May 9, 2024

Regular Meeting – June 10, 2024

Action Items:

2. Authorization of Contracts/Leases/Contract Negotiations/Contract Amendments

2.1 Award Runway 01-19 Rehabilitation & Lighting Upgrades – Contract No. 1162-GC – Callanan Industries, Inc.

2.2 Amendment No. 1 - Rehabilitation of Concourse A – Contract No. S-1127 – Fennick McCredie Architecture (Construction Administration)

2.3 Five-Year Capital Program Years 2025 – 2029

2.4 Amendment No. 1 to Contract No. S-1129 Construction Management Services with Turner Construction Company – Turner Construction Co.

3. Authorization of Change Orders

3.1 Change Order No. 1 - Air Traffic Control Tower HVAC Mechanical & Electrical – Contract No. 21-1013-HVAC-M - Collett Mechanical, Inc.

3.2 Change Order No. 9 – Terminal Expansion – Site Work – Contract No. - 1082-GC – MLB Construction Services, LLC

AGENDA ITEM NO. 3

Communications and Report of Chief Executive Officer

AGENDA ITEM NO. 4

Financials

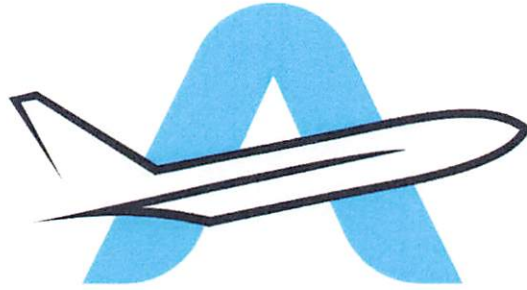

ALBANY

INTERNATIONAL AIRPORT

Monthly Financial Report

June 2024

(dated July 24, 2024)

Table of Contents

Transmittal Letter	1
Financial Report	
Statement of Net Position	4
Summary of Revenues, Expenses and Net Results	5
Schedule of Operating Revenues	6
FBO Summary of Revenues, Expenses and Net Results	7
Notes to Financial Statements	8
Schedule of Statistics	10
Schedule of Scheduled Passenger Airline Services	11
Schedule of Positions by Entity	12
Schedule of Positions by Department	13
Schedule of RFP/B Solicitations	14
Budget High/Low Revenues	15
Budget High/Low Expenses	16



July 24, 2024

ACAA Members
Philip F. Calderone, Esq.

INTRODUCTION

Changes in Enplanement, Cargo and Operations are shown below:

	2024 Current Year versus			
	2024 Month Budget	2023 Month Actual	2023 YTD	2023 Prev. 12 Mo.
Enplanements	6.9%	13.6%	10.7%	9.1%
Cargo	(15.4)	(16.2)	(6.7)	(2.4)
Operations	12.8	11.9	(0.4)	(1.4)

	Month	
	Jun23	Jun24
Destination Airports	20	20
Scheduled Monthly Flight	1,184	1,375
Average Daily Flights	39.2	45.8
Pax Lift (Pax Seats)	133,612	154,158
Enplanements	111,736	126,907

FINANCIAL INFORMATION

Cash Position – Unrestricted (Operating)

The Airport continues to maintain a strong cash position. The Statements of Net Position provided on Page 4 reports unrestricted cash of \$34,607,266 and equates to approximately 10.39 months of operating reserves (Notes to Financial Statements #2, Page 8).

Cash Position – Restricted

Restricted cash available for capital purposes is as follows:

Projects	\$ 5,782,525
Projects – PFC	10,631,025
Projects – Other	1,432,316
	\$17,845,866

Accounts Receivable

The Accounts Receivable balance is approximately 7.34 of average day total operating revenues.

Equity – YTD Earnings

The Summary of Revenues, Expenses and Net results is provided on Page 5. The Airport recorded a change in net position for the month and year-to-date shown as follows:

	Month	YTD
Airport Operating	\$ 1,566,930	\$ 7,547,167
FBO Profit	198,863	1,111,546
	1,765,793	8,658,713
Other Rev/Exp (d.ser.)	(256,107)	(1,534,545)
Capital Contributions	313,882	3,751,928
Airline Incnt. Payts.	(37,147)	(210,233)
	20,628	2,007,150
	\$ 1,786,421	\$10,665,863*

*Please note, depreciation is not recorded on the monthly financial statements.

Airport Operating Revenues

Monthly operating revenues increased approximately \$1,076K from the same month the prior year. YTD operating revenues increased approximately \$3,365K over the same time period the prior year.

Airport Operating Expenses

Monthly operating expenses were approximately \$3,015K and \$2,741K for 2024 and 2023, respectively. YTD operating expenses were \$19,290K and \$15,952K for 2024 and 2023, respectively.

AIRPORT OPERATING BUDGET

Monthly airport operating revenues were favorable to budget by approximately **\$341K**, due in large part to airline terminal space rental revenue. Monthly airport operating expenses compared to budget were unfavorable by approximately **\$293K**.

YTD airport operating revenues were favorable to budget by approximately **\$1,391K**. YTD airport operating expense were favorable by approximately **\$558K**.

MILLION AIR FBO OPERATIONS

Revenues derived from the sale of JetA and AvGas fuels is the largest contributor of FBO revenue. Below are the fuel sold in gallons for both JetA and AvGas:

	2024 Current Year versus			
	2024 Budget	2023 Month	2023 YTD	2023 Prev. 12 Mo.
JetA (gals)	23.7%	43.6%	2.7%	3.5%
AvGas (gals)	61.8	2.0	14..0	3.9

FBO Summary of Revenues, Expenses and Net results are shown on Page 7.

The FBO had operating profits of approximately **\$199K** and **\$1,112K**, for the month and year-to-date, respectively, both favorable as compared to the budget.

Monthly FBO operating revenues were favorable to budget by approximately **\$34K**. Monthly FBO COGS (cost of goods sold-fuel) compared to budget were favorable by approximately **\$21K**. Monthly FBO operating expenses compared to budget were unfavorable by approximately **\$58K**.

YTD FBO operating revenues were unfavorable to budget by approximately **\$83K**, due to deicing services. YTD FBO COGS (cost of goods sold-fuel) compared to budget were favorable by approximately **\$66K**. YTD FBO operating expenses compared to budget were unfavorable by approximately **\$78K**.

PASSENGER AIRLINE SCHEDULES

Weekly Passenger Airline schedule flight changes over the past months are as follows:

		Begin	+	-	End
Jan22	(week#22-04)	243	27	(27)	243
Mar22	(week#22-13)	248	28	(11)	265
Apr22	(week#22-17)	265	48	(5)	308
May22	(week#22-21)	308	9	(25)	292
Jun22	(week#22-26)	288	22	(14)	300
Jul22	(week#22-31)	300	27	(6)	321
Aug22	(week#22-35)	321	7	(18)	310
Sep22	(week#22-39)	310	-	(40)	270
Oct22	(week#22-44)	270	13	(6)	277
Nov22	(week#22-48)	277	4	(38)	243
Dec22	(week#22-52)	243	26	(4)	265
Jan23	(week#23-04)	265	19	(15)	269
Feb23	(week#2308)	269	36	(3)	302
Mar23	(week#2312)	302	8	(13)	297
Apr23	(week#2316)	297	12	(9)	300
May23	(week#2321)	300	6	(16)	290
Jun23	(week#2325)	290	16	(28)	278
Jul23	(week#2330)	278	28	-	306
Aug23	(week#2334)	306	2	(9)	299
Sep23	(week#2338)	299	12	(25)	286
Oct23	(week#2343)	286	25	(14)	297
Nov23	(week#2347)	297	2	(41)	258
Dec23	(week#2352)	258	10	(11)	257
Jan24	(week#2404)	257	27	(17)	267
Feb24	(week#2408)	267	27	(7)	287
Mar24	(week#2412)	287	16	(18)	285
Apr24	(week#2417)	285	15	(12)	288
May24	(week#2421)	288	12	(7)	293
Jun24	(week#2426)	293	41	(6)	328
Jul24	(week#2430)	328	1	(1)	328
Aug24	(week#2434)	328	17	(6)	339

PROJECTIONS

2024 and 2025 enplanement projections are as follows:

	2024	2025
Jan 2024	1,425,000	1,460,000
Feb2024	1,425,000	1,460,000
Mar 2024	1,425,000	1,460,000
Apr 2024	1,435,000	1,460,000
May2024	1,435,000	1,460,000
Jun 2024	1,445,000	1,460,000
Jul 2024		
Aug 2024		
Sep 2024		
Oct 2024		
Nov 2024		
Dec2024		

BOND RATINGS

Apr21	Moody's	A3	Stable
Jul23	Moody's	A2	Stable
Mar20	S&P Global Ratings	A-	Negative
Apr21	S&P Global Ratings	A-	Stable
Aug22	S&P Global Ratings	A	Stable
Fitch			Not Rated

FULL TIME FILLED POSITIONS

Workforce consists of the following Full-Time Filled positions:

	Begin	+	-	End
Jul 2022	173	-	(3)*	174
Aug 2022	174	8	(1)	181
Sep 2022	181	5	(3)	183
Oct 2022	187 ⁽¹⁾	6	(10)	184
Thru Week 50	184	-	(3)	181
Thru Week 23-02	181	-	(2)	179
Thru Week 23-06	179	-	-	181
Thru Week 23-10	181	4	(1)	184
Thru Week 23-18	184	13	(11)	186
Thru Week 23-22	186	5	(3)	188
Thru Week 23-33	188	2	(5)	185
Thru Week 23-36	185	5	(5)	185
Thru Week 23-41	185	6	(4)	187
Thru Week 23-46	187	5	(3)	189
Thru Week 23-50	189	6	4	191
Thru Week 24-03	191	7	7	191
Thru Week 24-07	191	7	2	196
Thru Week 24-11	196	2	4	194
Thru Week 24-15	194	3	1	196
Thru Week 24-20	196	5	3	198
Thru Week 24-24	198	9	8	199
Thru Week 24-28	199	3	3	199

(1) 4 position adjustment

*adjustment

COMPARISON WITH NATIONAL

Comparison of enplanement and cargo levels with the North American (NAM) amounts as provided by ACI-NA are as follows:

Enplanements

	Month YOY%		YTD YOY%		12YE YOY%	
	NAM	ALB	NAM	ALB	NAM	ALB
Jan22	90.6	188.4	90.6	188.4	104.6	137.3
Apr22	46.8	70.7	69.8	119.0	122.9	196.6
May22	31.8	38.4	59.9	93.6	101.2	161.5
Jun22	18.1	21.7	49.6	43.3	82.2	136.7
Jul22	7.8	15.1	40.3	61.0	65.5	107.1
Aug22	12.4	15.1	35.6	51.7	54.5	83.7
Sep22	18.5	10.6	33.4	31.4	47.4	21.8
Oct22	13.8	4.9	30.9	39.8	40.0	53.1
Nov22	8.4	3.3	28.5	35.7	32.8	41.6
Dec22	5.8	(0.4)	26.2	32.2	26.2	32.2
Jan23	26.8		26.8		23.8	
Feb23	17.5	15.7	22.6	18.4	20.6	18.9
Mar23	9.7	0.6	17.5	13.6	17.0	17.0
Apr23	7.1	(2.7)	14.4	8.7	14.1	12.1
May23	7.1	2.2	12.7	7.2	12.2	9.5
Jun23	7.7	(1.2)	11.8	5.6	11.4	7.2
Jul23	7.8	(0.2)	11.2	4.6	11.4	5.7
Aug23	7.7	4.8	10.7	4.6	11.0	4.7
Sep23	5.7	3.3	10.2	4.5	10.0	3.9
Oct23	7.3	11.7	10.0	5.2	9.5	4.6
Nov23	7.0	11.0	9.7	5.9	9.4	5.5
Dec23	8.5	16.4	9.7	6.7	9.7	6.7
Jan24	3.5	6.8	3.5	6.8	8.1	5.5
Feb24	7.1	11.1	5.1	9.0	7.4	5.1
Mar24	4.6	13.2	5.0	10.5	6.9	6.2
Apr24	4.0	8.2	4.8	9.9	6.7	7.1

	Cargo (tons)		YTD YOY%		12YE YOY%	
	Month YOY%		YTD YOY%		12YE YOY%	
	NAM	ALB	NAM	ALB	NAM	ALB
Sep21	3.8	(6.6)	7.1	9.3	8.4	8.5
Oct21	(0.5)	(10.6)	6.4	7.0	7.6	6.6
Nov21	4.1	0.7	6.6	6.5	7.5	6.2
Dec21	0.4	(2.1)	5.8	5.5	5.8	5.5
Jan22	(7.3)	(14.3)	(7.3)	(14.3)	4.1	3.3
Feb22	3.3	(0.3)	(2.5)	(8.0)	4.0	2.6
Mar22	(0.8)	(8.5)	(1.8)	(8.2)	2.6	0.1
Apr22	(6.7)	(24.2)	(3.3)	(12.8)	0.5	(4.6)
May22	(6.3)	(18.7)	(3.9)	(14.1)	(0.4)	(7.1)
Jun22	(3.1)	(6.8)	(3.7)	(14.6)	(0.8)	(7.8)
Jul22	(5.5)	(14.5)	(4.0)	(13.0)	(1.3)	(9.1)
Aug22	(1.1)	(0.1)	(3.7)	(11.5)	(1.7)	(9.0)
Sep22	(2.5)	(2.3)	(3.5)	(11.7)	(2.3)	(9.5)
Oct22	(5.7)	(5.6)	(3.9)	(10.0)	(2.8)	(8.3)
Nov22	(3.4)	(0.8)	(3.8)	(9.2)	(3.4)	(8.4)
Dec22	(9.2)	(3.0)	(4.2)	(8.5)	(4.2)	(8.5)
Jan23	(7.7)	(7.7)	(7.7)	(7.7)	(4.2)	(8.0)
Feb23	(6.7)	(10.3)	(7.5)	(9.4)	(5.0)	(9.4)
Mar23	(8.5)	(2.0)	(7.9)	(6.2)	(5.8)	(8.1)
Apr23	(11.0)	(2.4)	(8.7)	(5.2)	(6.0)	(6.1)
May23	(2.5)	4.6	(7.5)	(3.2)	(5.7)	(4.1)
Jun23	(6.6)	(1.5)	(7.3)	(2.9)	(6.0)	(3.7)
Jul23	(11.5)	(5.4)	(7.9)	(3.3)	(6.3)	(2.9)
Aug23	(3.1)	21.8	(7.3)	0.1	(6.6)	(1.0)
Sep23	(8.5)	(8.3)	(7.4)	(0.9)	(7.1)	(1.5)
Oct23	(7.7)	1.9	(7.5)	(0.6)	(7.2)	(0.9)
Nov23	(5.5)	4.2	(7.4)	(0.1)	(7.6)	(0.5)
Dec23	(7.1)	(4.4)	(7.3)	(0.6)	(7.3)	(0.6)
Jan24	(2.0)	(9.1)	(2.0)	(9.1)	(6.9)	(0.7)
Feb24	3.3	6.5	1.0	(1.6)	(6.1)	6.9
Mar24	(5.9)	(11.8)	(1.7)	(5.0)	(5.8)	(0.3)
Apr24	2.4	(7.4)	(0.7)	(5.6)	(4.8)	(0.7)

**Albany County Airport Authority
Statements of Net Position**

	Unaudited June 30, 2023	Unaudited June 30, 2024
<u>ASSETS</u>		
CURRENT ASSETS		
Unrestricted Assets		
Cash and cash equivalents	\$ 11,315,406	\$ 9,323,552
Development Fund	20,980,138	25,283,714
Accounts Receivable - net	2,565,177	1,283,772
Lease Receivable	2,567,186	2,722,345
Prepaid Expenses	1,341,248	889,093
Total Unrestricted Assets	38,769,155	39,502,476
Restricted Assets		
Operating and Renewal Reserves	8,283,762	9,188,543
CFC Funds	459,638	476,381
Capital Funds	10,160,184	5,782,525
PFC Funds	9,956,476	10,631,025
Revenue Bond Funds	11,267,572	13,224,517
FAA Restricted Funds	208,415	215,880
Concession Improvement Funds	714,800	740,055
Total Restricted Assets	41,050,847	40,258,926
Total Current Assets	79,820,002	79,761,402
NON-CURRENT ASSETS		
Capital Assets	273,723,538	290,050,536
Lease Receivable	18,404,031	16,969,066
Prepaid Expenses	194,232	178,797
Total Non-Current Assets	292,321,801	307,198,399
Total Assets	372,141,803	386,959,801
<u>DEFERRED OUTFLOWS OF RESOURCES</u>		
Refunding	959,399	638,650
OPEB Expenses	1,025,989	906,998
Pension Expenses	1,048,107	1,063,610
Total Deferred Outflows of Resources	3,033,495	2,609,258
TOTAL ASSETS AND DEFERRED OUTFLOWS	375,175,298	389,569,059
<u>LIABILITIES AND NET ASSETS</u>		
CURRENT LIABILITIES		
Payable from Unrestricted Assets	5,999,697	5,426,519
Payable from Restricted Assets	12,355,044	23,221,877
Total Current Liabilities	18,354,741	28,648,396
NON-CURRENT LIABILITIES		
Bonds and other debt obligations	59,817,198	51,326,409
Net OPEB Liability	6,144,431	6,470,172
Net Pension Liability - proportionate share	(189,100)	1,199,851
Total Non-Current Liabilities	65,772,529	58,996,432
Total Liabilities	84,127,270	87,644,828
<u>DEFERRED INFLOWS OF RESOURCES</u>		
Concession Improvement Funds	835,598	977,258
OPEB Expenses	1,275,576	766,596
Pension Expenses	1,246,137	75,313
Leases	20,221,742	18,721,114
Total Deferred Inflows of Resources	23,579,053	20,540,281
<u>NET POSITION</u>		
Invested in Capital Assets, net of Related Debt	215,735,782	219,244,327
Restricted	27,110,961	36,415,443
Unrestricted	24,622,232	25,724,180
Net Position	267,468,975	281,383,950
TOTAL LIABILITIES, DEFERRED INFLOWS AND NET POSITION		
	\$ 375,175,298	\$ 389,569,059

Albany County Airport Authority
2024 Summary of Revenues, Expenses and Net Results
For the six months ended June 30, 2024

	Current Month			Year to Date		
	2024 Budget	2023 Actual	2024 Actual	2024 Budget	2023 Actual	2024 Actual
AIRPORT OPERATING REVENUES						
Airline	\$ 1,289,836	\$ 1,283,541	\$ 1,629,715	\$ 7,739,019	\$ 7,732,821	\$ 9,558,377
Non-Airline	2,951,175	2,221,939	2,952,206	17,707,049	15,740,234	17,279,185
Total Revenues	4,241,011	3,505,480	4,581,921	25,446,068	23,473,055	26,837,562
AIRPORT OPERATING EXPENSES						
Personal Services	1,073,882	1,104,539	997,909	6,443,293	5,255,726	6,314,236
Employee Benefits	561,368	456,532	548,052	3,368,209	2,699,526	2,891,428
Utilities & Communications	277,108	159,913	141,569	1,662,651	1,534,272	1,243,152
Purchased Services	644,465	503,426	783,341	3,866,788	2,804,283	4,728,915
Material & Supplies	483,710	333,255	342,182	2,902,263	2,460,021	2,795,170
Office	91,116	68,552	45,137	546,694	366,286	454,126
Administration	100,155	93,319	156,801	600,928	544,533	725,260
Non-Capital Equipment	76,304	21,819	0	457,825	287,639	138,108
Total Expenses	3,308,108	2,741,355	3,014,991	19,848,651	15,952,286	19,290,395
AIRPORT OPERATING RESULTS	932,903	764,125	1,566,930	5,597,417	7,520,769	7,547,167
FBO OPERATING RESULTS	201,040	184,785	198,863	1,206,240	1,661,303	1,111,546
TOTAL OPERATING RESULTS	1,133,943	948,910	1,765,793	6,803,657	9,182,072	8,658,713
OTHER REVENUES (EXPENSES)						
Interest Earnings	66,667	142,969	226,389	400,000	765,125	1,389,458
Passenger Facility Charges	303,456	303,456	303,456	1,820,736	1,820,736	1,820,736
ACAA Debt Service	(827,785)	(835,222)	(827,785)	(4,966,710)	(5,011,332)	(4,966,710)
Line of Credit Interest	(66,667)	-	(21,068)	(400,002)	-	(45,426)
Grant Income	11,558	624,469	-	69,350	3,355,728	50,996
Insurance Recoveries	-	-	32,201	-	335,000	32,201
Improvement Charges	30,700	30,700	30,700	184,200	184,200	184,200
Total Other Revenues(Expenses)	(482,071)	266,372	(256,107)	(2,892,426)	1,449,457	(1,534,545)
INCOME/(LOSS) BEFORE CAPITAL CONTRIBUTIONS	651,872	1,215,282	1,509,686	3,911,231	10,631,529	7,124,168
AIRLINE INCENTIVES	(33,333)	(17,893)	(37,147)	(199,998)	(171,365)	(210,233)
CAPITAL CONTRIBUTIONS	-	2,330,158	313,882	-	5,139,392	3,751,928
INCREASE (DECREASE) IN NET POSITION	\$ 618,539	\$ 3,527,547	\$ 1,786,421	\$ 3,711,233	15,599,556	10,665,863
NET POSITION, BEGINNING OF PERIOD					251,869,419	270,718,087
NET POSITION, END OF PERIOD					\$ 267,468,975	\$ 281,383,950
RECONCIATION TO AIRLINE FUNDS REMAINING:						
NET RESULTS BEFORE RESERVES	651,872	1,215,282	1,509,686	3,911,231	10,631,529	7,124,168
Less: Capital Improvements	(332,701)	(287,060)	(332,701)	(1,996,206)	(1,722,358)	(1,996,206)
Less: Reserve Requirements	(107,545)	(71,443)	(107,545)	(645,269)	(428,657)	(645,269)
NET RESULTS	211,626	856,780	1,069,440	1,269,757	8,480,515	4,482,694
Revenue Sharing:						
Transfer to/from Airlines (50%)	105,813	428,390	534,720	634,878	4,240,257	2,241,347
Authority Share (50%)	105,813	428,390	534,720	634,878	4,240,257	2,241,347
Less: Airline Incentives	(33,333)	(17,893)	(37,147)	(199,998)	(171,365)	(210,233)
Net Authority Share	\$ 72,480	\$ 410,497	\$ 497,573	\$ 434,880	\$ 4,068,892	\$ 2,031,114

Albany County Airport Authority
Operating Revenues
For the six months ended June 30, 2024

	Current Month			Year to Date		
	2024 Budget	2023 Actual	2024 Actual	2024 Budget	2023 Actual	2024 Actual
AIRLINE REVENUES						
COMMERCIAL						
Landing Fees-Signatory	\$ 646,841	\$ 541,832	\$ 761,231	\$ 3,881,047	\$ 3,056,761	\$ 4,110,000
Landing Fees-Non Signatory	7,030	0	0	42,180	0	0
Airline Apron Fees	82,544	69,361	74,405	495,262	416,164	446,430
Glycol Disposal Fee	25,120	0	0	150,718	232,118	227,695
CARGO						
Landing Fees-Signatory	0	57,709	68,414	0	336,199	416,017
Landing Fees-Non Signatory	0	3,142	0	0	19,837	3,612
TERMINAL						
Loading Bridges	73,556	59,389	68,955	441,336	356,337	413,728
Space Rental	453,996	552,108	656,216	2,723,976	3,312,651	3,937,294
Non-Signatory Per Turn Fee	750	0	494	4,500	2,754	3,601
TOTAL AIRLINE REVENUES	1,289,836	1,283,541	1,629,715	7,739,019	7,732,821	9,558,377
NON-AIRLINE REVENUES						
AIRFIELD						
Tenant Maintenance	2,500	0	1,445	15,000	22,491	41,316
Total Airfield	2,500	0	1,445	15,000	22,491	41,316
TERMINAL						
Utility Reimbursement	2,000	3,720	3,667	12,000	18,797	18,477
Tenant Maintenance	1,713	350	21,875	10,280	4,150	26,820
Space Rent - Non Airline	13,011	18,851	16,410	78,068	113,715	99,045
Space Rent - Fixed Non Airline	48,329	47,130	47,130	289,974	282,777	282,777
Food & Beverage	121,125	91,593	125,500	726,750	595,601	683,256
Retail	90,250	55,583	88,958	541,500	450,767	473,852
Advertising	0	0	0	0	0	(4,300)
ATM	1,167	1,450	1,216	7,000	10,080	7,259
Operating Permits	29,256	0	27,911	175,536	150,901	190,362
Vending Machines	1,601	0	1,182	9,604	7,561	6,811
Baggage Cart Rentals	1,167	1,449	1,261	7,000	6,608	7,348
Total Terminal	309,619	220,126	335,109	1,857,711	1,640,956	1,791,706
GROUND TRANSPORTATION						
Parking	1,549,451	1,181,265	1,288,536	9,296,705	8,954,273	9,426,099
Rental Cars	546,250	389,213	774,751	3,277,500	2,234,603	2,722,151
Access Fees	16,714	913	26,403	100,283	89,807	100,073
TNCs	28,000	0	37,016	168,000	127,396	181,303
Garage Space Rent	7,187	6,911	7,188	43,124	41,467	43,125
Garage Kiosk Rent	1,800	1,800	1,800	10,800	10,800	10,800
Total Ground Transportation	2,149,402	1,580,102	2,135,694	12,896,412	11,458,346	12,483,552
OTHER AIRPORT						
Telephone System - Tenants	4,261	4,451	4,702	25,563	26,545	26,097
Building Rental	6,638	6,475	6,356	39,830	64,680	38,421
Control Tower Rental	66,210	64,595	65,887	397,262	387,572	395,323
Air Cargo Facility	91,667	44,509	109,615	550,000	256,975	657,817
State Executive Hangar	103,924	103,924	103,924	623,541	623,541	623,541
T Hangars	15,530	11,844	9,453	93,180	75,893	80,318
Tie Downs	132	252	136	793	1,513	817
Industrial Park	52,614	48,731	52,608	315,683	272,600	301,500
Land Rental	36,993	40,720	31,492	221,955	247,134	213,512
Eclipse Hangar	0	26,157	0	0	156,942	0
Hangar Rental	76,675	49,508	76,776	460,052	294,833	458,378
Antenna Space Rental	9,373	6,827	3,671	56,237	40,961	35,078
Internet and Cable Access	442	275	55	2,650	2,650	1,330
Fingerprinting	2,083	2,096	3,224	12,500	17,402	19,465
Tenant Maintenance	167	0	0	1,000	0	0
Ebay/Scrap/Equipment Sales	417	0	0	2,500	917	5,507
Utility Reimbursement	13,750	6,822	7,499	82,500	111,691	84,085
Reimb of Property Taxes	2,113	0	0	12,678	26,819	15,741
Other	6,667	4,526	4,558	40,000	9,769	5,680
Total Other Airport	489,654	421,711	479,958	2,937,925	2,618,440	2,962,611
TOTAL NON AIRLINE REVENUES	2,951,175	2,221,939	2,952,206	17,707,049	15,740,234	17,279,185
TOTAL REVENUES	\$ 4,241,011	\$ 3,505,480	\$ 4,581,921	\$ 25,446,067	\$ 23,473,055	\$ 26,837,562

June 2024 Monthly Financial Report

Albany County Airport Authority
FBO Results
For the six months ended June 30, 2024

	Current Month			Year to Date		
	2024 Budget	2023 Actual	2024 Actual	2024 Budget	2023 Actual	2024 Actual
REVENUES						
Retail Fuel						
Jet A Fuel Sales	\$ 620,833	\$ 449,913	\$ 709,624	\$ 3,725,000	\$ 2,830,617	\$ 3,054,889
AvGas Fuel Sales	35,363	55,178	54,826	212,175	198,631	225,155
Commercial AvGas Fuel Sales	1,667	2,062	2,107	10,000	8,498	8,339
Auto & Diesel Fuel Sales	24,583	12,972	11,406	147,500	136,518	143,174
Retail Fuel Sales	682,446	520,125	777,964	4,094,675	3,174,264	3,431,557
Into Plane Fees	67,500	58,160	66,545	405,000	365,015	362,805
Fuel Farm Fees	76,375	68,574	83,513	458,250	418,181	477,985
General Aviation Landing Fees	28,333	32,131	51,704	170,000	186,133	234,176
Aircraft Parking Fees	45,833	48,509	58,828	275,000	281,647	284,704
Deicing Services	124,954	0	0	749,725	1,887,685	1,222,118
FBO Properties	37,428	25,151	29,987	224,565	184,166	193,376
FBO Services	11,250	9,134	39,802	67,500	110,120	155,037
TOTAL REVENUES	1,074,119	761,785	1,108,342	6,444,715	6,607,211	6,361,758
COST OF SALES						
Fuel Costs - Jet A	311,667	209,572	378,872	1,870,000	1,448,111	1,643,266
Fuel Discounts - Jet A	25,000	9,746	14,596	150,000	77,609	91,978
Fuel Costs - SAF	0	0	0	0	0	0
Fuel Costs - AvGas	26,738	40,266	40,896	160,425	156,326	167,941
Fuel Discounts - AvGas	0	2,335	1,235	0	5,341	5,354
Fuel Costs - Commercial AvGas	1,250	1,741	1,817	7,500	7,112	7,210
Fuel Costs - Auto & Diesel	18,500	9,533	9,752	111,000	106,959	111,404
Total Fuel Costs	383,154	273,194	447,167	2,298,925	1,801,459	2,027,153
Deicing Costs - Type I & IV	94,442	0	0	566,654	1,211,712	750,185
Customs Garbage, Oil & Other	167	4,700	9,400	1,000	21,849	22,871
Total Cost of Sales	477,763	277,894	456,567	2,866,579	3,035,020	2,800,209
Net Operating	596,356	483,891	651,775	3,578,136	3,572,192	3,561,549
OPERATING EXPENSES BY CATEGORY						
Personal Services						
Salaries	150,710	127,486	190,946	904,262	794,428	989,689
Overtime	20,669	22,899	19,677	124,013	134,615	120,881
Total Personal Services	171,379	150,385	210,623	1,028,274	929,043	1,110,570
Employee Benefits	67,067	35,751	60,778	402,401	251,682	326,337
Utilities & Communications	8,507	4,835	6,438	51,044	63,233	54,326
Purchased Services	57,568	21,462	57,694	345,409	213,154	261,312
Materials & Supplies						
Buildings	11,117	3,373	5,725	66,703	61,943	45,493
Grounds	3,167	0	2,525	19,000	3,480	7,065
Vehicles	38,099	41,003	73,195	228,596	196,225	349,913
Total Materials & Supplies	52,383	44,375	81,445	314,299	261,648	402,471
Administrative Expenses	28,870	26,111	35,934	173,217	175,941	211,147
Non-Capital Equipment	9,542	16,187	0	57,252	16,187	83,840
TOTAL EXPENSES	395,316	299,106	452,912	2,371,896	1,910,889	2,450,003
FBO Net Direct Cost	\$ 201,040	\$ 184,785	\$ 198,863	\$ 1,206,240	\$ 1,661,303	\$ 1,111,546

Notes to Financial Statements

1. Accounting Basis

This financial information is presented for the purposes of comparing budget to actual results and for indicating generally how revenues and expenses have compared to budgeted revenues and expenses through on a monthly basis. The financial information presented herewith is prepared on the Albany County Airport Authority's budgetary basis of accounting.

This report includes preliminary operating and performance statistics, and financial forecasts based upon the budgetary basis of accounting estimates that involve uncertainties that could result in actual financial results differing materially from preliminary estimates.

2. Cash Reserves

2024 Operating Budget - Airport	\$40,097,302
2024 Operating Budget – FBO	<u>10,476,951</u>
	<u>\$50,574,253</u>

Monthly Operating Outflow (\$50,574,253/12)
\$4,214,521

Months Operating Reserves Unrestricted
\$34,607,266/\$4,214,521 ~ 8.21 months

Months Operating and Renewal Reserves
\$9,188,543/\$4,214,521 ~ 2.18 months

	Unrest.	Restr	Total
Jan22	6.51	2.0	8.51
Feb	6.51	2.0	8.51
Mar	6.72	2.0	8.72
Apr	6.88	2.0	8.88
May	6.95	2.0	8.95
Jun	6.93	2.0	8.93
Jul	7.26	2.0	9.26
Aug	7.65	2.0	9.65
Sep	8.03	2.0	10.03
Oct	8.26	2.0	10.26
Nov	8.23	2.0	10.23
Dec	7.94	2.0	9.94
Jan23	6.85	2.1	8.95
Feb23	7.19	2.1	9.29
Mar23	7.49	2.1	9.59
Apr23	7.36	2.16	9.52
May23	8.03	2.16	10.19
Jun23	8.44	2.16	10.60
Jul23	8.92	2.17	11.09
Aug23	9.63	2.17	11.80
Sep23	10.22	2.18	12.40
Oct23	10.41	2.19	12.60
Nov23	10.61	2.19	12.80
Dec23	11.19	2.34	13.53
Jan24	8.40	2.13	10.53
Feb24	8.36	2.14	10.50
Mar24	8.53	2.15	10.68
Apr24	8.67	2.16	10.83
May24	8.22	2.17	10.39
Jun24	8.21	2.18	10.39

3. Accounts Receivable

The amount of accounts receivables, shown as days of average annual (2023 Budget) daily revenues, is as follows:

$$\begin{aligned} \$63,781,565 / 365 &= \$174,744 \\ \$1,283,772 / \$174,744 &= 7.34 \end{aligned}$$

Jan22	14.98
Dec	3.23
Jan23	6.96
Feb	4.99
Mar	2.71
Apr	6.65
May	10.59
Jun	16.06
Jul	1.02
Aug	0.68
Sep	5.00
Oct	10.58
Nov	2.74
Dec	1.10
Jan24	13.50
Feb	13.57
Mar	15.58
Apr	14.37
May	26.09
Jun	7.34

4. Capital Assets

The following are capital expenditures that are greater than \$50,000 and have a useful life greater than one year:

	Collected
Land	\$ 48,899,432
Buildings	247,884,827
Equipment	21,685,447
Improvements	<u>295,695,571</u>
	614,165,277
Accumulated Depreciation	<u>(358,738,428)</u>
	255,426,849
Construction In Progress	
CIP – Terminal Connector	25,086,196
CIP – Other	<u>9,537,493</u>
	<u>34,623,689</u>
	<u>\$290,050,538</u>

5. FAA AIP Funding

The following are grant amounts awarded to the Authority. Revenue is recognized when expenses are submitted for reimbursement, not when they are awarded.

	Awarded	Collected
AIP141-M.Plan	\$ 751,154	\$ 644,551
AIP143-CARES	15,277,876	15,277,876 C
AIP144-CHRSSA ³	5,093,917	5,093,917 C
AIP145-CHRSSA ²	320,510	320,510 C
AIP146-Taxi A	6,256,890	6,256,890 C
AIP147-Snow Equi	1,537,634	954,635
AIP148-ARPA	12,113,224	-
AIP149-Con Relief	1,282,039	1,282,039 C
AIP150-Taxi C	7,144,824	6,430,342
AIP151-B #303 CT	2,000,000	708,156
Jobs Act of 21 ¹	28,551,945	-

¹ Bipartisan Infrastructure Law, annual appropriation \$5,568,244, award pending.

6. Line of Credit Draws

	Paid	Reimbursed
LOC24-01	Mar 8, 24 \$984,381.73	
LOC24-02	Mar 8, 24 761,816.97	Apr 2, 2024
LOC24-03	Mar 20, 24 959,955.24	Apr 9, 2024
LOC24-04	May 9, 24 2,152,308.12	Jul 1, 2024
LOC24-05	May 9, 24 1,285,737.86	Jul 1, 2024
LOC24-06	Jun 14, 24 2,586,897.15	
LOC24-07	Jun,14, 24 2,337,750.23	

Amount outstanding at July 23, 2024: \$5,909,029.11

7 Days Cash on Hand

May 23, 2024:	\$43,838,435	316 days
Jun 24, 2024:	41,022,274	296
Jul 24, 2024:	39,485,788	284
Goal		400 days

8 Airport Development Fund Balance

Feb 2024	24,413,858
Mar 2024	25,188,748
Apr 2024	27,110,625
May 2024	26,595,047
Jun 2024	25,283,714

**Albany International Airport
Statistics
For the six month period ending June 30, 2024**

	Current Month			Year to Date			12 Month Running	
	Budget	2023	2024	Budget	2023	2024	2023	2024
Total Enplanements	118,750	111,736	126,907	712,500	633,390	701,171	1,324,313	1,444,420
Operations								
<i>Passenger</i>	2,491	2,330	2,792	14,946	14,625	14,992	29,659	30,088
<i>Cargo</i>	230	236	124	1,380	1,420	886	3,164	2,210
<i>Charter, Corporate & Diversi</i>	363	376	424	2,175	2,088	2,096	4,482	4,333
<i>General Aviation</i>	1,283	1,443	1,544	7,700	6,881	6,866	14,811	14,632
<i>Military</i>	167	186	230	1,000	1,011	1,085	2,146	2,247
Total Operations	4,533	4,571	5,114	27,201	26,025	25,925	54,262	53,510
Landed Weight (000)	125,000	121,563	143,030	750,000	731,206	776,736	1,489,514	1,576,712
Cargo/Mail & Express	1,788	1,804	1,512	10,725	9,665	9,013	20,793	20,298
Jet A Gallons	116,667	100,510	144,352	700,000	584,404	599,937	1,251,575	1,294,954
AvGas Gallons	5,750	9,121	9,302	34,500	32,757	37,337	74,191	77,051
Deicing Consortium	5,417	-	-	32,500	42,745	49,880	62,999	67,757
Deicing sprayed/retail	7,000	-	-	42,000	61,312	51,582	85,306	65,917
Parking Revenue	\$ 1,549,451	\$ 1,181,265	\$ 1,288,536	\$ 9,296,705	\$ 8,954,273	\$ 9,426,099	\$ 16,675,114	\$ 17,838,366
Revenue per enplanement	\$ 13.05	\$ 10.57	\$ 10.15	\$ 13.05	\$ 14.14	\$ 13.44	\$ 12.59	\$ 12.35
Transactions		46,501	51,477		277,261	297,976	553,737	592,696
Average transaction		\$ 25.40	\$ 25.03		\$ 32.30	\$ 31.63	\$ 30.11	\$ 30.10
Concession Sales								
Rental Cars		\$ 6,878,801	\$ 7,747,515		\$ 25,336,361	\$ 27,222,435	\$ 62,379,313	\$ 65,921,200
Food and Beverage		\$ 935,206	\$ 1,042,863		\$ 4,988,321	\$ 5,646,202	\$ 10,089,869	\$ 11,214,434
Revenue per enplanement		\$ 8.37	\$ 8.22		\$ 7.88	\$ 8.05	\$ 7.62	\$ 7.76
Retail		\$ 412,731	\$ 443,028		\$ 2,262,687	\$ 2,367,499	\$ 4,577,115	\$ 4,959,638
Revenue per enplanement		\$ 3.69	\$ 3.49		\$ 3.57	\$ 3.38	\$ 3.46	\$ 3.43

SCHEDULED AIRLINE PASSENGER SERVICE

	Airlines	Non-Stop Destination Airports	Non-Stop Destination Cities ⁽¹⁾	Scheduled Flights	Average Flights per Day	Monthly Seats Available	Monthly Landed Weight (lbs.)	Enplane.	Projected Load Factor
Jan2022	7	18	13	1,066	34.4	111,340	107,337,992	74,020	66.5%
Jan2023	6	19	13	1,140	36.8	120,608	116,740,592	93,882	77.8
Jul23	6	20	14	1,298	41.9	149,717	139,876,606	125,462	83.8
Aug23	6	20	14	1,333	43.0	155,747	144,635,616	139,302	89.4
Sep23	6	19	14	1,202	40.0	135,091	126,024,544	113,844	84.3
Oct23	6	21	16	1,308	42.2	152,125	143,836,306	135,785	89.3
Nov23	6	20	15	1,172	39.1	134,799	133,262,258	114,293	84.8
Dec23	6	21	15	1,203	38.8	137,828	138,198,004	108,990	79.1
Jan24	6	20	14	1,154	37.2	129,460	131,096,230	102,258	79.0
Feb24	6	20	15	1,132	39.0	127,626	127,492,938	108,129	84.7
Mar24	6	22	16	1,249	40.3	141,947	141,120,946	122,407	86.2
Apr24	6	20	14	1,252	40.3	137,834	134,432,308	119,477	86.6
May24	6	20	14	1,295	41.7	145,241	140,610,190	123,993	85.3
Jun24	7	20	16	1,375	45.8	154,158	145,611,146	126,907	82.3
Jul24	7	20	16	1,439	46.4	162,511	154,323,352	138,279	85.1E
Aug24	7	21	17	1,459	47.1	163,229	161,600,470	138,907	85.1E

⁽¹⁾ Five (5) cities may be served by two or more airports; Chicago (ORD/MDW), New York (EWR/LGA) Orlando (MCO/SFB), Tampa (TPA/PIE/PGD), and Washington DC (DCA/IAD).

Weekly schedule flight changes are as follows:

			<u>Year-To-Date (net)</u>								
			Week		Week		Week		Week		#04-2023
			#30-2024	+	(-) #34-2024	#04-2024	+	(-) #34-2024	#04-2024		
1	ATL	Atlanta, GA	21	-	(1) 20	20	2	(2) 20	20		
2	BDL	Hartford, CT	-	-	-	-	-	-	-		
3	BWI	Baltimore, MD	32	2	- 34	30	5	(1) 34	26		
4	MDW	Chicago-Midway	19	-	(4) 15	10	9	(4) 15	12		
5	ORD	Chicago-O'Hare	41	5	- 46	24	24	(2) 46	25		
6	CLT	Charlotte, NC	28	-	- 28	21	7	- 28	20		
7	DFW	Dallas/FT Worth, TX	7	-	- 7	7	-	- 7	-		
8	DEN	Denver, CO	7	-	- 7	-	7	- 7	-		
9	DTW	Detroit, MI	27	-	- 27	21	6	- 27	-		
10	FLL	Fort Lauderdale, FL	7	-	- 7	7	2	(2) 7	6		
11	RSW	Fort Myers, FL	-	-	- -	-	1	(1) -	-		
12	LAS	Las Vegas, NV	-	4	- 4	-	4	- 4	-		
13	MIA	Miami, FL	-	-	- -	1	-	(1) -	1		
14	MSP	Minneapolis, MN	-	-	- -	-	-	- -	-		
15	MYR	Myrtle Beach, SC	3	-	- 3	-	3	- 3	-		
16	BNA	Nashville, TN	2	-	- 2	2	-	- 2	3		
17	EWR	Newark, NJ	14	-	- 14	20	-	(6) 14	14		
18	LGA	New York, LaGuardia	12	-	- 12	13	-	(1) 12	24		
19	MCO	Orlando, FL	16	6	- 22	20	9	(7) 22	15		
20	SFB	Orlando/Sanford, FL	2	-	- 2	2	4	(4) 2	2		
21	PHL	Philadelphia, PA	28	-	- 28	18	17	(7) 28	20		
22	RDU	Raleigh-Durham, NC	2	-	- 2	-	2	- 2	-		
23	PGD	Tampa/Punta Gorda, FL	2	-	- 2	2	5	(5) 2	2		
24	TPA	Tampa, FL	1	-	- 1	7	-	(6) 1	2		
25	PIE	Tampa/St. Pete, FL	3	-	(1) 2	2	3	(3) 2	2		
26	DCA	Washington DC-Reagan	26	-	- 26	20	6	- 26	26		
27	IAD	Washington DC-Dulles	28	-	- 28	20	12	(4) 28	21		
			328	17	(6) 339	267	128	(56) 339	269		

Week 28 2024
Full Time Positions

	Budget Full Time	Budget Part Time	Budget Total	Filled Full Time	Vacant Full Time
AvPORTS					
Jan22	165	15	180	132	33
Jan23	175	16	193	129	46
Thru Week 23-41	174	15	189	135	39
Thru Week 23-46	174	15	189	136	38
Thru Week 23-50	174	15	189	138	36
Thru Week 24-03	174	15	189	138	36
Thru Week 24-07	192	10	202	142	50
Thru Week 24-11	192	10	202	140	52
Thru Week 24-15	192	10	202	142	50
Thru Week 24-20	192	10	202	145	47
Thru Week 24-24	192	10	202	144	48
Thru Week 24-28	192	10	202	146	46
FBO					
Jan22	33	-	33	25	8
Jan23	36	2	38	30	7
Thru Week 23-41	36	2	38	32	4
Thru Week 23-46	36	2	38	33	3
Thru Week 23-50	36	2	38	33	3
Thru Week 24-03	36	2	38	33	3
Thru Week 24-07	36	2	38	34	2
Thru Week 24-11	36	2	38	34	2
Thru Week 24-15	36	2	38	34	2
Thru Week 24-20	36	2	38	33	3
Thru Week 24-24	36	2	38	35	1
Thru Week 24-29	36	2	38	33	3
ACAA					
Jan22	20	3	23	20	-
Jan23	20	3	23	20	-
Thru Week 23-41	20	3	23	20	-
Thru Week 23-46	20	3	23	20	-
Thru Week 23-50	20	3	23	20	-
Thru Week 24-03	20	3	23	20	-
Thru Week 24-07	20	3	23	20	-
Thru Week 24-11	20	3	23	20	-
Thru Week 24-15	20	3	23	20	-
Thru Week 24-24	20	3	23	20	-
Thru Week 24-28	20	3	23	20	-
Total					
Jan22	218	18	236	177	41
Jan23	231	21	252	179	53
Thru Week 23-36	230	20	250	183	47
Thru Week 23-41	230	20	250	187	43
Thru Week 23-46	230	20	250	189	41
Thru Week 23-50	230	20	250	191	39
Thru Week 24-03	230	20	250	191	39
Thru Week 24-07	248	15	263	196	52
Thru Week 24-11	248	15	263	194	54
Thru Week 24-15	248	15	263	196	52
Thru Week 24-20	248	15	263	198	50
Thru Week 24-24	248	15	263	199	49
Thru Week 24-28	248	15	263	199	49

Week 24 2024
Full Time Positions

	Budget Full Time	Budget Part Time⁽¹⁾	Budget Total	Filled Full Time	Vacant Full Time
10 Airfield (a)	29	2	31	20 (0 LOA)	9
20 Terminal-Custodial(b)	30	1	31	26 (1 LOA)	4
20 Terminal-Facilities(b)	11	1	12	10 (0 LOA)	1
21 Loading Bridge(b)	3	-	3	3 (0 LOA)	-
30 Parking (b)	22	5	27	14 (2 LOA)	8
30 Parking – Shuttle (b)	12	1	13	11 (0 LOA)	1
32 Landside	-	-	-	-	-
41 Operations (b)	38	-	38	18 (0 LOA)	20
42 ARFF (c)	25	-	25	25 (0 LOA)	-
43 Security	3	-	3	2	1
50 Vehicle Maint. (a)	12	-	12	11	1
59 Airport Mgmt.	7	-	7	6	1
60 FBO Comm.	11	-	11	11	0
61 FBO GA	21	2	23	18	3
69 FBO Admin (added)	4	-	4	3	1
71 ACAA	20	3	23	20	-
	248	15	263	199	49

⁽¹⁾ Does not include seasonal.

	Balance	Hire	Vacated	Balance
Jan22		2	2	
Feb		2	2	
Mar	171	2	5	168
Apr	168	3	2	169
May	169	7	3	173
June	173	4	2	175
July	175	-	2	174
Aug	174	8	1	181
Sep	181	5	3	183
Oct	183	-	2	181
Thru week 50	181	2	2	181
Thru week 23-02	181	-	2	179
Thru week 23-06	179	-	-	181
Thru week 23-10	181	4	1	184
Thru week 23-18	184	13	11	186
Thru week 23-22	186	5	3	188
Thru week 23-33	188	2	5	185
Thru week 23-36	185	5	5	185
Thru week 23-41	185	6	4	187
Thru week 23-46	187	5	3	189
Thru week 23-46	189	6	4	191
Thru week 24-03	191	7	7	191
Thru week 24-07	191	7	2	196
Thru week 24-11	196	2	4	194
Thru week 24-15	194	3	1	196
Thru week 24-20	196	5	3	198
Thru week 24-24	198	9	8	199
Thru week 24-28	199	3	3	199

- (a) CSEA 12/31/2026
- (b) SMART 10/31/2023
- (c) IAFF 03/31/2023

RFB/P/Qs Schedule

		Bid Notice	Pre Meeting	Bid Opening
Completed				
21-1082	Structural & Interior for Terminal Expansion	Aug 15	Aug 29	Oct 11
23-1160	Sweeper Replacement Brushes	Aug 24	na	Sep 26
23-1161GC	Wade Road Tree Removal	Aug 31	Sep 14	Sep 21
23-1163GC	Airfield Lighting Control and Monitoring System	Sep 21	Oct 10	Nov 07
21-1082-TSA	TSA Equipment Location	Nov 9	Nov 18	Dec 18
23	Line of Credit	Dec 04	na	Jan 09
23	RFQ - Aviation Legal Services	Jan 18 & 25		Feb 15
24	RFQ - Energy Broker Services	Feb 22		Mar 28
24	RFB - Janitorial Supplies	Feb 15		Mar 14
24	RFB - Concourse A - 1127 GC	April 18		May 29
24	RFB - Runway 01-19 Rehabilitation	May 16		Jun 20

Planned / Pending

		NOTICE DATE	OPENING DATE
24-	RFB- Fuel Farm Fire Suppression System (no bids)		NO BIDS
24-E1104	RFB-SRE Equipment	Jul 11	Aug 01
24-	RFP - Shuttle Bus Detailing Services	pending Jul	
24-1188	RFP - DESIGN AND Fabricate Display Cases (ARPa)	Jun 18	Jul 25
24-S195	RFP - Feasibility Study for Rental Car Facility	Jul 18	Aug 22
24-1165GC	RFB - Passenger Boarding Bridge Replacement A6&B6	Jul 18	Aug 15
24	RFB - NYS Vehicle Market Place, 2024 Pickup Truck	Jul 23	Aug 02
24	RFB - Aviation Fuel Supplier	Aug 01	Aug 29
24-199-F	RFB - Deicing Product	pending Sep	
24-	RFB - Credit Card Charge Services	pending Oct	

ALBANY COUNTY AIRPORT AUTHORITY
Airport and FBO Operating Variances
YTD Budget vs. Actual
For the 6 month period ending June 30, 2024

			Budget	Actual	Variance
Airport Operating Revenue					
31	03013	Economy Parking	1,132,875	1,289,513	156,638
31	01035	Glycol Disposal Fee	100,479	227,695	127,217
31	01065	NE Quad Cargo Facility	550,000	657,817	107,817
31	03011	Long Term Parking	7,500,000	7,591,862	91,862
31	03500	Tenant Maintenance	16,853	68,136	51,283
31	02020	Non-Airline Space Rental	78,068	99,045	20,977
31	02062	Operating Permits	175,536	190,362	14,826
31	03024	Off-Airport Parking Facilities	85,500	100,073	14,573
31	03410	Reimbursement of Property Taxes	2,113	15,741	13,628
31	03027	TNCs	168,000	181,303	13,303
31	09001	Fingerprinting	12,500	19,465	6,965
31	02025	Utility Reimbursement	12,000	18,477	6,477
31	09008	Ebay/Scrap/Equipment Sales	1,667	5,507	3,841
31	03405	Utility Reimbursements	82,500	84,085	1,585
31	02030	Non Signatory Per Turn Fee	3,000	3,601	601
31	02105	Telephone - Monthly Usage	0	586	586
31	02057	Baggage Cart Concession	7,000	7,348	348
31	02064	ATM Income	7,000	7,259	259
31	03200	Tie Downs	793	817	24
31	03040	Garage Space Rent	43,124	43,125	1
31	01071	Hangar Maintenance NYS Executiv	62,000	62,000	0
31	03050	Garage Kiosk Rent	10,800	10,800	0
31	02100	Telephone - Monthly Service	25,563	25,512	(52)
31	02063	Internet & Cable Access	2,650	1,330	(1,320)
31	01060	Building Rental	39,830	38,357	(1,473)
31	01070	Hanger Rental NYS Executive Hang	1,021,594	1,019,920	(1,674)
31	01055	Control Tower Rental	397,262	395,323	(1,939)
31	02056	Vending Machine Concession	9,604	6,811	(2,793)
31	02054	Advertising	0	(4,300)	(4,300)
31	03014	Employee Parking	22,580	16,675	(5,905)
31	02021	Non-Airline Space Fixed Rental	289,974	282,777	(7,197)
31	01050	Land Rental	221,955	213,512	(8,443)
31	03100	T-Hangar Rentals	93,180	80,318	(12,862)
31	03300	Industrial Park	315,683	301,500	(14,183)
31	02200	Antennae Space Rentals	56,237	35,078	(21,159)
31	02011	Rental of Boarding Bridges	441,336	413,728	(27,608)
31	09005	Miscellaneous Income	40,000	5,680	(34,321)
31	02052	Food & Beverage Concession	726,750	683,256	(43,494)
31	02012	Baggage Claim Room	1,040,186	994,304	(45,883)
31	01021	Apron Parking Fees	495,262	446,430	(48,832)
31	02053	Retail Concession	541,500	473,852	(67,648)
31	02010	Airline Space Rental	3,019,605	2,942,991	(76,614)
31	01010	Landing Fees - Commercial/Signatc	4,215,000	4,110,000	(105,000)
31	03010	Short Term Parking	641,250	527,377	(113,873)
31	02051	Rental Car Concession	3,277,500	2,722,151	(555,349)
			26,986,308	26,417,196	(569,112)
FBO Operating Revenue					
31	01540	Deicing Services-GA Retail	291,200	689,272	398,072
31	01541	Deicing Type I - Consortium	146,850	367,575	220,725
31	01550	Customer Services	67,500	155,037	87,537
31	01530	GA Landing Fees	170,000	234,176	64,176
31	01543	Deicing Type IV - Consortium	39,450	97,236	57,786
31	01542	Deicing Type IV - Sprayed	22,317	68,035	45,718
31	01521	Fuel Farm Revenues	458,250	477,985	19,735
31	01511	AvGas Fuel Sales	212,175	225,155	12,980
31	01535	GA Parking Fees	275,000	284,704	9,704
31	01513	Diesel Fuel Sales	100,000	99,614	(386)
31	01514	AvGas Fuel Sales-Commercial	10,000	8,339	(1,661)
31	01512	Auto Gas Fuel Sales	47,500	43,560	(3,940)
31	01545	Properties	224,565	193,376	(31,189)
31	01520	Into Plane Revenues	405,000	362,805	(42,195)
31	01510	Jet A Fuel Sales	3,725,000	3,054,889	(670,111)
			6,194,807	6,361,758	166,951
			33,181,115	32,778,954	(402,161)

Totals may not reconcile with financial statement due to revenue sharing and other adjustments.
June 2024 Monthly Financial Report

Airport and FBO Operating Expenses
YTD Budget vs. Actual High/Low by Category Report

For the 6 month period ending June 30/31, 2024

		Budget	Actual	Variance	Cumulative Variance
Airport Operating Expenses					
37	44005	Perimeter Security	387,773	1,188,102	(800,330)
37	44000	Public Safety	1,395,271	1,601,037	(205,766)
34	12010	Overtime 1.5	448,896	592,955	(144,059)
39	66060	Credit Card Service Charges	344,000	457,647	(113,647)
38	52051	Control Tower Maintenance	140,000	244,597	(104,597)
38	53051	NYS Police Hangar Maintenance	62,500	162,715	(100,215)
36	34000	Sewer	35,750	78,812	(43,062)
37	45000	Janitorial Services	422,084	464,473	(42,389)
38	51015	Apron Maintenance	29,500	69,832	(40,332)
36	35000	Water	49,775	88,007	(38,232)
38	52060	Building Maintenance	338,500	375,171	(36,671)
38	52010	Alarm & PA Systems	41,750	77,297	(35,547)
37	42060	Property Insurance	146,606	178,231	(31,625)
34	12020	Overtime 2.0	26,433	56,604	(30,171)
38	51057	System Maintenance & Repairs	110,000	138,042	(28,042)
38	54050	Snow Equipment Repair & Maintenanc	55,000	78,298	(23,298)
38	54045	ARFF Vehicle Repair & Maintenanc	10,000	32,196	(22,196)
35	29000	NYS Retirement	173,770	195,124	(21,354)
35	29001	TBI Retirement	164,161	183,911	(19,750)
38	52055	Cargo Building Maintenance	40,000	58,783	(18,783)
39	66062	Bank & Paying Agent Fees	6,000	23,561	(17,561)
39	66000	Dues & Subscriptions	27,828	43,701	(15,873)
38	53090	T-Hangar Maintenance	15,000	29,919	(14,919)
38	52013	CCTV Repair	30,000	43,023	(13,023)
39	55015	Hardware/Software Maint Support	300,454	312,612	(12,157)
37	46010	Public Relations	51,750	63,694	(11,944)
39	66012	Authority Management Travel & Edt	14,300	25,396	(11,096)
35	26010	Disability Insurance	62,616	72,758	(10,142)
37	49015	Consultant	24,000	33,438	(9,438)
38	52035	Plumbing Repairs & Supplies	59,500	68,857	(9,357)
37	45010	Refuse Removal Services	40,908	49,956	(9,049)
38	51010	Fencing	4,000	12,266	(8,266)
37	44030	Employee Shuttle Service	6,251	13,750	(7,499)
38	53040	Sign Expense	6,250	12,510	(6,260)
37	43000	Legal Services	25,000	31,125	(6,125)
35	24000	Medical Exams/Abstracts	10,050	16,051	(6,001)
38	52020	Baggage System	22,500	28,499	(5,999)
37	42020	Automotive Insurance	39,365	45,101	(5,737)
34	12030	Incentives	5,000	10,000	(5,000)
39	55012	Office Equipment Service Agreeemei	4,849	9,619	(4,770)
38	54070	Vehicle Shop Tools & Supplies	25,000	29,759	(4,759)
38	51055	Water District Charges	12,500	16,905	(4,405)
38	53071	Wildlife Hazard Management	17,500	20,935	(3,435)
38	54060	Mower Repair & Maintenance	8,500	11,341	(2,841)
38	52037	Pest Control	24,077	26,656	(2,579)
38	51016	Runway Painting	12,500	14,245	(1,745)
36	36060	Cable Television	6,080	7,649	(1,569)
36	36015	Telephones-Monthly Service	7,418	8,985	(1,567)
37	42010	Airport Liability	82,127	83,408	(1,281)
38	51052	Wastewater Conveyance	3,750	5,000	(1,250)
36	36035	Radio Communications	0	0	0
38	36035	Radio Communications	0	943	(942)
35	22300	Health Insurance - Vision	2,951	3,758	(808)
39	66010	Training / Travel	80,050	80,788	(738)
36	36032	Internet Access	31,140	31,844	(704)
37	44010	Armored Car Service	2,178	2,850	(672)
38	52080	Sign Expense	750	905	(155)
38	52050	US Customs	500	616	(116)
39	55050	Reference Materials	850	943	(93)
34	13000	Temporary Help	0	0	0
36	36017	Payphones Annual & Monthly Servi	0	0	0
36	36018	Payphones - Monthly Usage	0	0	0
37	41020	Rates & Charges	0	0	0
37	44020	Parking Valet Service	0	0	0
37	49010	Architectural Services	0	0	0
38	53078	Liquid Waste Disposal	0	0	0

Totals may not reconcile with financial statement due to revenue sharing and other adjustments.

Albany County Airport Authority
Airport and FBO Operating Expenses
YTD Budget vs. Actual High/Low by Category Report
For the 6 month period ending June 30/31, 2024

			Budget	Actual	Variance	Cumulative Variance
Airport Operating Expenses						
38	53085	Land Lease	7,718	7,718	0	(2,174,837)
35	22105	Other Post Employment Benefits (C	84,104	84,104	0	(2,174,837)
36	36016	Telephones-Monthly Usage	50	14	36	(2,174,801)
35	24010	Employee EAP Program	485	435	49	(2,174,752)
36	36012	Telephone - Sheriff	2,050	1,987	63	(2,174,689)
36	36011	Telephone Charges-Long Distance	255	87	168	(2,174,521)
38	52041	Fire Equipment Testing	2,164	1,918	246	(2,174,275)
39	66011	Authority Board Travel & Education	250		250	(2,174,025)
39	66002	AAAE	325		325	(2,173,700)
39	55010	Office Equipment Rental	7,739	7,386	353	(2,173,347)
37	42075	Violent and Malicious Acts	8,561	8,170	390	(2,172,957)
37	42065	Crime Insurance	4,484	4,076	408	(2,172,549)
38	53020	Fencing	500		500	(2,172,049)
35	24015	Smoking Cessation Class	600		600	(2,171,449)
39	55041	Express Mail	1,000	281	719	(2,170,730)
38	52036	Automatic Door Repairs & Supplies	6,000	5,232	769	(2,169,961)
39	55011	Copy Machine Use	850		850	(2,169,111)
39	55030	Printed Forms / Letterhead	1,400	539	861	(2,168,250)
38	51030	EMS Supplies	2,400	1,502	898	(2,167,352)
38	51011	Airfield Lighting	55,000	54,009	991	(2,166,361)
39	66014	Outside Functions	1,000		1,000	(2,165,361)
38	52059	Storage Space Rental	3,750	2,676	1,074	(2,164,287)
38	54040	Heavy Equipment Maintenance	40,000	38,762	1,238	(2,163,049)
39	66020	Tuition Reimbursement	1,250		1,250	(2,161,799)
37	42090	Fiduciary Liability	1,491		1,491	(2,160,308)
36	36010	Telephone Charges-Local	7,150	5,652	1,498	(2,158,810)
37	46020	Passenger Info Booth	66,000	64,187	1,814	(2,156,996)
39	66040	Licenses & Permits	1,925	110	1,815	(2,155,181)
35	22200	Dental Insurance	22,215	20,266	1,949	(2,153,232)
39	55040	Postage	4,500	2,423	2,077	(2,151,155)
37	42070	Public Official Liability	23,678	21,525	2,153	(2,148,999)
35	23000	Health Insurance - AFLAC	3,249	1,091	2,158	(2,146,841)
38	51054	Sewer District Charges	2,500		2,500	(2,144,341)
38	53041	Traffic Light Repairs	2,500		2,500	(2,141,841)
38	51032	Hazardous Material Supplies	3,000	190	2,810	(2,139,031)
39	55060	Office Supplies	16,383	13,488	2,895	(2,136,136)
37	42080	Cyber Liability Insurance	27,519	24,616	2,903	(2,133,233)
38	51033	ARFF Foam	2,925		2,925	(2,130,308)
38	51017	Airfield Shop Supplies	11,250	8,283	2,967	(2,127,341)
38	53070	Hazardous Waste Management	3,300		3,300	(2,124,041)
38	52063	Window Washing	33,000	29,250	3,750	(2,120,291)
38	51014	Pavement Repairs	3,750		3,750	(2,116,541)
38	53060	Dump Fees - Landfill	4,500	694	3,806	(2,112,735)
38	54022	Vehicle Communication Equipment	5,000	1,085	3,915	(2,108,820)
39	66050	Property Taxes	19,000	15,054	3,946	(2,104,874)
38	52040	Fire Equipment Services	4,188	194	3,994	(2,100,880)
35	25005	Uniform Purchases	21,758	17,636	4,122	(2,096,758)
38	54012	Oil / Grease	14,250	9,921	4,329	(2,092,429)
39	55032	Printing Outside Services	10,000	5,442	4,558	(2,087,871)
38	53045	Catch Basin Maintenance	5,000	295	4,705	(2,083,166)
38	54015	CNG Fuel	5,000	156	4,844	(2,078,322)
39	66013	Function Refreshments	7,500	2,585	4,915	(2,073,407)
38	52071	ID Tags	18,500	13,002	5,498	(2,067,909)
37	42093	Agency Fee	32,500	26,719	5,781	(2,062,128)
39	55070	Payroll Services	21,250	15,337	5,913	(2,056,215)
38	52014	Key Access System	6,250		6,250	(2,049,965)
37	42041	Environmental Liability	24,656	17,675	6,981	(2,042,984)
37	42045	Builders Risk	12,500	5,513	6,987	(2,035,997)
39	55031	Parking Ticket Stock	7,000		7,000	(2,028,997)
38	54010	Gasoline	62,500	55,498	7,002	(2,021,995)
37	46012	Artistic Exhibits	50,838	43,187	7,651	(2,014,344)
37	42095	Insurance Claims	7,750		7,750	(2,006,594)
39	55014	Computer Systems	32,150	23,490	8,660	(1,997,934)
37	47010	GIS Services	12,000	1,872	10,128	(1,987,806)
38	52034	Roof	12,500	1,219	11,281	(1,976,525)
38	51031	ARFF Supplies	44,098	32,769	11,329	(1,965,196)

Totals may not reconcile with financial statement due to revenue sharing and other adjustments.

Albany County Airport Authority
Airport and FBO Operating Expenses
YTD Budget vs. Actual High/Low by Category Report
For the 6 month period ending June 30/31, 2024

			Budget	Actual	Variance
Airport Operating Expenses					
38	52012	Card Access System	50,000	38,233	11,767
37	49060	Code Enforcement	25,000	12,841	12,159
39	66030	Advertising - Public Meetings	15,000	2,765	12,235
37	49005	Appraisal	12,500		12,500
38	52031	Electrical Repairs & Supplies	148,625	135,818	12,807
38	53048	Snow Removal Supplies	62,500	48,958	13,542
35	25000	Uniforms & Laundry	37,863	24,231	13,633
39	66061	EZ Pass Fees	82,500	67,629	14,871
38	54013	Vehicle/Equipment Tires	41,000	24,583	16,417
37	49040	Professional Management	350,000	333,333	16,667
36	33000	Natural Gas	189,183	172,255	16,929
38	54011	Diesel Fuel	95,000	77,896	17,104
36	36020	Telephone Repairs	39,075	21,108	17,967
38	54030	General Equipment Repair & Maint	78,907	60,546	18,361
37	47000	Special Studies	59,000	40,061	18,939
38	52062	Janitorial Supplies	110,561	91,267	19,294
37	49020	Engineering Services	75,000	55,206	19,794
38	54021	Vehicle Repair & Maintenance	64,000	43,934	20,066
39	55020	Office Furniture & Fixtures	26,575	6,405	20,170
36	36030	Telephone-Cellular	45,100	21,171	23,929
38	52090	Flight Information Displays	17,050	(14,630)	31,680
38	51053	Electric	100,000	64,119	35,881
38	52033	HVAC	80,250	42,130	38,120
38	53030	Pavement Repairs	45,000	2,694	42,306
38	51020	Rubber Removal	45,000		45,000
38	52032	Elevator Repairs & Supplies	57,500	9,691	47,809
34	11005	Part Time/Seasonal Salaries	113,994	64,959	49,035
37	46015	Advertising	75,000	20,800	54,200
37	41010	Financial Services	125,000	69,450	55,550
39	55016	Computer Equipment	111,694	54,944	56,750
35	26030	Workers Compensation	267,167	209,652	57,515
38	53010	Landscaping	101,750	40,630	61,120
35	26020	Unemployment Insurance	103,937	32,145	71,792
35	21000	Social Security	485,311	406,214	79,097
38	53050	Snow Removal Services	189,000	101,278	87,722
37	49070	Other Professional Services	250,000	153,969	96,031
38	51019	Snow Removal Supplies	185,000	13,328	171,672
34	11000	Salaries	5,848,970	5,589,119	259,851
35	22000	Health Insurance	1,927,973	1,624,052	303,920
41	83000	Equipment	457,825	138,108	319,717
36	31000	Electric	1,249,625	792,990	456,635
			19,848,651	19,008,399	840,252

Totals may not reconcile with financial statement due to revenue sharing and other adjustments.

Albany County Airport Authority
Airport and FBO Operating Expenses
YTD Budget vs. Actual High/Low by Category Report
For the 6 month period ending June 30/31, 2024

			Budget	Actual	Variance	Cumulative Variance
FBO Operating Expenses						
32	51111	Deicing Type I - Constortium	220,275	382,143	(161,868)	878,385
38	54075	Fuel Truck Lease	63,888	193,423	(129,535)	748,850
34	11000	Salaries	904,262	989,689	(85,427)	663,423
32	51113	Deicing Type IV - Consortium	59,175	122,553	(63,378)	680,045
41	83000	Equipment	57,252	83,840	(26,588)	753,457
35	21000	Social Security	67,634	92,328	(24,694)	728,763
38	54030	General Equipment Repair/Maint	40,208	56,325	(16,117)	712,646
39	66060	Credit Card Service Charges	112,500	127,020	(14,520)	700,126
39	66000	Dues & Subscriptions	9,100	20,660	(11,560)	688,566
37	49040	Professional Management	144,450	154,499	(10,049)	678,517
37	45000	Janitorial Services	30,576	40,593	(10,018)	668,499
36	33000	Natural Gas	13,400	21,780	(8,380)	660,119
32	51103	Fuel Costs - AvGas	160,425	167,941	(7,516)	652,603
32	51107	Fuel Costs - Diesel	75,000	81,879	(6,879)	645,724
35	29001	Retirement	7,700	13,894	(6,194)	639,530
35	25005	Uniform Purchases	12,046	18,065	(6,020)	633,510
38	52063	Window Washing	1,033	6,826	(5,793)	627,717
39	66015	Incentives	20,000	24,539	(4,539)	623,178
38	54013	Vehicle/Equipment Tires	10,500	12,593	(2,093)	621,085
38	52031	Electrical Repairs & Supplies	5,850	7,862	(2,012)	619,073
38	54070	Vehicle Shop Tools & Supplies	1,500	3,366	(1,866)	617,207
39	55015	Hardware/Software Maint Agreeeme	6,642	7,905	(1,263)	615,944
38	54031	Quality Control Equipment	3,500	4,735	(1,235)	614,709
32	51125	Oil	500	1,721	(1,221)	613,488
36	35000	Water	1,000	2,068	(1,067)	612,421
32	51112	Deicing Type IV - Sprayed	21,895	22,723	(829)	611,592
37	42041	Environmental Liability	23,717	24,461	(745)	610,847
39	55012	Office Equipment Service Agreeeme	250	762	(512)	610,335
37	42095	Insurance Claims	2,500	3,000	(500)	609,835
39	55010	Office Equipment Rental	700	1,189	(489)	609,346
38	54021	Vehicle Repair & Maintenance	1,750	2,190	(440)	608,906
37	45010	Refuse Removal Services	1,325	1,722	(397)	608,509
35	24000	Medical Exams	750	1,050	(300)	608,209
39	55030	Printed Forms/Letterhead	100	393	(293)	607,916
36	36033	Wireless	1,429	1,650	(221)	607,695
36	36035	Radio Communications	225	443	(218)	607,477
36	36030	Telephone - Cellular	0	0	0	607,477
37	46010	Public Relations	21,000	21,000	0	607,477
39	55032	Printing Outside Services	0	0	0	607,477
38	52037	Pest Control	400	320	80	607,557
36	36010	Telephone Charges-Local	87	0	87	607,644
36	36011	Telephone Charges-Long Distance	98	0	98	607,742
39	55014	Computer Systems	1,375	1,269	106	607,848
32	51108	Fuel Costs-AvGas Commercial	7,500	7,210	290	608,138
32	51126	TKS	500	0	500	608,638
38	54022	Vehicle Communications Equipmen	500	0	500	609,138
38	54011	Diesel Fuel	35,000	34,245	755	609,893
39	55016	Computer Equipment	800	0	800	610,693
35	22200	Dental Insurance	987	0	987	611,680
38	52036	Automatic Door Repairs & Supplies	1,000	0	1,000	612,680
36	36060	Cable Television	3,305	2,018	1,287	613,967
38	52032	Elevator Repairs & Supplies	1,750	404	1,346	615,313
38	52034	Roof	1,750	0	1,750	617,063
39	66010	Training/Travel	4,750	2,976	1,774	618,837
38	52035	Plumbing Repairs & Supplies	2,750	791	1,959	620,796
38	52010	Alarm & PA Systems	3,750	1,700	2,050	622,846
35	26010	NYS Disability	2,109	0	2,109	624,955
38	54010	Gasoline	6,000	3,103	2,897	627,852
34	12010	Overtime 1.5	124,013	120,881	3,131	630,983
39	55070	Payroll Services	9,500	5,806	3,694	634,677
38	52060	Building Maintenance	21,420	16,822	4,598	639,275
39	55060	Office Supplies	7,500	2,889	4,611	643,886
36	31000	Electric	31,500	26,367	5,133	649,019
35	26020	Unemployment Insurance	14,384	9,146	5,238	654,257
35	25000	Uniforms & Laundry	7,825	1,860	5,965	660,222
32	51105	Fuel Costs - Auto Gas	36,000	29,525	6,475	666,697

Totals may not reconcile with financial statement due to revenue sharing and other adjustments.

Albany County Airport Authority
Airport and FBO Operating Expenses
YTD Budget vs. Actual High/Low by Category Report
For the 6 month period ending June 30/31, 2024

			Budget	Actual	Variance
FBO Operating Expenses					
38	52033	HVAC	13,500	5,571	7,929
38	52062	Janitorial Supplies	13,500	5,198	8,302
38	53078	Liquid Waste Disposal	19,000	7,065	11,935
37	42060	Property Insurance	31,500	14,036	17,464
38	54040	Heavy Equipment Maintenance	65,750	30,987	34,763
32	51110	Deicing Type I - Sprayed	265,309	222,767	42,542
32	51102	Jet A Discounts	150,000	91,978	58,022
37	42010	Airport Liability	90,342		90,342
35	22000	Health	288,966	189,995	98,971
32	51101	Fuel Costs - Jet A	1,870,000	1,643,266	226,734
			5,238,475	5,197,025	41,451

Totals may not reconcile with financial statement due to revenue sharing and other adjustments.

AGENDA ITEM NO. 5

Project Development

AGENDA ITEM NO. 6

Counsel

AGENDA ITEM NO. 7

Concessions/Ambassador Program



Monday, August 12, 2024

Concessions & Ambassador Program Report

Minority Percentages in the Concessions Workforce

Date	Min/Total	HMSHost	OHM	Paradies	Dunkin
July 2023	86/144=60%	26/54=48%	48/58=83%	9/26=34%	3/6=50%
August 2023	75/118=64%	26/46=57%	33/39=85%	13/27=48%	3/6=50%
September 2023	74/124=59%	33/59=56%	26/34=76%	11/24=45%	4/7=57%
October 2023	87/134=65%	34/60=57%	38/43=78%	11/24=46%	4/7=57%
November 2023	76/118=65%	33/56=59%	28/33=85%	12/23=52%	3/6=50%
December 2023	82/124=66%	35/58=60%	30/36=83%	14/24=58%	3/6=50%
January 2024	83/131=63%	35/58=60%	31/40=77%	14/26=54%	3/7=43%
February 2024	83/128=65%	34/60=57%	32/37=86%	13/25=52%	4/6=67%
March 2024	91/136=67%	39/65=60%	34/41= 90%	15/24=62%	3/6=50%
April 2024	89/138=64%	37/65=57%	38/42=90%	10/25=40%	4/6=67%
May 2024	89/137=65%	39/63=62%	35/43=81%	12/25=48%	3/6=50%
June 2024	81/131=62%	36/62=58%	31/40=77%	10/22=45%	4/7=57%
July 2024	84/134=63%	39/63=62%	31/41=75%	9/22=41%	5/8=62%

2024

Month	Concession Revenue	Enplanements	Revenue Per enplanement
January	\$1,103,915	100,258	\$11.00/enp
February	\$1,173,876	108,129	\$10.85/enp
March	\$1,426,460	122,407	\$11.65/enp
April	\$1,389,312	119,477	\$11.63/enp
May	\$1,426,573	123,993	\$11.50/enp
June	\$1,485,891	126,907	\$12.00/enp
July			
August			
September			



Ambassador Program 2024 Totals

Tours												YTD
Jan	Feb	Mar	Apr	May	Jun	Jul	Aug	Sep	Oct	Nov	Dec	
0	0	1	2	4	2	1						10

Canines												
3128	4536	4977	5539	4945	5345	5603						34,073

Ambassador Hours												
745	749	815	865	941	711	774						5600

Guests Served												
6257	4804	7471	7032	9049	7646	8462						50,721

Ambassador Shifts												
240	258	280	269	340	156	285						1828

Business Center												
137	119	150	161	167	162	199						1095

AGENDA ITEM NO. 8

Public Affairs

AGENDA ITEM NO. 9

Business & Economic Development

AGENDA ITEM NO. 10

**Authorization of Contracts/Leases/Contract
Negotiations/Contract Amendments**

AGENDA ITEM NO. 10.1

Purchase Order: Request for Authorization to purchase one (1) new Front Mount Snow Blower & Chassis from M-B Companies, Inc. under Contract E-1194 (Contingent upon FAA Concurrence

AGENDA ITEM NO: 10.1
MEETING DATE: August 12, 2024

ALBANY COUNTY AIRPORT AUTHORITY
REQUEST FOR AUTHORIZATION

DEPARTMENT: *Planning and Environmental*

Contact Person: *Connor Haskin, ENV SP, Chief Airport Planner*

PURPOSE OF REQUEST:

Purchase Order: Request for Authorization to purchase one (1) new Front Mount Snow Blower & Chassis from M-B Companies, Inc. under Contract E-1194 (Contingent upon FAA Concurrence)

CONTRACT AMOUNT:

Total Contract Amount: \$913,529

BUDGET INFORMATION:

Anticipated in Current ALB Capital Plan: Yes ✓ No ___ N/A
Funding Account No.: 00390-90-2009

FISCAL IMPACT - FUNDING (Dollars or Percentages)

Federal* 64% State 5% Airport 31%
Term of Funding: 2021 (FAA Fiscal Year)
Federal AIP Grant No.: 3-36-0001-147-2021; NYSDOT Grant Pin No.: N/A;

JUSTIFICATION:

The Authority conducted an open competitive bid for one (1) Airport Carrier Vehicle High Speed Snow Blower. The M-B Companies, Inc. proposal resulted in the lowest competitive bid under Contract Bid # E-1194. The vendor bid meets the minimum specifications as outlined in the bid documents. This equipment purchase is three of three items of snow removal equipment being funded from AIP Grant 3-36-0001-147-2021. Approval of this request will be contingent on the Federal Aviation Administration's (FAA) concurrence with M-B Companies' Buy America Preference Requirements compliance.

**Additional federal funding will be requested during closeout of FAA Grant 3-36-0001-147-2021*

AGENDA ITEM NO: 10.1
MEETING DATE: August 12, 2024

PROCUREMENT DEPARTMENT APPROVAL:

Procurement complies with Authority Procurement Guidelines and Chief Financial Officer has approved. YES ✓ N/A

CHIEF EXECUTIVE OFFICER'S RECOMMENDATION:

Recommend approval.

FINAL AGREEMENT SUBJECT TO APPROVAL BY COUNSEL: YES ✓ NA

BACK-UP MATERIAL:

Please refer to the attached:

- *Certified copy of Bids Received; and*
- *Bid Submitted by M-B Companies, Inc.*

CONTRACT #E-1194

Purchase of one (1) 2024 or newer Airport Carrier Vehicle with High Speed Snow Blower

Company Name	M-B Companies
Addendums #1	X
Minimum Specifications Met	NO
Base Bid Price	\$900,529.00
Shipping/Delivery Cost	\$13,000.00
Total	\$913,529.00
Offerer Disclosure	X
References	X
Non-Collusion	X
Acknowledgment	X

I, Bobbi Matthews, certify that this bid tabulation is a true copy of the prices submitted by each bidder for the construction project shown above.

Albany Airport Authority Purchasing Department



Bobbi Matthews
Purchasing Agent

Sworn to before me this 1st day of August 2024

Notary Public

JENNIFER A. MUNGER
Notary Public, State of New York
No. 01MU6246332
Qualified in Schenectady County
Commission Expires Aug. 08, 2027

**Albany International Airport
Albany County Airport Authority
Albany, NY**

CONTRACT # E-1194

Airport Carrier Vehicle With High Speed Snow Blower

Bid Opening Date: August 1, 2024, 11:00 A.M., (EST)

**M-B Companies, Inc.
201 MB Lane
Chilton, WI 53014
920-898-1011**

ORIGINAL

**Albany International Airport, Albany County Airport Authority
Albany, NY, CONTRACT # E-1194,
Airport Carrier Vehicle With High Speed Snow Blower,
Bid Opening Date: August 1, 2024, 11:00 A.M., (EST)**

July 29, 2024

Albany County Airport Authority
Purchasing Office
22 Jetway Drive
Albany, New York 12211-1057

Dear Sir / Madam:

Thank you for allowing the M-B Companies, Inc. to bid on this project.

M-B Companies confirms that the equipment proposed in this bid meets or exceeds the applicable standards of the FAA Advisory Circular 150/5220-20A and SAE ARP5539.

We have been designing, manufacturing, integrating, and servicing Airport snow removal equipment for many years with great success. The enclosed customer reference listing prominent airports can attest to the fact that M-B has successfully provided similar equipment required in the bid specifications.

M-B Companies, Inc. will stand behind your equipment and will support your efforts. Please check our website at www.m-bco.com where a history of our 100-year tradition is described. All questions, concerns, issues or omissions that need to be addressed can be forwarded to me. My direct telephone number is 920-898-1011. Thank you again for allowing us to participate in this project.

Sincerely,



Joshua Abler
Inside Sales Manager MB
M-B Companies, Inc.

Capabilities Statement

About MB

Since 1907, M-B Companies has been committed to providing airport maintenance departments across the country with reliable snow removal equipment. Since 2017, MB is a brand of the Aebi Schmidt Group, a global leader of intelligent solutions for the treatment of mission critical infrastructure areas and demanding terrain.

We take pride in quality, as well as in continuous improvement, of our customer service and manufacturing processes. In 2021, our production facility in Chilton was substantially modernized, enabling us to improve process flows throughout the facility with increased crane capabilities, fabrication and assembly areas, as well as shipping and receiving areas, cutting-edge automated paint and powder coating finishing lines—all leading to increased production, safety and more efficient performance.

Our Products & Services

M-B Companies has successfully filled many large and small orders of snow removal equipment for all sizes of airports around the world. We boast a full line of airport maintenance equipment with only a small reliance on outside OEM supplier support. To satisfy your snow removal and sweeping needs, we offer blowers, plows, brooms (tow behind and truck mounted), sanders, spreaders, deicers, multi-purpose and multi-tasking configurations on a large variety of heavy-duty truck chassis.

We maintain a crew of dedicated factory trained field service technicians available for deployment to your airport when needed, usually within 24 hours. Our technicians conduct all deliveries and training on the new equipment. We provide operator training and different levels of technician training as needed to provide optimum performance of your equipment throughout its service life cycle.

M-B Companies, Inc.
Airport Maintenance Products
 201 MB Lane | Chilton, WI 53014
 Phone: +1 800 558 5800 | Fax: +1 920 849 2629
 www.m-bco.com

Doug Blada | General Manager MB Airport
 +1 920 898 1005 | doug.blada@aebi-schmidt.com

Sales
Alan Luke | Sales MB Airport, Eastern Region
 +1 804 306 5550 | alan.luke@aebi-schmidt.com

Jessie Carr | Sales MB Airport, Western Region
 +1 920 242 4134 | jessie.carr@aebi-schmidt.com

Josh Abler | Manager Inside Sales MB Airport
 +1 920 898 1011 | josh.abler@aebi-schmidt.com

Parts/Service
Aaron Schulz | Manager After Sales Spare Parts MB Airport
 +1 920 898 1022 | aaron.schulz@aebi-schmidt.com

Steve McDermott | Manager Field Service MB Airport
 +1 920 483 0288 | steve.mcdermott@aebi-schmidt.com



MB Airport Maintenance Products production facility and Aebi Schmidt Group North America Headquarters-Chilton, WI

Our Values

					
RESULTS ORIENTED	INNOVATION	INTEGRITY	PASSION	CUSTOMER FOCUSED	COLLABORATION
We contribute and add value to the Aebi Schmidt Group.	We break new grounds.	We strive for long-term relationships.	We are part of a winning team.	We improve the performance of our customer.	We strive together for one common goal.

Professional Organization Affiliations:



ALBANY COUNTY AIRPORT AUTHORITY
ADDENDUM
Number 1

DATE: July 29, 2024

CONTRACT #E-1194
Purchase of one (1) Airport Carrier Vehicle With High Speed Snow Blower

The following addendum shall be added to the original bid documents.

The questions below have been submitted. Answers are given.

- Q: Can the delivery date of August 1, 2025 be adjusted to reflect 500 days after receipt of order?
- A: Bidders can list exceptions under EXHIBIT D / Bid Sheet. Exceptions will be considered as part of the evaluation.

- Q: The Request for Bid document states that the unit must be certified for both aeronautical and on public roads. Can this be clarified?
- A: The unit MUST be certified for aeronautical roads.

- Q: The mobile radio for this unit is TBD at a later date. Can you provide the make and model for the required radio.
- A: This information is not available at this time.

- Q: There is a minimum of 500 horsepower at 1800 to 2100 rpm and developing a minimum of 1,700 foot pounds of torque at 1200 to 1400 rpm. Is 496 horsepower acceptable?
- A: Yes, minimum of 496 horsepower at 1800 to 2100 rpm and developing a minimum of 1,700 foot pounds of torque at 1200 to 1400 rpm.

- Q: The specifications for this equipment (Page 31, Engine / Transmission) states diesel particulate filtration (DPF) for emission control is not preferred for this engine configuration. If one engine requires DPF for emission control, it is our preference that is to be used on the auxiliary engine. Can "or manufacturer's standard design" be included?
- A: Yes. If one engine required DPF for emission control, it is our preference that is to be used on the auxiliary engine or manufacturer's standard design.

**ALBANY COUNTY AIRPORT AUTHORITY
NOTICE OF INVITATION FOR BIDS**

Airport Carrier Vehicle with High Speed Snow Blower

The Albany County Airport Authority (“Authority”), Albany, New York is seeking bids from qualified companies to provide One (1) 2024 or Newer Airport Carrier Vehicle with High Speed Snow Blower for use at Albany International Airport (“Airport”). The Authority seeks to purchase new, excellent, affordable, quality equipment.

A formal Request for Bid (“RFB”) will be available **July 11, 2024**, at the Office of the Albany Airport Purchasing Agent, 22 Jetway Drive, Albany, New York 12211-1057 or by downloading the document on Bid Net Direct at [www.bidnetdirect.com// albany-county-airport-authority](http://www.bidnetdirect.com//albany-county-airport-authority) . No Bid shall be considered unless the organization making the proposal has first obtained a copy of the RFB. Specific Detail of the qualification and scope of services are provided in the RFB.

The Bidder’s qualifications, cost and compliance with the requirements of the Authority will be used during the evaluation process in determining the equipment that best serves the requirements of the Authority.

All bidders must comply with Standard Clauses under New York State and Federally Aided Transportation Project Guidelines.

Participation by Minority and Women Business Enterprises, Service Disabled Veterans Owned Businesses, and Disadvantaged Business Enterprises are encouraged.

Responses to this IFB must be received no later than **11:00 AM (EST) August 1, 2024**, in the Office of the Authority Purchasing Agent.

The Authority reserves the right to reject any and all bids received, in whole or in part, to waive any and all informalities, and to disregard all non-conforming, non-responsive, or conditional bids.

TABLE OF CONTENTS

		<u>Pages</u>
SECTION I	INTRODUCTION	1
SECTION II	SCHEDULE - KEY EVENTS	1
SECTION III	OVERVIEW OF ALBANY AIRPORT	
	A. The Airport	2
	B. The Authority	2
	C. Air Transportation Area Served	2
SECTION IV	BID PROCESS	
	A. Interpretation of Bid Document	3
	B. Addenda	3
	C. Bid Due Date	3
	D. Late Bids	4
	E. Altering Bids	4
	F. Withdrawal of Bid	4
	G. Exclusion	4
	H. No Submittal	4
	I. Vendor Protest Policy	5
SECTION V	BID EVALUATION PROCESS	
	A. Evaluation Criteria	6
	B. Evaluation of Bids	6
	C. Disqualification of Bidders & Rejection of a Bid	7
	D. Rights to Accept or Reject	7
	E. Final Selection	8
	F. Additional Information	8
SECTION VI	BID SUBMISSION REQUIREMENTS	
	A. Minimum Qualifications	9
	B. Important Notice	9
	C. Submittal	10
	D. Documentation	10
	E. Bid Deposit	10
	F. Submittal Requirements	10
EXHIBIT A	NEW YORK STATE FINANCE LAW CHAPTER 56 OF THE CONSOLIDATED LAWS	12
EXHIBIT B	CONTRACTUAL TERMS AND CONDITIONS	
	A. Contract/Agreement	23

	B. Purchase Order	23
	C. Contract Administration	23
	D. Performance Terms and Conditions	23
	E. Payments	24
	F. Other Terms and Conditions	24
EXHIBIT C	Minimum Technical Specifications	28
EXHIBIT D	DOCUMENTS REQUIRED TO BE SUBMITTED WITH BID	
	1. Bid Acknowledge Form	43
	2. Offerer Disclosure of Prior Non-Responsibility Determinations	44
	3. Non-Collusion Affidavit	46
	4. References	48
	5. Bid Sheet(s)	49
	6. Exceptions (To be submitted by bidder)	51
	7. Buy American Certification	52
	8. Certifications	54
	9. Receipt of Addenda	58
	10. Iranian Energy Sector Divestment Statement	59
	11. Compliance with Iran Divestment Statement	61
	12. Operational Standards and Compliance Testing	63
EXHIBIT E	New York State Department of Transportation Standard Clause For New York State Contracts	
EXHIBIT F	Federal Contract Provision Guidelines for Obligated Sponsors & Airport Improvement Program (AIP) Projects	

ALBANY COUNTY AIRPORT AUTHORITY
Airport Carrier Vehicle with High Speed Snow Blower

SECTION I: INTRODUCTION

The Albany County Airport Authority (the “Authority”) hereby solicits sealed competitive bids from vendors to supply (1) one 2024 or newer airport carrier vehicle with high-speed snow blower for use at Albany International Airport (the “Airport”).

It is the purpose of this Invitation For Bids (“IFB”) to select a vendor to provide the equipment that will best satisfy the requirements of the Airport.

This IFB does not commit the Authority to pay any costs incurred in the preparation of bids. Further, the Authority reserves the right to accept or reject any or all bids or any part of a bid if it is in its best interest to do so.

Any information contained in this IFB is for informational purposes only and is subject to verification by the bidder.

SECTION II: SCHEDULE

The anticipated schedule of key events with regard to this IFB process is as follows:

IFB Issued	July 11, 2024
Bid Due Date	August 1, 2024 at 11:00 AM (EST)
Authority Selection	September 2024

The Authority reserves the right to revise these dates.

SECTION III: OVERVIEW OF ALBANY AIRPORT

A. The Airport

The Airport is owned by the County of Albany (the “County”) and is occupied and operated by the Authority under an Airport Lease Agreement with the County.

B. The Authority

The Authority is a public benefit corporation established and existing pursuant to the Albany County Airport Authority Act, constituting Title 32 of Article 8 of the New York State Public Authorities Law. The State of New York created the Authority in 1993 and empowered it, among other things, to promote the strengthening and improvement of the Airport and to facilitate the financing and construction of the Terminal Improvement Program (TIP) and other capital programs, and gave the Authority the power to manage, operate, maintain, and improve the Airport.

C. Air Transportation Area Served

The Airport is the sole provider of commercial air transportation serving the eastern upstate region of New York State, including the City of Albany, the Capital of the State of New York. The Airport’s primary air trade area (the area from which the Airport draws the majority of its passengers) encompasses 11 counties in eastern New York State, which include the Albany-Schenectady-Troy and Glens Falls Metropolitan Statistical Areas, as well as Berkshire County, Massachusetts and Bennington County, Vermont. As of December 31, 2019, the Airport had scheduled passenger service provided by seven of the nation’s major airlines and two all-cargo carriers. In addition, the Airport provides service to military aircraft and general aviation, including recreational and corporate users. The Airport serves primarily origin and destination (“O&D”) passenger traffic. In 2022, approximately 2.4 million passengers used the Airport.

SECTION IV: INVITATION FOR BIDS (IFB) PROCESS

A. Interpretation of Bid Document

1. If discrepancies or omissions are found by any prospective bidder or if there is doubt as to the true meaning of any part of this IFB, a written request for a clarification or interpretation shall be submitted in writing by email within 5 business days prior to the due date to the Authority's Purchasing Agent, Bobbi Matthews at bmatthews@albanyairport.com
2. The Authority is not responsible for any explanation, clarification, interpretation or approval made or given in any manner except by written Addendum. A copy of each Addendum will be posted on Bid Net Direct. If a vendor received a copy of the IFB from the Purchasing Office, the addendum will be emailed. Any Addenda so issued are to be considered a part of this IFB document.
3. State Finance Law Section 139-j and 139K (see Exhibit A), includes and imposes certain restrictions on communications between the Authority and Bidder during the procurement process. A bidder is restricted from making contacts from the earliest notice of intent to solicit offers through final award and approval of the contract by the Authority ("restricted period") to other than designated staff unless it is a contact that is included among certain statutory exceptions set forth in State Finance Law Section 139-j(3)(a). Designated staff, as of the date hereof, is the Purchasing Agent, Bobbi Matthews. Authority employees are also required to obtain certain information when contacted during the restricted period and make a determination of the responsibility of the offerer/bidder is debarred from obtaining governmental procurement contracts. Further information about these requirements can be found by examining the New York State Procurement Lobbying Law.

B. Addenda

Any interpretation, corrections and changes to this IFB and requirements or extensions to the acknowledgment/submittal date will be made by Addenda. Sole issuing authority of addenda shall be vested in the Purchasing Office as entrusted by the Authority. Addenda will be posted on Bid Net Direct. Bidders shall acknowledge receipt of all Addenda.

C. Bid Due Date

Qualified bidders are required to submit one (1) Master Copy of their bid and four (4) copies in its entirety in the manner specified in the IFB. The bid documents must be signed by a person authorized to legally bind the entity submitting the bid, enclosed in a sealed envelope or package marked **Contract #E-1194 Airport Carrier Vehicle with High Speed Snow Blower** and be received by mail or hand delivered to the Purchasing

Office no later than **11:00 AM (EST) on August 1, 2024**, at the address shown below. All bid packages received will be dated and time stamped with the official time by the Purchasing Office upon receipt. Any bid package received after this stipulated time will be returned unopened.

BIDS are to be sent or delivered to:

**Albany County Airport Authority
Purchasing Office
22 Jetway Drive
Albany, New York 12211-1057**

D. Late Bids

Bids received in the Authority Purchasing Office after the submission deadline shall be returned unopened and will be considered void and unacceptable. The Authority is not responsible for lateness of mail, carrier, etc. and the date/time stamped in the Purchasing Office shall be the official time of receipt.

E. Altering Bids

Bids cannot be altered or amended after submission deadline. The signer of the bid, guaranteeing authenticity, must initial any interlineation, alteration or erasure made before opening time.

F. Withdrawal of Bid

A bid may not be withdrawn or canceled by the bidder without forfeiture of the Deposit, Bond or Letter of Credit (if applicable) following the date designated for the acknowledgment of bids and the Bidder so agrees upon submittal of their Bid.

G. Exclusion

No oral, telegraphic, telephonic or facsimile Bids will be considered.

H. No Submittal

Should the vendor not wish to submit at this time but wishes to remain on the list for future Bids, please submit a "NO SUBMITTAL" by the same time and at the same location as stated for acknowledgment. If response is not received in the form of a "BID" or "NO BID" for three (3) consecutive IFBs the vendor shall be removed from vehicle commodity list. If, however, you choose to "NO BID" this product and/or service and wish to remain on the commodity/service list for other commodities and/or services, please state the particular product and/or service under which you wish to be classified.

The Authority is always conscious and appreciative of the time and effort expended to submit a Bid. We would appreciate your indicating on your “NO SUBMITTAL” response any requirements of this Bid that may have influenced your decision for a “NO SUBMITTAL.”

Bidders desiring a copy of the submittal acknowledgment may request such by enclosing a self-addressed, stamped envelope with their Bid. BID ACKNOWLEDGMENTS WILL NOT BE GIVEN BY TELEPHONE. If you have any questions, please contact the Albany County Airport Purchasing Department at (518) 242-2213.

I. Vendor Protest Policy & Procedures

Vendors may obtain a copy of the Airport Authority’s Protest Policy & Procedures by requesting a copy of the policy from the Albany County Airport Authority Purchasing Office in writing by email to bmatthews@albanyairport.com.

SECTION V: IFB EVALUATION PROCESS

A. Evaluation Criteria

Bids received will be evaluated by the Airport Authority, and will be based, as a minimum, upon the following criteria;
pon the following criteria;

1. Lowest total bid cost and projected timetable for delivery of goods as described herein;
2. Completeness of the bid; and
3. Bidder's demonstrated capabilities and professional qualifications.

B. Evaluation of Bids

1. Each Bid submitted will be evaluated by a Review Panel designated by the Authority. All Bids will be evaluated, based on the evaluation and selection factors stated in this IFB.
2. During the IFB evaluation period all communication must be directed to the Authority's Purchasing Agent.
3. Each bid will be evaluated according to the following process to determine how well it meets the evaluation criteria outlined in this IFB.
 - a. The first step in the evaluation process will be to determine the degree to which the IFB conforms to the minimum criteria for consideration. Those vendors failing to meet minimum requirements, including completeness, format and content, may be rejected without further evaluation and the vendor will be so informed in writing.
 - b. All Bids not rejected will be evaluated according to the criteria listed in this section to determine finalists. Vendors not selected as finalists will be rejected from further evaluation and will be informed in writing.

- c. The equipment proposed will be evaluated to determine if it meets the minimum specifications included in this IFB. Any significant deviation or failure to meet such requirements can be cause for rejection of the Bid submitted.
- d. All remaining Bid packages shall be evaluated according to lowest responsible bid offered. This includes evaluation of exceptions, variances including "or equal" substitutions, additional options, warrant or warranties, and prompt payment discounts.
- e. The Authority will ensure that consistent review and analysis techniques are used to evaluate the materials submitted with the Bid; and it will then submit recommendations to the Authority regarding Bidder selection.
- f. A final recommendation will be given to the vendor whose Bid package, in the sole discretion of the Review Panel best meets the established criteria and the overall requirements desired by the Airport. If, for any reason, an award cannot be made to the first recommended vendor, final negotiation will take place with the next best-ranked vendor. The Authority Board will act upon the recommendations of the Panel for acceptance or rejection of the Panel's recommendation.

C. Disqualification of a Bidder & Rejection of a Bid

Any one or more of the following, among others, may be considered sufficient for the disqualification of a Bidder and the rejection of the bid.

1. Evidence of collusion among Bidders.
2. Failure to satisfy the requirements of the IFB.
3. Lack of responsibility as shown by past work, reference, or other factors.
4. Default or termination of other contracts or agreements.
5. Other causes, as the Authority deems appropriate at the Authority's sole and absolute discretion.

D. Rights to Accept or Reject

It is understood that the Authority reserves the right to accept or reject any and all Bids for any/or all products covered in this IFB and to waive irregularities or technical deficiencies and to negotiate with the selected respondents any desired changes in the Bid

package which, in the judgment of the Authority, best meet the requirements of the Authority.

E. Final Selection

The final selection will be made based on the Authority's determination of the respondent's overall ability to provide the equipment meeting the intent of the specifications, which most nearly satisfies the overall operating requirements of the Airport.

F. Additional Information

All firms are hereby placed on notice that the Authority and all prospective bidders are subject to the terms set forth in New York State Finance Law, Chapter 56 of the Consolidated Laws, Article IX – Contracts, Section 139-j – “Restrictions on contact during the procurement process” and Section 139-k – “Disclosure of contacts and responsibility of officers.” (See Exhibit A)

SECTION VI: BID SUBMISSION REQUIREMENTS

A. Minimum Qualifications

The Authority requires that all Bidders possess certain references to ensure high quality equipment meeting the required specifications and standards for delivery to the Airport. Bidders shall meet the following minimum requirements for consideration:

1. Bidders shall be able to successfully provide equipment meeting the specifications requested for the Albany International Airport.
2. Bidder must be able to meet the delivery date of August 1, 2025.
3. Bidders must be otherwise qualified and eligible to receive an award.

Vendors not meeting these minimum requirements may be rejected and may be excluded from further consideration in the selection process.

B. Important Notice

The New York State Freedom of Information Law (FOIL), as set forth in Public Officers Law, Article 6, mandates public access to certain government records. Generally, bids submitted in response to this Request for Bid may constitute government records subject to FOIL. Bids may contain, among other things, certain technical, financial, or other data and information that constitute trade secrets, if publicly disclosed, could cause substantial injury to the commercial enterprise's competitive position. To protect this information from disclosure under FOIL, Bidders should specifically identify the pages of the bid that contain such information by properly marking the top of the applicable pages as "CONFIDENTIAL" and inserting the following statement in the front of its bid submittal:

The information or data on pages _____ of this bid submittal, identified on the top thereof as "CONFIDENTIAL", contain financial, technical or other information that constitute trade secrets or such, if publicly disclosed, would result in substantial injury to our competitive position. We request that the Authority use such information only for the evaluation of this Bid but we understand that the Authority must comply with the provisions of the New York State Freedom Of Information Law (FOIL) and that public disclosure of the information contained in this bid whether or not marked as "CONFIDENTIAL", and to make no claim for any damages as a result of any such disclosure by the Authority pursuant to FOIL.

In the event the Authority receives a FOIL request for disclosure of information marked as "CONFIDENTIAL", the bidder shall be notified of the request and

may expeditiously submit a detailed statement and explanation indicating the reasons the Bidder has for believing that the information requested is exempt from disclosure under the law. This detailed statement and explanation shall be used by the Authority in making its determination as to whether disclosure is required under the law.

C. Submittal

Bidders are encouraged to submit sufficient information that is pertinent and would assist the Authority in making its decision in the award of equipment. **In order to aid in the evaluation of bids, issues shall be referenced in the submittal by section and item order and properly marked for evaluation referencing.**

D. Documentation

Bidders shall provide with the Bid submittal, all documentation required by this INVITATION FOR BIDS (IFB). Failure to provide this information may result in rejection of the bid.

Provide as much written text as considered necessary to effectively describe the proposed equipment, options and your firm's qualifications, etc.

E. Bid Deposit

A bid deposit is not required for this RFB.

F. Submittal Requirements

The Bidder's submittal shall consist of the following documents in the sequence shown below. A set of tabs to identify each part of the bid should be inserted to facilitate quick reference. **Bidders shall submit five (5) bound sets including one (1) Master and four (4) identical copies.**

1. **Cover Letter:** (Limit 1 page) Cover letter to identify Bidder, the Bidder's business organization, and the personnel the Authority should contact concerning the Bid including names, mailing address, telephone numbers and e-mail contact information .
2. **Executive Summary:** (Limit 1 page) Executive Summary of important data about the Bidder, including a statement of minimum qualifications that should be highlighted for the review by the Authority.
3. **Experience:** (Limit 3 Pages) Set forth the specific experience the Bidder has had with providing similar equipment. Identify locations and for each location

describe the type of equipment provided, and the name, mailing address, telephone number and e-mail contact information for individual references.

4. **Documents Required To Be Submitted With Bid:** In addition to the information set forth above, Bidders are required to provide all documents listed in this IFB Exhibit D with their Bid submittal. Failure to provide this information may result in rejection of the Bid.
5. **FACSIMILE TRANSMITTALS SHALL NOT BE ACCEPTED.**
6. **ALL BIDS MUST BE RECEIVED IN THE AUTHORITY PURCHASING OFFICE BEFORE ACKNOWLEDGMENT DATE AND TIME.**
7. **Signatures:** Bids must be signed in ink by an authorized officer, all partners, or all joint venture members of the firm.
8. **Collusion:** The Authority will reject a vendor's Bid if more than one Bid is received from that vendor or if it is found that collusion exists between or amongst Bidders.
9. **Incomplete Bids will be rejected.**

Exhibit "A"
New York State Finance Law
Sections 139-j and 139-k

SECTION 139-J

Restrictions on contacts during the procurement process
State Finance (STF) CHAPTER 56, ARTICLE 9

* § 139-j. Restrictions on contacts during the procurement process. 1 or the purposes of this section, the following terms will have the following meanings unless specified otherwise.

a. "Governmental entity" shall mean: (1) any department, board, bureau, commission, division, office, council, committee or officer of the state, whether permanent or temporary; (2) each house of the state legislature; (3) the unified court system; (4) any public authority, public benefit corporation or commission created by or existing pursuant to the public authorities law; (5) any public authority or public benefit corporation, at least one of whose members is appointed by the governor or who serves as a member by virtue of holding a civil office of the state; (6) a municipal agency, as that term is defined in paragraph (ii) of subdivision (s) of section one-c of the legislative law; or (7) a subsidiary or affiliate of such a public authority.

b. "Article of procurement" shall mean a commodity, service, technology, public work, construction, revenue contract, the purchase, sale or lease of real property or an acquisition or granting of other interest in real property, that is the subject of a governmental procurement.

c. "Contacts" shall mean any oral, written or electronic communication with a governmental entity under circumstances where a reasonable person would infer that the communication was intended to influence the governmental entity's conduct or decision regarding the governmental procurement.

d. "Proposal" shall mean any bid, quotation, offer or response to a governmental entity's solicitation of submissions relating to a procurement.

e. "Governmental procurement" shall mean: (i) the public announcement, public notice, or public communication to any potential vendor of a determination of a need for a procurement, which shall include, but not be limited to, the public notification of the specifications, bid documents, request for proposals, or evaluation criteria for a procurement contract, (ii) solicitation for a procurement contract, (iii) evaluation of a procurement contract, (iv) award, approval, denial or disapproval of a procurement contract, or (v) approval or denial of an assignment, amendment (other than amendments that are authorized and payable under the terms of the procurement contract as it was finally awarded or approved by the comptroller, as applicable), renewal or

extension of a procurement contract, or any other material change in the procurement contract resulting in a financial benefit to the offerer.

f. "Restricted period" shall mean the period of time commencing with the earliest posting, on a governmental entity's website, in a newspaper of general circulation, or in the procurement opportunities newsletter in accordance with article four-C of the economic development law of written notice, advertisement or solicitation of a request for proposal, invitation for bids, or solicitation of proposals, or any other method provided for by law or regulation for soliciting a response from offerers intending to result in a procurement contract with a governmental entity and ending with the final contract award and approval by the governmental entity and, where applicable, the state comptroller.

g. "Procurement contract" shall mean any contract or other agreement, including an amendment, extension, renewal or change order to an existing contract (other than amendments, extensions, renewals, or change orders that are authorized and payable under the terms of the contract as it was finally awarded or approved by the comptroller, as applicable), for an article of procurement involving an estimated annualized expenditure in excess of fifteen thousand dollars. Grants, article eleven-B state finance law contracts, program contracts between not-for-profit organizations, as defined in article eleven-B of this chapter, and the unified court system, intergovernmental agreements, railroad and utility force accounts, utility relocation project agreements or orders, contracts governing organ transplants, contracts allowing for state participation in trade shows, and eminent domain transactions shall not be deemed procurement contracts.

h. "Offerer" shall mean the individual or entity, or any employee, agent or consultant or person acting on behalf of such individual or entity, that contacts a governmental entity about a governmental procurement during the restricted period of such governmental procurement whether or not the caller has a financial interest in the outcome of the procurement; provided, however, that a governmental agency or its employees that communicates with the procuring agency regarding a governmental procurement in the exercise of its oversight duties shall not be considered an offerer.

i. "Revenue contract" shall mean any written agreement between a governmental entity, as that term is defined in subparagraphs one, four, five, six or seven of paragraph a of this subdivision, and an offerer whereby the governmental entity gives or grants a concession or a franchise.

j. "Unified court system" shall, for the purposes of this section only, mean the unified court system of the state of New York, or the office of court administration, where appropriate, other than town and village justice courts in jurisdictions with a population under fifty thousand, when it acts solely in an administrative capacity to engage in governmental procurements and shall not include the unified court system or any court of the state judiciary when it acts to hear and decide cases of original or appellate jurisdiction or otherwise acts in its judicial, as opposed to administrative, capacity.

2. Every governmental entity that undertakes a governmental procurement shall:

a. at the same time that a restricted period is imposed, designate, with regard to each governmental procurement, a person or persons who are knowledgeable about the procurement and who may be contacted by offerers relative to the governmental procurement;

b. make any determinations on any governmental procurement: (1) in a manner consistent with the principles provided for under subdivision two of section one hundred sixty-three of this chapter, or, if the governmental entity is a public benefit corporation, as that term is defined in section sixty-six of the general construction law, and the majority of the members consist of persons either appointed by the governor or who serve as members by virtue of holding a civil office of the state, the procurement guidelines adopted pursuant to section twenty-eight hundred seventy-nine of the public authorities law, and (2) free from any conduct that would be prohibited by subdivision five of section seventy-three or section seventy-four of the public officers law, or of other applicable ethics code provisions that are equivalent to subdivision five of section seventy-three or section seventy-four of the public officers law where the public officials that are involved in the governmental procurement are not subject to subdivision five of section seventy-three or section seventy-four of the public officers law;

3. Each offerer that contacts a governmental entity about a governmental procurement shall only make permissible contacts with respect to the governmental procurement, which shall mean that the offerer:

a. shall contact only the person or persons who may be contacted by offerers as designated by the governmental entity pursuant to paragraph a of subdivision two of this section relative to the governmental procurement, except that the following contacts are exempted from the provisions of this paragraph and do not need to be directed to a designated contact pursuant to section one hundred thirty-nine-k of this article:

(1) the submission of written proposals in response to a request for proposals, invitation for bids or any other method for soliciting a response from offerers intending to result in a procurement contract;

(2) the submission of written questions by a method set forth in a request for proposals, or invitation for bids, or any other method for soliciting a response from offerers intending to result in a procurement contract, when all written questions and responses are to be disseminated to all offerers who have expressed an interest in the request for proposals, or invitation for bids, or any other method for soliciting a response from offerers intending to result in a procurement contract;

(3) participation in a demonstration, conference or other means for exchange of information in a setting open to all potential bidders provided for in a request for proposals, invitation for bids, or any other method for soliciting a response from offerers intending to result in a procurement contract;

(4) complaints by an offerer regarding the failure of the person or persons designated by the procuring governmental entity pursuant to this section to respond in a timely manner to authorized offerer contacts made in writing to the office of general counsel of the procuring governmental entity, provided that any such written complaints shall become a part of the procurement record;

(5) offerers who have been tentatively awarded a contract and are engaged in communications with a governmental entity solely for the purpose of negotiating the terms of the procurement contract after being notified of tentative award;

(6) contacts between designated governmental entity staff of the procuring governmental entity and an offerer to request the review of a procurement contract award;

(7) (a) contacts by offerers in protests, appeals or other review proceedings (including the apparent successful bidder or proposer and his or her representatives) before the governmental entity conducting the procurement seeking a final administrative determination, or in a subsequent judicial proceeding; or

(b) complaints of alleged improper conduct in a governmental procurement to the attorney general, inspector general, district attorney, or court of competent jurisdiction; or

(c) protests, appeals or complaints to the state comptroller's office during the process of contract approval, where the state comptroller's approval is required, provided that the state comptroller shall make a record of such communications and any response thereto which shall be entered into the procurement record pursuant to section one hundred sixty-three of this chapter; or

(d) complaints of alleged improper conduct in a governmental procurement conducted by a municipal agency or local legislative body to the state comptroller's office;

(8) communications between offerers and governmental entities that solely address the determination of responsibility by a governmental entity of an offerer;

(9) Any communications relating to a governmental procurement made under section one hundred sixty-two of the state finance law undertaken by (i) the non-profit-making agencies appointed pursuant to paragraph e of subdivision six of section one hundred sixty-two of the state finance law by the commissioner of the office of children and family services, the commission for the blind, or the commissioner of education, and (ii) the qualified charitable non-profit-making agencies for the blind, and qualified charitable non-profit-making agencies for other severely disabled persons as identified in subdivision two of section one hundred sixty-two of this chapter; provided, however, that any communications which attempt to influence the issuance or terms of the specifications that serve as the basis for bid documents, requests for proposals, invitations for bids, or solicitations of proposals, or any other method for soliciting a response from offerers intending to result in a procurement contract with a state agency, the state

legislature, the unified court system, a municipal agency or local legislative body shall not be exempt from the provisions of this paragraph;

(10) Complaints by minority-owned business enterprises or women-owned business enterprises, certified as such by the division of minority and women's business development, to the minority and women-owned business enterprise statewide advocate concerning the procuring governmental entity's failure to comply with the requirements of section three hundred fifteen of the executive law;

(11) Communications between the minority and women-owned business enterprise statewide advocate and the procuring governmental entity in furtherance of an investigation of the minority and women-owned business enterprise statewide advocate pursuant to section three hundred twelve-a of the executive law.

provided, however, that nothing in this subdivision shall be construed as recognizing or creating any new rights, duties or responsibilities or abrogating any existing rights, duties or responsibilities of any governmental entity as it pertains to implementation and enforcement of article eleven of this chapter or any other provision of law dealing with the governmental procurement process, and that nothing in this subdivision shall be interpreted to limit the authority of a governmental entity involved in a government procurement by exercise of an oversight function from providing information to offerers regarding the status of the review, oversight, or approval of a governmental procurement that has been submitted to or is under review by that governmental entity.

b. shall not attempt to influence the governmental procurement in a manner that would result in a violation or an attempted violation of subdivision five of section seventy-three or section seventy-four of the public officers law, or of other applicable ethics code provisions that are equivalent to subdivision five of section seventy-three or section seventy-four of the public officers law where the public officials that are involved in the governmental procurement are not subject to subdivision five of section seventy-three or section seventy-four of the public officers law;

4. Violations of paragraph a of subdivision three of this section shall include any contacts during the restricted period of a governmental procurement between the offerer and any member, officer or employee of any governmental entity other than the entity conducting the governmental procurement; provided, however, that nothing in this section shall be deemed to prohibit an offerer from communicating with a member of the state legislature or legislative staff about a governmental procurement being conducted by a governmental entity other than the state legislature, or a member of the state legislature or legislative staff contacting a governmental entity about a governmental procurement being conducted by a governmental entity other than the state legislature, provided that the member of the state legislature or legislative staff is acting in his or her official capacity.

5. Governmental entity staff may consult the model guidelines that may be established by the advisory council on procurement lobbying pursuant to section one-t of the legislative law in implementing this section.

6. a. Every governmental entity shall incorporate a summary of the policy and prohibitions regarding permissible contacts during a governmental procurement pursuant to subdivision three of this section, and copies of rules and regulations and applicable governmental entity guidelines and procedures regarding permissible contacts during a governmental procurement pursuant to subdivision three of this section into their solicitation of proposals or bid documents or specifications for all procurement contracts.

b. Every governmental entity shall seek written affirmations from all offerers as to the offerer's understanding of and agreement to comply with the governmental entity's procedures relating to permissible contacts during a governmental procurement pursuant to subdivision three of this section. Such a written affirmation by an offerer shall be deemed to apply to any amendments to a procurement submitted by the governmental entity after an initial affirmation is received with an initial bid.

7. Notwithstanding any law to the contrary, prior to conducting an award of a procurement contract, a governmental entity conducting a governmental procurement shall make a final determination of responsibility of the proposed awardee in accordance with paragraph f of subdivision nine of section one hundred sixty-three of this chapter, or, if the governmental entity is a public benefit corporation, as that term is defined in section sixty-six of the general construction law, and the majority of the members consist of persons either appointed by the governor or who serve as members by virtue of holding a civil office of the state, according to the procurement guidelines adopted pursuant to subparagraph (iii) of paragraph (b) of subdivision three of section twenty-eight hundred seventy-nine of the public authorities law; provided, however, that nothing in this subdivision shall be construed as abrogating or diminishing any existing rights, duties or responsibilities of any governmental entity as it pertains to determinations of responsibility.

8. Any member, officer or employee of a governmental entity who becomes aware that an offerer has violated the provisions of subdivision three of this section with regard to permissible contacts during any governmental procurement shall immediately notify the ethics officer, inspector general, if any, or other official of the procuring governmental entity responsible for reviewing or investigating such matters. If an offerer violates the provisions of subdivision three of this section with regard to permissible contacts at a governmental entity other than the governmental entity conducting the governmental procurement, the member, officer or employee who becomes aware of the violation shall notify the ethics officer, inspector general, if any, or other official of the governmental entity responsible for reviewing or investigating such matters where that member, officer or employee works, who shall in turn notify the ethics officer, inspector general, if any, or other official of the procuring governmental entity responsible for reviewing or investigating such matters at the procuring governmental entity.

9. Every governmental entity shall establish a process for review by its ethics officer, inspector general, if any, or other official responsible for reviewing or investigating any allegations of violations of the provisions of subdivision three of this section with regard to permissible contacts on governmental procurements, and for the imposition of sanctions if such violations have been found to exist.

10. a. Upon notification of any allegation of a violation of the provisions of subdivision three of this section with regard to permissible contacts on governmental procurements, the governmental entity's ethics officer, inspector general, if any, or other official of the procuring governmental entity responsible for reviewing or investigating such matters shall immediately investigate such allegation and, if sufficient cause exists to believe that such allegation is true, shall give the offerer reasonable notice that an investigation is ongoing and an opportunity to be heard in response to the allegation.

b. A finding that an offerer has knowingly and willfully violated the provisions of subdivision three of this section shall result in a determination of non-responsibility for such offerer, and such offerer and its subsidiaries, and any related or successor entity with substantially similar function, management, board of directors, officers and shareholders (hereinafter, for the purposes of this paragraph "offerer"), shall not be awarded the procurement contract, unless the governmental entity finds that the award of the procurement contract to the offerer is necessary to protect public property or public health or safety, and that the offerer is the only source capable of supplying the required article of procurement within the necessary timeframe, provided, that the governmental entity shall include in the procurement record a statement describing the basis for such a finding. Any subsequent determination of non-responsibility due to violation of this section within four years of a determination of non-responsibility due to a violation of this section shall result in the offerer being rendered ineligible to submit a proposal on or be awarded any procurement contract for a period of four years from the date of the second final determination. Every governmental entity shall ensure that its solicitations of proposals for procurement contracts require offerers to disclose findings of non-responsibility due to violations of the provisions of subdivision three of this section within the previous four years by any governmental entity. The failure of offerers to timely disclose accurate and complete information or otherwise cooperate with the governmental entity in administering this provision shall be considered by the governmental entity in its determination of responsibility; provided, further, that the governmental entity shall not award a contract to an offerer who fails to timely disclose accurate and complete information or otherwise cooperate with the governmental entity in administering this provision unless the governmental entity finds that the award of the procurement contract to the offerer is necessary to protect public property or public health or safety, and that the offerer is the only source capable of supplying the required article of procurement within the necessary timeframe, provided, that the governmental entity shall include in the procurement record a statement describing the basis for such a finding. Upon a determination of non-responsibility or debarment due to a violation of this section, the governmental entity shall notify the office of general services, which shall keep a list of all offerers who have been determined to be nonresponsible bidders or debarred due to violations of

this section; the office of general services shall make publicly available such list and shall publish such list on its web site.

c. If a violation of the provisions of subdivision three of this section is found to have knowingly and willfully occurred, then the ethics officer or inspector general, if any, or other official of the procuring governmental entity responsible for reviewing or investigating such matters shall report instances of employee violation of the guidelines and procedures regarding implementation of subdivision two of this section to the governmental entity's head.

11. Nothing in this section shall be deemed to prevent: (a) contacts by offerers in protests, appeals or other review proceedings (including the apparent successful bidder or proposer and his or her representatives) before the governmental entity conducting the procurement seeking a final administrative determination, or in a subsequent judicial proceeding; or

(b) complaints of alleged improper conduct in a governmental procurement to the attorney general, inspector general, district attorney, or court of competent jurisdiction; or

(c) written protests, appeals or complaints to the state comptroller's office during the process of contract approval, where the state comptroller's approval is required by law, and where such communications and any responses thereto are made in writing and shall be entered in the procurement record pursuant to section one hundred sixty-three of this chapter; or

(d) complaints of alleged improper conduct in a governmental procurement conducted by a municipal agency or local legislative body to the state comptroller's office; provided, however, that nothing in this subdivision shall be construed as recognizing or creating any new rights, duties or responsibilities or abrogating any existing rights, duties or responsibilities of any governmental entity as it pertains to implementation and enforcement of article eleven of this chapter or any other provision of law dealing with the governmental procurement process.

* NB Repealed July 31, 2026

SECTION 139-K

Disclosure of contacts and responsibility of offerers

State Finance (STF) CHAPTER 56, ARTICLE 9

* § 139-k. Disclosure of contacts and responsibility of offerers. 1. For purposes of this section, the following terms will have the following meanings unless specified otherwise.

a. "Governmental entity" shall mean: (1) any department, board, bureau, commission, division, office, council, committee or officer of the state, whether permanent or temporary; (2) each house of the state legislature; (3) the unified court system; (4) any public authority, public benefit corporation or commission created by or existing pursuant to the public authorities law; (5) a public authority or public benefit corporation, at least one of whose members is appointed by the governor or who serves as a member by virtue of holding a civil office of the state; (6) municipal agency, as that term is defined in paragraph (ii) of subdivision (s) of section one-c of the legislative law; or (7) a subsidiary or affiliate of such a public authority.

b. "Article of procurement" shall mean a commodity, service, technology, public work, construction, revenue contract, the purchase, sale or lease of real property or an acquisition or granting of other interest in real property, that is the subject of a governmental procurement.

c. "Contacts" shall mean any oral, written or electronic communication with a governmental entity under circumstances where a reasonable person would infer that the communication was intended to influence the governmental entity's conduct or decision regarding the governmental procurement.

d. "Proposal" shall mean any bid, quotation, offer or response to a governmental entity's solicitation of submissions relating to a procurement.

e. "Governmental procurement" shall mean: (i) the public announcement, public notice, or public communication to any potential vendor of a determination of a need for a procurement, which shall include, but not be limited to, the public notification of the specifications, bid documents, request for proposals, or evaluation criteria for a procurement contract, (ii) solicitation for a procurement contract, (iii) evaluation of a procurement contract, (iv) award, approval, denial or disapproval of a procurement contract, or (v) approval or denial of an assignment, amendment (other than amendments that are authorized and payable under the terms of the procurement contract as it was finally awarded or approved by the comptroller, as applicable), renewal or extension of a procurement contract, or any other material change in the procurement contract resulting in a financial benefit to the offerer.

f. "Restricted period" shall mean the period of time commencing with the earliest posting, on a governmental entity's website, in a newspaper of general circulation, or in the procurement opportunities newsletter in accordance with article four-C of the economic development law of

written notice, advertisement or solicitation of a request for proposal, invitation for bids, or solicitation of proposals, or any other method provided for by law or regulation for soliciting a response from offerers intending to result in a procurement contract with a governmental entity and ending with the final contract award and approval by the governmental entity and, where applicable, the state comptroller.

g. "Procurement contract" shall mean any contract or other agreement, including an amendment, extension, renewal, or change order to an existing contract (other than amendments, extensions, renewals, or change orders that are authorized and payable under the terms of the contract as it was finally awarded or approved by the comptroller, as applicable), for an article of procurement involving an estimated annualized expenditure in excess of fifteen thousand dollars. Grants, article eleven-B state finance law contracts, program contracts between not-for-profit organizations, as defined in article eleven-B of this chapter, and the unified court system, intergovernmental agreements, railroad and utility force accounts, utility relocation project agreements or orders, contracts governing organ transplants, contracts allowing for state participation in a trade show, and eminent domain transactions shall not be deemed procurement contracts.

h. "Offerer" shall mean the individual or entity, or any employee, agent or consultant or person acting on behalf of such individual or entity, that contacts a governmental entity about a governmental procurement during the restricted period of such governmental procurement whether or not the caller has a financial interest in the outcome of the procurement; provided, however, that a governmental agency or its employees that communicates with the procuring agency regarding a governmental procurement in the exercise of its oversight duties shall not be considered an offerer.

i. "Revenue contract" shall mean any written agreement between a governmental entity, as that term is defined in subparagraphs one, four, five, six or seven of paragraph a of this subdivision, and an offerer whereby the governmental entity gives or grants a concession or a franchise.

j. "Unified court system" shall, for the purposes of this section only, mean the unified court system of the state of New York, or the office of court administration, where appropriate, other than town and village justice courts in jurisdictions with a population under fifty thousand, when it acts solely in an administrative capacity to engage in governmental procurements and shall not include the unified court system or any court of the state judiciary when it acts to hear and decide cases of original or appellate jurisdiction or otherwise acts in its judicial, as opposed to administrative, capacity.

2. Each governmental entity shall ensure that solicitation of proposals or bid documents or specifications, or contract documents, as applicable, for procurement contracts shall require offerers to disclose findings of non-responsibility made within the previous four years by any governmental entity where such prior finding of non-responsibility was due to: (a) a violation of section one hundred thirty-nine-j of this article, or (b) the intentional provision of false or incomplete information to a governmental entity.

3. The failure of an offerer to timely disclose accurate or complete information to a governmental entity pursuant to subdivision two of this section shall be considered by such governmental entity in its determination of the responsibility of such offerer. No procurement contract shall be awarded to any such offerer, its subsidiaries, and any related or successor entity with substantially similar function, management, board of directors, officers and shareholders (hereinafter, for the purposes of this subdivision, "offerer"), unless the governmental entity finds that the award of the procurement contract to the offerer is necessary to protect public property or public health or safety, and that the offerer is the only source capable of supplying the required article of procurement within the necessary timeframe, provided, that the governmental entity shall include in the procurement record a statement describing the basis for such a finding.

4. Upon any contact in the restricted period, the governmental entity shall obtain the name, address, telephone number, place of principal employment and occupation of the person or organization making the contact and inquire and record whether the person or organization making such contact was the offerer or was retained, employed or designated by or on behalf of the offerer to appear before or contact the governmental entity about the governmental procurement. All recorded contacts shall be included in the procurement record for the procurement contract.

5. Any procurement contract award subject to the provisions of this section and section one hundred thirty-nine-j of this article shall contain a certification by the offerer that all information provided to the procuring governmental entity with respect to this section is complete, true and accurate, and each such procurement contract shall contain a provision authorizing the governmental entity to terminate such contract in the event such certification is found to be intentionally false or intentionally incomplete. The governmental entity shall include in the procurement record a statement describing the basis for any action taken pursuant to such termination provision.

6. Any communications received by a governmental entity from members of the state legislature, or legislative staffs, when acting in their official capacity, shall not be considered to be a "contact" within the meaning of this section and shall not be recorded by a governmental entity pursuant to this section.

* NB Repealed July 31, 2026

EXHIBIT B: CONTRACTUAL TERMS AND CONDITIONS

(This EXHIBIT to be attached to Purchase Order)

A. Contract/Agreement

The successful bid, when properly accepted by the Authority, shall be subject to all the terms and conditions of the bid documents.

B. Purchase Order

The Albany County Airport Authority shall generate a purchase order(s) to the successful Bidder. The successful bidder shall not sell, assign, transfer or convey this purchase order, in whole or in part, without the prior written consent of the Authority.

C. Contract Administrator

The Authority will designate a contract administrator with designated responsibility to ensure compliance with all the Contractual Term and Conditions, including, but not limited to, the inspection and acceptance of the equipment provided. The Contract Administrator will serve as liaison between the Authority and the successful Bidder.

D. Performance Terms and Conditions:

1. The Purchase Order shall designate the place of delivery. There will be scheduled hours for the specific locations for equipment deliveries, which do not conflict with the Airport's peak traffic times. Deliveries should cause little or no interference with Airport Operations.
2. The condition of all equipment must be new and unused, unless otherwise specified, in first-class condition and of current manufacture.
3. Authority personnel will conduct a full visual and operating inspection before accepting the equipment. The Authority shall have the right to request any improvements necessary so the equipment meets the specifications set forth in the IFB and the Bidders response before accepting the equipment. Inspection and/or testing may be performed at the request of the Authority, with concurrence of the Bidder, by an agent so designated, without expense to the Airport.

If after inspection, problem areas that are not corrected immediately (within one (1) working day) of notification by the Authority, unless involving an emergency where work shall occur (within one (1) hour), and must be corrected using an outside source other than the successful Bidder, we shall deduct charges for such outside services from payment for failure to perform in keeping with the terms of this contract.

4. Successful bidder warrants that all equipment conform to the proposed specifications, drawings, descriptions listed in the bid invitation, if any, and the Bidder response, and/or all warranties as stated in the Uniform Commercial Code and be free from all defects in material, workmanship and title. The successful bidder shall not limit or exclude any implied warranties and any attempt to do so may render the purchase order null and void at the option of, and at no expense, to the Airport.

5. Title and Risk of Loss shall not pass to the Authority until the Authority actually receives and takes possession of the equipment at the place of delivery.

E. Payments:

1. The Authority will make payment only after receipt, inspection and acceptance of the equipment ordered.
2. Vendor invoices shall show the purchase order number and shall be accompanied by a signed Authority Claim Forms. Invoices and Claim Forms shall be mailed to: Albany County Airport Authority, 737 Albany Shaker Road, Albany, New York, 12211-1057. ATTN.: Accounts Payable.
3. The vendors invoice shall include and properly state any prompt payment discounts available.
4. The Authority shall not pay any freight and/or delivery charges not specifically authorized and included on the purchase order.
5. The Albany County Airport Authority is exempt from the State Sales Tax.
6. The Authority requires the vendor and the vendor agrees to pay suppliers/ subcontractors within ten (10) days after the vendor receives payment from the Authority.
7. If during the term of the Agreement/Contract, the successful Bidder's pricing to other customers under the same terms and conditions for equipment awarded herein are reduced below the contracted price, it is understood and agreed that the benefits of that reduction shall be extended to the Authority.

F. Other Terms and Conditions:

1. Conflict Of Interest

No public official from the State of New York, County of Albany, or any local governmental unit located within the County of Albany shall have interest in the Agreement.

2. Venue

The Bidder and the Authority explicitly agrees that this IFB will be governed and construed according to the laws of the State of New York and the parties further agree that the Supreme Court, State of New York, County of Albany, the United States District Court, Northern District of New York shall be the forum for any actions brought under this IFB.

3. Silence of Requirements

The apparent silence of these Terms and Conditions as to any detail or to the apparent omission from it of the description concerning any point, shall be regarded as meaning that only the best business practices are to prevail. All interpretations of these requirements shall be made based on this statement.

4. Advertising

The successful Bidder shall not advertise or publish, without the Authority's prior written approval, the fact that the Authority has awarded a purchase order, except to the extent necessary to comply with proper requests for information from an authorized representative of the Federal, state or local government.

5. **Interference**

There shall be no interference with Albany Airport operations in the performance or delivery of the equipment ordered.

6. **Termination Rights By The Authority**

The Authority may terminate the contract for cause upon thirty (30) days written notice, should the successful Bidder be in default of any of the Terms and Conditions contained in this Exhibit. In such instances, the Authority is not required to purchase the Bidder's equipment, if any, and the bidder may be required to remove all equipment at its own expense in a timely manner.

7. **Representations**

No information derived from inspection of Airport records or reports of investigation concerning the Agreement will in any way relieve the successful Bidder from its responsibility or from properly performing its obligations under the purchase order. The Airport may have provided information as a convenience to the Bidder and did so without any warranty whatsoever by the Authority. The successful Bidder shall make its own conclusions and interpretations from the data supplied by the Authority and from information available from other sources.

8. **Cumulative Rights**

The rights and remedies provided by the Purchase Order are cumulative and the use of one right or remedy by a party shall not preclude or waiver the right to use any or all of the remedies.

9. **Indemnification**

The successful Bidder shall indemnify and save Albany County Airport Authority and the County of Albany harmless from and against all claims, demands, losses, costs, damages, suits, actions and proceedings by whomsoever made, brought or prosecuted and in any manner based upon arising out or, related to, occasioned by or attributable to the infringement or contribution to the infringement of any intellectual or industrial property right by the articles, methods, processes or act employed by, or plans, drawings, specifications another written data provided by, the successful bidder or its employees in concern with providing services hereunder (including, without limitations, legal expenses on a solicitor and client basis).

The successful Bidder shall have the right, in order to avoid such claims demands, losses, costs, damages, suits, action or proceedings, at its expense, to substitute, non infringing equipment, materials and processes, or to modify such infringing equipment, so they become non infringing equipment. The successful Bidder may wish to obtain the necessary licenses to use the infringing equipment, material and processes, if such substituted or modified equipment, materials and processes shall meet all the requirements and be subject to all the provisions of the Purchase Order.

The provisions of this Section shall survive the expiration or sooner termination of this Purchase Order.

10. Default

If the successful Bidder is in default, the Authority may, in its discretion, do all things necessary to effect compliance with the laws, regulation, by laws, directives, rules and conventions referred to therein, and the successful Bidder shall, on demand by the Authority, reimburse the Authority for all costs incurred by the Authority for that purpose.

11. Patents/Copyrights

The successful Bidder agrees to protect the Authority from claims involving infringements of patents and/or copyrights. By submission of this Bid and as part of the awarded contract for sale, the Bidder agrees to ascertain whether equipment manufactured to meet the specifications will cause the rightful claim of any third person by way of infringement or the like. The Authority makes no warranty that the production of equipment meeting the specifications will not cause such a claim, and in no event shall the Authority be liable to bidder for indemnification should the Bidder be sued on the grounds of infringement or the life. If the Bidder is of the opinion that an infringement or the like will result, the Bidder will notify the Authority to this effect in writing within two (2) weeks after the award of the Purchase Order. If the Authority does not receive notice and is subsequently held liable for the infringement or the like, Bidder will save the Authority harmless. If the Bidder in good faith ascertains that the performance of series according to the specifications will result in infringement or the like, the Purchase Order shall be null and void.

12. Remedies

The successful Bidder and the Authority agree that both parties have all rights, duties and remedies available as stated in the Uniform Commercial Code.

13. Ethics

The Bidder shall not accept or offer gifts or anything of value, nor enter any business arrangement with any employee, official or agent of the Authority. Any contact by a Bidder, unless specifically authorized, with Authority members, the Chief Executive Officer, or other Authority or Airport staff, other than with the Purchasing Office, shall be grounds for disqualification.

14. Compliance

All equipment must comply with all Federal, state, county and local laws concerning this type of equipment and the fulfillment of all ADA (American with Disabilities Act) requirements.

15. Drug/Smoke Free

Albany Airport maintains a drug and smoke free work place. Use, possession or under the influence of drugs and / or alcohol or smoking while in performance of the services is strictly prohibited.

16. Non-Discrimination Requirements

In accordance with Article 5 of the Executive Law (also known as the Human Rights Law) and all other State and Federal statutory and constitutional, non-discrimination provisions, the Bidder agrees that neither it, nor its subcontractors, shall be reason of race, creed, color, national origin, age, sex or disability: (a) discriminate in hiring against any person who is qualified and available to perform the work; or (b) discriminate against or intimidate any employee hired for the performance of work under the Agreement.

17 Warranty

The Successful Bidder shall warrant that the equipment offered shall conform to the specifications, drawings, descriptions listed in the IFB, the proposal submitted by Bidder, and/or all warranties as stated in the Uniform Commercial Code and be free from all defects in material, workmanship and title. The successful Bidder will not limit or exclude any implied warranties and any attempt to do so may render the awarded Purchase Order voidable at the option of the Authority. In case of conflict between specifications, drawings and descriptions, the specifications shall govern.

18. Safety Warranty

Successful Bidder warrants that the equipment provided shall conform to the standards declared by the U.S. Department of Labor under the Occupation Safety and Health Act of 1970, as amended. In the event the equipment does not conform to OSHA standards, the Authority may require the services conform at no additional expense to the Airport. In the event the successful Bidder fails to make the appropriate correction within a reasonable time, any corrections made by the Authority shall be at the successful Bidder's expense.

EXHIBIT C: MINIMUM TECHNICAL SPECIFICATIONS

**Model Year 2024 or Newer Airport Carrier Vehicle With
High Speed Snow Blower**

The following publications form a part of this document to the extent specified herein. The latest issue of FAA Advisory Circular AC 150/5220-20A and SAE Aerospace Recommended Practice (ARP) publications shall apply. The applicable issue of other publications shall be the issue in effect on the date of the purchase order. In the event of a conflict between the text of this document and references cited herein, the text of this document takes precedence. Nothing in this document, however, supersedes applicable laws and regulations unless a specific exemption has been obtained.

Where minimum specifications are attributed to a reference document, they may include supplemental requirements established in this IFB. This procurement is open to all bidders and alternative designs will be considered. We understand that different manufactures will have different designs which may deviate from the desired specifications. Deviations from the specifications will be accepted if the proposed equipment meets the requirements for the high speed snow blowing capacity required by this IFB. Please provide a list your exceptions as part of your submittal package as described within this IFB.

- SAE ARP5539–Rotary Plow with Carrier Vehicle
 - Specification can be purchased from: <http://standards.sae.org/arp5539/>
- FAA AC 150/5220-20A - [Airport Snow and Ice Control Equipment](#)
 - Specification can be downloaded from:
http://www.faa.gov/documentLibrary/media/Advisory_Circular/150_5220_20a.pdf
- FAA AC 150/5210-5D - Painting, Marking, and Lighting of Vehicles Used on an Airport
 - Specification can be downloaded from:
http://www.faa.gov/documentLibrary/media/Advisory_Circular/150_5210_5d.pdf
- AC 150/5200-30D Airport Winter Safety and Operations
- Title 49, Chapter III, Subchapter B-Federal Motor Carrier Safety Regulations (Title 49)

The unit shall be designed and manufactured in the United States and meet buy American requirements. All parts of the vehicle shall be engineered and classified as heavy duty, and shall be of the size, material, and strength to sustain the maximum loads and sever operating conditions while resulting in minimum wear and failure.

CARRIER VEHICLE. Carrier vehicle shall comply with SAE ARP5539 specifications, and shall meet the performance requirements identified in FAA AC 150/5220-20A. See technical specifications listed below for additional requirements.

- The unit shall be adequate size, type and configuration to provide support and transport capability of the snow blower.
- The unit must be capable of operating and cold soaked starting at temperatures as low as -40° F and as high as 110° F.
- The unit will be used for snow removal from runways, taxiways, ramps, roadways, parking lots.
- The unit must be certified for both aeronautical and on public roads. Axle and vehicle weights must comply with state and local highway load limits (combined load).
- The unit will be driven to the off-site repair facility when needed.

AVIATION MOBILE AIR BAND RADIO. Radio shall be ICOM IC-A120 VHF air band transceiver or approved equal. Each transceiver shall be equipped with its own microphone, antenna and remote speaker. VHF radios used to communicate with air traffic control facilities shall satisfy the criteria set forth in section 3 of Radio Technical Commission for Aeronautics document DO-186, "Minimum Performance Standards for Airborne Radio Communications Equipment Operating Within the Radio Frequency Range 117.975 to 137.000 MHz.," dated January 20, 1984. This document may be examined at any Federal Aviation Administration Regional Office or purchased from: RTCA Secretariat, One McPherson Square, 1425 K Street, NW, Suite 500, Washington, DC 20005. Transceivers using other frequencies shall meet applicable standards of the Federal Communications Commission. The radio shall be mounted in a manner to be easily visible and operable by vehicle operator. The frequency used by the airport is 121.7 MHz.

AIRPORT OPERATIONS MOBILE RADIO. Radio shall be TBD at a later date. Each transceiver shall be equipped with its own microphone, antenna and remote speaker, and shall be installed and configured to ensure that the county mobile radio frequencies do not interfere with Aviation radio frequencies. The radio shall be mounted in a manner to be easily visible and operable by vehicle operator.

PRE-BUILD MEETING. A pre-building meeting shall be required with the Albany County Airport Authority, truck dealer and equipment suppliers prior to truck assembly.

FINAL INSPECTION MEETING. The Dealer and or Manufacturer shall host a final inspection meeting with members of the Albany International Airport Vehicle Maintenance Department at the Manufacturer's location upon completion of the Equipment and prior to delivery. The purpose of this meeting is to inspect and approve all construction details. The transportation costs of this meeting shall be included in the Manufacturer's proposal cost.

DELIVERY METHOD. The equipment shall be delivered to the Albany International Airport, 130 Sicker Road, Latham NY 12110 no later than 365 days from receipt of order.

In accordance with AC 150/5220-20A, Appendix 1, Part A, the following Airport Operator Checklist shall be part of these specifications. Part A tailors the carrier vehicle to the specific requirements of this purchaser and Part B defines the specification to meet these requirements.

FAA AC 150/5220-20A
Appendix 1. Specification for Carrier Vehicle
Part A - Airport Operator Checklist

A1-1. Anticipated uses and/or features of the vehicle: The snow blower shall be used to move snow during large and small snow events at the airport. The carrier vehicle and snow blower shall be heavy duty to withstand the extreme winter conditions found in the airport environment. This unit is primarily used in large open area snowplowing operations that require a high-volume and high-speed snow discharge.

A1-2. Performance requirements.

- a. Required Working speed: from 0 to 45 miles per hour minimum
- b. Minimum speed: 0 miles per hour
- c. Turning radius: 80-deg. arc (measured to centerline of outside tire)

A1-3. Engine/transmission:

- a. The transmission shall be a six speed electronic automatic shifting type – Allison 4000 rugged duty series or equivalent. Provide appropriate sized torque converter and oil level sensor.
- b. The carrier vehicle engine shall be positioned behind the cab. The engine shall be proven to be compliant with Tier 4 Final (EU Stage IV) emissions levels per the EPA.

A1-4. Transfer case – Standard transfer case as recommended by the manufacturer.

A1-5. Axle capacities: Front Drive Axle: 27,000 lbs GVW; Rear Axle: 23,000 lbs GVW
minimum (at hubs); Total: 50,000 lbs

A1-6. Minimum Fuel capacity: Dual 125 gallon, single side fuel fill.

A1-7. Auxiliary equipment. See Appendix 2

FAA AC 150/5220-20A
Appendix 1. Specification for Carrier Vehicle
Part B – Specification for Carrier Vehicle

A1-8. Materials and components. See referenced SAE ARP5943 equipment specification.

A1-9. Delivery.

- a. Preparation for delivery.

- (1) Shipment. The vendor is responsible for the safe and timely delivery of the vehicle and its accessories, spare parts, and tools to the Albany International Airport, 130 Sicker Road, Latham, NY 12110.
- (2) Marking. Paint & Markings
 - a. Paint color shall be yellow, code 4421.
 - b. Shall be in full conformance with AC 150/5210-5D.
 - c. Shall have "Albany International Airport" on both doors. The logo design spec will be provided by the airport.
 - d. Shall have numbering on the cab in accordance with AC 150/5210-5D, numbering to be determined by the Airport Authority at time of assembly.
- b. Instruction and training. The manufacturer must, at no additional cost, furnish the services of trained personnel to the purchaser at the airport and at a time and place agreed to by all parties. These individuals must provide instruction to airport personnel sufficient for the personnel to familiarize themselves with the operation and maintenance of the carrier vehicle and its auxiliary equipment. The period of instruction must not be less than 2 consecutive days, 8 hours per day, with one day dedicated to operation and the second day dedicated to maintenance/operations. Provide 2 sets of maintenance and operation manuals with the unit.

FAA AC 150/5220-20A

Appendix 2. Optional/Alternate Equipment Specification

A2-1. General.

Most snow and ice control equipment is designed to operate under normal winter conditions. At various times, working tolerances and/or severe weather or operating conditions require specialized support equipment to assist the primary unit prior to or during operation. Several of these options are discussed below:

A2-2. Carrier vehicle.

Equipment to be considered when operating a carrier vehicle at or below -40°F or when the vehicle must be stored outside or in an unheated building is as follows:

- a. Engine/transmission.
 - 1) The carrier vehicle engine shall have the following features:
 - Four stroke diesel, six (6) cylinders minimum with individual cylinder heads and 4 valves per cylinder.
 - Minimum of 500 horsepower at 1800 to 2100 rpm and developing a minimum of 1,700-foot pounds of torque at 1200 to 1400 rpm. Engine governed RPM of 2100.
 - The engine shall be proven to be compliant with Tier 4 Final (EU Stage IV) emissions levels per the EPA. The unit will be classified as "off road".
 - Electronic engine management system.

- Extra high pressure fuel injection system.
- Turbo charger with variable gate timing.
- Fuel filter with extra pre-filter and water separator.
- Centrifugal oil filter. OEM per engine manufacturer.
- Oil cooler, oil filler in the valve cover, oil sump, oil dipstick in the engine block, magnetic oil plug for oil draining.
- Starter and electrical system shall be 12 or 24 volt DC.
- Alternator to be single pole, 100 amperes.
- Exhaust gas recirculation emission control system or manufacturer's standard design.
- Diesel particulate filtration (DPF) for emission control is not preferred for this engine configuration. If one engine requires DPF for emission control, it is our preference that it be used on the auxiliary engine.
- Dry type two stage air cleaner. Engine air intake filter canister (s) shall be located under the chassis engine hood on stand away brackets to avoid snow build up on exposed mechanisms.
- A black painted stainless steel exhaust guard shall cover the external exhaust components to protect crew from burns if required by design.
- 1500 watt block type engine coolant heater shall be provided on the vehicle drive engine.
- Side access drain valves shall be provided for the drive engine oil, and preferred for the coolant and hydraulic oil. These drain valves shall be easily accessible under the vehicle below the frame rail.

b. Vehicle cab.

- 1) Forward mounted cab design with good visibility with rear mounted carrier engine.
- 2) Handles must be installed on lower part of vehicle cab door.
- 3) Access steps and grab bars.
- 4) Cab heating, defrosting & air conditioning systems, digital
- 5) Stainless Steel Mirrors or manufacturer's standard design.
 - a) Remote control for exterior mirrors (both sides).
 - b) Electrically heated exterior mirrors (both sides).
- 6) Windows.
 - a) Heated windshield, side window defrosters.
 - b) Extra window in lower part of passenger cab door.
 - c) Tinted windshield and windows.
 - d) Windshield washer
- 7) Seats.
 - a) Arm rests
 - b) Driver seat only, Air suspension seat, high back with headrest c) Passenger jump seat to the left of the driver.
- 8) Cab insulation upgrade (to reduce exterior noise below 85 dBa).
- 9) Air horn
- 10) 10-pound fire extinguisher, inside cab mounted.
- 11) AM/ FM Radio/ Bluetooth

12) Full instrumentation panel with gauges, and warning icons to include:

- Low Air Pressure
- ABS Fail
- ABS Communication Lost
- Engine Stop
- Engine fail warning
- Low voltage
- Engine overheat
- Engine low oil pressure
- Engine air intake restriction
- Transmission overheat
- Transmission fail
- Engine communication lost
- Control system node communication lost
- Transmission Communication lost
- Parking brake applied
- Transmission range
- Traction lock engaged
- Windshield washer fluid low level indicator
- Message center for fault messages affecting operation
- Diesel Exhaust Fluid level gauge
- Diesel Exhaust Fluid level icon
- Diesel Particulate Filter lamp
- High exhaust temperature lamp
- Hydraulic temperature warning
- Hydraulic fluid level low
- Left and Right turn indicators
- High beam indicator

13) Aviation mobile air band radio and airport operations mobile radio

14) Digital Clock

15) Outside air temperature gauge

16) Cup holders (minimum 2)

17) Power outlets (minimum 2)

18) Lighting

- a) Lighting must at a minimum meet the requirements of AC 150/5210-5D for Airfield Service Vehicles
- b) Shall be one (1) – mini bar strobe yellow strobe lights mounted on light bar that is mounted on the uppermost portion of the vehicle structure to be visible 360 degrees and from the air.
- c) Heated roof mounted or side light bar LED exterior lights.
- d) Cab dome lights, door lights
- e) Rear work lights activated in reverse

- f) LED amber snow plow lights on a cab light bars
- g) HID lights on the cab light bars
- h) LED work lights on the cab light bar
- i) Two multipurpose type work-lights to be mounted under the chassis drive engine hood with individual on/off switches and overriding switch for the pair.
- j) Two LED type lights to be mounted under the auxiliary engine cover with an on/off switch near each light that turns on the pair.
- k) Lighting shall have cab mounted switches.

c. Mechanical.

- 1) Battery system will have an easy access Master Disconnect Switch located in the cab, in the battery box or in a easily accessible weatherproof enclosure. The master switch shall be clearly labeled, and have a time delay to account for Manufacturers DPF shut down time.
- 2) Engine/ transmission cooling.
 - a) The cooling system shall consist of a HEAVY DUTY radiator and engine air charge cooler assembly. The charge air cooler (CAC) shall be mounted above or adjacent to the coolant radiator core to optimize air flow and reduce the opportunity to collect snow and other debris between the cooling cores. The coolant and air flow shall be optimized and as recommended by the manufacturer to ensure effective cooling. The tanks and side members shall be bolted together to form a rigid frame with sturdy steel supports. Rubber vibration isolating pucks shall be located below the radiator assembly at the frame to reduce vibration transmitted to the radiator. There shall be at least one support bracket on left and right of radiator, providing stability for the cooling package.
 - b) A thermostatically controlled, air operated disconnect or hydraulic type suction fan shall be provided. If required by design, an engine mounted fan ring shall attach to the cooling system radiator and charge air cooler through a flexible rubber material. Radiator shroud is required to properly direct air flow through cooling system. Normal operational engine movement shall not put undue stresses into the cooling system radiator or charge air cooler.
 - c) The engine cooling system shall be filled with permanent type antifreeze protecting the system to -40 degrees F. A spin on coolant filter and silicone radiator and heater hoses shall be provided.
 - d) If required by design, a fan belt shall be serpentine or V type. Engine shall be equipped with an automatic belt tensioning device. Alternatively, fans may be hydraulically driven.
- 3) On-Board Diagnostics And Electronic Control System:
 - a. Functional control of vehicle shall be centered on an electronic control system. Electronic control systems shall include on board diagnostic assistance and other features to simplify the operation, troubleshooting, and repair of the unit. Electronic control modules shall be of the highest reliability and durability for use in mobile equipment. High amp manual

resettable circuit breaker protection is required upstream from the electronic control modules.

b. On Board Diagnostics Features and Performance:

- Electronic control system shall include and enable diagnosis of chassis systems and function by means of the LCD dash display. Engine and transmission diagnosis shall be accessible via accessible connect ports on vehicle. System shall include the following at a minimum:

1. Message area on LCD to display error message to operator as any system function fails. Available during operation on operations screen.
2. Error message toggle if more than one failure is present.
3. Memory retention of failures until cleared by maintenance personnel with password access.
4. Real time operational indicator of system function on diagnostics/maintenance screens.

4) Automatic engine shutdown. An automatic engine shutdown system is equipped with an override switch and/or a Diesel Electronic Control and Engine Management System to prevent engine damage due to low engine oil pressure, high coolant temperature, or low coolant level.

5) Four Wheel Steering System:

- a. Front axle steering shall be hydraulic power assist gear type. The steering gear shall be rated for heavy duty service. Four wheel steering shall be electronically coordinated through the standard steering wheel. A selector switch within easy reach of the operator shall provide the option of front steer only, crab steer, or coordinated front/rear steer. Additionally, a single axis joystick shall be provided for controlling rear steer only.
- b. An indicator shall be provided in the cab to display mode selected and rear wheel position. Also for safety, there shall be a mechanical linkage maintained at all times between the steering wheel in the cab and the front axle to assure the ability to control the vehicle in the event of hydraulic or electrical system failure. Safety dampening of all wheel steer effects shall be related to vehicle speed and all wheel steer be available in both transfer case speed ranges.
- c. Due to the conditions under which the vehicle will be operated the ability of this equipment to operate safely at all speeds while maximizing maneuverability, and provide the operator the ability to select the desired mode of operation "on the go" an electronically controlled rear axle steering system which operates in conjunction with the mechanically controlled front wheel steering system is required. This system must consist of the following components and operating features.
- d. The all-wheel steering system consists of the following major components:

- The vehicle's original front steering system.
 - A driving, steerable rear axle.
 - Various hydraulic control valves, wheel position sensors, speed sensor and a steering cylinder located on the rear axle.
 - ECU (electronic control unit) and control panel (located in the cab).
 - All of the all-wheel steering system controls are to be located in the cab easily accessible to the operator.
 - The all-wheel steering system must be preprogrammed with multiple steering modes for improved maneuverability.
 - The system must be functional in both high range and low range of the transfer case.
 - A rear wheel position gage located within an easily viewed position of the operator to provide the operator with an gage of rear wheel cramp position.
- 6) Silicone hoses.
 - 7) Provide additional corrosion protection conforming to Fed. Spec. 297D, "Rust-proofing of commercial vehicles".
 - 8) Quick hitch for interchangeability of front mounted snow removal implements.

A2-3. High-speed rotary plow.

- a. Refer to appendix 3, Part A.

AC 150/5220-20A

Appendix 3. High-Speed Rotary Plow Specification

Part A – Airport Operator Checklist

A3-1. Anticipated uses and or features of snow blower: The snow blower shall be used to move snow during large and small snow events at the airport. The carrier vehicle and plow shall be heavy duty to withstand the extreme winter conditions found in the airport environment. This unit is primarily used in large open area snowplowing operations that require a high-volume and high-speed snow discharge for windrows created at the edge of pavement from plows.

A3-2. Size of priority 1 paved area: N/A

A3-3. Capacity: 5,000 tons/hour

A3-4. Casting Distance: Up to 200 feet, 75 feet minimum. The performance specifications are based on snow with a unit weight of 25 pounds per cubic foot.

A3-5. Anticipated speed of operation: 0-45 miles per hour minimum.

A3-6. Unusual conditions/problems/obstructions: The airport has normal obstructions expected to be found at any municipal airport. The snow blower must work well to clear snow of all densities and sheer strengths.

A3-7. Equipment:

1) Two stage rotary snow blower:

- a. The rotary snow blower shall be a two-stage unit including an auger or ribbon, and a separate impeller to effectively feed and displace snow and/or ice. The blower unit shall be designed to withstand hard usage, and cold climates. The materials, parts and construction techniques shall conform to the best engineering practices. For operational flexibility, a second gear ratio shall be provided to provide a longer cast distance or manufacturer's standard design.
- b. The blower shall be a helical ribbon auger first stage with a second stage impeller. Both the auger and impeller shall be driven off the auxiliary engine. The first-stage ribbon shall act to cut and feed snow to the second stage impeller which shall force the snow out of a snow casting chute.
- c. Rotary-head box shall be fabricated of heavy gauge, high wear, welded alloy steel and moldboard suitable for the type of expected service and formed to the contour of the ribbon reel conveyor. Provisions on the box shall be made for vehicle mounts, skid pad and caster brackets, scraper blades and associated hardware, drives, and controls.
- d. A steel scraper blade shall be fitted to the lower leading edge of the rotary head box with approximately 30° attack angle at the moldboard. The blade shall run the entire box width and be of a removable design. Replaceable skid shoes shall be provided at either end of the head to protect the scraper blade and blower housing from excessive wear.
- e. To maximize traction in the work mode, the blower chassis shall be equipped with a weight transfer system. This shall be accomplished hydraulically by sensing the system pressure and continually adjusting the pressure via electronically controlled hydraulic metering valves.
- f. If required by design, a minimum of two (2) rubber tired caster wheels shall be provided on the blower head capable of swiveling 360 degrees for backing. The tires shall have a minimum load capacity to support the unit and be rated for 30 MPH service at full load. The caster wheels do not need to rotate 360 degrees for backing if not required by design.

2) Helical Ribbon:

- a. The helical serrated ribbon shall have a minimum of two bearing supports, one at each end of the reel, and be driven from both ends. **SINGLE MOTOR DRIVE IS UNACCEPTABLE AND WILL NOT BE CONSIDERED.** Likewise, open prop shaft drive within the path of snow flow is unacceptable. If the dual motor drive is provided at the center,

driving outward, prop shaft and/or drive mechanism must be in an enclosed case. Dual motor drive is essential for reliability and performance. Single motor drive is unacceptable. Motors shall be variable displacement type with electronic control system. The serrated ribbon flights on each reel shall be two removable halves and mounted on the reel shaft by the necessary number of mounts with flat or flange head fasteners. The serrated reel shall be constructed with a curb ring for protection to any exposed parts of the reel. A minimum of clearance shall exist between the rotary head box and the reel to reduce snow plowing and carryover. Reel speed shall be selectable by the seated operator for variable snow and operating conditions without varying the impeller speed and cast distance. Operator shall be able to select from multiple speed settings correlating to ground speed required. Ribbon speed shall automatically adjust to torque loads generated by snow input with the selected speed being the highest speed enabled.

- b. The reel shall be driven **hydrostatically** and be reversible from the cab to aid in disgorging excessive or clogged snow from the head by means of momentary electric rocker switch convenient to the operator. Pump shall be electronically controlled. Hydrostatic relief shall be provided to protect the system should ingestion of foreign objects occur. A low oil level/high oil temperature warning system shall alert the operator in the cab to abnormal conditions. Provisions shall be made so minimal hydraulic fluid is lost during routine filter changes. A suction screen shall be installed at the outlet of the hydraulic reservoir to provide protection to the main hydraulic pump. **Mechanically driven systems are not allowed.**

3) Impeller System:

- a. The impeller system shall be designed to be consistent with the capacity of the in-putting reel. The opening, blade diameter and speed ratio shall ensure proper snow flow and discharge to the casting chute. The five impeller blades must be replaceable and be attached with countersunk fasteners. All blades shall be constructed and balanced to be resistant to vibration and shock damage caused by high speed ingestion of foreign objects. The impeller shall be driven by direct mechanical means.
- b. The blower drive shall include a full torque PTO clutch, controlled from the cab, for blower drive engagement. Clutch engagement shall be electric over air actuated and provide protection against engaging clutch when blower engine is over 800 min rpm. Ribbon status icon on the LCD will clearly indicate ribbon status as a visual reminder to operator of the status. Clutch shall automatically disengage if engine is shut off to avoid attempts at start up with impeller engaged.
- c. A two-speed reduction gear system shall be provided between the blower engine and the impeller to provide proper torque and speed at the impeller while allowing the engine to operate at the RPM providing maximum efficiency or manufacturer's standard design. An electronically

controlled lock out system shall automatically assure that gear change is made only with clutch disengaged and shaft movement at low enough speeds to avoid damage to gear system. Shift pattern to be the manufacturers' standard. For vehicle and equipment protection, if the shift is not completed within approx. 1.5 minutes, the system shall cease attempts at range shift and notify the operator of the failure by flashing light at the control switch. The operating range of the drop box is to be displayed on the main dash LCD screen.

- d. The gear box shall include helical gears with pressurized lubrication system. CHAIN TYPE DROP BOXES ARE NOT ACCEPTABLE. Shear bolts shall be provided in the impeller drive train to minimize damage should ingestion of foreign objects occur. The shear bolts shall be accessible and replaceable from behind the intake face of the blower to eliminate removing snow from the blower intake to replace the bolts.
 - e. The snow casting assembly shall consist of a controllable chute, impeller or turbine snow collector and a control system. The system shall be designed to accept the maximum output volume of the impeller assembly, with an interior free from sharp bends or obstructions.
 - f. The casting chute assembly shall rotate in a vertical plane to cast snow to the left or right side of the vehicle thru a minimum arc of 125 degrees. **It shall flat cast to the left.**
 - g. The rotary head assembly shall have a provision for raising the head from the pavement. The hydraulic lift mechanism shall be fully operable from the control cab, with hydraulic pump driven by the chassis engine. Rotary head drive system shall not bind, rub or vibrate excessively when head is raised to maximum height and shall be able to travel a minimum of 2" below ground level to clean out surface depressions.
- 4) The auxiliary engine shall have the following features:
- Four stroke diesel with individual cylinder heads and 4 valves per cylinder, wet cylinder liner design.
 - Minimum 650 horsepower at 1800 rpm. Engine governed RPM of 2100. Note that this is the minimum HP allowed. A larger engine shall be provided if it is required and determined by the manufacturer to fully meet the 5,000 TPH requirement.
 - The engine shall be proven to be compliant with Tier 4 Final (EU Stage IV) emissions levels per the EPA.
 - Electronic engine management system.
 - Extra high pressure fuel injection system.
 - Turbo charger with variable gate timing.
 - Fuel filter with extra pre-filter and water separator.
 - Centrifugal oil filter. OEM per the engine manufacturer.
 - Oil cooler, oil filler in the valve cover, deep front oil sump, oil dipstick in the engine block, magnetic oil plug for oil draining.
 - Starter and electrical system shall be 12 or 24 volt DC.
 - Starter to be single pole, 6.0 KW.

- Alternator to be single pole, 100 amperes.
- Exhaust gas recirculation emission control system or manufacturer's standard design.
- Diesel particulate filtration (DPF) for emission control is not preferred for this engine configuration. If one engine requires DPF for emission control, it is our preference that it is to be used on the auxiliary engine. If DPF is required, use the manufacturer's standard design.
- Dry type two stage air cleaner.
- A black painted stainless steel exhaust guard shall cover the external exhaust components to protect crew from burns if required by design. 1500 watt block type engine coolant heater shall be provided on the engine.
- Side access drain valves shall be provided for the drive engine oil, coolant and hydraulic oil. These drain valves shall be easily accessible under the vehicle below the frame rail.
- Electronic engine controls with on-board diagnostics integral.

5) Cooling System:

- a. The cooling system shall consist of a HEAVY DUTY radiator and engine air charge cooler assembly. The charge air cooler (CAC) shall be mounted above or adjacent to the coolant radiator core to optimize air flow and reduce the opportunity to collect snow and other debris between the cooling cores. The coolant and air flow shall be optimized and as recommended by the manufacturer to ensure effective cooling. The tanks and side members shall be bolted together to form a rigid frame with sturdy steel supports. Rubber vibration isolating pucks shall be located below the radiator assembly at the frame to reduce vibration transmitted to the radiator. There shall be at least one support bracket on left and right of radiator, providing stability for the cooling package.
- b. A thermostatically controlled, air operated disconnect or hydraulic type suction fan shall be provided. Radiator shroud is required to properly direct air flow through cooling system. If required by design, an engine mounted fan ring shall attach to the cooling system radiator and charge air cooler through a flexible rubber material. Normal operational engine movement shall not put undue stresses into the cooling system radiator or charge air cooler.
- c. The engine cooling system shall be filled with permanent type antifreeze protecting the system to -40 degrees F. A spin on coolant filter and silicone radiator and heater hoses shall be provided.
- d. If required by design, a fan belt shall be serpentine or V type. Engine shall be equipped with an automatic belt tensioning device. Alternatively, fans may be hydraulically driven.
- e. Manufacture shall supply four extra dolly wheels, one extra steel scraper blade, and fifty extra shear bolts.

AC 150/5220-20A
Appendix 3. High-Speed Rotary Plow Specification
Part B – Snow Plow Specification

A3-8. See paragraph 3.3 of FAA AC 150/5320-20A.

A3-9. High-speed rotary plows and carrier vehicles must be in accordance with SAE ARP 5539, Rotary Plow with Carrier Vehicle. Additional Federal AIP/PFC specification requirement for SAE ARP 5539 is that for carrier vehicle controllability and safety, all-wheel drive must be provided.

EXHIBIT D: DOCUMENTS REQUIRED TO BE SUBMITTED WITH BID

1. Bid Acknowledge Form
2. Offerer Disclosure of Prior Non-Responsibility Determinations
3. Non-Collusion Affidavit
4. References
5. Bid Sheet(s)
6. Exceptions (To be submitted by bidder)
7. Buy American Certification
8. Certifications
9. Receipt of Addenda
10. Iranian Energy Sector Divestment Statement
11. Compliance with Iran Divestment Statement
12. Operational Standards and Compliance Testing

EXHIBIT D: BID ACKNOWLEDGEMENT FORM

The Bidder acknowledges that he/she has carefully read the IFB and understands the specifications requested.

The Bidder warrants that if the Bid is accepted, he/she will contract with the Albany County Airport Authority using a Purchase Order and comply with the requirements of the IFB and the Terms and Conditions attached to the Purchase Order.

Name of Bidder: M-B Companies, Inc.

Signature of Authorized Person: 

Print Name and Title: Joshua Abler, Inside Sales Manager MB

Business Address of Bidder: 1615 Wisconsin Avenue
New Holstein, WI 53061

Business Phone Number: (920) 898-1011

Business Fax Number: (920) 849-2629

Business E-Mail Address: josh.abler@aebi-schmidt.com

Date: 7/29/2024

Subscribed and sworn to before me this 29th day of July, 2024.



Notary Public William M. Hecker



EXHIBIT D:

OFFERER DISCLOSURE OF PRIOR NON-RESPONSIBILITY DETERMINATIONS

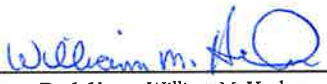
Name of Individual or Entity Seeking to Enter into the Procurement Contract:

M-B Companies, Inc.

Address: 1615 Wisconsin Avenue

New Holstein, WI 53014

Name and Title of Person Submitting this Form: Joshua Abler

Inside Sales Manager MB

Contract Procurement Number: E-1194

Date: 7/29/2024

1. Has any Governmental Entity made a finding of non-responsibility regarding the individual or entity seeking to enter into the Procurement Contract in the previous four years? (Please circle):

No Yes

If yes, please answer the next questions:

2. Was the basis for the finding of non-responsibility due to a violation of State Finance Law §139-j (Please circle):

No Yes

3. Was the basis for the finding of non-responsibility due to the intentional provision of false or incomplete information to a Governmental Entity? (Please circle):

No Yes

4. If you answered yes to any of the above questions, please provide details regarding the finding of non-responsibility below.

Governmental Entity: N/A

Date of Finding of Non-responsibility: N/A

Basis of Finding of Non-Responsibility: N/A

(Add additional pages as necessary)

5. Has any Governmental Entity or other governmental agency terminated or withheld a Procurement Contract with the above-named individual or entity due to the intentional provision of false or incomplete information? (Please circle):

No

Yes

6. If yes, please provide details below.

Governmental Entity: N/A

Date of Termination or Withholding of Contract: N/A

Basis of Termination or Withholding: N/A

(Add additional pages as necessary)

Offerer certifies that all information provided to the Governmental Entity with respect to State Finance Law §139-k is complete, true and accurate.

By:  Date: 7/29/2024
Signature

Name: Joshua Abler

Title: Inside Sales Manager MB

EXHIBIT D: NON-COLLUSION AFFIDAVIT

AUTHORIZED OFFICER: Bidder's submittal containing statements, supporting documentation, letters, etc., shall be signed in the bid by a duly authorized officer of the company whose signature is binding on the bid.

The undersigned offers and agrees to furnish the equipment upon which specifications are stated in the enclosed bid. The period of acceptance of this bid will be ___ calendar days from the date of the acknowledgment. (Period of acceptance will be forty-five (45) calendar days unless otherwise indicated by Bidder).

STATE OF Wisconsin COUNTY OF Calumet
BEFORE ME, the undersigned authority, a Notary Public in and for the State of Wisconsin
_____ on this day personally appeared Joshua Abler who after
being by me duly sworn did depose and say: I, Joshua Abler am a duly
authorized officer of/agent for M-B Companies, Inc. and have been
duly authorized to execute the foregoing on behalf of the said

I hereby certify that the foregoing offer has not been prepared in collusion with any other proponent or other person or persons engaged in the same line of business prior to the official opening of this Bid. Further, I certify that the proponent is not now, nor has been for the past six (6) months, directly or indirectly concerned in any pool or agreement or combination, to control the type of equipment offered, or to influence any person or persons to offer or not to offer thereon.

By submission of this bid, the Bidder and each person signing on behalf of the Bidder certifies and in the case of a joint Bid each party thereto certifies as to its own organization, under penalty of perjury that to the best of his knowledge and belief:

- A. The prices in this Bid have been arrived at independently without collusion, consultation, communication or agreement for the purpose of restricting competition as to any matter relating to such prices with any other Bidder or with any competitor;
- B. Unless otherwise required by law, the prices which have been quoted in this Bid have not been knowingly disclosed by the Bidder and will not knowingly be disclosed by the Bidder prior to the opening, directly or indirectly to any other Bidder or to any competitor; and,

C. No attempt has been made or will be made by the proponent to induce any other person, partnership or corporation to submit or not to submit a proposal for the purpose of restricting competition.

Name and Address of Bidder: M-B Companies, Inc.

1615 Wisconsin Avenue

New Holstein, WI 53061

Telephone and Fax Numbers: 920-898-1011 and 920-849-2629

E-Mail Address: josh.abler@aebi-schmidt.com

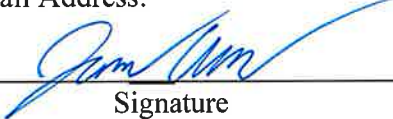
By:  Name and Title: Joshua Abler, Inside Sales manager MB
Signature

SUBSCRIBED AND SWORN to before me by the above-named on this 29th day of July, 2024.



William M. Hecker

Notary Public in and for the Wisconsin for the M-B Companies, Inc.



EXHIBIT D: REFERENCES

List three (3) businesses where like or similar equipment has been provided within the last two (2) years:

1. **Company Name:** _____ (See Attached)
Address: _____
Contact Person and Title: _____
Phone / Fax/ E-Mail _____
2. **Company Name:** _____ (See Attached)
Address: _____
Contact Person and Title: _____
Phone / Fax/ E-Mail _____
3. **Company Name:** _____ (See Attached)
Address: _____
Contact Person and Title: _____
Phone / Fax/ E-Mail _____



MB4 Two Engine Chassis Mounted Snowblower



a brand of aeabi schmidt

Nov-20	Flagstaff Airport	AZ	Tim Skinner	Tskinner@flagstaffaz.gov	928-213-2931	4000 TPH, 22' front broom, 22' Plow	08-0494
Dec-20	Harbin Taiping International Airport	China				4000 TPH	08-0493
Dec-20	DuPage Airport	IL	Mike Bross	mbross@dupageairport.com	815-762-4414	7500 TPH	08-0503
Jan-21	Chicago Rockford Int'l Airport	IL	Matt Zinke	mzinke@flyrfd.com	815-696-4022	7500 TPH	08-0519
Feb-21	Chicago Rockford Int'l Airport	IL	Matt Zinke	mzinke@flyrfd.com	815-696-4022	7500 TPH	08-0520
Feb-21	John Glenn International Airport	OH	Jay Stowe	stowe@columbusairports.com	614-239-4023	7500 TPH	08-0514
Mar-21	John Glenn International Airport	OH	Jay Stowe	stowe@columbusairports.com	614-239-4023	7500 TPH	08-0515
Mar-21	John Glenn International Airport	OH	Jay Stowe	stowe@columbusairports.com	614-239-4023	7500 TPH	08-0516
Mar-21	Bismarck Municipal Airport	ND	Troy Estes	tjestes@bismarcknd.gov	701-220-6502	5500 TPH	08-0504
May-21	Anchorage Int'l Airport	AK	Phil Petri	phil.petri@alaska.gov	907-266-2427	7500 TPH	08-0533
Jul-21	Pittsburgh International Airport	PA	Mick Halikos	mhalikos@flypittsburgh.com	412-472-5651	7500 TPH	08-0545
Jul-21	Aberdeen Regional Airport	SD	Richard Krokkel	rich.krokkel@aberdeen.sd.us	605-228-7680	4000 TPH	08-0550
Aug-21	Lambert St Louis Int'l Airport	MO	Mike Bernich	mabernich@flystl.org	314-426-8062	7500 TPH	08-0559
Sep-21	Chicago Executive Airport	IL	Andrew J. Wolanik	aWolanik@chixec.com	847-833-7386	7500 TPH	08-0563
Oct-21	Dane County Regional Airport	WI	Greg Kerkenbush	kerkenbush@msnairport.com	608-575-3396	7500 TPH	08-0562
Oct-21	Friedman Memorial Airport	ID	Chris Pomeroy	Chris@jflysun.com	208-788-4956	7500 TPH	08-0562
Oct-21	Roanoke Regional Airport	VA	Matt Humphreys	matt.humphreys@flyroa.com	540-309-73113	7500 TPH	08-0583
Oct-21	Boise Airport	ID	Shaun McKay	smckay@cityofboise.org	208-593-1868	7500 TPH	08-0581
Nov-21	Capital Regional Airport	MI	Steve Ball	sball@craa.com	517-819-9582	4000 TPH	08-0584
Sep-22	Grand Forks Regional Airport	ND	Joey Castiglione	jcastiglione@grfairport.com	701-738-4644	7500 TPH	
Sep-22	Central Nebraska Regional Airport	NE	Wes Harris	wes@flygrandisland.com	308-380-8416	4000 TPH	
Dec-22	DFAS - Luxembourg	LU				4000 TPH	
Dec-22	DFAS - Luxembourg	LU				4000 TPH	
Dec-22	DFAS - Luxembourg	LU				4000 TPH	
Dec-22	King County International Airport	WA	Donald McClendon	dmcclendon@kingcounty.gov	206-225-1715	7500 TPH	
Jan-23	Valdez Airport	AK				7500 TPH, 18' Front broom	
Feb-23	Anchorage Int'l Airport	AK	Phil Petri	phil.petrie@alaska.gov	907-266-2427	7500 TPH	
Feb-23	Anchorage Int'l Airport	AK	Phil Petri	phil.petrie@alaska.gov	907-266-2427	7500 TPH	
Feb-23	Anchorage Int'l Airport	AK	Phil Petri	phil.petrie@alaska.gov	907-266-2427	7500 TPH	
Mar-23	Gary-Chicago International Airport	IN	Ken Cast		219-949-4902	7500 TPH	
Mar-23	Greenland-NUUK					7500 TPH	
Mar-23	Chicago O'Hare Airport	IL	Jeffrey Jurek	jeffrey.jurek@cityofchicago.org	773-838-0636	7500 TPH	
Mar-23	Chicago O'Hare Airport	IL	Jeffrey Jurek	jeffrey.jurek@cityofchicago.org	773-838-0636	7500 TPH	
Mar-23	Chicago O'Hare Airport	IL	Jeffrey Jurek	jeffrey.jurek@cityofchicago.org	773-838-0636	7500 TPH	
Apr-23	Chicago O'Hare Airport	IL	Jeffrey Jurek	jeffrey.jurek@cityofchicago.org	773-838-0636	7500 TPH	



MB4 Two Engine Chassis Mounted Snowblower



a brand of aeabi schmidt

May-23	Salt Lake City Airport	UT							7500 TPH
May-23	Chicago O'Hare Airport	IL	Jeffrey Jurek	jeffrey.jurek@cityofchicago.org	773-838-0636				7500 TPH
May-23	Chicago O'Hare Airport	IL	Jeffrey Jurek	jeffrey.jurek@cityofchicago.org	773-838-0636				7500 TPH
Jun-23	Sawyer International Airport	MI							7500 TPH
Jun-23	Deadhorse Airport	AK							7500 TPH, 20' Front broom
Jul-23	Lambert St Louis Int'l Airport	MO	Rick Rasensmeyer		314-606-0007				7500 TPH
Aug-23	Sioux Gateway Airport	IA							4000 TPH
Nov-23	Denver Int'l Airport	CO	Steve Ricci	steven.ricci@flydenver.com	720-391-5946				7500 TPH
Dec-23	Duluth International Airport	MN	Dan Taylor	dtaylor@duluthairport.com	218-391-5670				7500 TPH
Dec-23	Portsmouth International Airport	NH	KC Conley	K.Conley@peasedev.org	603-234-5307				7500 TPH
Jan-24	Sheboygan County Memorial Airport	WI	Matt Grenoble	matthew.grenoble@sheboygancounty.com	920-467-8052				3000 TPH, 18' Front broom
Jan-24	Milwaukee County Airport	WI	Tim Brown	tbrown@mitchellairport.com	414-747-5324				7500 TPH
Apr-24	Mansfield Lahm Airport	OH	Mark Daugherty	mداugherty@ci.mansfield.oh.us	419-522-2191				4000 TPH, 18' Front broom
May-24	Clinton National Airport	AR							7500 TPH
May-24	City of Hailey	ID							7500 TPH
TBD	Anchorage Int'l Airport	AK	Phil Petri	phil.petrie@alaska.gov	907-266-2427				7500 TPH
TBD	Denver Int'l Airport	CO	Steve Ricci	steven.ricci@flydenver.com	720-391-5946				7500 TPH
TBD	Denver Int'l Airport	CO	Steve Ricci	steven.ricci@flydenver.com	720-391-5946				7500 TPH
TBD	Minneapolis St Paul Int'l Airport	MN							7500 TPH
TBD	Minneapolis St Paul Int'l Airport	MN							7500 TPH
TBD	Glacier Park International Airport	MT							7500 TPH
TBD	Glacier Park International Airport	MT							20' Front broom
TBD	Bert Mooney Airport	MT							7500 TPH, 20' Front broom
TBD	Bozeman Yellowstone Int'l Airport	MT							7500 TPH, 20' Front broom
TBD	Bozeman Yellowstone Int'l Airport	MT							7500 TPH, 20' Front broom
TBD	Bozeman Yellowstone Int'l Airport	MT							7500 TPH, 20' Front broom
TBD	Buffalo Niagara International Airport	NY							7500 TPH
TBD	Martha's Vineyard Airport	MA							4000 TPH, 18' front broom, 18' FOD Box
TBD	Minot International Airport	NM							7500 TPH
TBD	Billings Logan International Airport	MT							7500 TPH
TBD	Oakland County Airport	MI							7500 TPH
TBD	Range Regional Airport	MN							7500 TPH
TBD	Akron-Canton Airport	OH							7500 TPH
TBD	Minneapolis St Paul Int'l Airport	MN							7500 TPH
TBD	Minneapolis St Paul Int'l Airport	MN							7500 TPH

MB4 Two Engine Chassis Mounted Snowblower



TBD	Minneapolis St Paul Int'l Airport	MN					7500 TPH
TBD	Wiley Post-Will Rogers Memorial Airport	AK					5000 TPH, 18' Front broom
TBD	Indianapolis Int'l Airport	IN					7500 TPH
TBD	Pangborn Memorial Airport	WA					7500 TPH
TBD	Casper/Natrona County Airport	WY					7500 TPH
TBD	Ronald Reagan Washington National Airport	DC					7500 TPH
TBD	Ronald Reagan Washington National Airport	DC					7500 TPH
TBD	Dallas Love Field	TX					7500 TPH, 20' Front broom
TBD	Aspen/Pitkin County Airport	CO					7500 TPH
TBD	Denver Int'l Airport	CO	Steve Ricci		steven.ricci@flydenver.com	720-391-5946	7500 TPH
TBD	Denver Int'l Airport	CO	Steve Ricci		steven.ricci@flydenver.com	720-391-5946	7500 TPH
TBD	Salt Lake City Airport	UT					7500 TPH
TBD	Burlington International Airport	VT					7500 TPH
TBD	Centennial Airport	CO					7500 TPH
TBD	Bishop International Airport	MI					7500 TPH, 22' Front broom
TBD	Williston Basin International Airport	ND					7500 TPH
TBD	Epply Airfield	NE					7500 TPH
TBD	Cheyenne Regional Airport	WY					7500 TPH, 20' Front broom, 20' FOD Box
TBD	SEATAC Int'l Airport	WA					7500 TPH
TBD	SEATAC Int'l Airport	WA					7500 TPH
TBD	Lambert St Louis Int'l Airport	MO					7500 TPH
TBD	Lambert St Louis Int'l Airport	MO					7500 TPH
TBD	Schenectady County Airport	NY					7500 TPH
TBD	JFK International Airport-PANYNJ	NY					7500 TPH
TBD							
TBD							
TBD							

EXHIBIT D: BID SHEET(S)

1. COMPLIANCY

Listed in EXHIBIT C-1 are the minimum specifications and standards intended to govern, in general, the One (1) 2024 or newer airport carrier vehicle with high speed snow blower. Please check "Yes; or "No" if you can meet these specifications and standards. Variations offered as "or equal" should include a justification for each to be used in the evaluation of the equipment offered. The Authority reserves the right to make the final determination if the "as equal" variation is acceptable to the Authority.

All requirements of the Minimum Specifications and Standards will be met:

YES _____ NO X

If no, each exception should be listed together with explanation in # 4 below.

2. EQUIPMENT PRICING

Make/Model of Airport Carrier Vehicle with High Speed Snow Blower:

M-B Companies, Inc., MB4

Price:	Base Bid Price	\$ <u>900,529.00</u>
	Shipping / Delivery Cost	\$ <u>13,000.00</u>
	TOTAL	\$ <u>913,529.00</u>

3. DELIVERY

The equipment shall be delivered to Albany International Airport no later than the following date: 500 days A.R.O. (no later than August 1, 2025)

4. MANUFACTURES' VARIANCE INCLUDING "OR EQUAL" SUBSTITUTIONS

ITEM NUMBER	EXPLANATION	PRICE VARIANCE (+ OR-)
<u>(See attached List of Exceptions)</u>		
<hr/>		
<hr/>		

(IF NEEDED, ADDITIONAL PAGES MAY BE ATTACHED)

5. ADDITIONAL AVAILABLE OPTIONS

OPTION ITEM NUMBER	PRICE PER OPTION
N/A	N/A

(IF NEEDED ADDITIONAL PAGES MAY BE ATTACHED)

6. WARRANTY OR WARRANTIES

Please describe each type of warranty available above and beyond the standard warranty period:

(See Attached Definitions Page)

Will warranty services be performed at Albany International Airport: YES X NO ___

Service available with 48 hours (Maximum 48 hours) of notification.

Copies of warranties should be submitted as Exhibit to Bid proposal.

A manufacturer's standard new machine warranty terms, limits, and conditions shall be included with the bid. Said warranty shall provide no less than one (1) year full warranty coverage on the chassis, two (2) years of full warranty coverage the axles and on all attachments. The engine(s) shall carry a minimum five (5) year, 100,000 mile warranty and the transmission shall carry a minimum of five (5) year manufacturer's warranty.

**Albany International Airport, Albany County Airport Authority
Albany, NY, CONTRACT # E-1194,
Airport Carrier Vehicle With High Speed Snow Blower,
Bid Opening Date: August 1, 2024, 11:00 A.M., (EST)**

M-B Companies, Inc. Warranty Definitions

Base Unit Warranty

- 1 year full warranty coverage on the chassis and snow blower
- 2 year warranty coverage on the chassis axles
- 5 year warranty coverage on the chassis and auxiliary engine
- 5 year warranty coverage on the chassis transmission

Type 1 - Extended Warranty

- 1 year - Full warranty coverage on the chassis and snow blower
- 2 year - Full warranty coverage on the chassis and snow blower

At the termination of the standard warranty period, the Authority may seek to purchase extended service for this equipment. Please indicate the cost of this extended service for on site service at the Airport for each available warranty.

TYPE	<u>Type 1</u>	<u> </u>	<u> </u>
1 year	<u>\$ 26,457.00</u>	<u>\$</u>	<u>\$</u>
2 years	<u>\$ 61,732.00</u>	<u>\$</u>	<u>\$</u>
3 years	<u>\$ N/A</u>	<u>\$</u>	<u>\$</u>
4 years	<u>\$ N/A</u>	<u>\$</u>	<u>\$</u>
5 years	<u>\$ N/A</u>	<u>\$</u>	<u>\$</u>

Warranty service availability within 48 hours (Maximum 48 hours) of notification.

Exceptions: (if applicable)

The vendor must clearly cite specific specifications or terms and conditions to which the vendor takes exception. The vendor shall state the exact requirements to which exceptions are taken. Any cost impact with an exception must be identified and included in the pricing section.

(See attached List of Exceptions)

(Include additional pages if necessary)

**Albany International Airport, Albany County Airport Authority
Albany, NY, CONTRACT # E-1194,
Airport Carrier Vehicle With High Speed Snow Blower,
Bid Opening Date: August 1, 2024, 11:00 A.M., (EST)**

Exceptions

Page 9, A, 2, Minimum Qualifications

Specification: Bidder must be able to meet the delivery date of August 1, 2025.

Provided: Bidder will deliver within 500 days of receipt of order.

Note: This includes all future bid specification references to the delivery date of August 1, 2025.

Page 29, DELIVERY METHOD

Specification: The equipment shall be delivered to the Albany International Airport, 130 Sicker Road, Latham NY 12110 no later than 365 days from receipt of order.

Provided: The equipment will be delivered to the Albany International Airport, 130 Sicker Road, Latham NY 12110 no later than 500 days from receipt of order.

EXHIBIT D: BUY AMERICAN CERTIFICATION

The Contractor agrees to comply with 49 USC § 50101, which provides that Federal funds may not be obligated unless all steel and manufactured goods used in AIP funded projects are produced in the United States, unless the Federal Aviation Administration has issued a waiver for the product; the product is listed as an Excepted Article, Material Or Supply in Federal Acquisition Regulation subpart 25.108; or is included in the FAA Nationwide Buy American Waivers Issued list.

A bidder or offeror must complete and submit the Buy America certification included herein with their bid or offer. The Owner will reject as nonresponsive any bid or offer that does not include a completed Certificate of Buy American Compliance.

Certificate of Buy American Compliance for Manufactured Products

As a matter of bid responsiveness, the bidder or offeror must complete, sign, date, and submit this certification statement with their proposal. The bidder or offeror must indicate how they intend to comply with 49 USC § 50101 by selecting one on the following certification statements. These statements are mutually exclusive. Bidder must select one or the other (not both) by inserting a checkmark (✓) or the letter "X".

- Bidder or offeror hereby certifies that it will comply with 49 USC § 50101 by:
 - a) Only installing steel and manufactured products produced in the United States, or;
 - b) Installing manufactured products for which the FAA has issued a waiver as indicated by inclusion on the current FAA Nationwide Buy American Waivers Issued listing, or;
 - c) Installing products listed as an Excepted Article, Material or Supply in Federal Acquisition Regulation Subpart 25.108.

By selecting this certification statement, the bidder or offeror agrees:

1. To provide to the Owner evidence that documents the source and origin of the steel and manufactured product.
2. To faithfully comply with providing US domestic product
3. To furnish US domestic product for any waiver request that the FAA rejects
4. To refrain from seeking a waiver request after establishment of the contract, unless extenuating circumstances emerge that the FAA determines justified.

- The bidder or offeror hereby certifies it cannot comply with the 100% Buy American Preferences of 49 USC § 50101(a) but may qualify for either a Type 3 or Type 4 waiver under 49 USC § 50101(b). By selecting this certification statement, the apparent bidder or offeror with the apparent low bid agrees:

1. To submit to the Owner within 15 calendar days of the bid opening, a formal waiver request and required documentation that support the type of waiver being requested.
2. That failure to submit the required documentation within the specified timeframe is cause for a non-responsive determination may result in rejection of the proposal.

3. To faithfully comply with providing US domestic products at or above the approved US domestic content percentage as approved by the FAA.
4. To refrain from seeking a waiver request after establishment of the contract, unless extenuating circumstances emerge that the FAA determines justified.

Required Documentation

Type 3 Waiver - The cost of the item components and subcomponents produced in the United States is more than 60% of the cost of all components and subcomponents of the "item". The required documentation for a Type 3 Waiver is:

- a) Listing of all product components and subcomponents that are not comprised of 100% US domestic content (Excludes products listed on the FAA Nationwide Buy American Waivers Issued listing and products excluded by Federal Acquisition Regulation Subpart 25.108; products of unknown origin must be considered as non-domestic products in their entirety).
- b) Cost of non-domestic components and subcomponents, excluding labor costs associated with final assembly at place of manufacture.
- c) Percentage of non-domestic component and subcomponent cost as compared to total "item" component and subcomponent costs, excluding labor costs associated with final assembly at place of manufacture.

Type 4 Waiver – Total cost of project using US domestic source product exceeds the total project cost using non-domestic product by 25%. The required documentation for a Type 4 Waiver is:

- a) Detailed cost information for total project using US domestic product
- b) Detailed cost information for total project using non-domestic product

False Statements: Per 49 USC § 47126, this certification concerns a matter within the jurisdiction of the Federal Aviation Administration and the making of a false, fictitious or fraudulent certification may render the maker subject to prosecution under Title 18, United States Code.

7/29/2024
Date

Signature Joshua Abler

M-B Companies, Inc.
Company Name

Inside Sales Manager MB
Title

(Buy American form(s) must be completed and submitted with the Bid)

EXHIBIT D: CERTIFICATIONS

BIDDER'S NAME: M-B Companies, Inc.

ADDRESS: 1615 Wisconsin Avenue, New Holstein, WI 53061

TELEPHONE NO.: 920-898-1011 **FAX NO.** 920-849-2629

IRS EMPLOYER IDENTIFICATION NUMBER: 39-1208304

CERTIFICATION OF OFFEROR/BIDDER REGARDING DEBARMENT

By submitting a bid/proposal under this solicitation, the bidder or offeror certifies that neither it nor its principals are presently debarred or suspended by any Federal department or agency from participation in this transaction.

CERTIFICATION OF LOWER TIER CONTRACTORS REGARDING DEBARMENT

The successful bidder, by administering each lower tier subcontract that exceeds \$25,000 as a "covered transaction", must verify each lower tier participant of a "covered transaction" under the project is not presently debarred or otherwise disqualified from participation in this federally assisted project. The successful bidder will accomplish this by:

1. Checking the System for Award Management at website: <http://www.sam.gov>
2. Collecting a certification statement similar to the Certificate Regarding Debarment and Suspension (Bidder or Offeror), above.
3. Inserting a clause or condition in the covered transaction with the lower tier contract

If the FAA later determines that a lower tier participant failed to disclose to a higher tier participant that it was excluded or disqualified at the time it entered the covered transaction, the FAA may pursue any available remedies, including suspension and debarment of the non-compliant participant.

* * * * *

CERTIFICATION REGARDING LOBBYING

The bidder or offeror certifies by signing and submitting this bid or proposal, to the best of his or her knowledge and belief, that:

- (1) No Federal appropriated funds have been paid or will be paid, by or on behalf of the Bidder or Offeror, to any person for influencing or attempting to influence an officer or employee of an agency, a Member of Congress, an officer or employee of Congress, or an employee of a Member of Congress in connection with the awarding of any Federal contract, the making of any Federal grant, the making of any Federal loan, the entering into of any cooperative agreement, and the extension, continuation, renewal, amendment, or modification of any Federal contract, grant, loan, or cooperative agreement.
- (2) If any funds other than Federal appropriated funds have been paid or will be paid to any person for influencing or attempting to influence an officer or employee of any agency, a Member of Congress, an officer or employee of Congress, or an employee of a Member of Congress in connection with this Federal contract, grant, loan, or cooperative agreement, the undersigned shall complete and submit Standard Form-LLL, "Disclosure Form to Report Lobbying," in accordance with its instructions.
- (3) The undersigned shall require that the language of this certification be included in the award documents for all sub-awards at all tiers (including subcontracts, sub-grants, and contracts under grants, loans, and cooperative agreements) and that all sub-recipients shall certify and disclose accordingly.

This certification is a material representation of fact upon which reliance was placed when this transaction was made or entered into. Submission of this certification is a prerequisite for making or entering into this transaction imposed by section 1352, title 31, U.S. Code. Any person who fails to file the required certification shall be subject to a civil penalty of not less than \$10,000 and not more than \$100,000 for each such failure.

* * * * *

CERTIFICATION OF OFFERER/BIDDER REGARDING TAX DELINQUENCY AND FELONY CONVICTIONS

The Contractor must complete the following two certification statements. The Contractor must indicate its current status as it relates to tax delinquency and felony conviction by inserting a checkmark or "X" in the space following the applicable response. The Contractor agrees that, if awarded a contract resulting from this solicitation, it will incorporate this provision for certification in all lower tier subcontracts.

Certifications:

- 1) The Contractor represents that it is () is not () a corporation that has any unpaid Federal tax liability that has been assessed, for which all judicial and administrative remedies have been exhausted or have lapsed, and that is not being paid in a timely manner pursuant to an agreement with the authority responsible for collecting the tax liability.
- 2) The Contractor represents that it is () is not () a corporation that was convicted of a criminal violation under any Federal law within the preceding 24 months.

Note:

If a Contractor responds in the affirmative to either of the above representations, the Contractor is ineligible to receive an award unless the sponsor has received notification from the agency suspension and debarment official (SDO) that the SDO has considered suspension or debarment and determined that further action is not required to protect the Government's interests. The Contractor therefore must provide information to the owner about its tax liability or conviction to the Owner, who will then notify the FAA Airports District Office, which will then notify the agency's SDO to facilitate completion of the required considerations before award decisions are made.

Term Definitions

Felony conviction: Felony conviction means a conviction within the preceding twenty four (24) months of a felony criminal violation under any Federal law and includes conviction of an offense defined in a section of the U.S. code that specifically classifies the offense as a felony and conviction of an offense that is classified as a felony under 18 U.S.C. § 3559.

Tax Delinquency: A tax delinquency is any unpaid Federal tax liability that has been assessed, for which all judicial and administrative remedies have been exhausted, or have lapsed, and that is not being paid in a timely manner pursuant to an agreement with the authority responsible for collecting the tax liability.

* * * * *

TRADE RESTRICTION CERTIFICATION

By submission of an offer, the Offeror certifies that with respect to this solicitation and any resultant contract, the Offeror -

- a. is not owned or controlled by one or more citizens of a foreign country included in the list of countries that discriminate against U.S. firms as published by the Office of the United States Trade Representative (U.S.T.R.);
- b. has not knowingly entered into any contract or subcontract for this project with a person that is a citizen or national of a foreign country included on the list of countries that discriminate against U.S. firms as published by the U.S.T.R; and
- c. has not entered into any subcontract for any product to be used on the Federal on the project that is produced in a foreign country included on the list of countries that discriminate against U.S. firms published by the U.S.T.R.

This certification concerns a matter within the jurisdiction of an agency of the United States of America and the making of a false, fictitious, or fraudulent certification may render the maker subject to prosecution under Title 18, United States Code, Section 1001.

The Offeror/Contractor must provide immediate written notice to the Owner if the Offeror/Contractor learns that its certification or that of a subcontractor was erroneous when submitted or has become erroneous by reason of changed circumstances. The Contractor must require subcontractors provide

immediate written notice to the Contractor if at any time it learns that its certification was erroneous by reason of changed circumstances.

Unless the restrictions of this clause are waived by the Secretary of Transportation in accordance with 49 CFR 30.17, no contract shall be awarded to an Offeror or subcontractor:

- (1) who is owned or controlled by one or more citizens or nationals of a foreign country included on the list of countries that discriminate against U.S. firms published by the U.S.T.R. or
- (2) whose subcontractors are owned or controlled by one or more citizens or nationals of a foreign country on such U.S.T.R. list or
- (3) who incorporates in the public works project any product of a foreign country on such U.S.T.R. list;

Nothing contained in the foregoing shall be construed to require establishment of a system of records in order to render, in good faith, the certification required by this provision. The knowledge and information of a contractor is not required to exceed that which is normally possessed by a prudent person in the ordinary course of business dealings.

The Offeror agrees that, if awarded a contract resulting from this solicitation, it will incorporate this provision for certification without modification in in all lower tier subcontracts. The contractor may rely on the certification of a prospective subcontractor that it is not a firm from a foreign country included on the list of countries that discriminate against U.S. firms as published by U.S.T.R, unless the Offeror has knowledge that the certification is erroneous.

This certification is a material representation of fact upon which reliance was placed when making an award. If it is later determined that the Contractor or subcontractor knowingly rendered an erroneous certification, the Federal Aviation Administration may direct through the Owner cancellation of the contract or subcontract for default at no cost to the Owner or the FAA.

Printed Name & Title: Joshua Abler, Inside Sales Manager MB

Signature: 

Date: 7/29/2024

(These certifications must be completed and submitted with the Bid)

EXHIBIT D: CERTIFICATION FOR RECEIPT OF ADDENDA

Receipt of the following Addenda is acknowledged:

ADDENDUM NO.: 1 DATED: 7/29/2024
ADDENDUM NO.: _____ DATED: _____
ADDENDUM NO.: _____ DATED: _____

M-B Companies, Inc.
(Firm or Corporation Making Bid)

(Signature of Authorized Person) Joshua Abler

P.O. Address: 1615 Wisconsin Avenue, New Holstein, WI 53061

Dated: 7/29/2024

(This form must be completed and submitted with the Bid)

EXHIBIT D: IRANIAN ENERGY SECTOR DIVESTMENT STATEMENT

1. Contractor/Proposer hereby represents that said Contractor/Proposer is in compliance with New York State General Municipal Law Section 103-g entitled "Iranian Energy Sector Divestment", in that said Contractor/Proposer has not:
 - (a) Provided goods or services of \$20 Million or more in the energy sector of Iran including but not limited to the provision of oil or liquefied natural gas tankers or products used to construct or maintain pipelines used to transport oil or liquefied natural gas for the energy sector of Iran; or
 - (b) Acted as a financial institution and extended \$20 Million or more in credit to another person for forty-five days or more, if that person's intent was to use the credit to provide goods or services in the energy sector in Iran.
2. Any Contractor/Proposer who has undertaken any of the above and is identified on a list created pursuant to Section 165-a (3)(b) of the New York State Finance Law as a person engaging in investment activities in Iran, shall not be deemed a responsible bidder pursuant to Section 103 of the New York State General Municipal Law.
3. Except as otherwise specifically provided herein, every Contractor/Proposer submitting a bid/proposal in response to this Request for Bids/Request for Proposals must certify and affirm the following under penalties of perjury:
 - (a) "By submission of this bid, each bidder and each person signing on behalf of any bidder certifies, and in the case of a joint bid, each party thereto certifies as to its own organization, under penalty of perjury, that to the best of its knowledge and belief, that each bidder is not on the list created pursuant to NYS Finance Law Section 165-a (3)(b)."
4. Except as otherwise specifically provided herein, any Bid/Proposal that is submitted without having complied with subdivision (a) above, shall not be considered for award. In any case where the Bidder/Proposer cannot make the certification as set forth in subdivision (a) above, the Bidder/Proposer shall so state and shall furnish with the bid a signed statement setting forth in detail the reasons therefore. The Owner reserves its rights, in accordance with General Municipal Law Section 103-g to award the Bid/Proposal to any Bidder/Proposer who cannot make the certification, on a case-by-case basis under the following circumstances:
 - (1) The investment activities in Iran were made before April 12, 2012, the investment activities in Iran have not been expanded or renewed after April 12, 2012, and the Bidder/Proposer has adopted, publicized and is implementing a formal plan to cease the investment activities in Iran and to refrain from engaging in any new investments in Iran; or

(2) The Owner has made a determination that the goods or services are necessary for the Owner to perform its functions and that, absent such an exemption, the Owner would be unable to obtain the goods or services for which the Bid/Proposal is offered. Such determination shall be made by the Owner in writing and shall be a public document.

5. **Bidder or Proposer shall sign and notarize the attached “Certification of Compliance with the Iran Divestment Act” form with your proposal.**

EXHIBIT D: CERTIFICATION OF COMPLIANCE WITH THE IRAN DIVESTMENT ACT

As a result of the Iran Divestment Act of 2012 (the "Act"), Chapter 1 of the 2012 Laws of New York, a new provision has been added to State Finance Law (SFL) § 165-a and New York General Municipal Law § 103-g, both effective April 12, 2012. Under the Act, the Commissioner of the Office of General Services (OGS) will be developing a list of "persons" who are engaged in "investment activities in Iran" (both are defined terms in the law) (the "Prohibited Entities List"). Pursuant to SFL § 165-a(3)(b), the initial list is expected to be issued no later than 120 days after the Act's effective date at which time it will be posted on the OGS website.

By submitting a bid in response to this solicitation or by assuming the responsibility of a Contract awarded hereunder, each Bidder/Contractor, any person signing on behalf of any Bidder/Contractor and any assignee or subcontractor and, in the case of a joint bid, each party thereto, certifies, under penalty of perjury, that once the Prohibited Entities List is posted on the OGS website, that to the best of its knowledge and belief, that each Bidder/Contractor and any subcontractor or assignee is not identified on the Prohibited Entities List created pursuant to SFL § 165-a(3)(b).

Additionally, Bidder/Contractor is advised that once the Prohibited Entities List is posted on the OGS Website, any Bidder/Contractor seeking to renew or extend a Contract or assume the responsibility of a Contract awarded in response to this solicitation must certify at the time the Contract is renewed, extended or assigned that it is not included on the Prohibited Entities List.

During the term of the Contract, should the Owner receive information that a Bidder/Contractor is in violation of the above-referenced certification, the Owner will offer the person or entity an opportunity to respond. If the person or entity fails to demonstrate that he/she/it has ceased engagement in the investment which is in violation of the Act within 90 days after the determination of such violation, then the Owner shall take such action as may be appropriate including, but not limited to, imposing sanctions, seeking compliance, recovering damages or declaring the Bidder/Contractor in default.

The Owner reserves the right to reject any bid or request for assignment for a Bidder/Contractor that appears on the Prohibited Entities List prior to the award of a contract and to pursue a responsibility review with respect to any Bidder/Contractor that is awarded a contract and subsequently appears on the Prohibited Entities List.

I, Joshua Abler, being duly sworn, deposes and says

that he/she is the Assistant Secretary of the M-B Companies, Inc. Corporation and that neither the Bidder/Contractor nor any proposed subcontractor is identified on the

Prohibited Entities List.



Joshua Abler SIGNED

SWORN to before me this

____ 29th ____ day of ____ July _____, 20 24

Notary Public: 

William M. Hecker



(This form must be completed and submitted with the Bid)

EXHIBIT D: OPERATIONAL STANDARDS AND COMPLIANCE TESTING.

1. As part of the bid package, a complete description of the carrier vehicle and snow blower, including make, model, weight, size, capabilities, warranty, etc., shall be included. A manufacturer's specification sheet of the equipment being bid must be included in the bid documents.
2. The manufacturer is responsible for conducting tests to ensure that its snow removal and ice control equipment meets the operational and performance requirements it advertises. The manufacturer must submit certified records of these compliance tests with each response to an invitation to bid. Equipment tests must be conducted on standard production models and not on specially constructed prototypes. Refer to AC 150/5220-20A (or current version) for required tests. The bidder shall supply results of performance testing for the model proposed in accordance with SAE ARP5539, Appendix A. Including: Snow field test and constructed windrow test.

EXHIBIT E:

**New York State Department of Transportation (NYSDOT) Standard Clauses
for New York State Contracts.**

The following verbiage is included verbatim from Appendix A, Standard Clauses for New York State Contracts, dated January 2014 as required by New York State Department of Transportation grant assurances:

STANDARD CLAUSES FOR NYS CONTRACTS

The parties to the attached contract, license, lease, amendment or other agreement of any kind (hereinafter, "the contract" or "this contract") agree to be bound by the following clauses which are hereby made a part of the contract (the word "Contractor" herein refers to any party other than the State, whether a contractor, licensor, licensee, lessor, lessee or any other party):

1. **EXECUTORY CLAUSE.** In accordance with Section 41 of the State Finance Law, the State shall have no liability under this contract to the Contractor or to anyone else beyond funds appropriated and available for this contract.
2. **NON-ASSIGNMENT CLAUSE.** In accordance with Section 138 of the State Finance Law, this contract may not be assigned by the Contractor or its right, title or interest therein assigned, transferred, conveyed, sublet or otherwise disposed of without the State's previous written consent, and attempts to do so are null and void. Notwithstanding the foregoing, such prior written consent of an assignment of a contract let pursuant to Article XI of the State Finance Law may be waived at the discretion of the contracting agency and with the concurrence of the State Comptroller where the original contract was subject to the State Comptroller's approval, where the assignment is due to a reorganization, merger or consolidation of the Contractor's business entity or enterprise. The State retains its right to approve an assignment and to require that any Contractor demonstrate its responsibility to do business with the State. The Contractor may, however, assign its right to receive payments without the State's prior written consent unless this contract concerns Certificates of Participation pursuant to Article 5-A of the State Finance Law.
3. **COMPTROLLER'S APPROVAL.** In accordance with Section 112 of the State Finance Law (or, if this contract is with the State University or City University of New York, Section 355 or Section 6218 of the Education Law), if this contract exceeds \$50,000 (or the minimum thresholds agreed to by the Office of the State Comptroller for certain S.U.N.Y. and C.U.N.Y. contracts), or if this is an amendment for any amount to a contract which, as so amended, exceeds said statutory amount, or if, by this contract, the

State agrees to give something other than money when the value or reasonably estimated value of such consideration exceeds \$10,000, it shall not be valid, effective or binding upon the State until it has been approved by the State Comptroller and filed in his office. Comptroller's approval of contracts let by the Office of General Services is required when such contracts exceed \$85,000 (State Finance Law Section 163.6-a). However, such pre-approval shall not be required for any contract established as a centralized contract through the Office of General Services or for a purchase order or other transaction issued under such centralized contract.

4. **WORKERS' COMPENSATION BENEFITS.** In accordance with Section 142 of the State Finance Law, this contract shall be void and of no force and effect unless the Contractor shall provide and maintain coverage during the life of this contract for the benefit of such employees as are required to be covered by the provisions of the Workers' Compensation Law.
5. **NON-DISCRIMINATION REQUIREMENTS.** To the extent required by Article 15 of the Executive Law (also known as the Human Rights Law) and all other State and Federal statutory and constitutional non-discrimination provisions, the Contractor will not discriminate against any employee or applicant for employment because of race, creed, color, sex (including gender identity or expression), national origin, sexual orientation, military status, age, disability, predisposing genetic characteristics, marital status or domestic violence victim status. Furthermore, in accordance with Section 220-e of the Labor Law, if this is a contract for the construction, alteration or repair of any public building or public work or for the manufacture, sale or distribution of materials, equipment or supplies, and to the extent that this contract shall be performed within the State of New York, Contractor agrees that neither it nor its subcontractors shall, by reason of race, creed, color, disability, sex, or national origin: (a) discriminate in hiring against any New York State citizen who is qualified and available to perform the work; or (b) discriminate against or intimidate any employee hired for the performance of work under this contract. If this is a building service contract as defined in Section 230 of the Labor Law, then, in accordance with Section 239 thereof, Contractor agrees that neither it nor its subcontractors shall by reason of race, creed, color, national origin, age, sex or disability: (a) discriminate in hiring against any New York State citizen who is qualified and available to perform the work; or (b) discriminate against or intimidate any employee hired for the performance of work under this contract. Contractor is subject to fines of \$50.00 per person per day for any violation of Section 220-e or Section 239 as well as possible termination of this contract and forfeiture of all moneys due hereunder for a second or subsequent violation.
6. **WAGE AND HOURS PROVISIONS.** If this is a public work contract covered by Article 8 of the Labor Law or a building service contract covered by Article 9 thereof, neither Contractor's employees nor the employees of its subcontractors may be required or permitted to work more than the number of hours or days stated in said statutes, except

as otherwise provided in the Labor Law and as set forth in prevailing wage and supplement schedules issued by the State Labor Department. Furthermore, Contractor and its subcontractors must pay at least the prevailing wage rate and pay or provide the prevailing supplements, including the premium rates for overtime pay, as determined by the State Labor Department in accordance with the Labor Law. Additionally, effective April 28, 2008, if this is a public work contract covered by Article 8 of the Labor Law, the Contractor understands and agrees that the filing of payrolls in a manner consistent with Subdivision 3-a of Section 220 of the Labor Law shall be a condition precedent to payment by the State of any State approved sums due and owing for work done upon the project. **SEE "SPECIAL NOTE" REGARDING PREVAILING WAGE RATES FOLLOWING THIS SECTION.**

7. **NON-COLLUSIVE BIDDING CERTIFICATION.** In accordance with Section 139-d of the State Finance Law, if this contract was awarded based upon the submission of bids, Contractor affirms, under penalty of perjury, that its bid was arrived at independently and without collusion aimed at restricting competition. Contractor further affirms that, at the time Contractor submitted its bid, an authorized and responsible person executed and delivered to the State a non-collusive bidding certification on Contractor's behalf.
8. **INTERNATIONAL BOYCOTT PROHIBITION.** In accordance with Section 220-f of the Labor Law and Section 139-h of the State Finance Law, if this contract exceeds \$5,000, the Contractor agrees, as a material condition of the contract, that neither the Contractor nor any substantially owned or affiliated person, firm, partnership or corporation has participated, is participating, or shall participate in an international boycott in violation of the federal Export Administration Act of 1979 (50 USC App. Sections 2401 et seq.) or regulations thereunder. If such Contractor, or any of the aforesaid affiliates of Contractor, is convicted or is otherwise found to have violated said laws or regulations upon the final determination of the United States Commerce Department or any other appropriate agency of the United States subsequent to the contract's execution, such contract, amendment or modification thereto shall be rendered forfeit and void. The Contractor shall so notify the State Comptroller within five (5) business days of such conviction, determination or disposition of appeal (2NYCRR 105.4).
9. **SET-OFF RIGHTS.** The State shall have all of its common law, equitable and statutory rights of set-off. These rights shall include, but not be limited to, the State's option to withhold for the purposes of set-off any moneys due to the Contractor under this contract up to any amounts due and owing to the State with regard to this contract, any other contract with any State department or agency, including any contract for a term commencing prior to the term of this contract, plus any amounts due and owing to the State for any other reason including, without limitation, tax delinquencies, fee delinquencies or monetary penalties relative thereto. The State shall exercise its set-off rights in accordance with normal State practices including, in cases of set-off pursuant to

an audit, the finalization of such audit by the State agency, its representatives, or the State Comptroller.

10. RECORDS. The Contractor shall establish and maintain complete and accurate books, records, documents, accounts and other evidence directly pertinent to performance under this contract (hereinafter, collectively, "the Records"). The Records must be kept for the balance of the calendar year in which they were made and for six (6) additional years thereafter. The State Comptroller, the Attorney General and any other person or entity authorized to conduct an examination, as well as the agency or agencies involved in this contract, shall have access to the Records during normal business hours at an office of the Contractor within the State of New York or, if no such office is available, at a mutually agreeable and reasonable venue within the State, for the term specified above for the purposes of inspection, auditing and copying. The State shall take reasonable steps to protect from public disclosure any of the Records which are exempt from disclosure under Section 87 of the Public Officers Law (the "Statute") provided that: (i) the Contractor shall timely inform an appropriate State official, in writing, that said records should not be disclosed; and (ii) said records shall be sufficiently identified; and (iii) designation of said records as exempt under the Statute is reasonable. Nothing contained herein shall diminish, or in any way adversely affect, the State's right to discovery in any pending or future litigation.

11. IDENTIFYING INFORMATION AND PRIVACY NOTIFICATION.

a) Identification Number(s). Every invoice or New York State Claim for Payment submitted to a New York State agency by a payee, for payment for the sale of goods or services or for transactions (e.g., leases, easements, licenses, etc.) related to real or personal property must include the payee's identification number. The number is any or all of the following:

(i) the payee's Federal employer identification number,

(ii) the payee's Federal social security number, and/or

(iii) the payee's Vendor Identification Number assigned by the Statewide Financial System.

Failure to include such number or numbers may delay payment. Where the payee does not have such number or numbers, the payee, on its invoice or Claim for Payment, must give the reason or reasons why the payee does not have such number or numbers.

(b) Privacy Notification.

(1) The authority to request the above personal information from a seller of goods or services or a lessor of real or personal property, and the authority to maintain such

information, is found in Section 5 of the State Tax Law. Disclosure of this information by the seller or lessor to the State is mandatory. The principal purpose for which the information is collected is to enable the State to identify individuals, businesses and others who have been delinquent in filing tax returns or may have understated their tax liabilities and to generally identify persons affected by the taxes administered by the Commissioner of Taxation and Finance. The information will be used for tax administration purposes and for any other purpose authorized by law.

- (2) The personal information is requested by the purchasing unit of the agency contracting to purchase the goods or services or lease the real or personal property covered by this contract or lease. The information is maintained in the Statewide Financial System by the Vendor Management Unit within the Bureau of State Expenditures, Office of the State Comptroller, 110 State Street, Albany, New York 12236.

12. EQUAL EMPLOYMENT OPPORTUNITIES FOR MINORITIES AND WOMEN.

In accordance with Section 312 of the Executive Law and 5 NYCRR 143, if this contract is: (i) a written agreement or purchase order instrument, providing for a total expenditure in excess of \$25,000.00, whereby a contracting agency is committed to expend or does expend funds in return for labor, services, supplies, equipment, materials or any combination of the foregoing, to be performed for, or rendered or furnished to the contracting agency; or (ii) a written agreement in excess of \$100,000.00 whereby a contracting agency is committed to expend or does expend funds for the acquisition, construction, demolition, replacement, major repair or renovation of real property and improvements thereon; or (iii) a written agreement in excess of \$100,000.00 whereby the owner of a State assisted housing project is committed to expend or does expend funds for the acquisition, construction, demolition, replacement, major repair or renovation of real property and improvements thereon for such project, then the following shall apply and by signing this agreement the Contractor certifies and affirms that it is Contractor's equal employment opportunity policy that:

- (a) The Contractor will not discriminate against employees or applicants for employment because of race, creed, color, national origin, sex, age, disability or marital status, shall make and document its conscientious and active efforts to employ and utilize minority group members and women in its work force on State contracts and will undertake or continue existing programs of affirmative action to ensure that minority group members and women are afforded equal employment opportunities without discrimination. Affirmative action shall mean recruitment, employment, job assignment, promotion, upgradings, demotion, transfer, layoff, or termination and rates of pay or other forms of compensation;
- (b) at the request of the contracting agency, the Contractor shall request each employment agency, labor union, or authorized representative of workers with which

it has a collective bargaining or other agreement or understanding, to furnish a written statement that such employment agency, labor union or representative will not discriminate on the basis of race, creed, color, national origin, sex, age, disability or marital status and that such union or representative will affirmatively cooperate in the implementation of the Contractor's obligations herein; and

- (c) the Contractor shall state, in all solicitations or advertisements for employees, that, in the performance of the State contract, all qualified applicants will be afforded equal employment opportunities without discrimination because of race, creed, color, national origin, sex, age, disability or marital status.

Contractor will include the provisions of "a", "b", and "c" above, in every subcontract over \$25,000.00 for the construction, demolition, replacement, major repair, renovation, planning or design of real property and improvements thereon (the "Work") except where the Work is for the beneficial use of the Contractor. Section 312 does not apply to: (i) work, goods or services unrelated to this contract; or (ii) employment outside New York State. The State shall consider compliance by a contractor or subcontractor with the requirements of any federal law concerning equal employment opportunity which effectuates the purpose of this section. The contracting agency shall determine whether the imposition of the requirements of the provisions hereof duplicate or conflict with any such federal law and if such duplication or conflict exists, the contracting agency shall waive the applicability of Section 312 to the extent of such duplication or conflict. Contractor will comply with all duly promulgated and lawful rules and regulations of the Department of Economic Development's Division of Minority and Women's Business Development pertaining hereto.

- 13. **CONFLICTING TERMS.** In the event of a conflict between the terms of the contract (including any and all attachments thereto and amendments thereof) and the terms of this Appendix A, the terms of this Appendix A shall control.
- 14. **GOVERNING LAW.** This contract shall be governed by the laws of the State of New York except where the Federal supremacy clause requires otherwise.
- 15. **LATE PAYMENT.** Timeliness of payment and any interest to be paid to Contractor for late payment shall be governed by Article 11-A of the State Finance Law to the extent required by law.
- 16. **NO ARBITRATION.** Disputes involving this contract, including the breach or alleged breach thereof, may not be submitted to binding arbitration (except where statutorily authorized), but must, instead, be heard in a court of competent jurisdiction of the State of New York.

17. **SERVICE OF PROCESS.** In addition to the methods of service allowed by the State Civil Practice Law & Rules ("CPLR"), Contractor hereby consents to service of process upon it by registered or certified mail, return receipt requested. Service hereunder shall be complete upon Contractor's actual receipt of process or upon the State's receipt of the return thereof by the United States Postal Service as refused or undeliverable. Contractor must promptly notify the State, in writing, of each and every change of address to which service of process can be made. Service by the State to the last known address shall be sufficient. Contractor will have thirty (30) calendar days after service hereunder is complete in which to respond.
18. **PROHIBITION ON PURCHASE OF TROPICAL HARDWOODS.** The Contractor certifies and warrants that all wood products to be used under this contract award will be in accordance with, but not limited to, the specifications and provisions of Section 165 of the State Finance Law, (Use of Tropical Hardwoods) which prohibits purchase and use of tropical hardwoods, unless specifically exempted, by the State or any governmental agency or political subdivision or public benefit corporation. Qualification for an exemption under this law will be the responsibility of the contractor to establish to meet with the approval of the State.

In addition, when any portion of this contract involving the use of woods, whether supply or installation, is to be performed by any subcontractor, the prime Contractor will indicate and certify in the submitted bid proposal that the subcontractor has been informed and is in compliance with specifications and provisions regarding use of tropical hardwoods as detailed in §165 State Finance Law. Any such use must meet with the approval of the State; otherwise, the bid may not be considered responsive. Under bidder certifications, proof of qualification for exemption will be the responsibility of the Contractor to meet with the approval of the State.

19. **MACBRIDE FAIR EMPLOYMENT PRINCIPLES.** In accordance with the MacBride Fair Employment Principles (Chapter 807 of the Laws of 1992), the Contractor hereby stipulates that the Contractor either (a) has no business operations in Northern Ireland, or (b) shall take lawful steps in good faith to conduct any business operations in Northern Ireland in accordance with the MacBride Fair Employment Principles (as described in Section 165 of the New York State Finance Law), and shall permit independent monitoring of compliance with such principles.
20. **OMNIBUS PROCUREMENT ACT OF 1992.** It is the policy of New York State to maximize opportunities for the participation of New York State business enterprises, including minority and women-owned business enterprises as bidders, subcontractors and suppliers on its procurement contracts.

Information on the availability of New York State subcontractors and suppliers is available from:

NYS Department of Economic Development
Division for Small Business
Albany, New York 12245
Telephone: 518-292-5100
Fax: 518-292-5884
email: opa@esd.ny.gov

A directory of certified minority and women-owned business enterprises is available from:

NYS Department of Economic Development
Division of Minority and Women's Business Development
633 Third Avenue
New York, NY 10017
212-803-2414
email: mwbecertification@esd.ny.gov
<https://ny.newnycontracts.com/FrontEnd/VendorSearchPublic.asp>

The Omnibus Procurement Act of 1992 requires that by signing this bid proposal or contract, as applicable, Contractors certify that whenever the total bid amount is greater than \$1 million:

- (a) The Contractor has made reasonable efforts to encourage the participation of New York State Business Enterprises as suppliers and subcontractors, including certified minority and women-owned business enterprises, on this project, and has retained the documentation of these efforts to be provided upon request to the State;
- (b) The Contractor has complied with the Federal Equal Opportunity Act of 1972 (P.L. 92-261), as amended;
- (c) The Contractor agrees to make reasonable efforts to provide notification to New York State residents of employment opportunities on this project through listing any such positions with the Job Service Division of the New York State Department of Labor, or providing such notification in such manner as is consistent with existing collective bargaining contracts or agreements. The Contractor agrees to document these efforts and to provide said documentation to the State upon request; and
- (d) The Contractor acknowledges notice that the State may seek to obtain offset credits from foreign countries as a result of this contract and agrees to cooperate with the State in these efforts.

21. **RECIPROCITY AND SANCTIONS PROVISIONS.** Bidders are hereby notified that if their principal place of business is located in a country, nation, province, state or political subdivision that penalizes New York State vendors, and if the goods or services they offer will be substantially produced or performed outside New York State, the Omnibus Procurement Act 1994 and 2000 amendments (Chapter 684 and Chapter 383, respectively) require that they be denied contracts which they would otherwise obtain. NOTE: As of May 15, 2002, the list of discriminatory jurisdictions subject to this provision includes the states of South Carolina, Alaska, West Virginia, Wyoming, Louisiana and Hawaii. Contact NYS Department of Economic Development for a current list of jurisdictions subject to this provision.
22. **COMPLIANCE WITH NEW YORK STATE INFORMATION SECURITY BREACH AND NOTIFICATION ACT.** Contractor shall comply with the provisions of the New York State Information Security Breach and Notification Act (General Business Law Section 899-aa; State Technology Law Section 208).
23. **COMPLIANCE WITH CONSULTANT DISCLOSURE LAW.** If this is a contract for consulting services, defined for purposes of this requirement to include analysis, evaluation, research, training, data processing, computer programming, engineering, environmental, health, and mental health services, accounting, auditing, paralegal, legal or similar services, then, in accordance with Section 163 (4-g) of the State Finance Law (as amended by Chapter 10 of the Laws of 2006), the Contractor shall timely, accurately and properly comply with the requirement to submit an annual employment report for the contract to the agency that awarded the contract, the Department of Civil Service and the State Comptroller.
24. **PROCUREMENT LOBBYING.** To the extent this agreement is a "procurement contract" as defined by State Finance Law Sections 139-j and 139-k, by signing this agreement the contractor certifies and affirms that all disclosures made in accordance with State Finance Law Sections 139-j and 139-k are complete, true and accurate. In the event such certification is found to be intentionally false or intentionally incomplete, the State may terminate the agreement by providing written notification to the Contractor in accordance with the terms of the agreement.
25. **CERTIFICATION OF REGISTRATION TO COLLECT SALES AND COMPENSATING USE TAX BY CERTAIN STATE CONTRACTORS, AFFILIATES AND SUBCONTRACTORS.**
To the extent this agreement is a contract as defined by Tax Law Section 5-a, if the contractor fails to make the certification required by Tax Law Section 5-a or if during the term of the contract, the Department of Taxation and Finance or the covered agency, as defined by Tax Law 5-a, discovers that the certification, made under penalty of perjury, is false, then such failure to file or false certification shall be a material breach of this contract and this contract may be terminated, by providing written notification to the

Contractor in accordance with the terms of the agreement, if the covered agency determines that such action is in the best interest of the State.

26. **IRAN DIVESTMENT ACT.** By entering into this Agreement, Contractor certifies in accordance with State Finance Law §165-a that it is not on the “Entities Determined to be Non-Responsive Bidders/Offerers pursuant to the New York State Iran Divestment Act of 2012” (“Prohibited Entities List”) posted at:
<http://www.ogs.ny.gov/about/regs/docs/ListofEntities.pdf>

Contractor further certifies that it will not utilize on this Contract any subcontractor that is identified on the Prohibited Entities List. Contractor agrees that should it seek to renew or extend this Contract, it must provide the same certification at the time the Contract is renewed or extended. Contractor also agrees that any proposed Assignee of this Contract will be required to certify that it is not on the Prohibited Entities List before the contract assignment will be approved by the State.

During the term of the Contract, should the state agency receive information that a person (as defined in State Finance Law §165-a) is in violation of the above-referenced certifications, the state agency will review such information and offer the person an opportunity to respond. If the person fails to demonstrate that it has ceased its engagement in the investment activity which is in violation of the Act within 90 days after the determination of such violation, then the state agency shall take such action as may be appropriate and provided for by law, rule, or contract, including, but not limited to, imposing sanctions, seeking compliance, recovering damages, or declaring the Contractor in default.

The state agency reserves the right to reject any bid, request for assignment, renewal or extension for an entity that appears on the Prohibited Entities List prior to the award, assignment, renewal or extension of a contract, and to pursue a responsibility review with respect to any entity that is awarded a contract and appears on the Prohibited Entities list after contract award.

NYS DOT Terms and Conditions.

The following verbiage is included verbatim as required by a New York State Department of Transportation grant assurance:

TERMS AND CONDITIONS (ADDENDUM NO. 1):

1. The Grantee agrees to incorporate or cause to be incorporated into any contract for construction work, or furnishing of any materials, supplies, or equipment or professional consulting services of any kind in connection with the Project, clauses under which the Contractor:

- a. Agrees to procure and maintain insurance of the kinds and in the amounts specified.
- b. Agrees that he will comply with the requirements of the State Labor Law and particularly Sections 220 and 220-4 thereof as amended, and as set forth in Appendix A hereof.
- c. Agrees that during the performance of this contract, the Contractor will not discriminate against any employee or applicant for employment because of race, creed, sex, color or national origin and will comply with the Non-Discrimination provisions set forth in Appendix A hereof.
- d. Agrees that he will cause all persons employed upon the work including his subcontractors, agents, officers and employees, to comply with all applicable laws in the jurisdiction in which the work is performed.
- e. Agrees not to assign, transfer, convey, sublet or otherwise dispose of this agreement or any part thereof, or of its right, title or interest therein or its power to execute such agreement to any person, company or corporation without the previous consent in writing of the Grantee and the Commissioner of Transportation.
- f. Agrees that in accordance with its status as an independent contractor, it will conduct itself with such status that it will neither hold itself out as nor claim to be an officer or employee of the State by reason hereof, and that it will not by reason hereof, make any claim demand of application to or for any right or privilege applicable to an officer or employee of the State, including, but not limited to, Workmen's Compensation coverage, Unemployment Insurance Benefits, Social Security coverage or Retirement membership or Credit.
- g. Agrees that this agreement may be canceled or terminated by the Grantee if any work under this agreement is in conflict with the provisions of Section 74 of the Public Officers Law.
- h. Agrees that any patentable result arising out of this Agreement, as well as all information, designs, specification, know-how, data, and findings, shall be made available without cost to the State or its licenses for public use.
- i. Agrees that for construction work he will furnish a performance bond in an amount at least equal to 100 percent of this contract price as security for the faithful performance of his contract and also a labor and material bond in an amount equal to 100 percent of his contract price as security for the payment of all persons performing labor on the project under his contract and

furnishing materials in connection with his contract. The performance bond and the labor and material bond may be in one or in separate instruments in accordance with law.

- j. Agrees that the Commissioner and the State Comptroller reserve the right to audit and inspect the work of the contractor and any and all records thereof through representatives of the State, as well as through officers and employees of the State, as they shall determine.
 - k. Agrees that the State shall not be obligated or liable hereunder to any party other than the Grantee.
 - l. Agrees that if any provision of this Agreement is held invalid, the remainder of this Agreement shall not be affected thereby if such remainder would then continue to conform to the terms and requirements of the applicable law.
 - m. Agrees that by execution of the Agreement the Contractor represents that it has not paid and, also, agrees not to pay, any bonus or commission for the purpose of obtaining an approval of this agreement.
 - n. Agrees that all project documents requiring formal approval by a Federal Agency will be submitted to the Commissioner for his prior approval and forwarding to the Federal Agency for its formal approval.
2. The Grantee agrees to give full opportunity for free, open and competitive bidding for each contract to be let by it calling for construction or the furnishing of any materials, supplies, or equipment to be paid for with Project funds in accordance with the requirements of Section 103 of the General Municipal Law, the State Finance Law and any other applicable State Laws, Regulations or any requirements or opinions of the State comptroller.
3. The Grantee agrees that contracts for professional or consulting services may be negotiated, but they must be in writing and must state the maximum compensation or reimbursement to be paid. Negotiations must be adequately documented to show consultants considered, proposals received, reasons for selecting the proposed consultant, and the unit basis or other detailed explanation in support of the amount of compensation to be paid.

EXHIBIT F:

Federal Contract Provision Guidelines for Obligated Sponsors and Airport Improvement Program (AIP) Projects

The Contractor is required to insert these contract provision in each lower tier contract (e.g. subcontract or sub-agreement).

The Contractor is required (including all subcontractors) to incorporate these contract provisions by reference for work done under any purchase orders, rental agreements and other agreements for supplies or services.

The Contractor shall be responsible for compliance with these contract provisions by any subcontractor, lower-tier subcontractor or service provider.

A1 ACCESS TO RECORDS AND REPORTS

The Contractor must maintain an acceptable cost accounting system. The Contractor agrees to provide the Owner, the Federal Aviation Administration and the Comptroller General of the United States or any of their duly authorized representatives access to any books, documents, papers and records of the Contractor which are directly pertinent to the specific contract for the purpose of making audit, examination, excerpts and transcriptions. The Contractor agrees to maintain all books, records and reports required under this contract for a period of not less than three years after final payment is made and all pending matters are closed.

A2 AFFIRMATIVE ACTION REQUIREMENT (Section not applicable.)

A3 BREACH OF CONTRACT TERMS

Any violation or breach of terms of this contract on the part of the Contractor or its subcontractors may result in the suspension or termination of this contract or such other action that may be necessary to enforce the rights of the parties of this agreement.

Owner will provide Contractor written notice that describes the nature of the breach and corrective actions the Contractor must undertake in order to avoid termination of the contract. Owner reserves the right to withhold payments to Contractor until such time the Contractor corrects the breach or the Owner elects to terminate the contract. The Owner's notice will identify a specific date by which the Contractor must correct the breach. Owner may proceed with termination of the contract if the Contractor fails to correct the breach by the deadline indicated in the Owner's notice.

The duties and obligations imposed by the Contract Documents and the rights and remedies available thereunder are in addition to, and not a limitation of, any duties, obligations, rights and remedies otherwise imposed or available by law.

A4 BUY AMERICAN PREFERENCE

The Contractor agrees to comply with 49 USC § 50101, which provides that Federal funds may not be obligated unless all steel and manufactured goods used in AIP funded projects are produced in the United States, unless the Federal Aviation Administration has issued a waiver for the product; the product is listed as an Excepted Article, Material Or Supply in Federal Acquisition Regulation subpart 25.108; or is included in the FAA Nationwide Buy American Waivers Issued list.

A bidder or offeror must complete and submit the Buy America certification included herein with their bid or offer. The Owner will reject as nonresponsive any bid or offer that does not include a completed Certificate of Buy American Compliance.

Certificate of Buy American Compliance –Total facility & Manufactured Product

NOTE: Certification is included in the PROPOSAL.

A5 CIVIL RIGHTS – GENERAL CIVIL RIGHTS PROVISIONS

The Contractor agrees to comply with pertinent statutes, Executive Orders and such rules as are promulgated to ensure that no person shall, on the grounds of race, creed, color, national origin, sex, age, or disability be excluded from participating in any activity conducted with or benefiting from Federal assistance.

This provision binds the Contractor and subcontractors from the bid solicitation period through the completion of the contract. This provision is in addition to that required by Title VI of the Civil Rights Act of 1964.

A6 CIVIL RIGHTS – TITLE VI ASSURANCE

Title VI Solicitation Notice:

The Sponsor, in accordance with the provisions of Title VI of the Civil Rights Act of 1964 (78 Stat. 252, 42 USC §§ 2000d to 2000d-4) and the Regulations, hereby notifies all bidders or offerors that it will affirmatively ensure that any contract entered into pursuant to this advertisement, select disadvantaged business enterprises will be afforded full and fair opportunity to submit bids in response to this invitation and will not be discriminated against on the grounds of race, color, or national origin in consideration for an award.

Compliance with Nondiscrimination Requirements:

During the performance of this contract, the Contractor, for itself, its assignees, and successors in interest (hereinafter referred to as the “Contractor”), agrees as follows:

1. Compliance with Regulations: The Contractor (hereinafter includes consultants) will comply with the Title VI List of Pertinent Nondiscrimination Acts and Authorities, as they may be amended from time to time, which are herein incorporated by reference and made a part of this contract.

2. Nondiscrimination: The Contractor, with regard to the work performed by it during the contract, will not discriminate on the grounds of race, color, or national origin in the selection and retention of subcontractors, including procurements of materials and leases of equipment. The Contractor will not participate directly or indirectly in the discrimination prohibited by the Nondiscrimination Acts and Authorities, including employment practices when the contract covers any activity, project, or program set forth in Appendix B of 49 CFR part 21.

3. Solicitations for Subcontracts, including Procurements of Materials and Equipment: In all solicitations, either by competitive bidding or negotiation made by the Contractor for work to be performed under a subcontract, including procurements of materials, or leases of equipment, each potential subcontractor or supplier will be notified by the Contractor of the contractor's obligations under this contract and the Nondiscrimination Acts and Authorities on the grounds of race, color, or national origin.

4. Information and Reports: The Contractor will provide all information and reports required by the Acts, the Regulations, and directives issued pursuant thereto and will permit access to its books, records, accounts, other sources of information, and its facilities as may be determined by the sponsor or the Federal Aviation Administration to be pertinent to ascertain compliance with such Nondiscrimination Acts and Authorities and instructions. Where any information required of a contractor is in the exclusive possession of another who fails or refuses to furnish the information, the Contractor will so certify to the sponsor or the Federal Aviation Administration, as appropriate, and will set forth what efforts it has made to obtain the information.

5. Sanctions for Noncompliance: In the event of a Contractor's noncompliance with the non-discrimination provisions of this contract, the sponsor will impose such contract sanctions as it or the Federal Aviation Administration may determine to be appropriate, including, but not limited to:

- a. Withholding payments to the Contractor under the contract until the Contractor complies; and/or
- b. Cancelling, terminating, or suspending a contract, in whole or in part.

6. Incorporation of Provisions: The Contractor will include the provisions of paragraphs one through six in every subcontract, including procurements of materials and leases of equipment, unless exempt by the Acts, the Regulations, and directives issued pursuant thereto. The Contractor will take action with respect to any subcontract or procurement as the sponsor or the Federal Aviation Administration may direct as a means of enforcing such provisions including sanctions for noncompliance. Provided, that if the Contractor becomes involved in, or is threatened with litigation by a subcontractor, or supplier because of such direction, the Contractor may request the sponsor to enter into any litigation to protect the interests of the sponsor. In addition, the Contractor may request the United States to enter into the litigation to protect the interests of the United States.

Title VI List of Pertinent Nondiscrimination Acts and Authorities

During the performance of this contract, the Contractor, for itself, its assignees, and successors in interest (hereinafter referred to as the "Contractor") agrees to comply with the following non-discrimination statutes and authorities; including but not limited to:

- Title VI of the Civil Rights Act of 1964 (42 USC § 2000d et seq., 78 stat. 252) (prohibits discrimination on the basis of race, color, national origin);
- 49 CFR part 21 (Non-discrimination in Federally-assisted programs of the Department of Transportation—Effectuation of Title VI of the Civil Rights Act of 1964);
- The Uniform Relocation Assistance and Real Property Acquisition Policies Act of 1970, (42 USC § 4601) (prohibits unfair treatment of persons displaced or whose property has been acquired because of Federal or Federal-aid programs and projects);
- Section 504 of the Rehabilitation Act of 1973 (29 USC § 794 et seq.), as amended (prohibits discrimination on the basis of disability); and 49 CFR part 27;
- The Age Discrimination Act of 1975, as amended (42 USC § 6101 et seq.) (prohibits discrimination on the basis of age);
- Airport and Airway Improvement Act of 1982 (49 USC § 471, Section 47123), as amended (prohibits discrimination based on race, creed, color, national origin, or sex);
- The Civil Rights Restoration Act of 1987 (PL 100-209) (broadened the scope, coverage and applicability of Title VI of the Civil Rights Act of 1964, the Age Discrimination Act of 1975 and Section 504 of the Rehabilitation Act of 1973, by expanding the definition of the terms “programs or activities” to include all of the programs or activities of the Federal-aid recipients, sub-recipients and contractors, whether such programs or activities are Federally funded or not);
- Titles II and III of the Americans with Disabilities Act of 1990, which prohibit discrimination on the basis of disability in the operation of public entities, public and private transportation systems, places of public accommodation, and certain testing entities (42 USC §§ 12131 – 12189) as implemented by U.S. Department of Transportation regulations at 49 CFR parts 37 and 38;
- The Federal Aviation Administration’s Nondiscrimination statute (49 USC § 47123) (prohibits discrimination on the basis of race, color, national origin, and sex);
- Executive Order 12898, Federal Actions to Address Environmental Justice in Minority Populations and Low-Income Populations, which ensures nondiscrimination against minority populations by discouraging programs, policies, and activities with disproportionately high and adverse human health or environmental effects on minority and low-income populations;
- Executive Order 13166, Improving Access to Services for Persons with Limited English Proficiency, and resulting agency guidance, national origin discrimination includes discrimination because of limited English proficiency (LEP). To ensure compliance with Title VI, you must take reasonable steps to ensure that LEP persons have meaningful access to your programs (70 Fed. Reg. at 74087 to 74100);
- Title IX of the Education Amendments of 1972, as amended, which prohibits you from discriminating because of sex in education programs or activities (20 USC 1681 et seq).

A7 CLEAN AIR AND WATER POLLUTION CONTROL

Contractor agrees to comply with all applicable standards, orders, and regulations issued pursuant to the Clean Air Act (42 USC § 740-7671q) and the Federal Water Pollution Control Act as amended (33 USC § 1251-1387). The Contractor agrees to report any violation to the Owner immediately upon discovery. The Owner assumes responsibility for notifying the Environmental Protection Agency (EPA) and the Federal Aviation Administration.

Contractor must include this requirement in all subcontracts that exceeds \$150,000.

A8 CONTRACT WORKHOURS AND SAFETY STANDARDS ACT REQUIREMENTS

1. Overtime Requirements.

No contractor or subcontractor contracting for any part of the contract work which may require or involve the employment of laborers or mechanics shall require or permit any such laborer or mechanic, including watchmen and guards, in any workweek in which he or she is employed on such work to work in excess of forty hours in such workweek unless such laborer or mechanic receives compensation at a rate not less than one and one-half times the basic rate of pay for all hours worked in excess of forty hours in such workweek.

2. Violation; Liability for Unpaid Wages; Liquidated Damages.

In the event of any violation of the clause set forth in paragraph (1) of this clause, the Contractor and any subcontractor responsible therefor shall be liable for the unpaid wages. In addition, such contractor and subcontractor shall be liable to the United States (in the case of work done under contract for the District of Columbia or a territory, to such District or to such territory), for liquidated damages. Such liquidated damages shall be computed with respect to each individual laborer or mechanic, including watchmen and guards, employed in violation of the clause set forth in paragraph (1) of this clause, in the sum of \$10 for each calendar day on which such individual was required or permitted to work in excess of the standard workweek of forty hours without payment of the overtime wages required by the clause set forth in paragraph (1) of this clause.

3. Withholding for Unpaid Wages and Liquidated Damages.

The Federal Aviation Administration (FAA) or the Owner shall upon its own action or upon written request of an authorized representative of the Department of Labor withhold or cause to be withheld, from any moneys payable on account of work performed by the contractor or subcontractor under any such contract or any other Federal contract with the same prime contractor, or any other federally assisted contract subject to the Contract Work Hours and Safety Standards Act, which is held by the same prime contractor, such sums as may be determined to be necessary to satisfy any liabilities of such contractor or subcontractor for unpaid wages and liquidated damages as provided in the clause set forth in paragraph (2) of this clause.

4. Subcontractors.

The Contractor or subcontractor shall insert in any subcontracts the clauses set forth in paragraphs (1) through (4) and also a clause requiring the subcontractor to include these clauses in any lower tier subcontracts. The prime contractor shall be responsible for compliance by any subcontractor or lower tier subcontractor with the clauses set forth in paragraphs (1) through (4) of this clause.

A9 COPELAND "ANTI-KICKBACK" ACT (Section not applicable.)

A10 DAVIS-BACON REQUIREMENTS (Section not applicable.)

A11 DEBARMENT AND SUSPENSION

CERTIFICATION OF OFFERER/BIDDER REGARDING DEBARMENT

By submitting a bid/proposal under this solicitation, the bidder or offeror certifies that neither it nor its principals are presently debarred or suspended by any Federal department or agency from participation in this transaction.

CERTIFICATION OF LOWER TIER CONTRACTORS REGARDING DEBARMENT

The successful bidder, by administering each lower tier subcontract that exceeds \$25,000 as a “covered transaction”, must verify each lower tier participant of a “covered transaction” under the project is not presently debarred or otherwise disqualified from participation in this federally assisted project. The successful bidder will accomplish this by:

1. Checking the System for Award Management at website: <http://www.sam.gov>.
2. Collecting a certification statement similar to the Certification of Offerer /Bidder Regarding Debarment, above.
3. Inserting a clause or condition in the covered transaction with the lower tier contract.

If the Federal Aviation Administration later determines that a lower tier participant failed to disclose to a higher tier participant that it was excluded or disqualified at the time it entered the covered transaction, the FAA may pursue any available remedies, including suspension and debarment of the non-compliant participant.

A12 DISADVANTAGED BUSINESS ENTERPRISE (Not applicable)

A13 DISTRACTED DRIVING

TEXTING WHEN DRIVING

In accordance with Executive Order 13513, “Federal Leadership on Reducing Text Messaging While Driving”, (10/1/2009) and DOT Order 3902.10, “Text Messaging While Driving”, (12/30/2009), the Federal Aviation Administration encourages recipients of Federal grant funds to adopt and enforce safety policies that decrease crashes by distracted drivers, including policies to ban text messaging while driving when performing work related to a grant or subgrant.

In support of this initiative, the Owner encourages the Contractor to promote policies and initiatives for its employees and other work personnel that decrease crashes by distracted drivers, including policies that ban text messaging while driving motor vehicles while performing work activities associated with the project. The Contractor must include the substance of this clause in all sub-tier contracts exceeding \$3,500 that involve driving a motor vehicle in performance of work activities associated with the project.

A14 ENERGY CONSERVATION REQUIREMENTS

ENERGY CONSERVATION REQUIREMENTS

Contractor and Subcontractor agree to comply with mandatory standards and policies relating to energy efficiency as contained in the state energy conservation plan issued in compliance with the Energy Policy and Conservation Act (42 USC 6201 et seq).

A15 DRUG FREE WORKPLACE REQUIREMENTS

The Drug-Free Workplace Act of 1988 requires some Federal contractors and all Federal grantees to agree that they will provide drug-free workplaces as a condition of receiving a contract or grant from a Federal agency. The Act does not apply to contractors, subcontractors, or subgrantees, although the Federal grantee's workplace may be where the contractors, subcontractors, or subgrantees are working.

A16 EQUAL EMPLOYMENT OPPORTUNITY (EEO) (Section not applicable.)

A17 FEDERAL FAIR LABOR STANDARDS ACT (FEDERAL MINIMUM WAGE)

SOLICITATION CLAUSE

All contracts and subcontracts that result from this solicitation incorporate by reference the provisions of 29 CFR part 201, the Federal Fair Labor Standards Act (FLSA), with the same force and effect as if given in full text. The FLSA sets minimum wage, overtime pay, recordkeeping, and child labor standards for full and part-time workers.

The Contractor has full responsibility to monitor compliance to the referenced statute or regulation. The Contractor must address any claims or disputes that arise from this requirement directly with the U.S. Department of Labor – Wage and Hour Division.

A18 LOBBYING AND INFLUENCING FEDERAL EMPLOYEES

NOTE: Certification is included in the PROPOSAL.

A19 PROHIBITION of SEGREGATED FACILITIES (Section not applicable.)

A20 OCCUPATIONAL SAFETY AND HEALTH ACT OF 1970

CONTRACT CLAUSE

All contracts and subcontracts that result from this solicitation incorporate by reference the requirements of 29 CFR Part 1910 with the same force and effect as if given in full text. The employer must provide a work environment that is free from recognized hazards that may cause death or serious physical harm to the employee. The employer retains full responsibility to monitor its compliance and their subcontractor's compliance with the applicable requirements of the Occupational Safety and Health Act of 1970 (20 CFR Part 1910). The employer must address any claims or disputes that pertain to a referenced requirement directly with the U.S. Department of Labor – Occupational Safety and Health Administration.

A21 PROCUREMENT OF RECOVERED MATERIALS

PROCUREMENT OF RECOVERED MATERIALS

Contractor and subcontractor agree to comply with Section 6002 of the Solid Waste Disposal Act, as amended by the Resource Conservation and Recovery Act, and the regulatory provisions of 40 CFR Part 247. In the performance of this contract and to the extent practicable, the Contractor and subcontractors are to use products containing the highest percentage of recovered materials for items designated by the Environmental Protection Agency (EPA) under 40 CFR Part 247 whenever:

- 1) The contract requires procurement of \$10,000 or more of a designated item during the fiscal year; or
- 2) The contractor has procured \$10,000 or more of a designated item using Federal funding during the previous fiscal year.

The list of EPA-designated items is available at www.epa.gov/smm/comprehensive-procurement-guidelines-construction-products.

Section 6002(c) establishes exceptions to the preference for recovery of EPA-designated products if the contractor can demonstrate the item is:

- a) Not reasonably available within a timeframe providing for compliance with the contract performance schedule;
- b) Fails to meet reasonable contract performance requirements; or
- c) Is only available at an unreasonable price.

A22 RIGHT TO INVENTIONS (Section not applicable.)

A23 SEISMIC SAFETY (Section not applicable.)

A24 TAX DELINQUENCY AND FELONY CONVICTIONS

NOTE: Certification is included in the PROPOSAL.

A25 TERMINATION OF CONTRACT

TERMINATION FOR CONVENIENCE (CONSTRUCTION & EQUIPMENT CONTRACTS)

The Owner may terminate this contract in whole or in part at any time by providing written notice to the Contractor. Such action may be without cause and without prejudice to any other right or remedy of Owner. Upon receipt of a written notice of termination, except as explicitly directed by the Owner, the Contractor shall immediately proceed with the following obligations regardless of any delay in determining or adjusting amounts due under this clause:

1. Contractor must immediately discontinue work as specified in the written notice.
2. Terminate all subcontracts to the extent they relate to the work terminated under the notice.
3. Discontinue orders for materials and services except as directed by the written notice.
4. Deliver to the Owner all fabricated and partially fabricated parts, completed and partially completed work, supplies, equipment and materials acquired prior to termination of the work, and as directed in the written notice.
5. Complete performance of the work not terminated by the notice.
6. Take action as directed by the Owner to protect and preserve property and work related to this contract that Owner will take possession.

Owner agrees to pay Contractor for:

- 1) completed and acceptable work executed in accordance with the contract documents prior to the effective date of termination;
- 2) documented expenses sustained prior to the effective date of termination in performing work and furnishing labor, materials, or equipment as required by the contract documents in connection with uncompleted work;
- 3) reasonable and substantiated claims, costs, and damages incurred in settlement of terminated contracts with Subcontractors and Suppliers; and
- 4) reasonable and substantiated expenses to the Contractor directly attributable to Owner's termination action.

Owner will not pay Contractor for loss of anticipated profits or revenue or other economic loss arising out of or resulting from the Owner's termination action.

The rights and remedies this clause provides are in addition to any other rights and remedies provided by law or under this contract.

TERMINATION FOR DEFAULT (CONSTRUCTION)

Section 80-09 of FAA Advisory Circular 150/5370-10 establishes conditions, rights, and remedies associated with Owner termination of this contract due to default of the Contractor.

TERMINATION FOR DEFAULT (EQUIPMENT)

The Owner may, by written notice of default to the Contractor, terminate all or part of this Contract if the Contractor:

1. Fails to commence the Work under the Contract within the time specified in the Notice- to-Proceed;
2. Fails to make adequate progress as to endanger performance of this Contract in accordance with its terms;
3. Fails to make delivery of the equipment within the time specified in the Contract, including any Owner approved extensions;
4. Fails to comply with material provisions of the Contract;
5. Submits certifications made under the Contract and as part of their proposal that include false or fraudulent statements; or
6. Becomes insolvent or declares bankruptcy.

If one or more of the stated events occur, the Owner will give notice in writing to the Contractor and Surety of its intent to terminate the contract for cause. At the Owner's discretion, the notice may allow the Contractor and Surety an opportunity to cure the breach or default.

If within 10 days of the receipt of notice, the Contractor or Surety fails to remedy the breach or default to the satisfaction of the Owner, the Owner has authority to acquire equipment by other procurement action. The Contractor will be liable to the Owner for any excess costs the Owner incurs for acquiring such similar equipment.

Payment for completed equipment delivered to and accepted by the Owner shall be at the Contract price. The Owner may withhold from amounts otherwise due the Contractor for such completed equipment, such sum as the Owner determines to be necessary to protect the Owner against loss because of Contractor default.

Owner will not terminate the Contractor's right to proceed with the Work under this clause if the delay in completing the work arises from unforeseeable causes beyond the control and without the fault or negligence of the Contractor. Examples of such acceptable causes include: acts of God, acts of the Owner, acts of another Contractor in the performance of a contract with the Owner, and severe weather events that substantially exceed normal conditions for the location.

If, after termination of the Contractor's right to proceed, the Owner determines that the Contractor was not in default, or that the delay was excusable, the rights and obligations of

the parties will be the same as if the Owner issued the termination for the convenience the Owner.

The rights and remedies of the Owner in this clause are in addition to any other rights and remedies provided by law or under this contract.

A26 TRADE RESTRICTION CERTIFICATION

NOTE: Certification is included in the PROPOSAL.

A27 VETERAN'S PREFERENCE

VETERAN'S PREFERENCE

In the employment of labor (excluding executive, administrative, and supervisory positions), the Contractor and all sub-tier contractors must give preference to covered veterans as defined within Title 49 United States Code Section 47112. Covered veterans include Vietnam-era veterans, Persian Gulf veterans, Afghanistan-Iraq war veterans, disabled veterans, and small business concerns (as defined by 15 USC 632) owned and controlled by disabled veterans. This preference only applies when there are covered veterans readily available and qualified to perform the work to which the employment relates.



CERTIFICATE OF LIABILITY INSURANCE

DATE (MM/DD/YYYY)

7/22/2024

THIS CERTIFICATE IS ISSUED AS A MATTER OF INFORMATION ONLY AND CONFERS NO RIGHTS UPON THE CERTIFICATE HOLDER. THIS CERTIFICATE DOES NOT AFFIRMATIVELY OR NEGATIVELY AMEND, EXTEND OR ALTER THE COVERAGE AFFORDED BY THE POLICIES BELOW. THIS CERTIFICATE OF INSURANCE DOES NOT CONSTITUTE A CONTRACT BETWEEN THE ISSUING INSURER(S), AUTHORIZED REPRESENTATIVE OR PRODUCER, AND THE CERTIFICATE HOLDER.

IMPORTANT: If the certificate holder is an ADDITIONAL INSURED, the policy(ies) must have ADDITIONAL INSURED provisions or be endorsed. If SUBROGATION IS WAIVED, subject to the terms and conditions of the policy, certain policies may require an endorsement. A statement on this certificate does not confer rights to the certificate holder in lieu of such endorsement(s).

PRODUCER Arthur J. Gallagher Risk Management Services, LLC 2850 Golf Rd Rolling Meadows IL 60008		CONTACT NAME: Certificate Department PHONE (A/C, No, Ext): FAX (A/C, No): E-MAIL ADDRESS: CertRequests@ajg.com	
INSURED M-B Companies Inc 1615 Wisconsin Avenue New Holstein, WI 53061		AEBISCH-01 INSURER(S) AFFORDING COVERAGE INSURER A : XL Insurance America, Inc. NAIC # 24554 INSURER B : The Travelers Indemnity Company of CT 25682 INSURER C : INSURER D : INSURER E : INSURER F :	

COVERAGES

CERTIFICATE NUMBER: 1312979070

REVISION NUMBER:

THIS IS TO CERTIFY THAT THE POLICIES OF INSURANCE LISTED BELOW HAVE BEEN ISSUED TO THE INSURED NAMED ABOVE FOR THE POLICY PERIOD INDICATED. NOTWITHSTANDING ANY REQUIREMENT, TERM OR CONDITION OF ANY CONTRACT OR OTHER DOCUMENT WITH RESPECT TO WHICH THIS CERTIFICATE MAY BE ISSUED OR MAY PERTAIN, THE INSURANCE AFFORDED BY THE POLICIES DESCRIBED HEREIN IS SUBJECT TO ALL THE TERMS, EXCLUSIONS AND CONDITIONS OF SUCH POLICIES. LIMITS SHOWN MAY HAVE BEEN REDUCED BY PAID CLAIMS.

INSR LTR	TYPE OF INSURANCE	ADDL INSD	SUBR WVD	POLICY NUMBER	POLICY EFF (MM/DD/YYYY)	POLICY EXP (MM/DD/YYYY)	LIMITS
A	<input checked="" type="checkbox"/> COMMERCIAL GENERAL LIABILITY <input type="checkbox"/> CLAIMS-MADE <input checked="" type="checkbox"/> OCCUR GEN'L AGGREGATE LIMIT APPLIES PER: <input checked="" type="checkbox"/> POLICY <input type="checkbox"/> PROJECT <input type="checkbox"/> LOC OTHER:			US00092615LI24A	1/1/2024	1/1/2025	EACH OCCURRENCE \$ 1,000,000 DAMAGE TO RENTED PREMISES (Ea occurrence) \$ 100,000 MED EXP (Any one person) \$ 5,000 PERSONAL & ADV INJURY \$ 1,000,000 GENERAL AGGREGATE \$ 2,000,000 PRODUCTS - COMP/OP AGG \$ 2,000,000 \$
B	<input checked="" type="checkbox"/> AUTOMOBILE LIABILITY <input checked="" type="checkbox"/> ANY AUTO <input type="checkbox"/> OWNED AUTOS ONLY <input checked="" type="checkbox"/> HIRED AUTOS ONLY <input checked="" type="checkbox"/> DEDUCTIBLE <input type="checkbox"/> SCHEDULED AUTOS <input checked="" type="checkbox"/> NON-OWNED AUTOS ONLY <input checked="" type="checkbox"/> See below			8107T771977	9/30/2023	9/30/2024	COMBINED SINGLE LIMIT (Ea accident) \$ 1,000,000 BODILY INJURY (Per person) \$ BODILY INJURY (Per accident) \$ PROPERTY DAMAGE (Per accident) \$ \$
A	<input checked="" type="checkbox"/> UMBRELLA LIAB <input checked="" type="checkbox"/> OCCUR <input type="checkbox"/> EXCESS LIAB <input type="checkbox"/> CLAIMS-MADE DED RETENTION \$			US00092928LI23A	1/1/2024	1/1/2025	EACH OCCURRENCE \$ 10,000,000 AGGREGATE \$ 10,000,000 \$
B	<input checked="" type="checkbox"/> WORKERS COMPENSATION AND EMPLOYERS' LIABILITY ANY PROPRIETOR/PARTNER/EXECUTIVE OFFICER/MEMBER EXCLUDED? <input type="checkbox"/> Y <input checked="" type="checkbox"/> N If yes, describe under DESCRIPTION OF OPERATIONS below		N/A	UB7T808035	9/30/2023	9/30/2024	<input checked="" type="checkbox"/> PER STATUTE <input type="checkbox"/> OTHER E.L. EACH ACCIDENT \$ 1,000,000 E.L. DISEASE - EA EMPLOYEE \$ 1,000,000 E.L. DISEASE - POLICY LIMIT \$ 1,000,000
B	Garagekeepers Coverage			8107T771977	9/30/2023	9/30/2024	Limits: SEE BELOW Deductibles: SEE BELOW

DESCRIPTION OF OPERATIONS / LOCATIONS / VEHICLES (ACORD 101, Additional Remarks Schedule, may be attached if more space is required)

NAMED INSURED:
 M-B Companies, Swenson Spreader, Meyer Products, Monroe Inc. , Monroe Truck Equipment, Monroe Towmaster LLC, Southern Coach
 Kernersville (Carolina Custom Center Inc.)

PRIVATE PASSENGER Comp/Coll \$1,000
 LIGHT TRUCK Comp/Coll \$1,000 \$1,000
 MEDIUM TRUCK Comp/Coll \$2,000 \$2,000
 HEAVY TRUCK Comp/Coll \$3,000 \$3,000
 See Attached...

CERTIFICATE HOLDER**CANCELLATION**

Albany County Airport Authority
 22 Jetway Drive
 Albany NY 12211-1057

SHOULD ANY OF THE ABOVE DESCRIBED POLICIES BE CANCELLED BEFORE THE EXPIRATION DATE THEREOF, NOTICE WILL BE DELIVERED IN ACCORDANCE WITH THE POLICY PROVISIONS.

AUTHORIZED REPRESENTATIVE

© 1988-2015 ACORD CORPORATION. All rights reserved.



ADDITIONAL REMARKS SCHEDULE

AGENCY Arthur J. Gallagher Risk Management Services, LLC		NAMED INSURED M-B Companies Inc 1615 Wisconsin Avenue New Holstein, WI 53061	
POLICY NUMBER		EFFECTIVE DATE:	
CARRIER	NAIC CODE		

ADDITIONAL REMARKS

THIS ADDITIONAL REMARKS FORM IS A SCHEDULE TO ACORD FORM,
FORM NUMBER: 25 **FORM TITLE:** CERTIFICATE OF LIABILITY INSURANCE

HEAVY TRUCK-TRACTOR Comp/Coll \$3,000 \$3,000
 EXTRA HEAVY TRUCKTRACTOR Comp/Coll \$3,000 \$3,000
 TRAILER Comp/Coll \$1,000 \$1,000

1151 W MAIN AVE, DE PERE, WI 54115 Comp/Coll limit: \$3,000,000 Comp/Coll Ded: \$5,000
 1051 W 7TH ST, MONROE, WI 53566 Comp/Coll limit: \$15,000,000 Comp/Coll Ded: \$5,000
 61381 US HIGHWAY 12, LITCHFIELD, MN 55355 Comp/Coll limit: \$3,000,000 Comp/Coll Ded: \$5,000
 812 DRAPER AVE, JOLIET, IL 60432 Comp/Coll limit: \$6,000,000 Comp/Coll Ded: \$5,000
 2400 REO DR, FLINT, MI 48507 Comp/Coll limit: \$24,000,000 Comp/Coll Ded: \$5,000
 1601 E 29TH ST, MARSHFIELD, WI 54449 Comp/Coll limit: \$3,000,000 Comp/Coll Ded: \$5,000
 628 W 10 1/2 ST, MONROE, WI 53566 Comp/Coll limit: \$10,500,000 Comp/Coll Ded: \$5,000
 12001 WESTPORT RD, LOUISVILLE, KY 40245 Comp/Coll limit: \$21,000,000 Comp/Coll Ded: \$5,000
 2625 HOPE CHURCH RD, WINSTON SALEM, NC 27103 Comp/Coll limit: \$21,000,000 Comp/Coll Ded: \$5,000
 RE: Project Description: CONTRACT No. E-1194, Airport Carrier Vehicle With High Speed Snow Blower.

Limited Warranty - Albany International Airport, NY

Limited Warranty: Subject to the limitations set forth herein, M-B Companies, Inc., Airport Maintenance Products division ("M-B") warrants its products to be free from defects in material and workmanship for one (1) year from the date of delivery of the product to its original owner. Engine warranty, five (5) years, Transmission warranty, five (5) years. Parts used for warranty repairs shall be warranted to the end of the Limited Warranty period or ninety days, whichever is longer. This warranty is not transferable without the written consent of M-B.

Notice: M-B's obligations under this Limited Warranty are conditioned on M-B receiving, within the warranty period, written notice from Buyer specifying the nature of any alleged defect and requesting corrective action by Seller.

Remedies: M-B, at its option, will repair or replace, or provide a credit to the buyer for defective warranted items. If requested by M-B, products or parts for which a warranty claim is made shall be returned, transportation prepaid by M-B, to M-B's factory. Buyer shall not return any product for repair, replacement or credit without M-B's advance written consent.

Other Manufacturer's Warranty: On products furnished by M-B, but manufactured by any other manufacturer, the warranty of said manufacturer, if any, will be assigned to the buyer, if the said warranty is assignable. This includes any portion of said manufacturer's warranty which is longer than the M-B standard warranty. However, M-B does not represent or guarantee that the other manufacturer will comply with any of the terms of their warranty.

Exclusions: Any improper use, operation beyond capacity, or substitution of parts not approved by M-B, or alteration or repair by others in such a manner as in M-B's judgment materially and/or adversely affects the product shall void this warranty. This warranty does not apply to defects caused by damage or unreasonable use while in the possession of the owner, including but not limited to: failure to provide reasonable and necessary maintenance, normal wear, routine tune-ups or adjustments, improper handling or accidents, operation at speed or load conditions contrary to published specifications, improper or insufficient lubrication, or improper storage.

The batteries, tires, rubber materials, brushes and material normally consumed in operation, are excluded from this warranty

Limitations of liability: M-B shall not be liable for any incidental, consequential, punitive or special damages of any kind, including, but not limited to, consequential labor costs, transportation charges, and rental costs, in connection with the repair or replacement of defective parts, or lost time or lost profits or expense which may have accrued because of said defect.

M-B disclaims all other warranties, whether expressed or implied, including but not limited to any implied warranty of merchantability or fitness for a particular purpose. This warranty is the exclusive remedy of buyer. This warranty cannot be extended, broadened or changed in any respect except in writing by an authorized officer of M-B.

Notwithstanding anything in this warranty to the contrary, in no event shall M-B's total liability hereunder exceed the purchased price of the particular product.

Warranty Repair Policy

M-B Companies, Inc. Airport Snow Removal Products division ("M-B") warrants its products to be free of defects in material and workmanship as described in the M-B Warranty Policy. The following rules and limitations apply to warranty work and charges performed on behalf of M-B Companies.

Pre-authorization: All warranty work must be pre-authorized by the M-B Service Manager. Claims that are not pre-authorized will be rejected. At the time of pre-authorization, an estimate of labor time will be made by the M-B Service Manager and a pre-authorized limit of charges will be established. If the repair will run over the pre-authorized limit, the organization responsible for doing the work must contact the Service Manager for further approval.

Rates: When warranty repairs are performed by an organization other than M-B, M-B will pay 75% of the organization's standard hourly shop rate or as negotiated. M-B will not pay overtime rates or special road rates. Reimbursement for mileage will be at United States IRS standard rates.

Shop: If M-B personnel or contractor are performing the warranty work, buyer shall supply an adequate, heated, indoor, facility at no charge to M-B. M-B will not pay to rent service shop facilities. Necessary lifting devices, power and hand tools shall also be supplied by the buyer at no charge to M-B.

Parts: M-B reserves the right to review the failed parts to determine warrantability. All parts removed or replaced shall be kept for disposition as directed by M-B. If requested parts are not returned for examination, the warranty claim may be rejected. Warranty work will be performed with parts provided by M-B only, unless arrangements have been made and an agreement reached prior to the repairs. If parts are consumed from a buyer's stock, M-B will credit the buyer what the buyer paid M-B for the parts.

Warranty Claim: Warranty claims will be accepted only if filed within 30 days of the warranty repair. They must be made using the M-B "Warranty Claim Form". Claims for warranty are independent and distinct from other business between M-B and the buyer and/or customer. Payment for warranty will be made by issuance of a credit memo to the account of the buyer. Unauthorized deduction of warranty claims from other amounts owed to M-B will not be recognized.



Warranty Claim Form

Submit M-B Companies Inc. , Airport Maintenance Products 201 MB Lane Claim to: Chilton, WI. 53014 (920)849-2313	M-B Repair Order # _____ Cust Work Order # _____
--	---

Dealer Company Information	Customer/Company Information
Company Name _____ Address _____ _____ Contact Name _____ E-mail Address _____ Phone Number _____	Company Name _____ Address _____ _____ Contact Name _____ E-mail Address _____ Phone Number _____

Failure Date _____ Product Model _____ Hours _____ Miles _____	Repair Date _____ Serial # _____ Customer Unit # _____
--	--

Reason For Claim _____

Corrective Action _____

Parts

Part #	Description	Invoice #	Qty	Price each	Extended
					\$ -
					\$ -
					\$ -
					\$ -
					\$ -
					\$ -
					\$ -
					\$ -
					\$ -
					\$ -
					\$ -
					\$ -
					\$ -
					\$ -
					\$ -
					\$ -
					\$ -
					\$ -
					\$ -

Labor

Qty	Description	Unit cost	Total
			\$ -
			\$ -
			\$ -
			\$ -
			\$ -

Dealer/Customer Authorization Signature: _____ Title: _____	Total Parts Total Labor Claim Total	_____ _____ _____
--	---	-------------------------

MB4 Front Mount Snow Blower and Chassis



Reference Only

- Chassis with four wheel, 4 x 4 drive.
- 164-inch wheel base standard for small turning circles
- Butterfly type hood enclosures for auxiliary and chassis engines cover maintenance catwalks
- All hoods rotate upward to allow maintenance and repair access to engine and accessories
- All hoods open with hand power assist
- 496 HP electronic turbocharged diesel chassis engine, T4F EPA / Stage 5 emission certified with ether start and heated fuel water separator
- Allison RDS 4000, 6 speed transmission
- M-B single speed transfer case, provides low speed torque plus speeds up to 45 mph
 - Automatically locks and releases center differential between front and rear axles
 - Torque bias 50/50 for full time all-wheel drive
- M-B 29,000-pound front drive/steer axle with limited slip differential
- M-B 27,000-pound rear drive/steer axle with limited slip differential
- Tapered spring suspension for smoother ride and increased driver control
- ABS air brake control system (4-channel) with automatic traction control
- Dual 125 gallon fuel tanks for drive and broom engines for up to 12 hours of operation
- 445/65R22.5 LR L traction tread front and rear tires
- Includes battery disconnect switch and centrally located fluid drain lines
- M-B two-man cab
 - Panoramic view. All flat glass for easy and local replacement. Forward slope windshield
 - Four windshield wipers with three motor system for reduced linkage issues and provide better snow removal from windshield
 - Air-ride driver and passenger seats with adjustable lumbar supports
 - Includes many standard features such as side light bars, heated windshield, high capacity cab heater, heated power mirrors, power windows



a brand of aebe schmidt

- Operator friendly, cab integrated microprocessor CAN bus controls with MDC (Monitor, Diagnose, Control) color screen display and CAN joystick for chassis and snowblower
- Unit to be painted to Code 4421

MB4 High Performance Airport Snow Blower Package

- More than 1,000 HP available to power snow blower head
- 755 HP electronic turbocharged diesel T4F EPA / Stage 5 emission certified auxiliary engine
 - delivers all 755 HP to the impeller
 - Ribbon powered by chassis engine
 - More than 300 HP available from chassis engine to drive ribbon as needed
- Capacity up to 7500 tons per hour
- Cast distance in excess of 150 feet
- Cutting height of 58 inches, cutting width of 102 inches
- 52.5" diameter hydrostatic drive ribbon
 - Variable speed ribbon automatically adjusts to ground speed
 - Independently reversible ribbon to free obstructions and clogs
- 59" diameter impeller with replaceable blades, mechanical drive
 - Shear bolts to protect impeller and impeller drive
- Rotating impeller housing and discharge chute for adjustable cast direction
 - 140 degree counterclockwise rotation from flat cast left
- Steel cutting edge
- Pneumatic casters
- Integrated carbide skid shoes

Includes Chassis Options:

- Engine block heater, immersion type
- Coolant filter
- Numbers and lettering on unit
- Rustproofing: under floor, fenders, battery box

Includes Cab Options:

- Air conditioning
- Radio, AM/FM with weather band and Bluetooth
- LED lights on cab light bar, flood, (2)
- LED lights on cab light bar, trapezoid, (2)
- Rear facing LED flood lights
- Amber snow plow lights on cab light bar, (2)
- Mini light bar strobe light on cab
- ICOM A120 radio
- Fire extinguisher, 10A:40BC, 10 lb. with mounting bracket in cab

Includes Snow Blower Engine Options:

- Blower engine block heater, immersion type
- Coolant filter

Includes Snow Blower Spare Parts Options:

- Steel cutting edge
- Pneumatic caster assembly (4)
- Shear bolt kit (50 pins)

M-B Companies, Inc. | Airport Maintenance Products

201 MB Lane | Chilton, WI 53014

1 800 558 5800 | Fax: 920 849 2629 | sales@m-bco.com | www.m-bco.com

In the interest of continuous product improvement, M-B reserves the right to change specifications without notice.

Verisys Registrars®

Helpful Auditing

ISO 9001:2015 Certified

FORM NO.	REV.	DATE	DESCRIPTION

8 7 6 5 4 3 2 1

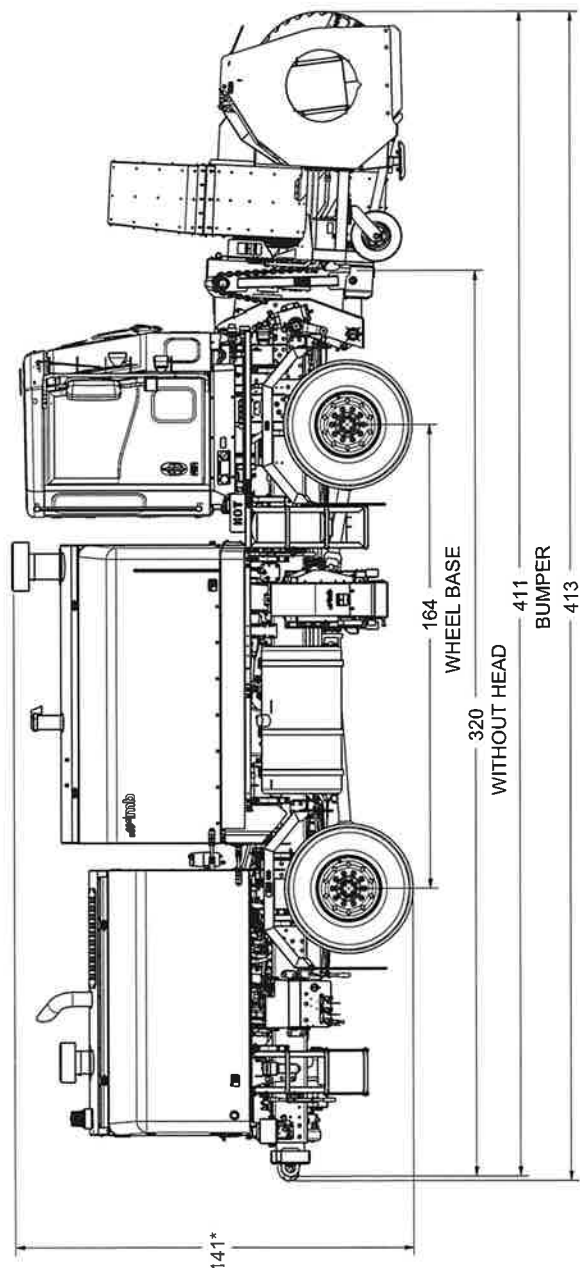
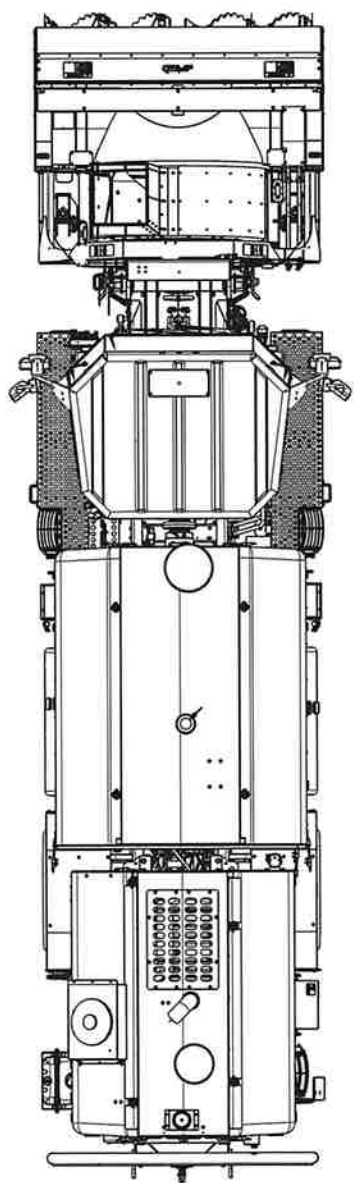

*MAX HEIGHT SHOWN WITHOUT CAB BEACON

FOR REFERENCE ONLY
DIMENSIONS SUBJECT TO CHANGE
UNIT SHOWN WITH OPTIONAL FEATURES

THE DIVISION OF PRODUCTIVITY & LOGISTICS COMPANY, A DIVISION OF THE MILCO GROUP 10000 W. 10TH AVENUE, SUITE 1000 DENVER, CO 80231-1000 PHONE: (303) 440-1000 FAX: (303) 440-1001 WWW.MILCO.COM		MATERIAL SEE BOX TO RANCE PARTS OTHERWISE, INCPRES		SNOWBLOWER CHASSIS, NS4 W M7500	
MFG PART NO. 10000	MFG PART NO. 10000	MFG PART NO. 10000	MFG PART NO. 10000	MFG PART NO. 10000	MFG PART NO. 10000
MFG PART NO. 10000	MFG PART NO. 10000	MFG PART NO. 10000	MFG PART NO. 10000	MFG PART NO. 10000	MFG PART NO. 10000
MFG PART NO. 10000	MFG PART NO. 10000	MFG PART NO. 10000	MFG PART NO. 10000	MFG PART NO. 10000	MFG PART NO. 10000

D C B A

Verisys Registrars®

Helpful Auditing

Certificate of Registration

The Management System of

M-B Companies, Inc.

201 MB Lane Chilton, Wisconsin 53014 USA

has been assessed and certified by Verisys Registrars as meeting the requirements of

ISO 9001:2015

for the following scope of registration:

Design, fabrication, and assembly of snow removal vehicles and attachments

**Certificate
Number**

M020314

IAF Code(s): 18



Management Systems
Certification Body
MSCB-185



Original Approval 2/3/2014

Certificate Issued 2/4/2023

Certificate Expires 2/3/2026

The use of this certification mark
indicates certification in respect to those
activities covered by registration
Certificate Number: M020314

A handwritten signature in blue ink that reads 'Rick Breden'.

On behalf of Verisys Registrars – Rick Breden, President

Verisys Registrars LLC 200 South Executive Drive Suite 101, Brookfield, Wisconsin 53005 USA

This certificate is valid only if the company maintains its management system to the required standard and to conditions and schedules established by Verisys Registrars. In issuing this certificate Verisys Registrars assumes no liability to any party.

1-05-2024

FAA Advisory Circular 150/5520-20A Certification

To: Airport Snow Removal Products Marketing

SUBJECT: FAA Advisory Circular 150/5220-20A Testing Certification for M-B Chassis

M-B Companies Engineering certifies that the following M-B manufactured chassis lines meet the operational standards and testing requirements found in FAA Advisory Circular 150/5220-20A:

MB1 All wheel drive conversion

MB2 Tractor / Plow chassis

MB3 Front-mount broom / plow chassis

MB4 Snow blower chassis

MB5 Mid-mount broom multi-tasking chassis

North Star™ Single Engine Snow Blower chassis



James Steiner

Director Engineering MB Airport

M-B Companies, Inc.

1-05-2024

FAA Vehicle Test Certification

M-B Companies, Inc. hereby certifies that the MB Series chassis fully complies with the Carrier Vehicle Tests as described in Chapter 8, Section 46 of the FAA Advisory Circular Number 150/5220-20A.

These tests were conducted using our early production models and verified the results obtained during our prototype testing.

The Service Brake and the Emergency Brake Tests were conducted during the Federal Motor Vehicle Safety Standard #121 air brake performance certification.

Certification includes:

- 1) Cold Weather Operations at temperatures to -40 degrees F
- 2) Hot Weather Operations at temperatures up to 70 degrees F
- 3) Verification of sufficient power to perform all operational functions simultaneously.
- 4) Ten miles driven over hard surface roads with no perceived problems when loaded to its rated GVW
- 5) One hour at 5 mph over airport terrain when loaded to its rated GVW
- 6) Service Brake Test conducted when loaded to its rated GVW. Vehicle stopped within 35 feet from 20 mph and within 131 feet from 40 mph without steering correction. The tests were run twice in each direction.
- 7) Emergency Brake Test was conducted when loaded to its rated GVW. From 40 mph, the vehicle stopped in under 288 feet using only the emergency brake. No steering corrections were needed and the brakes were able to hold the vehicle without fade for five minutes.

Sincerely,



James Steiner
Director Engineering MB Airport
M-B Companies, Inc.

1-05-2024

M-B Companies, Inc hereby certifies that the model MB series chassis complies with all applicable requirements and regulations that the Federal Motor Vehicle Safety Standards (FMVSS) CFR title 49 part 571

FMVSS 571-101: Controls and Displays

FMVSS 571-102: Transmission Shift Lever Sequence, Starter Interlock, and Transmission Braking

FMVSS 571-103: Windshield Defrosting and Defogging Systems

FMVSS 571-104: Windshield Wiping and Washing Systems

FMVSS 571-105: Hydraulic & Electric Brake Systems (Not applicable on M-B Chassis)

FMVSS 571-106: Brake Hoses

FMVSS 571-108: Lamps, Reflective Devices, and Associated Equipment

FMVSS 571-111: Rearview Mirrors

FMVSS 571-113: Hood Latch Systems (Not applicable on M-B Chassis)

FMVSS 571-116: Motor Vehicle Brake Fluids (Not applicable on M-B Chassis)

FMVSS 571-119: New Pneumatic Tires for Vehicles Other Than Passenger Cars

FMVSS 571-120: Tire Selection and Rims

FMVSS 571-121: Air Brake Systems

FMVSS 571-124: Accelerator Control Systems

FMVSS 571-201: Occupant Protection in Interior Impacts (Not applicable on M-B Chassis)

FMVSS 571-205 (FMCSR 205): Glazing Materials

FMVSS 571-206: Door Locks and Door Retention Components

FMVSS 571-207: Seating Systems

FMVSS 571-208: Occupant Crash Protection

FMVSS 571-209: Seat Belt Assemblies

FMVSS 571-210: Seat Belt Assembly Anchorages

FMVSS 571-302 (FMCSR 302): Flammability of Interior Materials

FMCSR 393.94: Interior Noise Levels in Power Units

FMCSR 393.65: All Fuel Systems



James Steiner
Director Engineering MB Airport
M-B Companies, Inc.

1-05-2024

Drive Components Certification

To: Airport Snow Removal Products Marketing

SUBJECT: MB1, MB2, MB3, MB4, MB5 Series Components Rating Removal

M-B Companies Engineering certifies that the following MB manufactured components installed in the subject vehicles are rated for these vehicles as delivered.

Front Drive/Steer Axles

27K drive/steer axle w/S-cam brakes

29K drive/steer axle w/S-cam brakes

Single Rear Drive/ Steer Axles (Rear steer axle)

27K drive/steer axle w/S-cam brakes

Transfer Cases

MB Nose box assembly 1.63 ratio

MB Up/Down transfer box 1:1

MB Transfer case w/Trutrak differential

Snow Blower Drive Gearbox

MB4 series single speed clutch/drop box

MB4 series single speed impeller drive



James Steiner

Director Engineering MB Airport

M-B Companies, Inc.

To whom it may concern:

This letter serves as a confirmation that M-B Companies have tested the MB4 Chassis with Front Mounted Snowblower performance to verify the tonnage capacity and snow casting ability. I witnessed the testing conducted at the Minneapolis-St. Paul International Airport during the week of January 23, 2023.

This letter certifies that the snow blower testing conducted by M-B Companies complies with the requirements as outlined in FAA Advisory Circular (AC) 150/5220-20A for High Speed Rotary Plows. The testing was completed on a Cat C13B at 496HP and Cat C18 at 755 HP. The peak performance of the equipment is 7600 Tons/hour which exceeds the Extra-Large Class VI Rotary Plow listed in Table 2-3 of the AC.

The also certifies that the snow blower testing conducted by M-B Companies complies with the requirements and procedures outlined in SAE ARP (Society of Automotive Engineers Aerospace Recommended Practice) 5539, "Rotary Plow with Carrier Vehicle" for performance testing.

Sincerely,



Brooke B. Edgar, P.E.

**Albany International Airport, Albany County Airport Authority
Albany, NY, CONTRACT # E-1194,
Airport Carrier Vehicle With High Speed Snow Blower,
Bid Opening Date: August 1, 2024, 11:00 A.M., (EST)**

M-B Companies, Inc. DBE Participation Plan

The M-B Companies has over the past several years sent out solicitations to our supply base inquiring and encouraging our suppliers to participate in the Disadvantaged Business Enterprise (DBE) program.

87 M-B suppliers have been contacted through email and follow up phone calls. Evidence of this is detailed on our attached Good Faith Effort listing.

The solicitation directs the suppliers to the following websites:

Out of state suppliers are directed to: <http://www.dot.gov/osdbu/disadvantaged-business-enterprise/state-dot-and-dbe-program-websites>,

Wisconsin Suppliers are directed to: <http://wisconsindot.gov/Pages/doing-bus/civil-rights/dbe/default.aspx>

As of this date, we have not found a certified DBE supplier for the equipment in this bid.

M-B continues to search for certified DBE's for future opportunities.

M-B Companies - AMP

5/1/2024

Good Faith Effort for:
WBE-MBE-DBE-SBE-VEB

<u>Supplier</u>	<u>Supplier Contact Info</u>	<u>N/A</u>	<u>WBE</u>	<u>MBE</u>	<u>DBE</u>	<u>SBE</u>	<u>VEB</u>	<u>GRS</u>
Metals Engineering	Metals Engineering 1800 South Broadway Green Bay, WI 54304 (920) 339-8590 Phone (920) 339-8592 Fax Rhonda Rusch	X						1
Lenz Inc.	Lenz Inc. 3301 Klepinger Road Dayton, OH 45406 phone 678-641-2852 fax 770-529-1472 Richard Brown	X						1
Kelburn	Kelburn Engineering Company 851 N. Industrial Drive, Elmhurst, IL 60126 P 630-832-8383 x209 F 630-832-8515 Ron Johnson	X						1
Henderson products	Henderson Products Inc. 1085 South Third Street Manchester, IA 52057 563-927-7236 Dennis Meisgeier	X						1
Monarch Ind.	Monarch Industries Limited Phone: 204-786-7921 Ext 219 Fax: 204-772-9496 Toll free: 800-665-0247 Fred Morgan	X						1
J&D Tube Benders	J & D TUBE BENDERS, INC. 8951 Enterprise Way Schofield, WI 54476 1-800-283-8302 1-715-359-8687 FAX Tom Felch	X						1
Falcon Ind.	Falcon Industries, Inc. 901 Astro Blvd. East Cosmos, MN 56228 ☐Telephone: 320-877-7713 ☐Fax: 320-877-7715 Rhonda J. Gass	X						1
Power Systems	Power Systems, LLC 3026C Highway 145 Richfield, WI 53076 p. 262-677-4567 f. 262-677-4655 Donna Peterleus	X						2
Prop Shaft Supply	Prop Shaft Supply 969 Koopman Lane Elkhorn, WI 53121 Office 262-743-1606 Cell 262-492-7799 Joe Kinney		X					1

Arntzen Corp.	Arntzen Corporation 14600 W. Washington St. Woodstock, IL 60098 Ph: 800.957.7655 ext: 221 Fax: 815.334.0778 Ryan D. Moyer	X								1
Northern Iron and Machine	Northern Iron & Machine 867 Forest Street St. Paul, MN 55106 651-778-3320, phone 651-778-3380, fax 763-300-9563, cell Mark Amland	X								1
McNeilus Steel	McNeilus Steel - Fond du Lac, WI 123 East Larsen Drive Fond du Lac, WI 54937 920-923-1778 ext. 5026 Zachary J Todd	X								1
Aurelius MFG.	Aurelius Mfg. Co. Inc. 220 SW 8th Street Braham, MN 55006 Phone - 320-396-3343 Fax - 320-396-3346 Laura Keppler	X								1
Trimark Corp.	Trimark Corp. 510 Bailey Avenue New Hampton, IA 50659 800-431-8616 Terri Troutner	X								1
Gemini Plastics	Gemini Plastics, Inc. 1333 Viking Lane Green Bay, WI 54115 Phone: 800-236-3333 Ken Curry	X								1
Waytek Wire	Waytek Inc. PO Box 81 Chaska, MN 55318 Phone (800)328-2724 X111 Fax (800)858-0319 Travis Dhein	X								1
Cross MFG.	Cross Manufacturing, Inc. 100 James H. Cross Blvd. Lewis, KS 67552 620-324-5525 Mike Worley	X								1
Diesel Components Inc.	Diesel Components Inc. 1500 E Cliff Road Burnsville, MN 55337 PH 952-890-2885 FX 952-890-2920 Nick Fiddle	X								1
Burns Industrial	Burns Industrial W8622 Willis Ray Road Whitewater, WI 53190 414-587-8214 Jim Robinette	X								1

Jay MFG.	Jay Manufacturing Oshkosh, Inc. 2045 West 20th Avenue Oshkosh, WI 54903-3064 Phone: (920) 235-1770 ext. 32 Cell: (920) 573-9151 Fax: (920) 235-2383 John Bores							X	1
Fuel Systems	Fuel Systems Inc. 12730 Robin Lane Brookfield, WI 53005 800-236-3835 Jeff Koppelman	X							1
Therma-Tech	A.R Lintern-Therma-Tech 24900 Capitol Redford, Mi (313)537-5330 ext. 204 Jim Geagan	X							1
Safety Vision	Safety Vision/ICOP 6100 West Sam Houston Parkway North Houston, Texas 77041-5113 800.880.8855 TOLL 713.929.1151 DIRECT 713.896.6600 MAIN 713.896.6640 FAX Terri Molina	X							1
Arrowhead Plastic Engineering	Arrowhead Plastic Engineering, Inc. P.O. Box 75 Eaton, IN 47338 Phone: 765-396-9647 Fax: 765-396-9649 Faith Adair	X							1
Russel Metals	Russel Metals Williams Bahcall PO BOX 210380 Milwaukee, WI 53221 office 414-481-7100 direct 414-982-6666 cell 414-750-2876 Steve DeBot	X							2
Enginaire Inc.	Enginaire Inc. 122 South River Street Janesville, WI 53548 608-755-5466 Ginny Allbee	X							1
Dana Corp.	Dana Holding Corporation Commercial Vehicle Products Group One Village Center Drive Van Buren Twp, MI 48111-5711 Ph: (269) 779-4478 Mark Jeffrey	X							2
Sawbrook Steel	Sawbrook Steel 425 Shepherd Avenue Cincinnati, OH 45215 513-554-1700 Mary Simpson	X							2

Schofield Enterprises	Schofield Enterprises, Inc. 8405 Enterprise Way Schofield, WI 54476 (715)359-2497 Tami Holmes	X							1
Durst	Durst-Regal 5560 E. Buss Road Clinton, WI 53525 D: 608-361-5526 O: 800.356.0775 F: 608.365.6812 Al Bower	X							1
HED	HED Inc. 2120 Constitution Avenue Hartford, WI 53027 (262) 670-2980 Direct (262) 673-9455 Fax Michelle Schmitt	X							1
Weimer Bearing	Weimer Bearing & Transmission 2051 Progress Way Kaukauna, WI 54130 920-766-5463 920-766-5725 fax Ben Cleveland	X							1
Nott Company	Nott Company 3100 East Frontage Road Kaukauna, WI 54130 800-456-0152 x 110 Brian Genke	X							1
NM Transfer Company Inc	NM Transfer Co., Inc. NM Expedited 630 Muttart Road Neenah, WI 54956 800-236-4463 C 920-427-5786 Mark Winter	X							1
IAP Inc	IAP Inc W6905 Paradise Lane Phillips, WI 54555 715-339-3024 Scott Woldt	X							1
Dufeck Wood	Dufeck Wood Products Mfg. 210 Maple Street Denmark, WI 54208 Jodi Weier	X							1
Road Equipment	Road Equipment Parts Center 801 N Bluemound Drive Appleton, WI 54914 920-731-5393 fax 920-731-1712 Bob Momberg	X							1
Knopf	OE Sales div. of Knopf Automotive 600 Corporation Dr. Pendleton, IN 46064 office: 1-765-778-6483 mobile: 1-989-295-3618 Jim Nadolny	X							1

Motion Ind.	Motion Industries-WI09 3669 Enterprise Drive Sheboygan, WI 53083 P 920-208-5600 F 920-208-5618 Torren Nicholas	X							1
Hentzen Coatings, Inc.	Hentzen Coatings, Inc. 6937 West Mill Road Milwaukee, WI 53218-1225 Office: (414) 353-4200 Ex. 56871 Fax: (414) 353-0286 Mobile: (414) 704-4534 Kevin Sehmer	X							1
GS Global Resources, Inc.	GS Hydraulics Sales Inc. 926 PERKINS DRIVE MUKWONAGO, WI 53149 Direct Phone: 262-901-1071 GS Main Fax: 262-786-6787 Jay Stoll	X							1
Industrial Nameplate	Industrial Nameplate, Inc. W6251 Neubert Rd. Appleton, WI 54913 920.731.9105 John Schuldes		X		Applied				1
JTD Enterprises Inc.	JTD Enterprises Inc. 44 Walnut Street Chilton, WI 53014 920-849-2900 Tom Hoban	X			Applied				2
S. Sterling	S. Sterling Company 102 International Drive Peachtree City, GA 30269 770-632-8755 770-632-8756 fax Amanda Collier	X							1
Machine Service Inc	Machine Service Inc 1000 Ashwaubenon Street Green Bay, WI 54304 920-339-3000 x 139 Eric Caelwaerts	X							1
Endries International	Endries International 714 Ryan Street Brillion, WI 54110 T: (920) 756-4584 Todd Marsicek	X							1
Ray's Tire	Ray's Tire 1614 7th Street Green Bay, WI 54304 800-810-5177 David Ellis	X							1
Rychtik Welding & Mfg	Rychtik Welding & Mfg 818 Beech Street Grafton, WI 53024 262-377-1592 Greg Rychtik	X							1

Images on Metal Inc	Images on Metal Inc 105 S Mantorville Avenue Kasson, MN 55944 507-634-1210 Carol Benner	X								1
Hotstart Inc.	Hotstart Inc. E 5723 Alki Avenue Spokane, WA 99212 Ph: 509.536.8669 Cell: 509.954.1000 Jason Cook	X								1
Actia	ACTIA 2809 Bridger Court Elkhart, IN 46514 Ph: 574-266-2640 Fax: 574-266-2740 Lisa Foster	X								1
Flambeau	Flambeau 801 Lynn Ave Baraboo, WI 53913 Phone: 608-355-6568 6568 Fax: 608-355-2245 Katy Morehouse	X								1
Interstate Power Systems	Interstate Power Systems 13015 W. Custer Avenue Butler, WI 53007-0500 Phone 262-783-8702 Mobile 262-441-0884 Fax 262-783-8981 Steve Fredrick	X								2
Fleet Pride	Fleet Pride 743 North Keyser Avenue Scranton, PA 18504 (920) 499-4522 Aaron	X								1
OTR Wheel Engineering, INC.	OTR Wheel Engineering, INC. PO Box 732068 Dallas, TX 75373 706-235-9781 Charles Jackson	X								1
Purosil LLC	Purosil LLC PO Box 1839 Corona, CA 92878 951-271-3900 ext 413 951-271-3901 fax Annie Dinh	X								1
Connector Concepts Inc	Connector Concepts Inc 1530 McCormick Blvd. Mundelein, IL 60060 847-541-4020 Tony Doctor								X	1
Packer City International	Packer City International 611 Hansen Road Green Bay, WI 54306 920-499-0879 Michelle Burt	X								2

ESCO Corp. (Bucyrus)	ESCO Bucyrus 260 E. Beal Avenue Bucyrus, OH 44820 Office: +1 419.563.2673 Toll Free: +1 800.446.3726 Fax: +1 800.642.4542 Brad Timmer	X								1
Olson Trailer & Body	Olson Trailer & Body PO Box 12586 Green Bay, WI 54307 920-499-0881 Tom Johnson	X								1
R. H. Sheppard Co. Inc.	R. H. Sheppard Co. Inc. PO BOX 7383 Lancaster, PA 17604 717-633-4155 Tony Noble	X								1
Commercial Vehicle Group	Commercial Vehicle Group 527 West US Highway 20, Michigan City, IN 46360 Office: (219) 861-2540 Fax: Mobile: (219) 363-6493 Voice IP: 62540 Carla Leake	X								1
SunSource	SunSource 23851 Network Place Chicago, IL 60673 Phone: 952.563.1710 Fax: 800.548.0541 Wendy Sorter	X								1
United Rotary Brush Corp.	United Rotary Brush Corp. PO Box 219911 Kansas City, MO 64121 800-851-5108 Rob Hill	X								1
American Cooling Systems, LLC	American Cooling Systems 3099 Wilson Drive NW Grand Rapids, MI 49544 Office 248-332-7200 Mobile 248-762-1399 Dave Solomon	X								1
Appleton Packing & Gasket	Appleton Packing & Gasket 2809 North Conkey Street Phone - 920-731-4487 Fax - 920-731-6622 Barry Prosser	X								1
Brunner Enterprises										1
Dexter Axle	Dexter Axle 26656 Network Place Chicago, IL 60673 260-636-3033 Vicky Metzger	X								1
Engman-Taylor	Engman-Taylor 3311 E. Capitol Drive Appleton, WI 54912 800-236-3820 Michael West	X								1

Faster Inc.	<p>FASTER INC. 6560 Weatherfield Ct. Maumee, OH 43537 Main Office: 1-800-231-2501 Fax: 1-888-316-2695 Rachel Hake</p>	X							1
Fertilizer Dealer Supply	<p>Fertilizer Dealer Supply PO Box 500 Philo, IL 61864 800-462-6670 Chris Blakeney</p>	X							1
Guenther Supply	<p>Guenther Supply Inc 429 W 11th Street Fond du Lac, WI 54935 Phone - 920-921-0821 Fax - 920-921-5409 Steve Wojahn</p>	X							1
Jagemann Plating Co.	<p>Jagemann Plating Co. 1324 So. 26th Street Manitowoc, WI 54221 920-682-6883 Joe Denor</p>	X							1
Kahlenberg Industries Inc.	<p>Kahlenberg Industries, Inc. P.O. Box 358, 1700 12th St. Two Rivers, WI 54241 Ph: 920-793-4507 x116 Fx: 920-793-1346 Erick Kahlenberg</p>	X							1
Kaman Industrial Technologies Corporation	<p>Kaman Industrial Technologies Corporation 4736 South Taylor Drive, Sheboygan, WI 53081 O: 920-395-7178 F: 920-458-2645 Kelly Kilmartin</p>	X							1
Kundinger Fluid Power									1
Lisowe Fab Weld & Machine LLC	<p>Lisowe Fab, Weld & Machine LLC N2280 Hayton Road New Holstein, WI 53061 920-450-8591 Tel 920-898-5976 Fax Todd Lisowe</p>	X							1
Logan Clutch Corporation	<p>Logan Clutch Corporation Manufacturers of Industrial Clutches and Brakes Tel: (440) 808-4258 Toll Free: (800) 525-8824 Fax: (440) 808-0003 Elyse (Lisa) Logan</p>	X							1
Milcut	<p>Milcut Incorporated N50 W13400 Overview Dr Menomonee Falls, WI 53051 Direct: 262.252.1508 Cell: 262-212-9806 Fax: 262.783.7678 Karl O. Johnson, Veteran USMC</p>	X							1

Molded Dimensions	Molded Dimensions 701 Sunset Road Port Washington, WI 53074 P: 262/284-9455 x 129 F: 262/284-0696 Sarah Post		X							1
MSC Industrial Supply	MSC Industrial Supply 75 Maxess Road Melville, NY 11747 800-645-7270	X								1
Spies Painting, Inc.	Spies Painting, Inc. N8003 Highway 151 Fond du Lac, WI 54937 Ph: (920) 921-7107 Fax: (920) 921-5608 Lisa Schreiber	X								1
Steelwind Ind.										1
Baum Machining	Baum Machine Inc. N253 Stoney Brook Rd. Appleton, WI 54915 Phone 920-738-6613 Cell 920-716-3358 Fax 920-738-0571 Duane Felton	X								1
Centerline Machining and Grinding	Centerline Machining & Grinding, LLC 760 Centerline Drive Hobart, WI 54155 920-544-0825 920-544-0576 - Fax Sara L. Dietzen	X								1
Note: Suppliers highlighted yellow have not responded.										

**WRITTEN CONSENT
OF THE
BOARD OF DIRECTORS
OF
M-B COMPANIES, INC.**

THE UNDERSIGNED, being all the members of the board of directors (the “**Board**”) of **M-B Companies, Inc.**, a Wisconsin corporation (the “**Corporation**”), acting without a meeting pursuant to Section 180.0821 of the Business Corporation Law of the State of Wisconsin, as amended, hereby adopt, by this written consent, the following resolutions with the same force and effect as if they had been adopted at a duly convened meeting of the Board and direct that this written consent be filed with the minutes of the proceedings of the Corporation:

WHEREAS, the Board deems it advisable and in the best interests of the Corporation to adopt the resolutions set forth below.

NOW, THEREFORE, BE IT,

I. Removal of Officer

RESOLVED, that Benjamin Thomke be, and he hereby is, removed as Vice President Pavement of the Corporation effective as of March 13, 2024 (the “**Effective Date**”); and it is further

RESOLVED, that following the officer change authorized and acknowledged in the resolution above, the officers of the Corporation as of the Effective Date are:

Name	Title
Barend Fruithof	Chairman of the Board
Thomas Schenkirsch	Vice Chairman of the Board
Steffen Schewerda	Chief Executive Officer and President
Kurt Ballweg	Chief Financial Officer and Treasurer
Elizabeth Ross	Corporate Controller
Douglas H. Blada	Vice President AMP
Daniel A. Wuersch	Secretary
Joshua Abler	Assistant Secretary
Elizabeth J. Fry	Assistant Secretary
Kevin O’Connell	Plant Controller;

and it is further

II. General Authorization

RESOLVED, that the officers of the Corporation be, and each of them hereby is, authorized and directed, in the name and on behalf of the Corporation, under its corporate seal, or otherwise, to execute and deliver, submit and file any and all resolutions, forms, instruments,

certificates and other documents, and to do any and all other acts and things that each of them shall deem necessary, desirable or appropriate in order to carry out the intent and accomplish the purposes of the foregoing resolutions; and it is further

RESOLVED, that this written consent may be executed in one or more counterparts, all of which shall constitute one and the same instrument.

[signature page follows]

IN WITNESS WHEREOF, the undersigned have executed this written consent as of the Effective Date.

BOARD OF DIRECTORS:

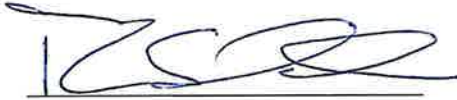
A handwritten signature in blue ink, appearing to read 'T. Schenkirsch', written over a horizontal line.

Thomas Schenkirsch

A handwritten signature in blue ink, appearing to read 'B. Fruithof', written over a horizontal line.

Barend Fruithof

Key Personnel Airport Maintenance Products

Doug Blada (36 years of industry experience)
General Manager – MB Airport
Direct Line: 920-898-1005 | Fax: 920-849-2629
doug.blada@aebi-schmidt.com

Josh Abler (20 years of industry experience)
Manager Inside Sales MB Airport
Direct Line: 920-898-1011 | Fax: 920-849-2629
josh.abler@aebi-schmidt.com

Alan Luke (35 years of industry experience)
Eastern Region and Federal Government Sales Manager
Cell: 804-306-5550 | Fax: 920-849-2629
alan.luke@aebi-schmidt.com

Jessie Carr (8 years of industry experience)
Western Region Sales Manager
Cell: 920-242-4134 | Fax: 920-849-2629
jessie.carr@aebi-schmidt.com

Bill Hecker (40 years of industry experience)
Inside Sales MB Airport
Direct Line: 920-898-1018 | Fax: 920-849-2629
bill.hecker@aebi-schmidt.com

Aaron Schulz (26 years of industry experience)
Manager Product Support/Parts MB Airport
Direct Line: 920-898-1022 | Fax: 920-849-2629
aaron.schulz@aebi-schmidt.com

Ernie Thorp (12 years of industry experience)
Manager, After Sales – North America
Cell: 920-522-2094 | Fax: 920-849-2629
ernie.thorp@aebi-schmidt.com

Stephen McDermott (12 years of industry experience)
Manager Service MB Airport
Cell: 920-483-0288 | Fax: 920-849-2629
stephen.mcdermott@aebi-schmidt.com

Sam Mallman (12 years of industry experience)
Lead Field Service Technician - WI
Cell: 920-522-3660 | Fax: 920-849-2629
sam.mallmann@aebi-schmidt.com

Dustin Young (18 years of industry experience)
Field Service Technician - IN
Cell: 920-242-7075 | Fax: 920-849-2629
dustin.young@aebi-schmidt.com

Aaron Barnes
Field Service Technician - AK
Cell: 253-707-8325 | Fax: 920-849-2629
aaron.barnes@aebi-schmidt.com

(12 years of industry experience)

Chris Carroll
Field Service Technician
Cell: 920-522-3347 | Fax: 920-849-2629
chris.carroll@aebi-schmidt.com

(12 years of industry experience)

Mark Schiesl
Field Service Technician
Cell: 920-483-0183 | Fax: 920-849-2629
mark.schiesl@aebi-schmidt.com

(10 years of industry experience)

Edmund Kenealy
Field Service Technician
Cell: 920-268-3115 | Fax: 920-849-2629
ed.kenealy@aebi-schmidt.com

(10 years of industry experience)

Scott Martin
Field Service Technician
Cell: 920-522-2801 | Fax: 920-849-2629
scott.martin@aebi-schmidt.com

(5 years of industry experience)

Tim Machado
Field Service Technician
Cell: 403-975-6613 | Fax: 920-849-2629
tim.machado@aebi-schmidt.com

(10 years of industry experience)

Craig Uehling
Field Service Technician
Cell: 920-483-0597 | Fax: 920-849-2629
craig.uehling@aebi-schmidt.com

(10 years of industry experience)

James L. Steiner
Chief Engineer
Direct Line: 920-898-1029 | Fax: 920-849-2629
Cell: 920-254-9582
jim.steiner@aebi-schmidt.com

(30 years of industry experience)

Matt Martin
Manager Engineering MB Airport
Cell: 920-797-9320 | Fax: 920-849-2629
matthew.martin@aebi-schmidt.com

(13 years of industry experience)



MB After Sales Point of Contact List



Parts Team

mb.parts@aebi-schmidt.com

Tom Blaul
Parts & Tech Support Manager
920-898-1086

Aaron Schulz
Parts Salesman
920-898-1022

Grady Schulz
Parts Salesman
920-898-8057

Craig Busse
Parts Salesmen
920-898-8024



Service Team

mb.service@aebi-schmidt.com

Steve McDermott
Service Manager
920-843-0288

Sam Mallmann
Lead Technician
920-522-3660

Shelby Thurwachter
Service Writer
920-522-2850



Scan to
Schedule Service



Technical Service

mb.technicalsupport@aebi-schmidt.com

Bryant Basset
Technical Support
920-898-8019



Scan for Oshkosh
Parts Manual
Web Page

M-B Companies, Inc.
201 MB Lane
Chilton, WI 53014
800-558-5800
m-bco.com

AGENDA ITEM NO. 10.2

**Professional Services Contract:
Authorization to Negotiate:
Contract No. S-1196 Professional Engineering Services
for the General Aviation (GA) Apron Reconstruction
with McFarland Johnson, Inc.**

AGENDA ITEM NO: 10.2

MEETING DATE: August 12, 2024

ALBANY COUNTY AIRPORT AUTHORITY
REQUEST FOR AUTHORIZATION

DEPARTMENT:

Contact Person: *John LaClair, P.E. Chief Engineer*

PURPOSE OF REQUEST:

Professional Services Contract: *Authorization to Negotiate: Contract No. S-1196 Professional Engineering Services for the General Aviation (GA) Apron Reconstruction with McFarland Johnson, Inc.*

CONTRACT AMOUNT:

Base Amount: TBD

BUDGET INFORMATION:

Anticipated in Current ALB Capital Plan: Yes ✓ No NA
Funding Account No.: N/A

AWARD CONDITIONS MET:

Apprenticeship N/A DBE Y MWBE N/A

Service Disable Veteran Owned Business (SDVOB) N/A

FISCAL IMPACT - FUNDING (Dollars or Percentages)

Federal 90% State 5% Airport 5% NA
Term of Funding: 2024-2026
Grant No.: <pending> State PIN: <pending>

JUSTIFICATION:

Authorization is requested to negotiate the Professional Services Contract S-1196 General Aviation (GA) Apron Reconstruction design to McFarland Johnson, Inc. of Saratoga, N.Y. An RFQ was advertised and a review committee evaluated the submitted proposals. McFarland Johnson, Inc. received the highest score. The contract award will be contingent upon Board approval of negotiated scope and fee established following FAA grant guidelines.

CHIEF EXECUTIVE OFFICER'S RECOMMENDATION:

Recommend approval.

AGENDA ITEM NO: 10.2
MEETING DATE: August 12, 2024

FINAL AGREEMENT SUBJECT TO APPROVAL BY COUNSEL: YES NA _____

PROCUREMENT DEPARTMENT APPROVAL:

Procurement complies with Authority Procurement Guidelines and Chief Financial Officer has approved. YES NO _____.

BACK-UP MATERIAL:

N/A

AGENDA ITEM NO. 10.3

**Purchase: One (1) 2024 Chevrolet Silverado
2500HD 4WD Crew Cab**

**Joe Basil Chevrolet, Inc.
511 Transit Rd.
Depew, New York 14043**

AGENDA ITEM NO: 10.3
MEETING DATE: August 12, 2024

ALBANY COUNTY AIRPORT AUTHORITY
REQUEST FOR AUTHORIZATION

DEPARTMENT: *Finance*

Contact Person: *Michael Zonsius, Chief Financial Officer*

PURPOSE OF REQUEST:

Purchase: One (1) 2024 Chevrolet Silverado 2500HD 4WD Crew Cab

*Joe Basil Chevrolet, Inc.
511 Transit Rd.
Depew, New York 14043*

AMOUNT: \$51,119,26

BUDGET INFORMATION:

Anticipated in Current Budget: Yes: ✓ No:
Amount remaining from the purchase of Commercial Air Stair Truck

Account String: 2024-79400-60-0000 Dep. 60 FBO – Commercial

FISCAL IMPACT - FUNDING (Dollars or Percentages)

Federal: NA State: NA Airport: 100%

JUSTIFICATION:

Request is made to approve the purchase of one (1) 2024 Chevrolet Silverado 2500HD 4WD Crew Cab for use at the airport's fuel farm. This unit will replace a 2005 Chevrolet Pickup truck. Purchase is authorized pursuant to Procurement Policy, Section 2.11(ii), New York OGS Mini-Bid Reference Number 72324.

The lower two bids received, \$46,687.58 and \$49,507.10 were not selected they did not meet the specifications of the proposal.

CHIEF EXECUTIVE OFFICER'S RECOMMENDATION:

Recommend approval.

FINAL AGREEMENT SUBJECT TO APPROVAL BY COUNSEL:

YES: ✓ NA:

AGENDA ITEM NO: 10.3
MEETING DATE: August 12, 2024

PROCUREMENT DEPARTMENT APPROVAL:

Purchase is consistent with Procurement Policy.

BACK-UP MATERIAL:

1. *Sales Quote*
2. *Bid Tab*
3. *Bid 72324 Specifications*
4. *Bid Response*



2024 Chevrolet Silverado 25000 HD / 4WD Crew Cab



SALES QUOTE

Joe Basil Chevrolet, Inc.
 5111 Transit Rd
 Depew, NY 14043
 Dir.716-206-1764
 Fax 716-685-1746
mkoenig@basilfleet.com

INVOICE NO.
 DATE July 24, 2024
 CUSTOMER ID 960536

NYS DEALER
 #1100005392

TO: Chris Pasquini
 Albany International Airport
 130 Sicker Road
 Latham, NY 12110
 518-242-2379
cpasquini@albanyairport.com

SHIP TO: [Contact Name]
 [Company Name]
 [Street Address]
 [City, ST ZIP Code]
 [Phone]

Salesperson	Customer PO#	Mini Bid	Contract	Option Discount %	Contract Discount %	NYS Discount	PAYMENT TERMS
Matt Koenig		72324	PC68942			INCL	Net 30
VIN#						STK#	

QTY	ITEM #	DESCRIPTION	UNIT PRICE	DISCOUNT	NET TOTAL
1	CK20743	2024 Chevrolet Silverado 2500HD (CK20743) 4WD Crew Cab	\$ 51,119.26	\$ -	\$ 51,119.26
1	1WT	Work Truck Preferred Equipment Group		\$ -	\$ -
1	9L7	Upfitter switch kit, (5)	\$ -	\$ -	\$ -
1	AKO	Glass, deep-tinted	\$ -	\$ -	\$ -
1	AZ3	Seats, front 40/20/40 split-bench	\$ -	\$ -	\$ -
1	C49	Defogger, rear-window electric	\$ -	\$ -	\$ -
1	C7A	Lowered GVWR, 10,000 lbs. (4536 kg)	\$ -	\$ -	\$ -
1	CGN	Chevytec spray-on bedliner	\$ -	\$ -	\$ -
1	DBG	Mirrors, outside power-adjustable vertical trailing	\$ -	\$ -	\$ -
1	GAZ	Summit White	\$ -	\$ -	\$ -
1	GT4	Rear axle, 3.73 ratio	\$ -	\$ -	\$ -
1	H2G	Jet Black, Vinyl seat trim	\$ -	\$ -	\$ -
1	IOR	Audio system, Chevrolet Infotainment 3 system	\$ -	\$ -	\$ -
1	JL1	Trailer brake controller, integrated	\$ -	\$ -	\$ -
1	K34	Cruise control, electronic	\$ -	\$ -	\$ -
1	K4Z	Battery, auxiliary, 700 cold-cranking amps/70 Amp-hr	\$ -	\$ -	\$ -
1	KC9	Power outlet, bed mounted, 120-volt	\$ -	\$ -	\$ -
1	KI4	Power outlet, interior, 120-volt	\$ -	\$ -	\$ -
1	KW5	Alternator, 220 amps	\$ -	\$ -	\$ -
1	L8T	Engine, 6.6L V8	\$ -	\$ -	\$ -
1	MKM	Transmission, Allison 10-Speed automatic	\$ -	\$ -	\$ -
1	NE1	Emissions	\$ -	\$ -	\$ -
1	NZZ	Skid Plates	\$ -	\$ -	\$ -
1	PCV	WT Convenience Package	\$ -	\$ -	\$ -
1	PYN	Wheels, 17" (43.2 cm) painted steel, Silver	\$ -	\$ -	\$ -
1	QT5	Tailgate, gate function manual with EZ Lift	\$ -	\$ -	\$ -
1	QXT	Tires, LT265/70R17E all-terrain, blackwall	\$ -	\$ -	\$ -
1	VK3	License plate kit, front	\$ -	\$ -	\$ -
1	VQO	LPO, Black work step	\$ -	\$ -	\$ -
1	VYU	Snow Plow Prep/Camper Package	\$ -	\$ -	\$ -
1	ZXT	Tire, spare LT265/70R17E all-terrain, blackwall	\$ -	\$ -	\$ -
			\$ -	\$ -	\$ -
		NON-OEM EQUIPMENT	\$ -	\$ -	\$ -
			\$ -	\$ -	\$ -
1	9L7	INSTALL FACTORY ORDERED UPFITTER SWITCH KIT	\$ -	\$ -	\$ -
1	DELIVERY	REGION III	\$ -	\$ -	\$ -
			\$ -	\$ -	\$ -

TOTAL DISCOUNT	\$ -
SUBTOTAL	\$ 51,119.26
SALES TAX	\$ -
TOTAL	\$ 51,119.26



Please Make Checks Payable to Joe Basil Chevrolet, Inc
 Thank you For Your Business

THIS QUOTE SERVES AS YOUR ACKNOWLEDGMENT THAT THIS ORDER HAS BEEN REVIEWED FOR ACCURACY AND DEEMED CORRECT.

Name _____ Title _____ Date _____
 Sign _____ Revised 7/24/2024 9:49

OGS Vehicle Market Place
 Mini Bid # 72324
 (1) Chevrolet Silverado 2500

Vendor	Denoyer Chevrolet	Joe Basil Chevrolet	Mohawk Chevrolet	Nielson Ford of Morristown	Main Motorcar
NYS Base Price	\$ 52,577.26	\$ 51,119.26	\$ 48,133.10	\$ 52,290.22	\$ 46,687.58
NYS Aftermarket Components Price	\$ -	-	\$ 1,374.00		
Total Price	\$ 52,577.26	\$ 51,119.26	\$ 49,507.10	\$ 52,290.22	\$ 46,687.58
				*Bid 2024 F250	*Bid 2024 RAM 2500

Group 40440, Award 23166, Vehicles, Class 1-8

Form A (Single OEM Specific Make/Model): Mini-Bid Request

Revised 01/05/24

MINI-BID SUMMARY	
Mini-Bid Name <i>[Auto-populated based on entries below in the Mini-Bid Reference Number, Number of Vehicles, Make, Model and Trim Level, and Authorized User Entity Name fields]</i>	OGS 23166 - 72324 - (1) ChevroletSilverado 2500 - Albany County Airport Authority
Mini-Bid Reference Number <i>[Enter the internal number assigned by your entity. If this is a rebid, indicate that in parenthesis next to the Mini-Bid Reference Number, e.g.: 19100158 (rebid of 19100157)]. (Note: This number will be used by the Vehicle Dealer to track your Mini-Bid, and is a mandatory field)</i>	72324
Mini-Bid Release Date <i>[Enter the date that this Mini-Bid Request will be sent to the Vehicle Dealers]</i>	7/25/2024
Mini-Bid Response Due Date <i>[Enter the date that Mini-Bid Responses are due from the Vehicle Dealers] (Note: From the date of release of a Mini-Bid request, Contractors Shall have five (5) business days to submit a response for Single OEM Vehicles. The Mini-Bid response submittal deadline may be set with a longer or shorter duration than the standard five (5) business days at the discretion of the Authorized User)</i>	8/2/2024
Mini-Bid Response Due Time <i>[Enter the time that Mini-Bid Responses are due from the Vehicle Dealers] (All times Eastern Time)</i>	11:00 AM

PART A: AUTHORIZED USER CONTACT INFORMATION

1.0	Is your entity a State Agency (e.g., NYS Department of Transportation), or a Non-State Agency (e.g., Albany County Department of Public Works)? <i>[click on yellow box and use drop-down menu]</i>	Non-State
2.0	Authorized User Entity Name <i>[Enter the name of your state agency, municipal government office, or other NYS authorized contract user entity name]</i>	Albany County Airport Authority
3.0	City (or Town, Village, etc.) where the Authorized User Entity is located <i>[if there is more than one location, enter the location of the office that is completing this form]</i>	Colonie
4.0	County where the above City (or Town, Village, etc.) is located <i>[click on yellow box and use drop-down menu]</i>	Albany
5.0	Primary Contact Name <i>[Designated Contact for Procurement Lobbying, if applicable. See http://ogs.ny.gov/acpl/advisoryCouncil/Entities.htm]</i>	Bobbi Matthews
5.1	Primary Contact Title	Purchasing Agent
5.2	Primary Contact Email	bmatthews@albanyairport.cin
5.3	Primary Contact Phone	5182422213
6.0	Secondary Contact Name <i>[Designated Contact for Procurement Lobbying, if applicable. See http://ogs.ny.gov/acpl/advisoryCouncil/Entities.htm]</i>	
6.1	Secondary Contact Title	
6.2	Secondary Contact Email	
6.3	Secondary Contact Phone	

PART B: GENERAL QUESTIONS

1.0	Has the Authorized User received the necessary internal and external approvals that your organization or oversight authority requires for this request? <i>[click on yellow box and use drop-down menu]</i> <i>(Note: Authorized Users are advised that it is their responsibility to secure the necessary approvals. A Mini-Bid request for NYS Executive Agencies is required to have a business case, B-1184 number and the approval of OGS Fleet Management prior to distributing the Mini-Bid)</i>	Yes
2.0	B-1184 Number (e.g., 1140000-97-2016) <i>[for NYS Executive Agencies only]</i>	
3.0	Approved Business Case Number (e.g. BC050) <i>[for NYS Executive Agencies only]</i>	
4.0	Will the vehicles requested in the Mini-Bid be purchased or leased?	Purchased
5.0	Specify the anticipated method and timeframe for issuing Purchase Orders for the vehicles requested.	One-time purchase for the total number of Vehicles requested

PART C: MINI-BID PROCESS

1.0	<p>Type of Vehicle Order: <i>[click on yellow box and use drop-down menu]</i></p> <p><u>"Vehicle(s) Built to Specifications"</u>: Vehicle(s) that will be ordered directly from the OEM and built to the specifications identified by the Authorized User on Form A (Single OEM Vehicle): <i>Mini-Bid Request</i>. <i>[Note: This type of vehicle will be ordered from the OEM factory to meet your specifications, and will be delivered as soon as possible after the Contractor receives the order. Delivery times can range from 6 weeks to 6 months, depending on the OEM production schedule.]</i></p> <p><u>"Pre-Existing Inventory Vehicle(s)"</u>: Vehicle(s) that were manufactured by the OEM prior to release of the Mini-Bid Request. Pre-Existing Inventory Vehicle(s) may either be located at the Contractor's business location, or other Delivery Origin. <i>[Note: This type of vehicle is currently located on a Dealer's lot, and should only be requested if there is an immediate need for a vehicle with standard options. Inventory is limited and the Contractors may not have any vehicles available that meet the Authorized User's minimum specifications. Also, per the Contract, the Contractor is only obligated to hold this type of vehicle for ten (10) calendar days from the date of the Mini-Bid' Response Due Date, so the Authorized User must have the ability to issue the Purchase Order within a short timeframe.]</i></p>	Vehicle(s) Built to Specifications
1.1	If "Vehicle(s) Built to Specifications" were specified for Question 1.0, will you consider "Pre-Existing Inventory Vehicle(s)" if the Mini-Bid responses received include "Pre-Existing Inventory Vehicle(s)" that meet your requirements? <i>[click on yellow box and use drop-down menu]</i>	Yes
1.2	<p>If "Pre-Existing Inventory Vehicle(s)" were specified for Question 1.0, will you consider "Vehicle(s) Built to Specifications" if one of the following conditions occurs?</p> <p>a) there are no Mini-Bid responses received for "Pre-Existing Inventory Vehicle(s)," or</p> <p>b) the Mini-Bid responses received do not meet your requirements, or</p> <p>c) the "Vehicle(s) Built to Specifications" have a lower price?</p> <p><i>[click on yellow box and use drop-down menu]</i></p>	N/A, "Pre-Existing Inventory Vehicle(s)," were not specified for Question 2.0
2.0	<p>Method of Award for purchase of "Vehicle(s) Built to Specifications": <i>[click on yellow box and use drop-down menu]</i></p> <p><u>"N/A,"</u> this Mini-Bid Request is either for a vehicle that will be leased, <u>OR</u> is for "Pre-Existing Inventory Vehicle(s)" only, and "Vehicle(s) Built to Specifications" will not be considered for award.</p> <p><u>"Lowest price to a single contractor"</u> that can provide the total number of vehicles requested.</p> <p><u>"See Additional Vehicle Specifications document."</u> <i>[Choose this option if a delivery date deadline for the Vehicle(s) will be used to determine the award of the Mini-Bid. For example, "Delivery must be made by the end of the fiscal year, March 31, 20XX." This delivery date criteria must be disclosed on the Additional Vehicle Specifications document.]</i></p>	Lowest price to a single contractor
3.0	<p>Method of Award for purchase of "Pre-Existing Inventory Vehicle(s)": <i>[click on yellow box and use drop-down menu]</i></p> <p><u>"N/A,"</u> this Mini-Bid Request is either for a vehicle that will be leased, <u>OR</u> is for "Vehicle(s) Built to Specifications" only, and "Pre-Existing Inventory Vehicle(s)" will not be considered for award.</p> <p><u>"Lowest price to a single contractor"</u> that can provide the total number of vehicles requested. <i>[Choose this option if award will only be made if all vehicles requested can be provided by one Contractor. Note: Inventory is limited and Contractors generally do not have a large number of "Pre-Existing Inventory Vehicles" available.]</i></p> <p><u>"Lowest price per Vehicle,"</u> to multiple Contractors. <i>[Choose this option if award will be made to the number of Contractors required to fulfill the vehicle request, and multiple Purchase Orders can be issued.]</i></p> <p><u>"See Additional Vehicle Specifications document."</u> <i>[Choose this option if a delivery date deadline for the Vehicle(s) will be used to determine the award of the Mini-Bid. For example, "Delivery must be made by the end of the fiscal year, March 31, 20XX." This delivery date criteria must be disclosed on the "Additional Vehicle Specifications" document.]</i></p>	Lowest price to a single contractor
PART D: VEHICLE REQUEST INFORMATION		
1.0	Number of Vehicles <i>[This amount is the estimated number of vehicles that the Authorized User will purchase from the Mini-Bid in the event of an award. The Authorized User reserves the right to partially award a Mini-Bid for a number of Vehicles that is less than number of Vehicles specified.]</i>	1

2.0	<p>Vehicle Type <i>[click on yellow box and use drop-down menu]</i></p> <p>Sedan, Small: Passenger and cargo volume is under 110 cubic feet Sedan, Mid-Size: Passenger and cargo volume is 111 to 119 cubic feet Sedan, Large: Passenger and cargo volume is 120 or more cubic feet MPV/SUV, Small: With a length under 167 inches MPV/SUV, Mid-Size: With a length roughly between 168-180 inches MPV/SUV, Full-Size: With a length 181 inches or more Van, Full-Size (Cargo/Utility) Van, Full-Size (Passenger) Van, Mini-Van (Cargo/Utility) Van, Mini-Van (Passenger) Mini Pickup Truck: Gross Vehicle Weight Rating is typically less than or equal to 6,000 pounds Full Size Pickup Truck: Gross Vehicle Weight Rating is typically above 6,000 pounds Hatchback/Five Door (Specify size in 'Additional Specifications' document) Other (Specify below)</p>	Full Size Pickup Truck: GVWR > 6,000 pounds
2.1	If the desired Vehicle Type is not included in the drop-down menu, enter it here	
3.0	Model Year <i>[Enter the specific Model Year requested]</i> (e.g., 2024, 2025)	2024
3.1	If a specific year was entered above, will you consider other years, if offered? <i>[click on yellow box and use drop-down menu]</i>	
4.0	Make <i>[Enter the specific Make requested]</i> (e.g., Ford, Chevrolet, or Dodge)	Chevrolet
5.0	Model and Trim Level <i>[Enter the specific Model and Trim Level requested]</i> (e.g., Taurus SE, Tahoe LS, Grand Caravan AVP)	Silverado 2500
6.0	Model Code <i>[enter Model Code, if known, or "Any Model Code that meets specifications"]</i>	HD
7.0	Cab Type <i>[click on yellow box and use drop-down menu. For a pickup truck, enter the cab type. For other vehicle types, select "N/A"]</i>	Crew Cab (Quad Cab, Double Cab, SuperCrew, CrewMax)
7.1	Drive Type (e.g., FWD, RWD, AWD, 4WD, "AWD or 4WD," "Any Drive Type," or "Other (Specify in Additional Vehicle Specifications)")	AWD or 4WD
8.0	<p>Fuel Type <i>[click on yellow box and use drop-down menu]</i></p> <p>(Note: If choosing a Fuel Type other than "Gasoline Only," conduct research to verify that there are vehicles available with that Fuel Type that will meet all specifications. Flex Fuel (Gasoline/E85), for example, is available in a limited number of Models, some of which may not be available in NYS, or may require a special order code. The US Department of Energy lists current alternate fueled vehicles at http://www.afdc.energy.gov/vehicles/search, however, the information found there should be verified with a NYS vehicle dealer.)</p>	Gasoline Only
8.1	If the desired Fuel Type is not included in the drop-down menu, enter it here	
9.0	<p>Aftermarket Components Provider <i>[click on yellow box and use drop-down menu]</i></p> <p><i>[The Authorized User may specify that "Aftermarket Components" be included with the Vehicle. "Aftermarket Component(s)" refers to any accessory, equipment, or feature that is manufactured by an OEM other than the vehicle OEM, and is not included in the OEM Product Line, and that may be installed on the vehicle by the Contractor, or third-party. Examples include emergency lights, snow plow, cameras, tow and trailer equipment. Unless otherwise specified by an Authorized User in a Mini-Bid, Aftermarket Components may be installed by any Aftermarket Component Provider utilized in the Contractor's normal course of business.]</i></p> <p>"N/A," There are no "Aftermarket Components" to be included in the Vehicle(s).</p> <p>"Any Provider" may be used for providing/installing the "Aftermarket Components" specified in the "Additional Vehicle Specifications" document.</p> <p>"See 'Additional Vehicle Specifications' document" for the contact information for the required provider/installer of the "Aftermarket Components" specified in the "Additional Vehicle Specifications" document.</p>	N/A
PART E: AUTHORIZED USER SPECIFICATIONS		
1.0	Have you completed an Additional Vehicle Specifications document for your Vehicle request? <i>[click on yellow box and use drop-down menu]</i> (see "Buyer Instructions" tab for additional information)	Yes
2.0	Additional Vehicle Specifications File Name <i>[Auto-populated based on entries above in the Mini-Bid Reference Number, Number of Vehicles, Make, Model and Trim Level, and Authorized User Entity Name fields]</i> (Note: Use this name to identify the specifications file that is attached to the email with this Form A for the Mini-Bid Request that is distributed to Vehicle Dealers)	OGS 23166 - 72324 - (1) ChevroletSilverado 2500 - Albany County Airport Authority - Specs
PART F: DELIVERY INFORMATION <i>[Enter the Vehicle delivery location and information below. If there is more than one delivery location, enter "Multiple" as applicable in the fields below, and include the requested information for each delivery location on a separate page within the Additional Vehicle Specifications document]</i>		
1.0	Delivery Date <i>[Enter either the last possible delivery date that the Vehicles will be accepted at the delivery location, or enter "ASAP" if the delivery date will not be considered in award of the Mini-Bid.]</i>	asap

GROUP 40440 – Vehicles, Class 1-8

2.0	Delivery Location Name	Albany international airport
2.1	Number of requested Vehicles to be delivered to this location	1
2.2	Address	130 Sicker Road
2.3	City	Latham
2.4	State	NY
2.5	Zip Code	12211
2.6	County	Albany

2024 Chevrolet Silverado 2500 HD / 4WD Crew Cab

Work Truck Preferred Equipment

Upfitter Switch Kit, (5)

Glass, deep Tinted

Seats, Front 40/20/20 Split Bench

Defogger, Rear Window Electric

Lowered GVWR, 10,000lbs.

Chevy tec, spray on bed liner

Mirrors, outside power adjustable vertical trailering

summit white

rear axle, 3.73 ratio

jetblack vinyl seat trim

audio system, chvrolet infotainment 3 system

trailer brake controller, integrated,

cruise control, electronic

battery, auxiliary, 700 cold cranking amps / 70 amp hr

power outlet, bed mounted 120 volt

alternator 229 amps

engine, 6.6 l v8

transmission, allison 10 speed automatic

emissions

skid plates

WT Convenience Package

Wheels, 17" (43.2 cm) paintend steel, silver

Tailgate, gate function manual with EZ Lift

Tires, LT265/70R17E all terrain, blackwall

license plate kit, front

LPO, Black Work step

Snow Plow Prep/ Camper Package

Tire, Spare LT 265/70R17E all Terrain,blackwall

Non OEM Equipment: Install factory ordered upfitter switch Kit

Group 40440, Award 23166, Vehicles, Class 1-8

Form A (Single OEM Specific Make/Model): *Mini-Bid Request*

MINI-BID SUMMARY	
Mini-Bid Name	OGS 23166 - 72324 - (1) ChevroletSilverado 2500 - Albany County Airport Authority
Mini-Bid Reference Number	72324
Mini-Bid Release Date	7/25/2024
Mini-Bid Response Due Date	8/2/2024
Mini-Bid Response Due Time (Eastern Time)	11:00 AM
Purchased or leased?	Purchased
BUYER CONTACT INFORMATION	
State or Non-State Entity?	Non-State
Authorized User Entity Name	Albany County Airport Authority
Town/Village/City & County	Colonie, Albany County
Primary Contact Name & Title	Bobbi Matthews, Purchasing Agent
Primary Contact Email & Phone	bmatthews@albanyairport.cin, 5182422213
Secondary Contact Name & Title	Enter Data on Form A
Secondary Contact Email & Phone	Enter Data on Form A
MINI-BID PROCESS	
Anticipated method and timeframe for purchase	One-time purchase for the total number of Vehicles requested
Type of Vehicle(s) requested	Specific Vehicle(s)
Type of Vehicle Order	Vehicle(s) Built to Specifications
If Built to Specifications, Pre-Existing Inventory Vehicle(s) also considered?	Yes
If Pre-Existing Inventory, Vehicle(s) Built to Specifications also considered?	N/A, "Pre-Existing Inventory Vehicle(s)," were not specified for Question 2.0
Method of Award for "Vehicle(s) Built to Specifications"	Lowest price to a single contractor
Method of Award for "Pre-Existing Inventory Vehicle(s)"	Lowest price to a single contractor
VEHICLE INFORMATION	
Number of Vehicles	1
Vehicle Type	Full Size Pickup Truck: GVWR > 6,000 pounds
Model Year	2024
Other Model Years considered?	Enter Data on Form A
Make	Chevrolet
Model and Trim Level	Silverado 2500
Model Code	HD
Cab Type	Crew Cab (Quad Cab, Double Cab, SuperCrew, CrewMax)
Drive Type	AWD or 4WD
Fuel Type	Gasoline Only
Aftermarket Components Provider	N/A
ADDITIONAL SPECIFICATIONS	
Additional Vehicle Specifications File Name	OGS 23166 - 72324 - (1) ChevroletSilverado 2500 - Albany County Airport Authority - Specs
DELIVERY INFORMATION (If "Multiple" is listed, see the Additional Specifications document for all delivery locations)	
Delivery Date	asap
Delivery Location Name	Albany international airport
Number of Vehicles to be delivered to this location	1
Delivery Address	130 Sicker Road
Delivery City, State, Zip Code	Latham, NY 12211

Delivery County	Albany County
-----------------	---------------

Group 40440-23166, VEHICLES, Class 1-8 (Vehicle Marketplace)

Form B (Single OEM Vehicle): Mini-Bid Response

Form Revision: 9/12/23

Part A: Mini-Bid and Contractor Information	
1.0 Mini-Bid Questions	Contractor Response
1.1 Mini-Bid Reference Number (e.g. 12345; see the Mini-Bid Request)	72324
1.2 Is the Mini-Bid for Vehicle(s) to be purchased or leased by the Authorized User? <i>[click on yellow box and use drop-down menu]</i>	Purchased
1.3 Are Vehicle(s) Built to Specifications being offered in response to the Mini-Bid? <i>[click on yellow box and use drop-down menu]</i>	No, Part B of this form has been left blank.
1.4 Are Pre-Existing Inventory Vehicle(s) being offered in response to the Mini-Bid? <i>[click on yellow box and use drop-down menu]</i>	Yes, Part C of this form has been completed.
2.0 Contractor Information	
2.1 Full Legal Business Name, including DBA if applicable	Joe Basil Chevrolet
2.2 OGS Contract Number (e.g., PC12345)	PC88942
2.3 Federal Employer Identification Number / FEIN (e.g. 14-1234567)	16-1068991
2.4 NYS Vendor ID Number (e.g., 1000012345)	1100005392
3.0 Primary Contact Information	
3.1 Contact Name	Matt Koenig
3.2 Contact Email	mkoenig@basilmeet.com
3.3 Contact Phone (1)	716-206-1764
3.4 Contact Phone (2)	
4.0 Secondary Contact Information	
4.1 Contact Name	
4.2 Contact Email	
4.3 Contact Phone (1)	
4.4 Contact Phone (2)	

Part B: Vehicle(s) Built to Specifications offered for Mini-Bid	
1.0 General Questions (Built to Spec)	Contractor Response
1.1 Does the Vehicle offered meet all Authorized User Specifications for the requested Vehicle? <i>[Note: General specifications, and an "Additional Vehicle Specifications Document(s)" are included with each Mini-Bid Request]</i>	
1.2 Enter the estimated number of days after receipt of a Purchase Order, or other ordering document, that the delivery will be made.	
1.3 Enter the Final Order Due Date for the Vehicle offered for the Mini-Bid, or "TBA" if the date has not been announced by the manufacturer.	
2.0 Vehicle Offered (Built to Spec)	
2.1 Model Year (e.g., 2023, 2024)	
2.2 Make (e.g., Ford, Chevrolet, Dodge)	
2.3 Model (e.g., Taurus, Tahoe, Grand Caravan), and Trim Level (e.g., SE, LE, XL)	
2.4 Model Code (the OEM code used to identify a particular subset of a Vehicle Model)	
2.5 Drive Type <i>[click on yellow box and use drop-down menu]</i>	
If the offered Drive Type is not included in the drop-down menu, enter it here	
2.6 Fuel Type <i>[click on yellow box and use drop-down menu]</i>	
If the offered Fuel Type is not included in the drop-down menu, enter it here	
2.7 Enter the vendor business name(s) of the Aftermarket Components Provider(s), if applicable. If not applicable, enter "N/A".	
3.0 Additional Information (Built to Spec)	
3.1 If applicable, enter any deviations from the Authorized User Specifications, or other additional information applicable to this Mini-Bid. Bidders are strongly encouraged to submit proposed deviations to the Authorized User by email prior to the Mini-Bid Response Due Date, so that they may be given due consideration prior to the submission of Bids. Do not enter information about Options or Aftermarket Components available for the Vehicle offered, unless it has been included in the Authorized User Specifications. If not applicable, enter "N/A".	
4.0 Vehicle Price Worksheet (Built to Spec)	
	Price
4.1 NYS Base MSRP	
4.2 NYS Discount <i>[Type a number only (e.g., 5.5); Do not type a percentage sign (%) after the number; For 5.5% type 5.5, not 0.055]</i>	
4.3 NYS Base Price <i>[Automatically calculated: NYS Base MSRP minus NYS Discount]</i>	\$0.00
4.4 NYS Aftermarket Components Price <i>[If there are no Aftermarket Components, leave blank]</i>	
4.5 NYS Price for the Vehicle <i>[Automatically calculated: NYS Base Price plus NYS Aftermarket Component Price]</i>	\$0.00
4.6 Number of Vehicles <i>[This quantity must match the Number of Vehicles specified by the Authorized User in the Mini-Bid Request]</i>	
4.7 Total Price for Mini-Bid <i>[Automatically calculated: NYS Price for the Vehicle multiplied by Total Number of Vehicles]</i>	Enter Pricing

Part C: Pre-Existing Inventory Vehicle(s) offered for Mini-Bid	
1.0 General Questions (Pre-Existing)	Contractor Response
1.1 Do the Vehicle(s) offered meet all Authorized User Specifications for the requested Vehicle? <i>[click on yellow box and use drop-down menu]</i> <i>[Note: General specifications, and an "Additional Vehicle Specifications Document" are included with each Mini-Bid Request. A Vehicle offered that does not meet all Authorized User Specifications may be deemed non-responsive and may be rejected.]</i>	Yes
1.2 Will the Vehicle(s) and pricing offered for the Mini-Bid Response remain firm and not be withdrawn for at least ten (10) calendar days from the first business day immediately following the Mini-Bid response submittal deadline, or such other period of time as specified in the Mini-Bid Request, in accordance with the Contract (see Section 2.42 Procurement Method, Paragraph G Timeframe for Offers in Mini-Bids)? <i>[click on yellow box and use drop-down menu]</i>	Yes
2.0 Additional Information (Pre-Existing)	
2.1 If applicable, enter any deviations from the Authorized User Specifications, or other additional information applicable to this Mini-Bid. Bidders are strongly encouraged to submit proposed deviations to the Authorized User by email prior to the Mini-Bid Response Due Date, so that they may be given due consideration prior to the submission of Bids. Do not enter information about Options or Aftermarket Components available for the Vehicle offered, unless it has been included in the Authorized User Specifications. If not applicable, enter "N/A".	
N/A	
3.0 Vehicle Price Worksheet (Pre-Existing)	

[If more than fifteen (15) Pre-Existing Inventory Vehicles are being offered for a Mini-Bid, submit an additional completed Form B (Single OEM Vehicle): Mini-Bid Response form for the Mini-Bid. Submit both Form Bs following the instructions at the top of this Form, using the following naming convention for the additional Form B "OGS 23166-XXXXXXX-PC12345-Additional Vehicles" (i.e., OGS Award#-Mini-Bid Reference#-Contract#-Additional Vehicles).]

GROUP 40440 – Vehicles, Class 1-8

Ref. #	Model Year	Make	Model and Trim Level	Model Code	Exterior Color	Interior Color	Seat Fabric	Drive Type	Fuel Type	NYS Base MSRP	NYS Discount	NYS Base Price	NYS Aftermarket Components Price	NYS Price for Vehicle
(Example)	2023	Chevrolet	Traverse	CV14526	Blue Metallic	Dark Titanium	Cloth	FWD	Gasoline	\$41,500.00	5.00	\$39,425.00	\$1,500.00	\$40,925.00
001	2024	Chevrolet	Silverado 2500HD Crew Cab 159 Work Truck	CK20743	Summit White	Jet Black	Vinyl	4WD	Gasoline	\$55,010.00	7.40	\$50,939.26	\$180.00	\$51,119.26
002														
003														
004														
005														
006														
007														
008														
009														
010														
011														
012														
013														
014														
015														
													Total Price for Mini-Bid	\$51,119.26
													Total Pre-Existing Vehicles Offered	1

AGENDA ITEM NO. 10.4

**Approval of a contract with Capital
Digitronics for the purchase and installation of radios
and accompanying equipment.**

AGENDA ITEM NO: 10.4
MEETING DATE: August 12, 2024

ALBANY COUNTY AIRPORT AUTHORITY
REQUEST FOR AUTHORIZATION

DEPARTMENT: *Finance*

Contact Person: *Christine C. Quinn, Airport Counsel*

PURPOSE OF REQUEST:

Approval of a contract with Capital Digitronics for the purchase and installation of radios and accompanying equipment.

Capital Digitronics, 264 Bradford Street, Albany, New York 12206

AMOUNT:

Total: \$269,000.11

BUDGET INFORMATION:

Anticipated in Current Budget: Yes No

FISCAL IMPACT - FUNDING (Dollars or Percentages)

Federal: State: Airport: 100% NA:

JUSTIFICATION:

Request is made to approve the purchase and installation of radios and accompanying equipment as a part of the airports radio upgrade project for \$269,000.11 from Capital Digitronics. This includes Station Equipment, Base Radio, Mobile Radios, Portable Radios & Labor. This new digital system will provides a significant and needed upgrade offering greater capabilities, greater interoperability between departments, private channels and consolidation of current radio system. Purchase is being made under a New York State Office of General Services contract.

EXECUTIVE OFFICER'S RECOMMENDATION:

Recommends approval.

AGENDA ITEM NO: 10.4
MEETING DATE: August 12, 2024

FINAL AGREEMENT SUBJECT TO APPROVAL BY COUNSEL:

YES: ✓ NA:

PROCUREMENT DEPARTMENT APPROVAL:

Procurement complies with Authority Procurement Guidelines and Chief Financial Officer has approved. YES ✓ NO

BACK-UP MATERIAL:

Purchase Quote

AGENDA ITEM NO. 11

Authorization of Change Orders

AGENDA ITEM NO. 12

Authorization of Federal and State Grants

AGENDA ITEM NO. 12.1

**Grant Agreement: Authorization to Accept
Federal Grant – Concourse A Modernization**

AGENDA ITEM NO: 12.1
MEETING DATE: August 12, 2024

ALBANY COUNTY AIRPORT AUTHORITY
REQUEST FOR AUTHORIZATION

DEPARTMENT: *Planning and Environmental*

Contact Person: *Connor Haskin, ENV SP, Chief Airport Planner*

PURPOSE OF REQUEST:

Grant Agreement: *Authorization to Accept Federal Grant – Concourse A Modernization*

CONTRACT AMOUNT:

Grant Amount: *\$10,600,000 – FAA
\$10,600,000 – Total*

BUDGET INFORMATION:

Anticipated in Current ALB Capital Plan: Yes ✓ No ___ NA
Funding Account No.: N/A

FISCAL IMPACT - FUNDING (Dollars or Percentages)

Federal: N/A State: N/A Airport: N/A
Term of Funding: 2024 (FAA Fiscal Year)
Federal AIP Grant No.: 3-36-0001-152-2024; NYSDOT Grant Pin No.: N/A;

JUSTIFICATION:

Authorization is requested to accept the awarded federal grant for the Concourse A Modernization Project in the total sum of \$10,600,000. This grant is awarded through the Bipartisan Infrastructure Law funding source for the FAA's Fiscal Year 2024.

AGENDA ITEM NO: 12.1
MEETING DATE: August 12, 2024

PROCUREMENT DEPARTMENT APPROVAL:

Procurement complies with Authority Procurement Guidelines and Chief Financial Officer has approved. YES _____ NA ✓

CHIEF EXECUTIVE OFFICER'S RECOMMENDATION:

Recommend approval.

FINAL AGREEMENT SUBJECT TO APPROVAL BY COUNSEL: YES ✓ NA _____

BACK-UP MATERIAL:

Please refer to the attached final grant application package.



June 27th, 2024
By electronic transmittal

Ms. Evelyn Martinez, Manager
FAA New York Airports District Office
One Aviation Plaza, Suite 111
Jamaica, New York 11434

Subject: Albany International Airport - ALB Terminal A Reconstruction (33,000 SF); New A1 & A2 PBBs; New Companion Restroom Revised Final Grant Application, Bipartisan Infrastructure Law (BIL) Funding

Dear Ms. Martinez:

I would like to cordially submit a revised final grant application for the previously announced BIL funding allotment for our ALB Terminal A Reconstruction (33,000 SF); New A1 & A2 PBBs; New Companion Restroom Project. This submission replaces the June 17th, 2024, package. The total BIL funding allocation of \$10,600,000 will be fully utilized through a total eligible project cost of \$13,708,846. As previously transmitted, we are anticipating commencing construction on these crucial improvements in mid-September following final grant execution. Please advise if there is anything we can provide to expedite the subsequent grant issuance.

Enclosed please find the revised final grant application package. The project cost breakdown and associated application forms have been revised to reflect the attached bid table, associated design services, and anticipated construction inspection services. Please note that the Environmental Categorical Exclusion approval was issued on September 23rd, 2022. Airport Layout Plan and permanent structure airspace reviews were both approved as appropriate.

Thank you for your continued support with our capital improvement projects. Please do not hesitate to call Chief Airport Planner, Connor Haskin, at (518) 242-2239 if you require any additional information.

Sincerely,

Philip F. Calderone

Philip F. Calderone, Esq.,
Chief Executive Officer

cc: Rob Costa, FAA NYADO
Ralph Gatto, FAA NYADO
Christine Quinn, ACAA
Michael F. Zonsius, ACAA
Margaret Herrmann, ACAA
John LaClair, ACAA
Connor Haskin, ACAA

Application for Federal Assistance SF-424

*1. Type of Submission: Preapplication Application Changed/Corrected Application	*2. Type of Application * If Revision, select appropriate letter(s): New Continuation * Other (Specify) Revision
---	---

*3. Date Received: _____ 4. Applicant Identifier: _____

5a. Federal Entity Identifier: _____	5b. Federal Award Identifier: _____
--------------------------------------	-------------------------------------

State Use Only:

6. Date Received by State: _____	7. State Application Identifier: _____
----------------------------------	--

8. APPLICANT INFORMATION:

*a. Legal Name: _____

*b. Employer/Taxpayer Identification Number (EIN/TIN): _____	*c. UEI: _____
--	----------------

d. Address:

*Street 1: _____
Street 2: _____
*City: _____
County/Parish: _____
*State: Province: _____
*Country: _____
*Zip / Postal Code _____

e. Organizational Unit:

Department Name: _____	Division Name: _____
------------------------	----------------------

f. Name and contact information of person to be contacted on matters involving this application:

Prefix: _____ *First Name: _____
Middle Name: _____
*Last Name: _____
Suffix: _____

Title: _____

Organizational Affiliation: _____

*Telephone Number: _____ Fax Number: _____

*Email: _____

Application for Federal Assistance SF-424

***9. Type of Applicant 1: Select Applicant Type:**

Type of Applicant 2: Select Applicant Type:

Type of Applicant 3: Select Applicant Type:

*Other (Specify)

***10. Name of Federal Agency:**

11. Catalog of Federal Domestic Assistance Number:

CFDA Title:

***12. Funding Opportunity Number:**

*Title:

13. Competition Identification Number:

Title:

14. Areas Affected by Project (Cities, Counties, States, etc.):

***15. Descriptive Title of Applicant's Project:**

Attach supporting documents as specified in agency instructions.

Application for Federal Assistance SF-424

16. Congressional Districts Of:

*a. Applicant:

*b. Program/Project:

Attach an additional list of Program/Project Congressional Districts if needed.

17. Proposed Project:

*a. Start Date:

*b. End Date:

18. Estimated Funding (\$):

*a. Federal _____
*b. Applicant _____
*c. State _____
*d. Local _____
*e. Other _____
*f. Program Income _____
*g. TOTAL _____

***19. Is Application Subject to Review By State Under Executive Order 12372 Process?**

- a. This application was made available to the State under the Executive Order 12372 Process for review on _____ .
- b. Program is subject to E.O. 12372 but has not been selected by the State for review.
- c. Program is not covered by E.O. 12372.

***20. Is the Applicant Delinquent On Any Federal Debt?**

Yes No

If "Yes", explain:

21. *By signing this application, I certify (1) to the statements contained in the list of certifications** and (2) that the statements herein are true, complete and accurate to the best of my knowledge. I also provide the required assurances** and agree to comply with any resulting terms if I accept an award. I am aware that any false, fictitious, or fraudulent statements or claims may subject me to criminal, civil, or administrative penalties. (U. S. Code, Title 218, Section 1001)

** I AGREE

** The list of certifications and assurances, or an internet site where you may obtain this list, is contained in the announcement or agency specific instructions.

Authorized Representative:

Prefix: _____ *First Name: _____
Middle Name: _____
*Last Name: _____
Suffix: _____

*Title:

*Telephone Number:

Fax Number:

* Email:

*Signature of Authorized Representative:

*Date Signed:

Application for Federal Assistance (Development and Equipment Projects)

PART II – PROJECT APPROVAL INFORMATION

Part II - SECTION A			
The term "Sponsor" refers to the applicant name provided in box 8 of the associated SF-424 form.			
Item 1. Does Sponsor maintain an active registration in the System for Award Management (www.SAM.gov)?	Yes	No	
Item 2. Can Sponsor commence the work identified in the application in the fiscal year the grant is made or within six months after the grant is made, whichever is later?	Yes	No	N/A
Item 3. Are there any foreseeable events that would delay completion of the project? If yes, provide attachment to this form that lists the events.	Yes	No	N/A
Item 4. Will the project(s) covered by this request have impacts or effects on the environment that require mitigating measures? If yes, attach a summary listing of mitigating measures to this application and identify the name and date of the environmental document(s).	Yes	No	N/A
Item 5. Is the project covered by this request included in an approved Passenger Facility Charge (PFC) application or other Federal assistance program? If yes, please identify other funding sources by checking all applicable boxes. <div style="margin-left: 20px;"> The project is included in an <i>approved</i> PFC application. If included in an approved PFC application, does the application <i>only</i> address AIP matching share? Yes No </div> The project is included in another Federal Assistance program. Its CFDA number is below.	Yes	No	N/A
Item 6. Will the requested Federal assistance include Sponsor indirect costs as described in 2 CFR Appendix VII to Part 200, States and Local Government and Indian Tribe Indirect Cost Proposals? If the request for Federal assistance includes a claim for allowable indirect costs, select the applicable indirect cost rate the Sponsor proposes to apply: <div style="margin-left: 20px;"> De Minimis rate of 10% as permitted by 2 CFR § 200.414. Negotiated Rate equal to % as approved by (the Cognizant Agency) on (Date) (2 CFR part 200, appendix VII). </div> <i>Note: Refer to the instructions for limitations of application associated with claiming Sponsor indirect costs.</i>	Yes	No	N/A

PART II - SECTION B

Certification Regarding Lobbying

The declarations made on this page are under the signature of the authorized representative as identified in box 21 of form SF-424, to which this form is attached. The term "Sponsor" refers to the applicant name provided in box 8 of the associated SF-424 form.

The Authorized Representative certifies, to the best of his or her knowledge and belief, that:

(1) No Federal appropriated funds have been paid or will be paid, by or on behalf of the Sponsor, to any person for influencing or attempting to influence an officer or employee of an agency, a Member of Congress, an officer or employee of Congress, or an employee of a Member of Congress in connection with the awarding of any Federal contract, the making of any Federal grant, the making of any Federal loan, the entering into of any cooperative agreement, and the extension, continuation, renewal, amendment, or modification of any Federal contract, grant, loan, or cooperative agreement.

(2) If any funds other than Federal appropriated funds have been paid or will be paid to any person for influencing or attempting to influence an officer or employee of any agency, a Member of Congress, an officer or employee of Congress, or an employee of a Member of Congress in connection with this Federal contract, grant, loan, or cooperative agreement, the Authorized Representative shall complete and submit Standard Form-LLL, "Disclosure Form to Report Lobbying," in accordance with its instructions.

(3) The Authorized Representative shall require that the language of this certification be included in the award documents for all sub-awards at all tiers (including subcontracts, subgrants, and contracts under grants, loans, and cooperative agreements) and that all subrecipients shall certify and disclose accordingly.

This certification is a material representation of fact upon which reliance was placed when this transaction was made or entered into. Submission of this certification is a prerequisite for making or entering into this transaction imposed by section 1352, title 31, U.S. Code. Any person who fails to file the required certification shall be subject to a civil penalty of not less than \$10,000 and not more than \$100,000 for each such failure.

PART II – SECTION C

The Sponsor hereby represents and certifies as follows:

1. Compatible Land Use – The Sponsor has taken the following actions to assure compatible usage of land adjacent to or in the vicinity of the airport:

2. Defaults – The Sponsor is not in default on any obligation to the United States or any agency of the United States Government relative to the development, operation, or maintenance of any airport, except as stated herewith:

3. Possible Disabilities – There are no facts or circumstances (including the existence of effective or proposed leases, use agreements or other legal instruments affecting use of the Airport or the existence of pending litigation or other legal proceedings) which in reasonable probability might make it impossible for the Sponsor to carry out and complete the Project or carry out the provisions of the Grant Assurances, either by limiting its legal or financial ability or otherwise, except as follows:

4. Consistency with Local Plans – The project is reasonably consistent with plans existing at the time of submission of this application) of public agencies that are authorized by the State in which the project is located to plan for the development of the area surrounding the airport.

5. Consideration of Local Interest – It has given fair consideration to the interest of communities in or near where the project may be located.

6. Consultation with Users – In making a decision to undertake an airport development project under Title 49, United States Code, it has consulted with airport users that will potentially be affected by the project (§ 47105(a)(2)).

7. Public Hearings – In projects involving the location of an airport, an airport runway or a major runway extension, it has afforded the opportunity for public hearings for the purpose of considering the economic, social, and environmental effects of the airport or runway location and its consistency with goals and objectives of such planning as has been carried out by the community and it shall, when requested by the Secretary, submit a copy of the transcript of such hearings to the Secretary. Further, for such projects, it has on its management board either voting representation from the communities where the project is located or has advised the communities that they have the right to petition the Secretary concerning a proposed project.

8. Air and Water Quality Standards – In projects involving airport location, a major runway extension, or runway location it will provide for the Governor of the state in which the project is located to certify in writing to the Secretary that the project will be located, designed, constructed, and operated so as to comply with applicable and air and water quality standards. In any case where such standards have not been approved and where applicable air and water quality standards have been promulgated by the Administrator of the Environmental Protection Agency, certification shall be obtained from such Administrator. Notice of certification or refusal to certify shall be provided within sixty days after the project application has been received by the Secretary.

PART II – SECTION C (Continued)

9. Exclusive Rights – There is no grant of an exclusive right for the conduct of any aeronautical activity at any airport owned or controlled by the Sponsor except as follows:

10. Land – (a) The sponsor holds the following property interest in the following areas of land, which are to be developed or used as part of or in connection with the Airport subject to the following exceptions, encumbrances, and adverse interests, all of which areas are identified on the aforementioned property map designated as Exhibit “A”. [1]

The Sponsor further certifies that the above is based on a title examination by a qualified attorney or title company and that such attorney or title company has determined that the Sponsor holds the above property interests.

(b) The Sponsor will acquire within a reasonable time, but in any event prior to the start of any construction work under the Project, the following property interest in the following areas of land on which such construction work is to be performed, all of which areas are identified on the aforementioned property map designated as Exhibit “A”. [1]

(c) The Sponsor will acquire within a reasonable time, and if feasible prior to the completion of all construction work under the Project, the following property interest in the following areas of land which are to be developed or used as part of or in connection with the Airport as it will be upon completion of the Project, all of which areas are identified on the aforementioned property map designated as Exhibit “A”. [1]

¹ State the character of property interest in each area and list and identify for each all exceptions, encumbrances, and adverse interests of every kind and nature, including liens, easements, leases, etc. The separate areas of land need only be identified here by the area numbers shown on the property map.

PART III – BUDGET INFORMATION – CONSTRUCTION

SECTION A – GENERAL
1. Assistance Listing Number:
2. Functional or Other Breakout:

SECTION B – CALCULATION OF FEDERAL GRANT			
Cost Classification	Latest Approved Amount (Use only for revisions)	Adjustment + or (-) Amount (Use only for revisions)	Total Amount Required
1. Administration expense			
2. Preliminary expense			
3. Land, structures, right-of-way			
4. Architectural engineering basic fees			
5. Other Architectural engineering fees			
6. Project inspection fees			
7. Land development			
8. Relocation Expenses			
9. Relocation payments to Individuals and Businesses			
10. Demolition and removal			
11. Construction and project improvement			
12. Equipment			
13. Miscellaneous			
14. Subtotal (Lines 1 through 13)			
15. Estimated Income (if applicable)			
16. Net Project Amount (Line 14 minus 15)			
17. Less: Ineligible Exclusions (Section C, line 23 g.)			
18. Subtotal (Lines 16 through 17)			
19. Federal Share requested of Line 18			
20. Grantee share			
21. Other shares			
22. TOTAL PROJECT (Lines 19, 20 & 21)			

SECTION C – EXCLUSIONS	
23. Classification (Description of non-participating work)	Amount Ineligible for Participation
a.	
b.	
c.	
d.	
e.	
f.	
g. Total	

SECTION D – PROPOSED METHOD OF FINANCING NON-FEDERAL SHARE	
24. Grantee Share – Fund Categories	Amount
a. Securities	
b. Mortgages	
c. Appropriations (by Applicant)	
d. Bonds	
e. Tax Levies	
f. Non-Cash	
g. Other (Explain):	
h. TOTAL - Grantee share	
25. Other Shares	Amount
a. State	
b. Other	
c. TOTAL - Other Shares	
26. TOTAL NON-FEDERAL FINANCING	

SECTION E – REMARKS (Attach sheets if additional space is required)

PART IV – PROGRAM NARRATIVE
(Suggested Format)

PROJECT:
AIRPORT:
1. Objective:
2. Benefits Anticipated:
3. Approach: (See approved Scope of Work in Final Application)
4. Geographic Location:
5. If Applicable, Provide Additional Information:
6. Sponsor's Representative: (include address & telephone number)

Albany International Airport
 ALB Terminal A Reconstruction (33,000 SF); New A1 & A2 PBBs; New Companion Restroom
 BIL ATP

PROJECT COST BREAKDOWN												
Item	Description		Work Code / NPR	Admin Cost	Engineering	Inspection	Construction	Total Cost	% Eligible	BIL ATP	Local Share	Local Remaining
										95%	5%	
1	Reconstruct Terminal Building	Reconstruct 33,000 Square Feet of existing Terminal A Level 1 and Level 2 Building Space at 90.1% eligibility- Reconstruct existing Concourse Area, Holdrooms, Seating Areas, Gate Areas, and Construct One new ADA accessible Companion Restroom– Design and Construction	RC TE IM / 49	\$0.00	\$1,195,363.00	\$0.00	\$10,582,010.00	\$11,777,373.00	90.1%	\$8,605,000.00	\$530,570.65	\$2,641,802.35
2	New A1 & A2 Passenger Boarding Bridge	Acquire and Install Two new Passenger Boarding Bridges to Accommodate More Aircraft Operations at 100% Eligibility. – Construction	CA TE IN / 52	\$0.00	\$0.00	\$0.00	\$2,100,000.00	\$2,100,000.00	100%	\$1,995,000.00	\$105,000.00	\$0.00
Total				\$0.00	\$1,195,363.00	\$0.00	\$12,682,010.00	\$13,877,373.00		\$10,600,000.00	\$635,570.65	\$2,641,802.35

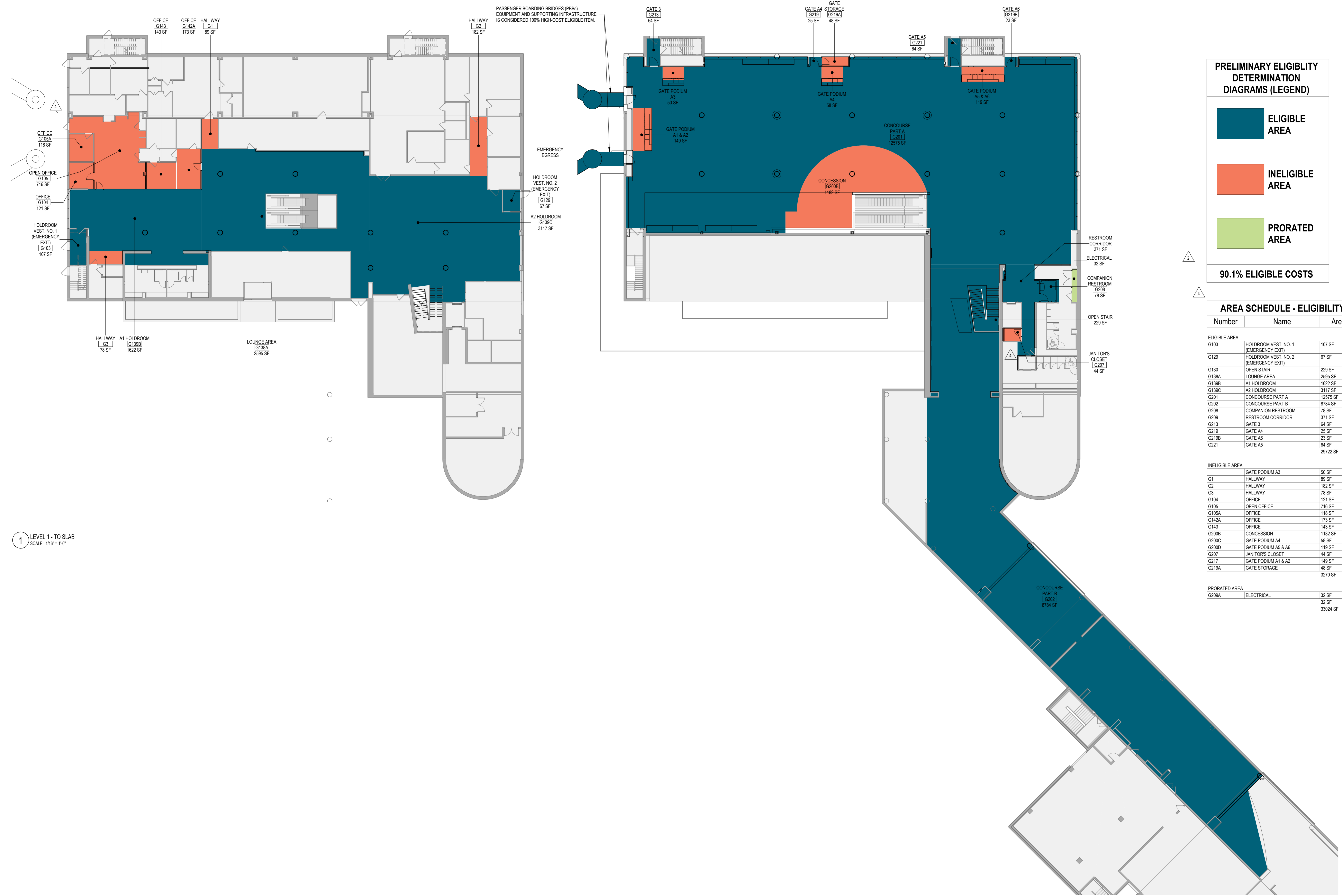

**PRELIMINARY ELIGIBILITY
DETERMINATION
DIAGRAMS (LEGEND)**

- ELIGIBLE AREA
- INELIGIBLE AREA
- PRORATED AREA

90.1% ELIGIBLE COSTS

AREA SCHEDULE - ELIGIBILITY

Number	Name	Area
ELIGIBLE AREA		
G103	HOLDROOM VEST. NO. 1 (EMERGENCY EXIT)	107 SF
G129	HOLDROOM VEST. NO. 2 (EMERGENCY EXIT)	67 SF
G130	OPEN STAIR	229 SF
G138A	LOUNGE AREA	2595 SF
G139B	A1 HOLDROOM	1622 SF
G139C	A2 HOLDROOM	3117 SF
G201	CONCOURSE PART A	12375 SF
G202	CONCOURSE PART B	9784 SF
G208	COMPANION RESTROOM	78 SF
G209	RESTROOM CORRIDOR	371 SF
G213	GATE 3	64 SF
G219	GATE A4	25 SF
G219B	GATE A6	23 SF
G221	GATE A5	64 SF
		29722 SF
INELIGIBLE AREA		
	GATE PODIUM A3	50 SF
G1	HALLWAY	89 SF
G2	HALLWAY	182 SF
G3	HALLWAY	78 SF
G104	OFFICE	121 SF
G105	OPEN OFFICE	716 SF
G105A	OFFICE	118 SF
G142A	OFFICE	173 SF
G143	OFFICE	143 SF
G200B	CONCESSION	1162 SF
G200C	GATE PODIUM A4	58 SF
G200D	GATE PODIUM A5 & A6	119 SF
G207	JANITOR'S CLOSET	44 SF
G217	GATE PODIUM A1 & A2	149 SF
G219A	GATE STORAGE	48 SF
		3270 SF
PRORATED AREA		
G209A	ELECTRICAL	32 SF
		33024 SF

1 LEVEL 1 - TO SLAB
SCALE: 1/16" = 1'-0"

2 LEVEL 2 - TO SLAB - AREA PLAN
SCALE: 1/16" = 1'-0"

Memorandum

Date: June 7, 2024
To: Phil Calderone, Chief Executive Officer
Affiliation: Albany County Airport Authority
From: Melissa Vaillancourt
Project: Concourse A Rehabilitation
Project No: FM No. 1236, ACCA Bid No. 1127

Subject: Contractor Recommendation

Dear Mr. Calderone,

On May 29, 2024 at 10am, bids were opened for the Concourse A Renovations. Four bids were received, each including the base bid cost and values for five add alternates as requested. Turner Construction Company organized prepared the Bid Tabulation and provided the compiled bid tab to FM. the Bid Results and provided a compiled bid tabulation to FM, referenced below. The apparent low bidder is **AOW**.

A Cost Estimate of approximately **\$17,905,000** included the cost the Base Bid and Alternates 1, 3, 4 and 5. We note that the cost of Alternate 2 (Fire Watch) was not included in cost estimating but was requested in bidding.

Bid Results:

	AOW	VMJR	VRH	MURNAME
Base Bid	\$12,206,800.00	\$13,900,000.00	\$14,236,000.00	\$15,241,900.00
Alt 1 (L. Level Improv's)	\$404,113.00	\$535,000.00	\$470,000.00	\$540,800.00
Alt 2 (24/7 Fire Watch)	\$123,833.00	\$40,000.00	\$178,000.00	\$944,000.00
Alt 3 (Cpt & ACT at Concess)	\$51,777.00	\$41,000.00	\$82,400.00	\$59,900.00
Alt 4 (Wood Baffle Ceilings)	\$444,492.00	\$535,000.00	\$730,200.00	\$374,900.00
Alt 5 (Arm Rests at Zenky)	\$30,718.00	\$30,000.00	\$45,000.00	\$62,800.00
Total	\$13,261,733.00	\$15,081,000.00	\$15,741,600.00	\$17,224,300.00
<i>Base + Alternates 3, 4 & 5 (per TCCO Bid Tab Summary)</i>	\$12,733,787.00	\$14,506,000.00	\$15,093,600.00	\$15,739,500.00
<i>Base + Alternates 1, 3, 4 & 5 (to compare with estimate)</i>	\$13,137,900.00	\$15,041,000.00	\$15,563,600.00	\$16,280,300.00

All four bidders noted receipt of all six addenda issued during bidding. It is our understanding that selection of Alternates has not been finalized, the summarized bid results include all base bids, alternates and selected combined values pending final decision by the ACAA.

Turner Construction Company has been leading outreach and communication with the apparent low bidder. The design team and TCCO reviewed the scope on 6/7/24. FM did not perform reference checks, but notes that TCCO and ACCA both have prior experience with AOW.

Recommendation:

Based on the bid documentation provided to FM and information provided by TCCO, the requirements of New York State and applicable Federal requirements, FM recommends award of the contract to AOW as the responsible low bidder.

If you have any questions or require additional information, please contact me at your convenience.

Thank you,

A handwritten signature in blue ink, appearing to read 'Melissa Vaillancourt', with a long horizontal flourish extending to the right.

Melissa Vaillancourt, AIA
Project Manager

FM Architecture



June 27th, 2024
By electronic transmittal

Mr. Ralph Gatto, Airport Engineer
FAA New York Airports District Office
One Aviation Plaza, Suite 111
Jamaica, New York 11434

Re: Concurrence in Award Request: ALB Terminal A Reconstruction (33,000 SF); New A1 & A2 PBBs; New Companion Restroom: Contract 1127-GC Bid Package

Dear Mr. Gatto:

I am writing to respectfully request concurrence in award for the above BIL-ATP funded construction Contract 1127-GC to AOW with the following accepted bid pricing:

- Lump Sum Bid: \$12,206,800.00
- Alternative 3: \$51,777.00 (*Ineligible for Federal Funding*)
- Alternative 4: \$444,492.00
- Alternative 5: \$30,718.00
 - **Total Accepted Bid: \$12,733,787**

Enclosed please find the certified bid tab, plan holders list, and pre-bid attendance list for your reference.

Please extend our gratitude to your staff for the excellent assistance associated with our capital improvement projects. Please do not hesitate to call Connor Haskin on my staff at (518) 242-2239 if you require any additional information or assistance.

Sincerely,

Philip F. Calderone

Philip F. Calderone, Esq.,
Chief Executive Officer

cc: Rob Costa, FAA NYADO
Christine Quinn, ACAA
Michael Zonsius, ACAA
John LaClair, ACAA
Margaret Herrmann, ACAA
Connor Haskin, ACAA

CONTRACT #1127-GC
Rehabilitation of Concourse A

Company Name	VMJR Companies	VRH Construction	AOW Construction	Murnane Building Contractors
Addendums #1-7	X	X	X	X
Lump Sum Bid	\$13,900,000.00	\$14,236,000.00	\$12,206,800.00	\$15,241,900.00
Add Alternate 01	\$535,000.00	\$470,000.00	\$404,113.00	\$540,800.00
Add Alternate 02	\$40,000.00	\$178,000.00	\$123,833.00	\$944,000.00
Add Alternate 03	\$41,000.00	\$82,400.00	\$51,777.00	\$59,900.00
Add Alternate 04	\$535,000.00	\$730,200.00	\$444,492.00	\$374,900.00
Add Alternate 05	\$30,000.00	\$45,000.00	\$30,718.00	\$62,800.00
Bid Bond	5%	5%	5%	5%
Board of Directors	X	X	X	X
Non-Collusion	X	X	X	X
Qualification Questionnaire	X	X	X	X
Acknowledgment	X	X	X	X

I, Bobbi Matthews, certify that this bid tabulation is a true copy of the prices submitted by each bidder for the construction project shown above.

Albany Airport Authority Purchasing Department

Bobbi Matthews
 Bobbi Matthews
 Purchasing Agent

Sworn to before me this 30th day of May 2021

Jennifer A. Munger
 Notary Public

JENNIFER A. MUNGER
 Notary Public, State of New York
 No. 01MU6246332
 Qualified in Schenectady County
 Commission Expires Aug. 08, 2027



1910

Faint, illegible text, possibly bleed-through from the reverse side of the page.

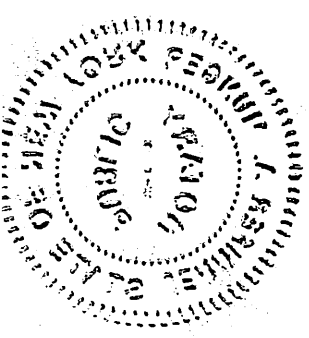

Solicitation Document Report

Report Executed By Kathryn Kane
 Report Executed On 2024/05/29 09.13.11
 Project 1127-GC - Concourse A Rehabilitation
 Suppliers Suppliers who have downloaded a document

Supplier Organization				Main Contact			Organization Downloads	Contact			Project	Amendment		
Name	Address	City	State/Prov	Name	Phone	Email		Name	Phone	Email	Document	Download Date	Document	Download Date
ABP Construction	578 Nepperhan Ave Suite 504	Yonkers	NY	Abbigayle Beake	9144144199	info@abp-consult.com	Partial 1/45	Abbigayle Beake	9144144199	info@abp-consult.com	Rehabilitation on Concourse A.pdf	2024/04/23		
AERO BridgeWorks	2700 Delk Rd SE, Suite 150	Marietta	GA	Rob Brethauer	7704234200	rob.brethauer@aerosys.net	Partial 20/45	Rob Brethauer	7704234200	rob.brethauer@aerosys.net	2024.04.10 100% CD Drawings.pdf	2024/05/21	1127-GC Addendum #3 Prebid-RFI-002 GC R.pdf	2024/05/21
											1127 GC Legal Notice.pdf	2024/05/21	1127-GC Addendum #4 2024.05.08 Architectural Drawings Addendum 03.pdf	2024/05/21
											Rehabilitation on Concourse A.pdf	2024/05/21	1127-GC Addendum #3 2024. Architectural Drawing A441 Addendum 03.pdf	2024/05/21
													1127-GC Addendum #3 Prebid-RFI-003 GC R.pdf	2024/05/21
													1127-GC Addendum 2- PREBID-RFI-001 GC R.pdf	2024/05/21
													1127-GC Addendum 02 Cover Sheet.pdf	2024/05/21
													1127-GC Pre Bid Meeting Agenda Final.pdf	2024/05/21
													1127-GC Addendum #4 2024.04.08 Mechanical Drawings Addendum 03.pdf	2024/05/21
													1127-GC Addendum #4 FAA Form 5100 136 Buy American Worksheet.pdf	2024/05/21
													1127-GC Addendum #3 Cover Sheet.pdf	2024/05/21
													1127-GC Addendum #3 Prebid-RFI-005 GC R.pdf	2024/05/21
													1127-GC Addendum 2- 2024.04.30 Civil Drawings.pdf	2024/05/21
													1127-GC Addendum #3 Prebid-RFI-004 GC R.pdf	2024/05/21
													1127-GC Addendum #3 23.0014 - Albany Airport Terminal A_RGE_Geotech Report.pdf	2024/05/21

AOW Construction, LLC	30 Essex Street	Albany	NY	Jim Umer	518-482-3400	bid@aowconstruction.com	Full 45/45	Jim Umer	518-482-3400	bid@aowconstruction.com	Rehabilitation on Concourse A.pdf	2024/04/25	1127-GC Addendum 2-2024.04.30 Architectural Drawings.pdf	2024/05/21
											1127-GC Pre-bid Attendees.pdf	2024/05/21		
											1127-GC Addendum #1 cover sheet.pdf	2024/05/21		
											1127-GC Pre Bid Meeting Agenda Final.pdf	2024/04/30		
											1127 GC Legal Notice.pdf	2024/04/25	1127-GC Addendum #3 Prebid-RFI-005 GC R.pdf	2024/05/09
											2024.04.10 100% CD Drawings.pdf	2024/04/25	1127-gc Prebid-RFI-006 GC [R] (1).pdf	2024/05/21
													1127-gc Addendum 07 Door Hardware.pdf	2024/05/28
													1127-gc Addendum 07 Cover Sheet.pdf	2024/05/28
													1127-gc Addendum 07 Cover Sheet.pdf	2024/05/28
													1127-GC Addendum 2- PREBID-RFI-001 GC R.pdf	2024/04/30
													1127-gc Addendum 07 Architectural Drawings.pdf	2024/05/28
													1127-gc Addendum 05 Electrical Drawings.pdf	2024/05/21
													1127-GC Addendum 07 Bid Form R2.pdf	2024/05/28
													1127-GC Addendum #3 Prebid-RFI-002 GC R.pdf	2024/05/09
													1127-GC Addendum #4 2024.04.08 Mechanical Drawings Addendum 03.pdf	2024/05/09
													1127-gc Prebid-RFI-011R1 GC [R].pdf	2024/05/21
													1127-gc Terminal A Pay Schedule Of Values (Sample).pdf	2024/05/21
													1127-GC Addendum #3 Prebid-RFI-004 GC R.pdf	2024/05/09
													1127-gc Addendum 05 Cover Sheet.pdf	2024/05/21
													1127-gc Addendum 05 Cover Sheet.pdf	2024/05/22
													11270gc Addendum 07 Prebid-RFI-012 GC [R].pdf	2024/05/28
													1127-GC Addendum 2-2024.04.30 Civil Drawings.pdf	2024/04/30
													1127-GC Addendum #3 23.0014 - Albany Airport Terminal	2024/05/09

Name	Address	City	State/Prov	Name	Phone	Email		Name	Phone	Email	Document	Download Date	Download Date
AOW Construction, LLC	30 Essex Street	Albany	NY	Jim Urner	518-482-3400	bid@aowconstruction.com	Full 45/45	Jim Urner	518-482-3400	bid@aowconstruction.com	A_RGE_Geotech Report.pdf	2024/05/09	
											1127-GC Addendum #4 FAA Form 5100 136 Buy American Worksheet.pdf	2024/05/28	
											1127-gc Addendum 07 Prebid-RFI-015 GC [R].pdf	2024/05/09	
											1127-GC Addendum #3 Cover Sheet.pdf	2024/05/21	
											1127-gc Prebid-RFI-007 GC [R] (1).pdf	2024/05/22	
											1127-GC Addendum 06 drawings.pdf	2024/05/09	
											1127-GC Addendum #3 2024. Architectural Drawing A441 Addendum 03.pdf	2024/05/21	
											1127-gc Prebid-RFI-010 GC [R].pdf	2024/05/28	
											1127-gc Addendum 07 Prebid-RFI-013 GC [R].pdf	2024/05/21	
											1127 GC Addendum 06 cover sheet.pdf	2024/05/22	
											1127-gc Addendum 05 Structural Drawings.pdf	2024/05/09	
											1127-GC Addendum #4 2024.05.08 Architectural Drawings Addendum 03.pdf	2024/05/21	
											1127-gc Addendum 05 28 2000 BSD-Video Surveillance.pdf	2024/04/30	
											1127-GC Addendum #1 cover sheet.pdf	2024/05/21	
											1127-gc Addendum 05 28 1000 BSD-Access Control.pdf	2024/04/30	
											1127-GC Addendum 2-2024.04.30 Architectural Drawings.pdf	2024/05/09	
											1127-GC Addendum #3 Prebid-RFI-003 GC R.pdf	2024/05/22	
											1127 gc Addendum 06.pdf	2024/04/30	
											1127-GC Pre-bid Attendees.pdf	2024/04/30	
											1127-GC Addendum 02 Cover Sheet.pdf	2024/05/21	
											1127-gc addAddendum 05 26 2726 BSD-		

Access Anvil Corp.	109 General Fellows Rd.	Greenwich	NY	Jennifer Wilcox	5183830500	jwilcox@accessanvil.com	Partial 1045	Jennifer Wilcox	5183830500	jwilcox@accessanvil.com	1127 GC Legal Notice.pdf 2024.04.10 100% CD Drawings.pdf	2024/05/01	2024/05/01	2024/05/01	Writing Devices.pdf 1127-jc Prebid-RFI-008 GC R].pdf 1127-gc Addendum 05 Drawings.pdf 1127-gc Addendum 07 Prebid-RFI-014 GC R].pdf 1127-GC Addendum #1 cover sheet.pdf 1127-GC Addendum 2-2024.04.30 Architectural Drawings.pdf	2024/05/21	2024/05/21	2024/05/28	
Advanced Network Services	12 Elmwood Ave	Albany	NY	Joel Stuart	518-441-9343	jstuart@anscorporate.com	Partial 2045	Joel Stuart	518-441-9343	jstuart@anscorporate.com	Rehabilitation on Concourse A.pdf 2024.04.10 100% CD Drawings.pdf	2024/04/18	2024/04/25	2024/04/25	1127-GC Addendum 2- PREBID-RFI-001 GC R].pdf 1127-GC Addendum 2- PREBID-RFI-001 GC R].pdf 1127-GC Addendum 2- Addendum 02 Cover Sheet.pdf 1127-GC Pre Bid Meeting Agenda Final.pdf 1127-GC Pre-bid Attendees.pdf 1127-GC Addendum 2- PREBID-RFI-001 GC R].pdf 1127-GC Addendum 2- Addendum 2- Drawings.pdf	2024/05/01	2024/05/01	2024/05/01	2024/05/01
											Rehabilitation on Concourse A.pdf	2024/04/18	2024/04/25	2024/04/25	1127-GC Addendum 2- PREBID-RFI-001 GC R].pdf 1127-GC Addendum 2- Addendum 02 Cover Sheet.pdf 1127-GC Pre Bid Meeting Agenda Final.pdf 1127-GC Pre-bid Attendees.pdf 1127-GC Addendum 2- PREBID-RFI-001 GC R].pdf 1127-GC Addendum 2- Addendum 2- Drawings.pdf	2024/05/09	2024/04/25	2024/05/09	2024/05/09
											2024.04.10 100% CD Drawings.pdf	2024/04/18	2024/04/25	2024/04/25	1127-GC Addendum #4 FAA Form 5100 136 Buy American Worksheet.pdf 1127-GC Addendum #4 2024.04.08 Mechanical Drawings Addendum 03.pdf	2024/05/09	2024/05/09	2024/05/09	2024/05/09
											1127 GC Legal Notice.pdf	2024/04/18	2024/04/25	2024/04/25	1127-GC Addendum #3 23.0014 - Albany Airport Terminal A_RGE_Geotech Report.pdf 1127-GC Addendum #3 Architectural Drawing A441 Addendum 03.pdf	2024/05/09	2024/05/09	2024/05/09	2024/05/09
											1127 GC Legal Notice.pdf	2024/04/25	2024/04/25	2024/04/25	1127-GC Addendum #3 2024.04.30 Civil Drawings.pdf 1127-GC Addendum #3 Cover Sheet.pdf 1127-GC Addendum #3 Prebid-RFI-005 GC R].pdf	2024/05/09	2024/05/09	2024/05/09	2024/05/09
											1127 GC Legal Notice.pdf	2024/04/25	2024/04/25	2024/04/25	1127-GC Addendum #3 2024.04.30 Civil Drawings.pdf 1127-GC Addendum #3 Cover Sheet.pdf 1127-GC Addendum #3 Prebid-RFI-004 GC R].pdf	2024/05/09	2024/05/09	2024/05/09	2024/05/09

												1127-GC Pre-bid Attendees.pdf	2024/04/25	
												1127-GC Pre-bid Attendees.pdf	2024/04/25	
												1127-GC Addendum #3 Prebid-RFI-002 GC R.pdf	2024/05/09	
												1127-GC Addendum #3 Prebid-RFI-003 GC R.pdf	2024/05/09	
												1127-GC Addendum #4 2024.05.08 Architectural Drawings Addendum 03.pdf	2024/05/09	
												1127-GC Addendum 2-2024.04.30 Architectural Drawings.pdf	2024/05/09	
												1127-GC Addendum 02 Cover Sheet.pdf	2024/05/09	
												1127-GC Pre Bid Meeting Agenda Final.pdf	2024/04/25	
Aero Systems Engineering	2700 Delk Road SE, Suite 100	Marietta	GA	Rob Brethauer	7704234200	rob.brethauer@aerosys.net	Partial 3/45	Rob Brothauer	7704234200	rob.brethauer@aerosys.net	Rehabilitation on Concourse A.pdf	2024/05/21		
											2024.04.10 100% CD Drawings.pdf	2024/05/21		
											1127 GC Legal Notice.pdf	2024/05/21		
BW Electrical Services, LLC	12 Elmwood Road	Albany	NY	Franco Fettuccia	5183206047	ffettuccia@bwes.com	Partial 43/45	Franco Fettuccia	5183206047	ffettuccia@bwes.com	1127 GC Legal Notice.pdf	2024/04/25	1127-gc Addendum 05 Cover Sheet.pdf	2024/05/21
											Rehabilitation on Concourse A.pdf	2024/04/25	1127-gc Terminal A Pay Schedule Of Values (Sample).pdf	2024/05/21
											2024.04.10 100% CD Drawings.pdf	2024/04/25	1127-gc Addendum 07 Prebid-RFI-014 GC [R].pdf	2024/05/24
												1127-gc Prebid-RFI-008 GC [R].pdf	2024/05/21	
												1127-gc Addendum 05 Electrical Drawings.pdf	2024/05/21	
												1127-GC Pre-bid Attendees.pdf	2024/04/25	
												1127-GC Pre-bid Attendees.pdf	2024/04/26	
												1127-GC Pre Bid Meeting Agenda Final.pdf	2024/04/25	
												1127-GC Addendum #3 Prebid-RFI-004 GC R.pdf	2024/05/09	
												1127-gc Addendum 07 Prebid-RFI-013 GC [R].pdf	2024/05/24	
Name	Address	City	State/Prov	Name	Phone	Email		Name	Phone	Email	Document	Download Date	Download Date	
BW Electrical Services, LLC	12 Elmwood Road	Albany	NY	Franco Fettuccia	5183206047	ffettuccia@bwes.com	Partial 43/45	Franco Fettuccia	5183206047	ffettuccia@bwes.com	Document 1127-GC Addendum #3 Cover Sheet.pdf	2024/05/09	2024/05/09	
											1127-GC Addendum 06 drawings.pdf		2024/05/23	
											1127-gc Addendum 07 Door Hardware.pdf		2024/05/24	

1127-GC Addendum #3 Prebid-RFI-002 GC R.pdf	2024/05/09
1127-GC Addendum 2- 2024.04.30 Architectural Drawings.pdf	2024/04/30
1127 gc Addendum 06.pdf	2024/05/23
1127-gc Prebid- RFI-011R1 GC [R].pdf	2024/05/21
1127-GC Addendum #3 2024. Architectural Drawing A441 Addendum 03.pdf	2024/05/09
1127-gc Addendum 07 Prebid-RFI-015 GC [R].pdf	2024/05/24
1127-GC Addendum #4 2024.04.08 Mechanical Drawings Addendum 03.pdf	2024/05/09
1127-GC Addendum #1 cover sheet.pdf	2024/04/25
1127-GC Addendum #1 cover sheet.pdf	2024/04/25
1127-GC Addendum 02 Cover Sheet.pdf	2024/04/30
1127-gc Prebid- RFI-007 GC [R] (1).pdf	2024/05/21
1127-GC Addendum #3 Prebid-RFI-003 GC R.pdf	2024/05/09
1127-gc Addendum 05 28 2000 BSD-Video Surveillance.pdf	2024/05/21
1127-gc Addendum 07 Architectural Drawings.pdf	2024/05/24
1127-gc Prebid- RFI-010 GC [R].pdf	2024/05/21
1127-GC Addendum 2- 2024.04.30 Civil Drawings.pdf	2024/04/30
1127-GC Addendum #3 Prebid-RFI-005 GC R.pdf	2024/05/09
1127-GC Addendum 07 Bid Form R2.pdf	2024/05/24
1127-GC Addendum #3 23.0014 - Albany Airport Terminal A_RGE_Geotech Report.pdf	2024/05/09
1127-gc Addendum 07 Cover Sheet.pdf	2024/05/24
1127-GC Addendum #4 2024.05.08 Architectural Drawings Addendum 03.pdf	2024/05/09

Blast Deflectors Inc 8620 TECHNOLOGY WAY RENO NV Matthew Anzai 7754330236 manzai@bdi.aero Partial 31/45 Andy Solsvig 7758561928 asolsvig@bdi.aero

1127-gc Prebid-RFI-009R1 GC [R].pdf 2024/05/21
 11270gc Addendum 07 Prebid-RFI-012 GC [R].pdf 2024/05/24
 1127-GC Addendum #4 FAA Form 5100 136 Buy American Worksheet.pdf 2024/05/09
 1127 GC Addendum 06 cover sheet.pdf 2024/05/23
 1127-gc addAddendum 05 28 2726 BSD-Wiring Devices.pdf 2024/05/21
 1127-gc Addendum 05 28 1000 BSD-Access Control.pdf 2024/04/30
 1127-GC Addendum 2- PREBID-RFI-001 GC R.pdf 2024/05/21
 1127-gc Prebid-RFI-006 GC [R] (1).pdf 2024/05/22
 1127 gc Addendum 06.pdf 2024/05/22
 1127 gc Addendum 06.pdf 2024/05/24
 1127-gc Addendum 07 Prebid-RFI-015 GC [R].pdf 2024/05/22
 1127 GC Addendum 06 cover sheet.pdf 2024/05/13
 1127-GC Addendum #4 FAA Form 5100 136 Buy American Worksheet.pdf 2024/05/17
 1127-GC Addendum #4 FAA Form 5100 136 Buy American Worksheet.pdf 2024/05/22
 1127-gc Terminal A Pay Schedule Of Values (Sample).pdf 2024/05/22
 1127-gc Addendum 05 Civil Drawings.pdf 2024/05/24
 1127-gc Addendum 07 Prebid-RFI-014 GC [R].pdf 2024/05/24
 1127-gc Addendum 07 Cover Sheet.pdf 2024/05/17
 1127-GC Addendum #4 2024.05.08 Architectural Drawings Addendum 03.pdf 2024/05/17
 1127-GC Addendum #3 23.0014 - Albany Airport Terminal A_RGE_Geotech Report.pdf

Name: Blast Deflectors Inc
 Address: 8620 TECHNOLOGY WAY
 City: RENO
 State/Prov: NV
 Name: Matthew Anzai
 Phone: 7754330236
 Email: manzai@bdi.aero

Partial 31/45
 Name: Matthew Anzai
 Phone: 7754330236
 Email: manzai@bdi.aero

Document	Download Date	Document	Download Date
		1127-GC Addendum #3 23.0014 - Albany Airport Terminal A_RGE_Geotech Report.pdf	2024/05/22
		1127-GC Addendum #4 2024.04.08 Mechanical Drawings Addendum 03.pdf	2024/05/17
		1127-GC Addendum 06 drawings.pdf	2024/05/22
		1127-gc Addendum 05 28 1000 BSD-Access Control.pdf	2024/05/22
		1127-GC Pre-bid Attendees.pdf	2024/05/13
		1127-gc Addendum 05 Cover Sheet.pdf	2024/05/22
		1127-gc Prebid-RFI-010 GC [R].pdf	2024/05/22
1127 GC Legal Notice.pdf	2024/04/26	1127-GC Addendum #3 Prebid-RFI-003 GC R.pdf	2024/05/09
Rehabilitation on Concourse A.pdf	2024/04/26	1127-GC Addendum #3 Prebid-RFI-004 GC R.pdf	2024/05/09
2024.04.10 100% CD Drawings.pdf	2024/04/26	1127-GC Addendum #3 2024. Architectural Drawing A441 Addendum 03.pdf	2024/05/09
		1127-GC Addendum #4 FAA Form 5100 136 Buy American Worksheet.pdf	2024/05/09
		1127-GC Addendum #4 FAA Form 5100 136 Buy American Worksheet.pdf	2024/05/09
		1127-GC Addendum 2- PREBID-RFI-001 GC R.pdf	2024/05/09
		1127-GC Addendum #3 Prebid-RFI-005 GC R.pdf	2024/05/09
		1127-GC Addendum 02 Cover Sheet.pdf	2024/05/09
		1127-GC Pre Bid Meeting Agenda Final.pdf	2024/04/26
		1127-GC Pre Bid Meeting Agenda Final.pdf	2024/04/26
		1127-GC Pre Bid Meeting Agenda Final.pdf	2024/05/09
		1127-GC Addendum 2- 2024.04.30 Civil Drawings.pdf	2024/05/09
		1127-GC Addendum #4 2024.04.08 Mechanical	2024/05/09

Cover Sheet.pdf	2024/05/28
1127-gc	
Addendum 07	
Prebid-RFI-013	
GC [R].pdf	
1127-GC	2024/05/28
Addendum 2-	
PREBID-RFI-001	
GC R.pdf	
1127-GC	2024/05/28
Addendum 2-	
2024.04.30	
Architectural	
Drawings.pdf	
1127-GC	2024/05/28
Addendum #4	
2024.04.08	
Mechanical	
Drawings	
Addendum	
03.pdf	
1127-GC	2024/05/28
Addendum #3	
Prebid-RFI-003	
GC R.pdf	
1127-GC	2024/05/28
Addendum 02	
Cover Sheet.pdf	
1127-GC	2024/05/28
Addendum 07	
Bid Form R2.pdf	
1127-gc	2024/05/28
Prebid-RFI-014	
GC [R].pdf	
1127-GC	2024/05/28
Addendum #3	
Prebid-RFI-004	
GC R.pdf	
1127-gc	2024/05/28
Addendum 05	
Structural	
Drawings.pdf	
1127-GC	2024/05/28
Addendum #3	
Prebid-RFI-005	
GC R.pdf	
1127-gc	2024/05/28
Prebid-RFI-010	
GC [R].pdf	
1127-gc	2024/05/28
Addendum 05	
Civil	
Drawings.pdf	
1127Gc	2024/05/28
Addendum 07	
Prebid-RFI-012	
GC [R].pdf	
1127-gc	2024/05/28
Addendum 07	
Architectural	
Drawings.pdf	
1127-GC Pre-bid	2024/05/28
Attendees.pdf	
1127 gc	2024/05/28
Addendum	
06.pdf	
1127-gc	2024/05/28
Addendum 05 28	
2000 BSD-Video	
Surveillance.pdf	
1127-gc	2024/05/28
Addendum 05	
Electrical	
Drawings.pdf	
1127-gc Terminal	2024/05/28
A Pay Schedule	
OI Values	
(Sample).pdf	
1127-GC	2024/05/28
Addendum #3	
Prebid-RFI-002	
GC R.pdf	
1127-GC	2024/05/28
Addendum #4	
FAA Form 5100	
138 Buy	

Name	Address	City	State/Prov	Name	Phone	Email		Name	Phone	Email	Document	Download Date	Document	Download Date
Callanan Industries	8 Southwoods Blvd., 4th Floor, P.O. Box 15097	Albany	NY	Zach Hewko	518-374-2222 72053	CallananCapitalBids@callanan.com	Full 45/45	Zach Hewko	518-374-2222 72053	CallananCapitalBids@callanan.com			American Worksheet.pdf 1127-GC Pre Bid Meeting Agenda Final.pdf	2024/05/28
													1127-GC Addendum 06 drawings.pdf	2024/05/28
													1127-GC Addendum 06 drawings.pdf	2024/05/28
													1127-gc Addendum 05 28 1000 BSD- Access Control.pdf	2024/05/28
													1127-gc Prebid-RFI-007 GC [R] (1).pdf	2024/05/28
													1127-gc addAddendum 05 26 2726 BSD- Wiring Devices.pdf	2024/05/28
													1127-gc Addendum 05 Cover Sheet.pdf	2024/05/28
													1127-gc Prebid-RFI-006 GC [R] (1).pdf	2024/05/28
													1127-gc Prebid-RFI-009R1 GC [R].pdf	2024/05/28
													1127-gc Prebid-RFI-008 GC [R].pdf	2024/05/28
													1127-gc Prebid-RFI-011R1 GC [R].pdf	2024/05/28
													1127-gc Addendum 07 Cover Sheet.pdf	2024/05/28
													1127 GC Addendum 06 cover sheet.pdf	2024/05/28
													1127-GC Addendum #4 2024.05.08 Architectural Drawings Addendum 03.pdf	2024/05/28
													1127-GC Addendum #3 23.0014 - Albany Aiport Terminal A_RGE_Geotech Report.pdf	2024/05/28
													1127-GC Addendum 2- 2024.04.30 Civil Drawings.pdf	2024/05/28
Campito Plumbing & Heating Inc	Po Box 550 3 Hemlock Street	Latham	NY	David Kaufmann	518-785-0994	Kaufmann@campito.com	Partial 1/45	David Kaufmann	518-785-0994	Kaufmann@campito.com	Rehabilitation on Concourse A.pdf	2024/04/30		
Carver Construction	2170 River Rd	Coeymans	NY	Gabe Hanoufa	518-355-6034 157	ghanoufa@carvercompanies.com	Partial 1/45	Gabe Hanoufa	518-355-6034 157	ghanoufa@carvercompanies.com	2024.04.10 100% CD Drawings.pdf	2024/04/25		
Colliers Engineering & Design, Inc.	101 Crawfords Corner Road, Suite 3400	Holmdel	NJ	Donna Kelly	7323831950 3327	donna.kelly@collierseng.com	Partial 1/45	Joanne Munkelt	845-564-4495 3800	jmunkelt@maserconsulting.com	1127 GC Legal Notice.pdf	2024/04/19		
Construction Journal	400 sw 7th street	Stuart	FL	Construction Journal	7727812144	bids@constructionjournal.com	Full 45/45	Construction Journal	7727812144	bids@constructionjournal.com	Rehabilitation on Concourse A.pdf	2024/04/20	1127-GC Pre-bid Attendees.pdf	2024/05/03
											Rehabilitation on Concourse A.pdf	2024/04/24	1127-GC Pre-bid Attendees.pdf	2024/05/03
											2024.04.10 100% CD Drawings.pdf	2024/04/20	1127-GC Pre-bid Attendees.pdf	2024/04/30

2024/04/10 100% CD Drawings.pdf	2024/04/24	1127-gc Addendum 05 Structural Drawings.pdf	2024/05/24
1127 GC Legal Notice.pdf	2024/04/20	1127-GC Addendum 2 2024/04/30 Cw4 Drawings.pdf	2024/05/03
1127 GC Legal Notice.pdf	2024/04/24	1127-GC Addendum 02 Cover Sheet.pdf	2024/05/03
		1127-GC Addendum #3 Prebid-RFI-004 GC R.pdf	2024/05/15
		1127-GC Addendum #3 2024 Architectural Drawing A4.1 Addendum 03.pdf	2024/05/15
		1127-gc Addendum 05 Electrical Drawings.pdf	2024/05/24
		1127-gc Addendum 05 28 1000 BSD- Access Control.pdf	2024/05/24
		1127-GC Addendum 07 Bid Form R2.pdf	2024/05/28
		1127-gc Addendum 05 Cover Sheet.pdf	2024/05/24
		1127-gc addAddendum 05 26 27/28 BSD- Wiring Devices.pdf	2024/05/24
		1127-GC Addendum #3 23.0014 - Albany Airport Terminal A_RGE Geotech Report.pdf	2024/05/15
		1127-GC Addendum 2- PREBID-RFI-001 GC R.pdf	2024/05/03
		1127-gc Addendu 07 Door	2024/05/28
		Handkara.pdf	
		1127-GC Addendum 06 drawings.pdf	2024/05/24
		1127-gc Prebid- RFI-007 GC [R] (1).pdf	2024/05/24
		1127-gc Addendum 07 Prebid-RFI-014 GC [R].pdf	2024/05/28
		1127-gc Addendum 07 Architectural Drawings.pdf	2024/05/28
		1127-GC Addendum #4 2024/04/08 Mechanical Drawings Addendum 03.pdf	2024/05/15
		1127-GC Pre Bid Meeting Agenda Final.pdf	2024/05/03
		1127-GC Pre Bid Meeting Agenda Final.pdf	2024/05/03
		1127-GC Pre Bid Meeting Agenda Final.pdf	2024/05/03

Name	Address	City	State/Prov	Name	Phone	Email		Name	Phone	Email	Document	Download Date	Download Date
Construction Journal	400 sw 7th street	Stuart	FL	Construction Journal	7727812144	bids@constructionjournal.com	Full 45/45	Construction Journal	7727812144	bids@constructionjournal.com	1127-GC Pre Bid Meeting Agenda Final.pdf	2024/04/30	2024/05/28
											1127-gc Addendum 07 Prebid-RFI-013 GC [R].pdf	2024/05/28	2024/05/24
											1127-gc Terminal A Pay Schedule Of Values (Sample).pdf	2024/05/24	2024/05/24
											1127 GC Addendum 06 cover sheet.pdf	2024/05/24	2024/05/24
											1127-gc Prebid-RFI-009R1 GC [R].pdf	2024/05/28	2024/05/28
											1127-gc Addendum 07 Cover Sheet.pdf	2024/05/24	2024/05/24
											1127-gc Prebid-RFI-010 GC [R].pdf	2024/05/24	2024/05/24
											1127-gc Addendum 05 28 2000 BSD-Video Surveillance.pdf	2024/05/28	2024/05/28
											1127gc Addendum 07 Prebid-RFI-012 GC [R].pdf	2024/05/15	2024/05/15
											1127-GC Addendum #4 FAA Form 5100 136 Buy American Worksheet.pdf	2024/05/15	2024/05/15
											1127-GC Addendum #3 Prebid-RFI-003 GC R.pdf	2024/05/15	2024/05/15
											1127-GC Addendum #3 Prebid-RFI-005 GC R.pdf	2024/05/15	2024/05/15
											1127-gc Prebid-RFI-008 GC [R].pdf	2024/05/24	2024/05/28
											1127-gc Addendum 07 Prebid-RFI-015 GC [R].pdf	2024/05/24	2024/05/24
											1127-gc Prebid-RFI-011R1 GC [R].pdf	2024/05/24	2024/05/24
											1127-gc Addendum 05 Civil Drawings.pdf	2024/05/24	2024/05/03
											1127 gc Addendum 06.pdf	2024/05/24	2024/04/30
											1127-GC Addendum #1 cover sheet.pdf	2024/05/03	2024/04/30
											1127-GC Addendum #1 cover sheet.pdf	2024/05/03	2024/05/03
											1127-GC Addendum 2-2024.04.30 Architectural Drawings.pdf	2024/05/15	2024/05/15
											1127-GC Addendum #4 2024.05.08 Architectural Drawings Addendum 03.pdf	2024/05/24	2024/05/24
											1127-gc Prebid-RFI-006 GC [R] (1).pdf	2024/05/24	2024/05/24

													1127-GC Addendum #3 Prebid-RFI-002 GC R.pdf	2024/05/15
													1127-GC Addendum #3 Cover Sheet.pdf	2024/05/15
Convergent Technologies	14 Petra Lane	Albany	NY	Jeremy DeGrasse	518-452-3505	jeremy.degrasse@converginl.com	Partial 3/45	Jeremy DeGrasse	518-452-3505	jeremy.degrasse@converginl.com	2024.04.10 100% CD Drawings.pdf	2024/04/25	1127-GC Addendum #3 Cover Sheet.pdf	2024/05/15
											Rehabilitation on Concourse A.pdf	2024/04/25		
											1127 GC Legal Notice.pdf	2024/04/25		
Cristo Demolition, Inc.	P.O. Box 1636	Albany	NY	Antoinette Cristo	518-463-6985	matt@cristodemolition.com	Partial 13/45	Antoinette Cristo	518-463-6985	matt@cristodemolition.com	Rehabilitation on Concourse A.pdf	2024/05/01	1127-GC Addendum 2-2024.04.30 Civil Drawings.pdf	2024/05/01
											1127 GC Legal Notice.pdf	2024/05/01	1127-GC Addendum #4 FAA Form 5100 136 Buy American Worksheet.pdf	2024/05/10
											2024.04.10 100% CD Drawings.pdf	2024/05/01	1127-GC Addendum 02 Cover Sheet.pdf	2024/05/01
													1127-GC Addendum #4 2024.05.08 Architectural Drawings Addendum 03.pdf	2024/05/10
													1127-GC Pre Bid Meeting Agenda Final.pdf	2024/05/01
													1127-GC Addendum #4 2024.04.08 Mechanical Drawings Addendum 03.pdf	2024/05/10
													1127-GC Addendum 2-2024.04.30 Architectural Drawings.pdf	2024/05/01
													1127-GC Addendum 2-PREBID-RFI-001 GC R.pdf	2024/05/01
													1127-GC Addendum #1 cover sheet.pdf	2024/05/01
													1127-GC Pre-bid Attendees.pdf	2024/05/01
D. A. Collins Construction Co., Inc.	269 Ballard Rd.	Wilton	NY	Ryan Parslow	518-664-9855	DACEstimating@dacollins.com	Full 6/45	Ryan Parslow	518-664-9855	DACEstimating@dacollins.com	1127 GC Legal Notice.pdf	2024/04/19	1127-GC Addendum #1 cover sheet.pdf	2024/04/25
											2024.04.10 100% CD Drawings.pdf	2024/04/19	1127-GC Pre-bid Attendees.pdf	2024/04/25
											Rehabilitation on Concourse A.pdf	2024/04/19	1127-GC Pre Bid Meeting Agenda Final.pdf	2024/04/25
Davco Masonry	2107 fourth Ave	Watervliet	NY	Josh Bressette	518-307-3061	joshb@davcomasonry.com	Partial 3/45	Josh Bressette	518-307-3061	joshb@davcomasonry.com	Rehabilitation on Concourse A.pdf	2024/04/19		
											Rehabilitation on Concourse A.pdf	2024/04/19		
											2024.04.10 100% CD Drawings.pdf	2024/04/19		
											1127 GC Legal Notice.pdf	2024/04/19		
DiGesare Mechanical, Inc.	3434 Carman Road	Schenectady	NY	Lexi Baker	518-356-2224	lexi@digesaregroup.com	Partial 43/45	Lexi Baker	518-356-2224	lexi@digesaregroup.com	1127 GC Legal	2024/04/25	1127-gc Addendum 05 28	2024/05/21

Notice.pdf		2000 BSD-Video Surveillance.pdf	
Rehabilitation on Concourse A.pdf	2024/04/25	1127-GC Addendum #3 23.0014 - Albany Airport Terminal A_RGE_Geotech Report.pdf	2024/05/09
2024.04.10 100% CD Drawings.pdf	2024/04/25	1127-gc Prebid-RFI-009R1 GC [R].pdf	2024/05/21
		1127-GC Addendum #3 Cover Sheet.pdf	2024/05/09
		1127-GC Addendum #3 Cover Sheet.pdf	2024/05/09
		1127-gc Terminal A Pay Schedule Of Values (Sample).pdf	2024/05/21
		1127 GC Addendum 06 cover sheet.pdf	2024/05/22
		1127-gc Addendum 07 Prebid-RFI-014 GC [R].pdf	2024/05/24
		1127-GC Addendum 2- PREBID-RFI-001 GC R.pdf	2024/04/30
		1127-gc Addendum 07 Door Hardware.pdf	2024/05/24
		1127-GC Addendum #3 Prebid-RFI-003 GC R.pdf	2024/05/09
		1127-GC Addendum #3 Prebid-RFI-002 GC R.pdf	2024/05/09
		1127-GC Addendum #3 Prebid-RFI-005 GC R.pdf	2024/05/09
		1127-gc Addendum 05 Electrical Drawings.pdf	2024/05/21
		1127-gc Addendum 05 Civil Drawings.pdf	2024/05/21
		1127-GC Addendum #3 2024. Architectural Drawing A441 Addendum 03.pdf	2024/05/09
		1127-GC Addendum 07 Bid Form R2.pdf	2024/05/24
		1127-gc Addendum 07 Prebid-RFI-013 GC [R].pdf	2024/05/24
		1127-gc Addendum 07 Cover Sheet.pdf	2024/05/24
		1127-gc Addendum 07 Architectural Drawings.pdf	2024/05/24
		1127-gc Addendum 05 Structural Drawings.pdf	2024/05/21
		1127-GC Addendum #4 2024.04.08 Mechanical Drawings	2024/05/09

Name	Address	City	State/Prov	Name	Phone	Email	Document	Name	Phone	Email	Document	Download Date	Download Date
DiGesaro Mechanical, Inc.	3434 Carman Road	Schenectady	NY	Lexi Baker	518-356-2224	lexi@digesaregroup.com	Partial 43/45	Lexi Baker	518-356-2224	lexi@digesaregroup.com	Addendum 03.pdf 1127-gc Prebid-RFI-007 GC [R] (1).pdf 1127-GC Addendum #4 2024.05.08 Architectural Drawings Addendum 03.pdf 1127-gc Prebid-RFI-010 GC [R].pdf 1127-gc Addendum 05 Cover Sheet.pdf 1127-GC Addendum #1 cover sheet.pdf 11270gc Addendum 07 Prebid-RFI-012 GC [R].pdf 1127-GC Addendum 02 Cover Sheet.pdf 1127-gc Addendum 05 28 1000 BSD-Access Control.pdf 1127-gc Prebid-RFI-006 GC [R] (1).pdf 1127 gc Addendum 06.pdf 1127-GC Addendum 2-2024.04.30 Architectural Drawings.pdf 1127-GC Addendum 06 drawings.pdf 1127-GC Addendum 2-2024.04.30 Civil Drawings.pdf 1127-gc Addendum 07 Prebid-RFI-015 GC [R].pdf 1127-gc Prebid-RFI-011R1 GC [R].pdf 1127-GC Addendum #4 FAA Form 5100 136 Buy American Worksheet.pdf 1127-GC Addendum #3 Prebid-RFI-004 GC R.pdf 1127-gc addAddendum 05 26 2728 BSD-Wiring Devices.pdf 1127-gc Prebid-RFI-008 GC [R].pdf	2024/05/21 2024/05/09 2024/05/21 2024/05/21 2024/04/25 2024/05/24 2024/04/30 2024/05/21 2024/05/22 2024/04/30 2024/05/22 2024/04/30 2024/05/24 2024/05/21 2024/05/09 2024/05/09 2024/05/21 2024/05/21	2024/05/21 2024/05/09 2024/05/21 2024/05/21 2024/04/25 2024/05/24 2024/04/30 2024/05/21 2024/05/22 2024/04/30 2024/05/24 2024/05/21 2024/05/09 2024/05/09 2024/05/21 2024/05/21
E Jones Construction Management LLC	44 Blue Barns Road	Roxford	NY	Everett Jones	5183911398	jones.everett11@gmail.com	Partial 1/45	Everett Jones	5183911398	jones.everett11@gmail.com	2024.04.10 100% CD Drawings.pdf	2024/04/24	
EJO Ventures	612 Hangar Ln, Suite 100	Nashville	TN	Steven Snipes	6157553699	steven@ejoventures.net	Partial 10/45	Steven Snipes	6157553699	steven@ejoventures.net	Rehabilitation on Concourse A.pdf 1127-GC Addendum 02 Cover Sheet.pdf	2024/05/08	2024/05/08

Eastern Contractors Association	6 Airline Drive	Albany	NY	Dustin KHenry	(518) 869-0961	dustinh@ecacinc.org	Fuji 4545	Dustin KHenry	(518) 869-0961	dustinh@ecacinc.org	Rehabilitation on Concourse A.pdf	2024/05/16	1127-GC Addendum 2-2024.04.30 Architectural Drawings.pdf	2024/05/08
											1127 GC Legal Notice.pdf	2024/05/08	1127-GC Pre-bid Attendees.pdf	2024/05/08
											2024.04.10 100% CD Drawings.pdf	2024/05/08	1127-GC Addendum 2-2024.04.30 Civil Drawings.pdf	2024/05/08
													1127-GC Addendum 2- PREBID-RFI-001 GC R.pdf	2024/05/08
													1127-GC Pre Bid Meeting Agenda Final.pdf	2024/05/08
													1127-GC Addendum #1 cover sheet.pdf	2024/05/08
											1127 GC Legal Notice.pdf	2024/04/24	1127-gc Addendum 05 28 1000 BSD-Accas Control.pdf	2024/05/21
													1127-gc Addendum 07 Prebid-RFI-013 GC [R].pdf	2024/05/25
													1127-GC Pre Bid Meeting Agenda Final.pdf	2024/04/25
													1127-gc Terminal A Pay Schedule OI Values (Sample).pdf	2024/05/21
													1127-gc Prebid-RFI-008 GC [R].pdf	2024/05/21
													1127 GC Addendum 06 cover sheet.pdf	2024/05/22
													1127-gc Prebid-RFI-007 GC [R] (1).pdf	2024/05/21
													1127-GC Addendum #3 Prebid-RFI-005 GC R.pdf	2024/05/09
													1127-gc Addendum 05 Electrical Drawings.pdf	2024/05/21
													1127-GC Pre-bid Attendees.pdf	2024/04/25
													1127-gc Addendum 07 Prebid-RFI-014 GC [R].pdf	2024/05/25
													1127-GC Addendum 2- PREBID-RFI-001 GC R.pdf	2024/04/30
													1127-GC Addendum #4 2024.04.08 Mechanical Drawings Addendum 03.pdf	2024/05/09
													1127-GC Addendum #3 Prebid-RFI-003 GC R.pdf	2024/05/09
													1127-GC Addendum 2-2024.04.30 Architectural Drawings.pdf	2024/04/30
													1127gc Addendum 07 Prebid-RFI-012 GC [R].pdf	2024/05/25

Name	Address	City	State/Prov	Name	Phone	Email
Eastern Contractors Association	6 Airline Drive	Albany	NY	Dustin KHenry	(518) 869-0961	dustinh@eca-inc.org

Full 45/45

Name	Phone	Email
Dustin KHenry	(518) 869-0961	dustinh@eca-inc.org

Document	Download Date
1127-gc Addendum 05 28 2000 BSD-Video Surveillance.pdf	2024/05/21
1127-gc Addendum 07 Door Hardware.pdf	2024/05/25
1127-GC Addendum #1 cover sheet.pdf	2024/04/25
1127-GC Addendum #3 Prebid-RFI-004 GC R.pdf	2024/05/09
1127-GC Addendum #4 FAA Form 5100 136 Buy American Worksheet.pdf	2024/05/09
1127-gc Prebid-RFI-010 GC [R].pdf	2024/05/21
1127-GC Addendum 06 drawings.pdf	2024/05/22
1127-GC Addendum #3 Cover Sheet.pdf	2024/05/09
1127-GC Addendum #3 2024 Architectural Drawing A441 Addendum 03.pdf	2024/05/09
1127-gc Prebid-RFI-011R1 GC [R].pdf	2024/05/21
1127 gc Addendum 06.pdf	2024/05/22
1127-gc addAddendum 05 26 2726 BSD-Wing Devices.pdf	2024/05/21
1127-gc Addendum 07 Architectural Drawings.pdf	2024/05/25
1127-gc Addendum 05 Civil Drawings.pdf	2024/05/21
1127-gc Addendum 07 Prebid-RFI-015 GC [R].pdf	2024/05/25
1127-GC Addendum #3 23.0014 - Albany Airport Terminal A_RGE_Geotech Report.pdf	2024/05/09
1127-gc Prebid-RFI-009R1 GC [R].pdf	2024/05/21
1127-gc Prebid-RFI-006 GC [R] (1).pdf	2024/05/21
1127-GC Addendum 2-2024.04.30 Civil Drawings.pdf	2024/04/30
1127-GC Addendum 02 Cover Sheet.pdf	2024/04/30
1127-gc Addendum 07 Cover Sheet.pdf	2024/05/25

													1127-gc Addendum 05 Cover Sheet.pdf	2024/05/21
													1127-GC Addendum 07 Bid Form R2.pdf	2024/05/25
													1127-GC Addendum #3 Prebid-RFI-002 GC R.pdf	2024/05/09
													1127-gc Addendum 05 Structural Drawings.pdf	2024/05/21
													1127-GC Addendum #4 2024.05.08 Architectural Drawings Addendum 03.pdf	2024/05/09
Eaton Crouse- Hinds Airport Lighting Products	1200 Kennedy Road	Windsor	CT	James Teixeira	631-901- 4825	jimdteixeira@eaton.com	Partial 1/45	James Teixeira	631-901- 4825	jimdteixeira@eaton.com	1127 GC Legal Notice.pdf	2024/05/21		
Eckert Mechanical, LLC.	1062 Central Ave	Albany	NY	Russell Lincoln	518-459- 4116 244	rlincoln@eckertmechanical.com	Full 45/45	Russell Lincoln	518-459- 4116 244	rlincoln@eckertmechanical.com	1127 GC Legal Notice.pdf	2024/04/18	1127-GC Addendum #3 Prebid-RFI-005 GC R.pdf	2024/05/09
											Rehabilitation on Concourse A.pdf	2024/04/18	1127-gc Prebid- RFI-008 GC [R].pdf	2024/05/21
											Rehabilitation on Concourse A.pdf	2024/04/18	1127-gc Addendum 05 Civil Drawings.pdf	2024/05/21
											2024.04.10 100% CD Drawings.pdf	2024/04/18	1127-gc Addendum 07 Cover Sheet.pdf	2024/05/28
											2024.04.10 100% CD Drawings.pdf	2024/04/18	1127-gc Addendum 07 Prebid-RFI-014 GC [R].pdf	2024/05/28
													1127 GC Addendum 06 cover sheet.pdf	2024/05/24
													1127-GC Addendum #4 2024.05.08 Architectural Drawings Addendum 03.pdf	2024/05/09
													1127 gc Addendum 06.pdf	2024/05/24
													1127-GC Addendum 2- 2024.04.30 Architectural Drawings.pdf	2024/05/01
													1127-gc Addendum 05 Electrical Drawings.pdf	2024/05/21
													1127-GC Addendum #4 2024.04.08 Mechanical Drawings Addendum 03.pdf	2024/05/09
													1127-GC Addendum 2- 2024.04.30 Civil Drawings.pdf	2024/05/01
													1127-gc Prebid- RFI-010 GC [R].pdf	2024/05/21
													1127-GC Addendum #3 Prebid-RFI-002 GC R.pdf	2024/05/09
													1127-gc Prebid- RFI-007 GC [R] (1).pdf	2024/05/21

1127-GC Addendum #4 FAA Form 5100 136 Buy American Worksheet.pdf	2024/05/09
1127-GC Addendum #3 Prebid-RFI-003 GC R.pdf	2024/05/09
1127-gc Addendum 05 Structural Drawings.pdf	2024/05/21
1127-gc Prebid- RFI-006 GC [R] (1).pdf	2024/05/21
1127-gc Addendum 07 Prebid-RFI-013 GC [R].pdf	2024/05/28
1127-gc Addendum 05 28 1000 BSD- Access Control.pdf	2024/05/21
1127-GC Pre Bid Meeting Agenda Final.pdf	2024/04/26
1127-GC Addendum 07 Bid Form R2.pdf	2024/05/28
1127-gc Addendum 07 Door Hardware.pdf	2024/05/28
1127-gc Prebid- RFI-009R1 GC [R].pdf	2024/05/21
1127-GC Addendum #3 Prebid-RFI-004 GC R.pdf	2024/05/09
1127-GC Addendum 06 drawings.pdf	2024/05/24
1127-GC Addendum #1 cover sheet.pdf	2024/04/26
1127-gc Prebid- RFI-011R1 GC [R].pdf	2024/05/21
1127-GC Addendum #3 2024. Architectural Drawing A441 Addendum 03.pdf	2024/05/09
1127-gc Addendum 05 Cover Sheet.pdf	2024/05/21
1127-GC Addendum 02 Cover Sheet.pdf	2024/05/01
1127-GC Pre-bid Attendees.pdf	2024/04/26
1127-gc addAddendum 05 26 2726 BSD- Writing Devices.pdf	2024/05/21
1127-gc Terminal A Pay Schedule Of Values (Sample).pdf	2024/05/21
1127-gc Addendum 05 28 2000 BSD-Vieso Surveillance.pdf	2024/05/21
1127Gc Addendum 07 Prebid-RFI-012 GC [R].pdf	2024/05/28
1127-gc Addendum 07	2024/05/28

Name	Address	City	State/Prov	Name	Phone	Email		Name	Phone	Email	Document	Download Date	Document	Download Date
Eckert Mechanical, LLC.	1062 Central Ave	Albany	NY	Russell Lincoln	518-459-4116 244	rlincoln@eckertmechanical.com	Full 45/45	Russell Lincoln	518-459-4116 244	rlincoln@eckertmechanical.com			Prebid-RFI-015 GC [R].pdf	
FENNICK MCCREDIE ARCHITECTURE	70 FRANKLIN STREET, 2ND FLOOR	BOSTON	MA	Melissa Vaillancourt	6173507900	mvaillancourt@fmarchitecture.com	Partial 36/45	Melissa Vaillancourt	6173507900	mvaillancourt@fmarchitecture.com	2024.04.10 100% CD Drawings.pdf	2024/04/25	1127-gc Prebid-RFI-008 GC [R].pdf	2024/05/21
											1127 GC Legal Notice.pdf	2024/04/25	1127-gc Prebid-RFI-008 GC [R].pdf	2024/05/21
											Rehabilitation on Concourse A.pdf	2024/04/25	1127-GC Addendum #3 Prebid-RFI-004 GC R.pdf	2024/05/13
													1127-GC Addendum #4 FAA Form 5100 136 Buy American Worksheet.pdf	2024/05/13
													1127-gc Addendum 05 Cover Sheet.pdf	2024/05/21
													1127-gc Addendum 05 Cover Sheet.pdf	2024/05/21
													1127-gc Addendum 05 Cover Sheet.pdf	2024/05/21
													1127-GC Addendum #3 Prebid-RFI-003 GC R.pdf	2024/05/13
													1127-GC Addendum #3 23.0014 - Albany Airport Terminal A_RGE_Geotech Report.pdf	2024/05/13
													1127-gc Prebid-RFI-007 GC [R] (1).pdf	2024/05/21
													1127-gc Prebid-RFI-007 GC [R] (1).pdf	2024/05/21
													1127-gc Addendum 05 Electrical Drawings.pdf	2024/05/21
													1127-gc Addendum 05 Electrical Drawings.pdf	2024/05/21
													1127-gc Prebid-RFI-010 GC [R].pdf	2024/05/21
													1127-gc Prebid-RFI-010 GC [R].pdf	2024/05/21
													1127-gc Prebid-RFI-006 GC [R] (1).pdf	2024/05/21
													1127-gc Prebid-RFI-006 GC [R] (1).pdf	2024/05/21
													1127-GC Addendum #3 Cover Sheet.pdf	2024/05/13

1127-GC Pre Bid Meeting Agenda Final.pdf	2024/04/25
1127-GC Addendum #3 2024. Architectural Drawing A441 Addendum 03.pdf	2024/05/13
1127-GC Addendum #3 Prebid-RFI-002 GC R.pdf	2024/05/13
1127-GC Addendum #3 Prebid-RFI-005 GC R.pdf	2024/05/13
1127-gc addAddendum 05 26 2726 BSD-Wiring Devices.pdf	2024/05/21
1127-gc addAddendum 05 26 2726 BSD-Wiring Devices.pdf	2024/05/21
1127-GC Addendum #1 cover sheet.pdf	2024/04/25
1127-gc Addendum 05 Civil Drawings.pdf	2024/05/21
1127-gc Addendum 05 Civil Drawings.pdf	2024/05/21
1127-GC Addendum #4 2024.04.08 Mechanical Drawings Addendum 03.pdf	2024/05/13
1127-GC Addendum 2- PREBID-RFI-001 GC R.pdf	2024/05/13
1127-gc Prebid-RFI-009R1 GC [R].pdf	2024/05/21
1127-gc Prebid-RFI-009R1 GC [R].pdf	2024/05/21
1127-gc Terminal A Pay Schedule Of Values (Sample).pdf	2024/05/21
1127-gc Terminal A Pay Schedule Of Values (Sample).pdf	2024/05/21
1127 gc Addendum 06.pdf	2024/05/23
1127-GC Pre-bid Attendees.pdf	2024/04/25
1127-GC Pre-bid Attendees.pdf	2024/04/25
1127-GC Addendum 02 Cover Sheet.pdf	2024/05/13
1127-gc Addendum 05 28 1000 BSD-Access Control.pdf	2024/05/21
1127-gc Addendum 05 28 1000 BSD-Access Control.pdf	2024/05/21
1127-gc Addendum 05 28	2024/05/21

Name	Address	City	State/Prov	Name	Phone	Email		Name	Phone	Email	Document	Download Date	Document	Download Date
Foit Albert Associates	435 New Karner Road	Albany	NY	Peggy Gust-Anger	518-452-1037	cstoebe@foit-albert.com	Partial 2/45	Peggy Gust-Anger	518-452-1037	cstoebe@foit-albert.com	2024.04.10 100% CD Drawings.pdf	2024/04/19		
Foit Albert Associates	435 New Karner Road	Albany	NY	Peggy Gust-Anger	518-452-1037	cstoebe@foit-albert.com	Partial 2/45	Peggy Gust-Anger	518-452-1037	cstoebe@foit-albert.com	Rehabilitation on Concourse A.pdf	2024/04/19	Rehabilitation on Concourse A.pdf	2024/04/19
Greenwood Industries, Inc.	4 Locust Street	Hudson Falls	NY	Joshua Ruehle	9172803943	jruehle@greenwood-industries.com	Partial 4/45	Joshua Ruehle	9172803943	jruehle@greenwood-industries.com	Rehabilitation on Concourse A.pdf	2024/05/06	1127-GC Addendum #4 2024.05.08 Architectural Drawings Addendum 03.pdf	2024/05/09
Greenwood Industries, Inc.	4 Locust Street	Hudson Falls	NY	Joshua Ruehle	9172803943	jruehle@greenwood-industries.com	Partial 4/45	Joshua Ruehle	9172803943	jruehle@greenwood-industries.com	Rehabilitation on Concourse A.pdf	2024/05/06	1127-GC Addendum #3 Cover Sheet.pdf	2024/05/09
Group PMX	25 Leroy Pl, PH12	New Rochelle	NY	Jenny Freeman	6462611399	jfreeman@grouppmx.com	Partial 1/45	Jenny Freeman	6462611399	jfreeman@grouppmx.com	Rehabilitation on Concourse A.pdf	2024/04/19	1127-GC Addendum #3 2024. Architectural Drawing A441 Addendum 03.pdf	2024/05/09
Harold R Clune	30 Prospect St	Ballston Spa	NY	Brian WClune	5188856199	brian@cluneelectric.com	Full 7/45	Brian WClune	5188856199	brian@cluneelectric.com	Rehabilitation on Concourse A.pdf	2024/04/18	1127-GC Pre-bid Attendees.pdf	2024/04/25
Harold R Clune	30 Prospect St	Ballston Spa	NY	Brian WClune	5188856199	brian@cluneelectric.com	Full 7/45	Brian WClune	5188856199	brian@cluneelectric.com	Rehabilitation on Concourse A.pdf	2024/04/19	1127-gc Addendum 05 Cover Sheet.pdf	2024/05/21
Harold R Clune	30 Prospect St	Ballston Spa	NY	Brian WClune	5188856199	brian@cluneelectric.com	Full 7/45	Brian WClune	5188856199	brian@cluneelectric.com	1127 GC Legal Notice.pdf	2024/04/18	1127-GC Addendum #1 cover sheet.pdf	2024/04/25
													2000 BSD-Video Surveillance.pdf	2024/05/21
													1127-gc Addendum 05 28 2000 BSD-Video Surveillance.pdf	2024/05/13
													1127-GC Addendum 2-2024.04.30 Civil Drawings.pdf	2024/05/21
													1127-gc Addendum 05 Structural Drawings.pdf	2024/05/21
													1127-gc Addendum 05 Structural Drawings.pdf	2024/05/23
													1127-GC Addendum 06 drawings.pdf	2024/05/13
													1127-GC Addendum 2-2024.04.30 Architectural Drawings.pdf	2024/05/13
													1127-GC Addendum #4 2024.05.08 Architectural Drawings Addendum 03.pdf	2024/05/21
													1127-gc Prebid-RFI-011R1 GC [R].pdf	2024/05/21
													1127-gc Prebid-RFI-011R1 GC [R].pdf	2024/05/21

											1127 GC Legal Notice.pdf	2024/04/19	1127-GC Pre Bid Meeting Agenda Final.pdf	2024/04/25
											1127 GC Legal Notice.pdf	2024/04/19		
											2024.04.10 100% CD Drawings.pdf	2024/04/18		
											2024.04.10 100% CD Drawings.pdf	2024/04/18		
											2024.04.10 100% CD Drawings.pdf	2024/04/19		
Heuer & Company	3 Bohnert Place	Waldwick	NJ	Kathleen Zawryt	2014930220	kzawryt@heuerandcompany.com	Partial 2/45	Kathleen Zawryt	2014930220	kzawryt@heuerandcompany.com	Rehabilitation on Concourse A.pdf	2024/04/18		
											1127 GC Legal Notice.pdf	2024/04/18		
Hudson Meridian Construction Group	61 Broadway, 7th Floor	New York	NY	Juliano Febo	518-944-5449	jfebo@hudsonmeridian.com	Partial 10/45	Juliano Febo	518-944-5449	jfebo@hudsonmeridian.com	1127 GC Legal Notice.pdf	2024/04/18	1127-GC Pre Bid Meeting Agenda Final.pdf	2024/04/25
											2024.04.10 100% CD Drawings.pdf	2024/04/18	1127-GC Addendum 2-2024.04.30 Architectural Drawings.pdf	2024/04/30
											Rehabilitation on Concourse A.pdf	2024/04/18	1127 GC Addendum 06 cover sheet.pdf	2024/05/22
													1127 gc Addendum 06.pdf	2024/05/22
													1127-GC Addendum 02 Cover Sheet.pdf	2024/04/30
													1127-GC Addendum #1 cover sheet.pdf	2024/04/25
J.N. Giammarino Construction Inc.	671 Conklin Road	Binghamton	NY	Elizabeth JOakley-Craven	607-724-0840	liz@jngiammarino.com	Full 9/45	Elizabeth JOakley-Craven	607-724-0840	liz@jngiammarino.com	2024.04.10 100% CD Drawings.pdf	2024/05/24	1127-GC Pre-bid Attendees.pdf	2024/04/25
													1127-GC Addendum #3 23.0014 - Albany Airport Terminal A_RGE_Geotech Report.pdf	2024/05/24
													1127 gc Addendum 06.pdf	2024/05/24
													1127-gc Addendum 05 Structural Drawings.pdf	2024/05/24
													1127-GC Addendum 2-2024.04.30 Civil Drawings.pdf	2024/05/24
													1127-gc Addendum 07 Architectural Drawings.pdf	2024/05/24
													1127-gc Addendum 07 Prebid-RFI-013 GC [R].pdf	2024/05/24
													1127-GC Addendum 06 drawings.pdf	2024/05/24
													1127Gc Addendum 07 Prebid-RFI-012 GC [R].pdf	2024/05/24
JLL	200 East Randolph	Chicago	IL	Chrs Jardis	7042809582	chris.jardis@jll.com	Partial 3/45	Chris Jardis	7042809582	chris.jardis@jll.com	2024.04.10 100% CD Drawings.pdf	2024/04/18		
											1127 GC Legal Notice.pdf	2024/04/18		
											Rehabilitation on	2024/04/18		

Name	Address	City	State/Prov	Name	Phone	Email	Name	Phone	Email	Document	Download Date
KIM Industries	1 Fairchild Drive	Clifton Park	NY	Ray Levesque	5182070726	revesque@kimindustries.com	Ray Levesque	5182070726	revesque@kimindustries.com	Concourse A.pdf 2024-04-10 100% CD Drawings.pdf	2024/04/18
										1127-gc Addendum 05 28 1000 BSD-Access Control.pdf	2024/05/21
										1127 gc Addendum 06.pdf	2024/05/22
										1127-gc Addendum 07 Prebid-RF1-014 GC [R].pdf	2024/05/24
										1127-GC Addendum #4 FAA Form 5100 136 Buy American Worksheet.pdf	2024/05/09
										1127gc Addendum 07 Prebid-RF1-012 GC [R].pdf	2024/05/24
										1127-GC Pre-bid Attendees.pdf	2024/04/25
										1127-GC Pre-bid Attendees.pdf	2024/04/25
										1127-GC Addendum #1 cover sheet.pdf	2024/04/25
										1127-GC Addendum #1 cover sheet.pdf	2024/04/25
										1127-gc Addendum 07 Prebid-RF1-013 GC [R].pdf	2024/05/24
										1127-gc Addendum 05 Civil	2024/05/21
										Drawings.pdf	2024/05/24
										1127-gc Addendum 07 Architectural Drawings.pdf	2024/05/21
										1127-gc Prebid-RF-010 GC [R].pdf	2024/05/21
										1127-GC Addendum #3 Prebid-RF1-002 GC R.pdf	2024/05/09
										1127-GC Pre Bid Meeting Agenda Final.pdf	2024/04/25
										1127-gc Prebid-RF1-008 GC [R].pdf	2024/05/21
										1127-gc Prebid-RF-008 GC [R].pdf	2024/05/21
										1127-gc Prebid-RF-009R1 GC [R].pdf	2024/05/21
										1127-GC Addendum #3 2024. Architectural Drawing A441 Addendum 03.pdf	2024/05/09
										1127-GC Addendum #4 2024.04.08 Mechanical Drawings Addendum 03.pdf	2024/05/09
KIM Industries	1 Fairchild Drive	Clifton Park	NY	Ray Levesque	5182070726	revesque@kimindustries.com	Ray Levesque	5182070726	revesque@kimindustries.com	Document 1127-GC Addendum 2- PREBID-RF1-001 GC R.pdf	2024/04/30

1127-GC Addendum #3 Prebid-RFI-003 GC R.pdf	2024/05/09
1127-GC Addendum #3 Prebid-RFI-005 GC R.pdf	2024/05/09
1127-gc Addendum 07 Prebid-RFI-015 GC [R].pdf	2024/05/24
1127-GC Addendum 2- 2024.04.30 Architectural Drawings.pdf	2024/04/30
1127-GC Addendum 2- 2024.04.30 Architectural Drawings.pdf	2024/04/30
1127-GC Addendum #3 Prebid-RFI-004 GC R.pdf	2024/05/09
1127-GC Addendum 07 Bid Form R2.pdf	2024/05/24
1127-GC Addendum #3 23.0014 - Albany Airport Terminal A_RGE_Geotech Report.pdf	2024/05/09
1127-gc Prebid- RFI-011R1 GC [R].pdf	2024/05/21
1127-gc Addendum 07 Door Hardware.pdf	2024/05/24
1127-gc Terminal A Pay Schedule Of Values (Sample).pdf	2024/05/21
1127-gc Addendum 05 Structural Drawings.pdf	2024/05/21
1127-gc Addendum 05 28 2000 BSD-Video Surveillance.pdf	2024/05/21
1127-gc Addendum 07 Cover Sheet.pdf	2024/05/24
1127-gc Addendum 05 Electrical Drawings.pdf	2024/05/21
1127-GC Addendum 06 drawings.pdf	2024/05/22
1127-GC Addendum #3 Cover Sheet.pdf	2024/05/09
1127-gc Prebid- RFI-006 GC [R] (1).pdf	2024/05/21
1127 GC Addendum 06 cover sheet.pdf	2024/05/22
1127-GC Addendum 2- 2024.04.30 Cvr1 Drawings.pdf	2024/04/30
1127-gc Prebid- RFI-007 GC [R] (1).pdf	2024/05/21
1127-gc Addendum 05-26 2726 BSD- Wiring Devices.pdf	2024/05/21
1127-GC Addendum 02	2024/04/30

Kencal Maintenance Corporation	399 Knollwood Road	White Plains	NY	Keri Dreyer	914-761-5900	kdreyer@kencalmaintenance.com	Full 5/45	Keri Dreyer	914-761-5900	kdreyer@kencalmaintenance.com	Rehabilitation on Concourse A.pdf	2024/04/30	Cover Sheet.pdf	2024/05/09
													1127-GC Addendum #4 2024.05.08 Architectural Drawings Addendum 03.pdf	
													1127-gc Addendum 05 Cover Sheet.pdf	2024/05/21
													1127-gc Addendum 05 Cover Sheet.pdf	2024/05/21
Keeberg Sheet Metal, Inc	65 Westover Road	Ludlow	MA	David Kiely	518-522-2157	dkely@keeberg.com	Partial 10/45	David Kiely	518-522-2157	dkely@keeberg.com		2024/04/30	1127-GC Pro-bid Attendees.pdf	2024/04/30
													1127-GC Addendum #1 cover sheet.pdf	2024/04/30
													1127-GC Pre Bid Meeting Agenda Final.pdf	2024/04/30
													1127-GC Addendum 2- PREBID-RFI-001 GC R.pdf	2024/05/20
Kokolakis Contracting	202 East Center Street	Tarpon Springs	FL	Andria Sartor	7279422211	marketing@jokolakis.com	Partial 20/45	Andria Sartor	7279422211	marketing@jokolakis.com	Rehabilitation on Concourse A.pdf	2024/04/25	1127-GC Addendum #3 Prebid-RFI-002 GC R.pdf	2024/05/20
													1127-GC Addendum #3 2024. Architectural Drawing A441 Addendum 03.pdf	2024/05/20
													1127-GC Addendum #3 23.0014 - Albany Airport Terminal A_RGE_Geotech Report.pdf	2024/05/20
													1127-GC Addendum #3 Cover Sheet.pdf	2024/05/20
Kokolakis Contracting	202 East Center Street	Tarpon Springs	FL	Andria Sartor	7279422211	marketing@jokolakis.com	Partial 20/45	Andria Sartor	7279422211	marketing@jokolakis.com	1127 GC Legal Notice.pdf	2024/04/25	1127-GC Addendum #3 Prebid-RFI-004 GC R.pdf	2024/05/20
													1127-GC Addendum #3 Prebid-RFI-003 GC R.pdf	2024/05/20
													1127-GC Addendum #3 Prebid-RFI-005 GC R.pdf	2024/05/20
													1127-GC Addendum #4 2024.05.08 Architectural Drawings Addendum 03.pdf	2024/05/20
Kokolakis Contracting	202 East Center Street	Tarpon Springs	FL	Andria Sartor	7279422211	marketing@jokolakis.com	Partial 20/45	Andria Sartor	7279422211	marketing@jokolakis.com	1127 GC Legal Notice.pdf	2024/04/25	1127-GC Addendum #3 Prebid-RFI-004 GC R.pdf	2024/05/20
													1127-GC Addendum #3 Prebid-RFI-003 GC R.pdf	2024/05/20
													1127-GC Addendum #3 Prebid-RFI-005 GC R.pdf	2024/05/20
													1127-GC Addendum #4 2024.04.08 Mechanical Drawings Addendum 03.pdf	2024/05/20
Kokolakis Contracting	202 East Center Street	Tarpon Springs	FL	Andria Sartor	7279422211	marketing@jokolakis.com	Partial 20/45	Andria Sartor	7279422211	marketing@jokolakis.com	1127 GC Legal Notice.pdf	2024/04/25	1127-GC Addendum #4 FAA Form 5100 136 Buy American Worksheet.pdf	2024/04/30
													1127-GC Addendum #4 2024.04.30 Civil Drawings.pdf	2024/05/09
													1127-GC Addendum #4 2024.05.08 Architectural Drawings Addendum 03.pdf	2024/05/09
													1127-GC Addendum #4 2024.05.08 Architectural Drawings Addendum 03.pdf	2024/05/09

Name	Address	City	State/Prov	Name	Phone	Email	Name	Phone	Email	Document	Download Date	
Kubicky Kokolakis Contracting	269 Ballard Road	Wilton	NY	Volker Burkowski	5187925564	vburkowsk@dacollins.com	Partial 2045	Volker Andria Santor	7279422211	marketing@kokolakis.com	1127-GC Legal Notice.pdf	2024/04/25
											Drawings Addendum 03.pdf	2024/05/09
											1127-GC Addendum #3	2024/04/30
											Architectural Drawing A441 Addendum 03.pdf	2024/05/09
											1127-GC Addendum #3 Prebid-RFI-002 GC R.pdf	2024/04/30
											1127-GC Addendum #1 cover sheet.pdf	2024/04/30
											1127-GC Addendum #1 cover sheet.pdf	2024/05/09
											1127-GC Addendum #3 23.0014 - Albany Airport Terminal A_IRGE_Geotech Report.pdf	2024/05/09
											1127-GC Addendum #3 Prebid-RFI-005 GC R.pdf	2024/05/09
											1127-GC Addendum #4 2024.04.08 Mechanical Drawings Addendum 03.pdf	2024/05/09
											1127-GC Addendum 2- PREBID-RFI-001 GC R.pdf	2024/04/30
											1127-GC Addendum 2- PREBID-RFI-001 GC R.pdf	2024/04/30
											1127-GC Addendum #3 Prebid-RFI-004 GC R.pdf	2024/05/09
											1127-GC Addendum 02	2024/04/30
											1127-GC Cover Sheet.pdf	2024/05/09
											1127-GC Addendum #4 FAA Form 5100 138 Buy American Worksheet.pdf	2024/05/09
											1127-GC Addendum #3 Cover Sheet.pdf	2024/05/09
											1127-GC Addendum #3 Cover Sheet.pdf	2024/05/09
											1127-GC Pre-bid Attendees.pdf	2024/04/30
1127-GC Pre Bid Meeting Agenda Final.pdf	2024/04/30											
1127-GC Addendum #3 Prebid-RFI-003 GC R.pdf	2024/05/09											
1127-GC Addendum 2- 2024.04.30 Architectural Drawings.pdf	2024/04/30											
Kubicky Construction Corp.	269 Ballard Road	Wilton	NY	Volker Burkowski	5187925564	vburkowsk@dacollins.com	Partial 2045	Volker Andria Santor	7279422211	marketing@kokolakis.com	Rehabilitation on	2024/04/19

											Concourse A.pdf	2024/04/19		
											Rehabilitation on Concourse A.pdf	2024/04/19		
											2024.04.10 100% CD Drawings.pdf	2024/04/19		
											2024.04.10 100% CD Drawings.pdf	2024/04/19		
LAW Lighting Inc	443 Fifth Avenue	Pelham	NY	Lisa AWasicsko	914-740-3065	lisa@lawlighting.com	Partial 13/45	Lisa AWasicsko	914-740-3065	lisa@lawlighting.com			1127-gc Prebid-RFI-011R1 GC [R].pdf	2024/05/22
													1127-gc Prebid-RFI-010 GC [R].pdf	2024/05/22
													1127-gc Addendum 05 Electrical Drawings.pdf	2024/05/22
													1127-gc Prebid-RFI-008 GC [R].pdf	2024/05/22
													1127-gc Addendum 05 Civil Drawings.pdf	2024/05/22
													1127-gc addAddendum 05 26 2726 BSD-Wiring Devices.pdf	2024/05/22
													1127-gc addAddendum 05 26 2726 BSD-Wiring Devices.pdf	2024/05/22
													1127-gc Prebid-RFI-006 GC [R] (1).pdf	2024/05/22
													1127-gc Addendum 05 Structural Drawings.pdf	2024/05/22
													1127-gc Addendum 05 28 1000 BSD-Access Control.pdf	2024/05/22
													1127-gc Prebid-RFI-007 GC [R] (1).pdf	2024/05/22
													1127-gc Addendum 05 28 2000 BSD-Video Surveillance.pdf	2024/05/22
													1127-gc Addendum 05 Cover Sheet.pdf	2024/05/22
													1127-gc Prebid-RFI-009R1 GC [R].pdf	2024/05/22
LeChase Construction	205 Indigo Creek	Rochester	NY	Patrick Griffin	5854024984	Patrick.Griffin@lechase.com	Partial 4/45	Patrick Griffin	5854024984	Patrick.Griffin@lechase.com	Rehabilitation on Concourse A.pdf	2024/04/24	1127-GC Addendum #1 cover sheet.pdf	2024/04/25
											1127 GC Legal Notice.pdf	2024/04/24		
											2024.04.10 100% CD Drawings.pdf	2024/04/24		
M & J Engineering P.C.	110 Bi-County Boulevard	S Farmingdale NY	NY	Isabella Torelli	5169418494	itorelli@mjengineers.com	Partial 2/45	Isabella Torelli	5169418494	itorelli@mjengineers.com	Rehabilitation on Concourse A.pdf	2024/04/19		
											2024.04.10 100% CD Drawings.pdf	2024/04/19		
MLB Construction Services, LLC	1 Stone Break Road	Ballston Spa	NY	Shauna Raymond	(518)289-1371	sraymond@mlbind.com	Partial 20/45	Shauna Raymond	(518)289-1371	sraymond@mlbind.com	2024.04.10 100% CD Drawings.pdf	2024/04/24	1127-GC Addendum #4 FAA Form 5100 136 Buy	2024/05/09

												American Worksheet.pdf		
											1127 GC Legal Notice.pdf	2024/04/24	1127-GC Addendum #1 cover sheet.pdf	2024/04/30
											Rehabilitation on Concourse A.pdf	2024/04/24	1127-GC Addendum 2-2024.04.30 Architectural Drawings.pdf	2024/04/30
													1127-GC Addendum 02 Cover Sheet.pdf	2024/04/30
													1127-GC Addendum #4 2024.04.08 Mechanical Drawings Addendum 03.pdf	2024/05/09
													1127-GC Addendum #3 Prebid-RFI-004 GC R.pdf	2024/05/09
													1127-GC Pre Bid Meeting Agenda Final.pdf	2024/04/30
													1127-GC Addendum #3 Prebid-RFI-002 GC R.pdf	2024/05/09
													1127-GC Addendum #3 Prebid-RFI-002 GC R.pdf	2024/05/09
													1127-GC Addendum #3 Prebid-RFI-003 GC R.pdf	2024/05/09
													1127-GC Addendum #3 23.0014 - Albany Airport Terminal A_RGE_Geotech Report.pdf	2024/05/09
													1127-GC Addendum #3 Prebid-RFI-005 GC R.pdf	2024/05/09
													1127-GC Addendum #3 Cover Sheet.pdf	2024/05/09
													1127-GC Addendum 2- PREBID-RFI-001 GC R.pdf	2024/04/30
													1127-GC Addendum #3 2024. Architectural Drawing A441 Addendum 03.pdf	2024/05/09
													1127-GC Pre-bid Attendees.pdf	2024/04/30
													1127-GC Addendum 2-2024.04.30 Civil Drawings.pdf	2024/04/30
													1127-GC Addendum #4 2024.05.08 Architectural Drawings Addendum 03.pdf	2024/05/09
Merit Apprenticeship Alliance	6320 Fly Rd., Suite 210A	East Syracuse	NY	Penelope Hazer	13154408989	pmhazer@MeritAlliance.org	Partial 1/45	Penelope Hazer	13154408989	pmhazer@MeritAlliance.org	Rehabilitation on Concourse A.pdf	2024/04/19		
Mumane Building Contractors	287 Ushers Road	Clifton Park	NY	Michael Mumane	5189783300	mmumane@mumanebuilding.com	Full 45/45	Michael Mumane	5189783300	mmumane@mumanebuilding.com	Rehabilitation on Concourse A.pdf	2024/04/19		
											Rehabilitation on	2024/04/24	1127-gc Addendum 05	2024/05/22

Name	Address	City	State/Prov	Name	Phone	Email		Name	Phone	Email
Mumane Building Contractors	287 Ushers Road	Clifton Park	NY	Michael Mumane	5189783300	mmumane@mumanebuilding.com	Full 45/45	Michael Mumane	5189783300	mmumane@mumanebuilding.com

Document	Download Date	Document	Download Date
Concourse A.pdf		Electrical Drawings.pdf	
Rehabilitation on Concourse A.pdf	2024/04/24	1127-gc Addendum 07 Prebid-RFI-014 GC [R].pdf	2024/05/24
Rehabilitation on Concourse A.pdf	2024/04/30	1127-GC Pre Bid Meeting Agenda Final.pdf	2024/04/30
Rehabilitation on Concourse A.pdf	2024/05/01	1127-GC Pre Bid Meeting Agenda Final.pdf	2024/05/22
2024.04.10 100% CD Drawings.pdf	2024/04/24	1127-gc Prebid-RFI-011R1 GC [R].pdf	2024/05/22
2024.04.10 100% CD Drawings.pdf	2024/04/24	1127-gc Prebid-RFI-009R1 GC [R].pdf	2024/05/22
2024.04.10 100% CD Drawings.pdf	2024/04/30	1127-GC Addendum #3 Prebid-RFI-002 GC R.pdf	2024/05/22
1127 GC Legal Notice.pdf	2024/04/24	1127-GC Addendum 2-2024.04.30 Civil Drawings.pdf	2024/04/30
1127 GC Legal Notice.pdf	2024/04/30	1127-GC Addendum 2-2024.04.30 Civil Drawings.pdf	2024/04/30
1127 GC Legal Notice.pdf	2024/04/30	1127-gc Prebid-RFI-010 GC [R].pdf	2024/05/22
1127 GC Legal Notice.pdf	2024/05/01	1127-gc Prebid-RFI-007 GC [R] (1).pdf	2024/05/22
		1127-GC Addendum #4 2024.05.08 Architectural Drawings Addendum 03.pdf	2024/05/22
		1127-GC Addendum #3 23.0014 - Albany Aiport Terminal A_RGE_Geotech Report.pdf	2024/05/22
		1127-GC Addendum #4 FAA Form 5100 136 Buy American Worksheet.pdf	2024/04/30
		1127-GC Addendum 02 Cover Sheet.pdf	2024/05/22
		1127-gc Addendum 05 28 2000 BSD-Video Surveillance.pdf	2024/05/22
		1127-gc Terminal A Pay Schedule Of Values (Sample).pdf	2024/05/22
		1127-GC Addendum 2-2024.04.30 Architectural Drawings.pdf	2024/04/30
		1127-GC Addendum 2-2024.04.30 Architectural Drawings.pdf	2024/04/30
		1127-GC Addendum #3 Prebid-RFI-003 GC R.pdf	2024/05/22
		1127-gc addAddendum	2024/05/22

05 26 2726 BSD- Wiring Devices.pdf	2024/05/24
1127-gc Addendum 07 Prebid-RFI-015 GC [R].pdf	2024/04/30
1127-gc Pre-bid Attendees.pdf	2024/04/30
1127-gc Pre-bid Attendees.pdf	2024/05/23
1127 GC Addendum 06 cover sheet.pdf	2024/05/23
1127-GC Addendum 06 drawings.pdf	2024/05/24
1127-gc Addendum 07 Door Hardware.pdf	2024/04/30
1127-GC Addendum 2- PREBID-RFI-001 GC R.pdf	2024/04/30
1127-GC Addendum 2- PREBID-RFI-001 GC R.pdf	2024/05/22
1127-gc Addendum 05 Civil Drawings.pdf	2024/05/22
1127-gc Addendum 05 28 1000 BSD- Access Control.pdf	2024/05/24
1127-gc Addendum 07 Prebid-RFI-012 GC [R].pdf	2024/05/24
1127-GC Addendum 07 Bid Form R2.pdf	2024/05/24
1127-gc Addendum 07 Architectural Drawings.pdf	2024/05/23
1127 gc Addendum 06.pdf	2024/04/30
1127-GC Addendum #1 cover sheet.pdf	2024/05/24
1127-gc Addendum 07 Cover Sheet.pdf	2024/05/22
1127-GC Addendum #3 Prebid-RFI-005 GC R.pdf	2024/05/22
1127-gc Addendum 05 Structural Drawings.pdf	2024/05/22
1127-gc Addendum 05 Cover Sheet.pdf	2024/05/24
1127-gc Addendum 07 Prebid-RFI-013 GC [R].pdf	2024/05/22
1127-gc Prebid- RFI-008 GC [R].pdf	2024/05/22
1127-GC Addendum #4 2024.04.08 Mechanical Drawings Addendum 03.pdf	2024/05/22
1127-gc Prebid- RFI-006 GC [R] (1).pdf	2024/05/22

													1127-GC Addendum #3 Prebid-RFI-004 GC R.pdf	2024/05/22
													1127-GC Addendum #3 Cover Sheet.pdf	2024/05/22
													1127-GC Addendum #3 2024. Architectural Drawing A441 Addendum 03.pdf	2024/05/22
NY TENT, LLC	110 Wilbur Place	Bohemia	NY	David Tannenbaum	6319799182	RFP@industrialstructuresolutions.com	Partial 1/45	David Tannenbaum	6319799182	RFP@industrialstructuresolutions.com	2024.04.10 100% CD Drawings.pdf	2024/04/24		
New York State Department of Labor	Harriman State Office Campus, 1220 Washington Ave., Bldg 12, Room 134B	Albany	NY	James H.Kilby	518-485-9072	james.kilby@labor.ny.gov	Full 8/45	James H.Kilby	518-485-9072	james.kilby@labor.ny.gov			1127-GC Pre-bid Attendees.pdf	2024/04/30
													1127-GC Addendum 2- PREBID-RFI-001 GC R.pdf	2024/04/30
													1127-GC Addendum #4 2024.05.08 Architectural Drawings Addendum 03.pdf	2024/05/14
													1127-GC Addendum 2- 2024.04.30 Civil Drawings.pdf	2024/04/30
													1127-GC Pre Bid Meeting Agenda Final.pdf	2024/04/30
													1127-GC Addendum 2- 2024.04.30 Architectural Drawings.pdf	2024/04/30
													1127-GC Addendum 02 Cover Sheet.pdf	2024/04/30
													1127-GC Addendum #1 cover sheet.pdf	2024/04/30
North America Procurement Council, Inc. PBC	PO Box 40445	Grand Junction	CO	Tim Loncarich	302-450-1923	bidnet@nadc.me	Full 7/45	Tim Loncarich	302-450-1923	bidnet@nadc.me	Rehabilitation on Concourse A.pdf	2024/04/18	1127-GC Addendum #1 cover sheet.pdf	2024/04/25
Name	Address	City	State/Prov	Name	Phone	Email		Name	Phone	Email	Document	Download Date	Document	Download Date
North America Procurement Council, Inc. PBC	PO Box 40445	Grand Junction	CO	Tim Loncarich	302-450-1923	bidnet@nadc.me	Full 7/45	Tim Loncarich	302-450-1923	bidnet@nadc.me	1127-GC Addendum #4 2024.05.08 Architectural Drawings Addendum 03.pdf	2024/04/18	1127-GC Addendum #4 2024.05.08 Architectural Drawings Addendum 03.pdf	2024/05/10
											1127 GC Legal Notice.pdf	2024/04/18	1127-GC Addendum 02 Cover Sheet.pdf	2024/04/30
													1127-GC Addendum #3 Cover Sheet.pdf	2024/05/09
O'Connell Electric Company	2360 Maxon Rd Extension	Schenectady	NY	Casey Sumner	518-612-8215	casey.sumner@oconnellelectric.com	Partial 10/45	Casey Sumner	518-612-8215	casey.sumner@oconnellelectric.com	1127 GC Legal Notice.pdf	2024/05/03	1127-GC Addendum 02 Cover Sheet.pdf	2024/05/03
											1127 GC Legal Notice.pdf	2024/05/03	1127-GC Addendum 2- PREBID-RFI-001 GC R.pdf	2024/05/03
											2024.04.10 100% CD Drawings.pdf	2024/05/03	1127-GC Addendum #1 cover sheet.pdf	2024/05/03
											Rehabilitation on Concourse A.pdf	2024/05/03	1127-GC Pre-bid Attendees.pdf	2024/05/03

											Rehabilitation on Concourse A.pdf	2024/05/03	1127-GC Addendum 2-2024.04.30 Architectural Drawings.pdf	2024/05/03
													1127-GC Addendum 2-2024.04.30 Civil Drawings.pdf	2024/05/03
Osiristone	9 Hancock St, 1	Staten Island	NY	ismai Sall	(929)363-3601	osiristone@outlook.com	Partial 1/45	ismai Sall	(929)363-3601	osiristone@outlook.com	2024.04.10 100% CD Drawings.pdf	2024/04/18		
PHLY	1 Lakeshore Ctr, Ste 300	Bridgewater	MA	Harry Ungeheuer	781-297-6568	hbu518@gmail.com	Full 7/45	Harry Ungeheuer	781-297-6568	hbu518@gmail.com	1127 GC Legal Notice.pdf	2024/05/08	1127-GC Pre Bid Meeting Agenda Final.pdf	2024/05/08
											Rehabilitation on Concourse A.pdf	2024/05/08	1127-GC Addendum #1 cover sheet.pdf	2024/05/08
											2024.04.10 100% CD Drawings.pdf	2024/05/08	1127-GC Pre-bid Attendees.pdf	2024/05/08
													1127-GC Addendum 02 Cover Sheet.pdf	2024/05/08
Parlor City Group LLC	4301 Vestal Rd	Vestal	NY	Maximilian Bixner	607-366-0707	maxx@parforcityfurniture.com	Full 6/45	Maximilian Bixner	607-366-0707	maxx@parforcityfurniture.com	2024.04.10 100% CD Drawings.pdf	2024/05/15	1127-GC Addendum #4 2024.05.08 Architectural Drawings Addendum 03.pdf	2024/05/15
											Rehabilitation on Concourse A.pdf	2024/05/15	1127-GC Addendum #4 FAA Form 5100 136 Buy American Worksheet.pdf	2024/05/15
													1127-GC Addendum #3 Cover Sheet.pdf	2024/05/15
													1127-GC Addendum #3 Prebid-RFI-002 GC R.pdf	2024/05/15
Peter Luizzi Bros Contracting Inc	857 1st Street	Watervliet	NY	Peter Luizzi	518-482-8954	enixon@luizzibros.com	Partial 3/45	Erin Nixon	518-482-8954	enixon@luizzibros.com	Rehabilitation on Concourse A.pdf	2024/04/22		
											1127 GC Legal Notice.pdf	2024/04/22		
											2024.04.10 100% CD Drawings.pdf	2024/04/22		
Plank LLC	376 Broadway, 3rd Floor	Schenectady	NY	Stephanie Poulin	5183445400	spoulin@plankllc.com	Partial 3/45	Eddie T.	5183445400 154	edt@plankllc.com	1127 GC Legal Notice.pdf	2024/04/18		
											Rehabilitation on Concourse A.pdf	2024/04/18		
											Rehabilitation on Concourse A.pdf	2024/05/09		
											2024.04.10 100% CD Drawings.pdf	2024/04/18		
											2024.04.10 100% CD Drawings.pdf	2024/05/09		
											2024.04.10 100% CD Drawings.pdf	2024/05/09		
Postler & Jaeckle Corp.	615 South Ave	Rochester	NY	Joseph JCamillaci	5854236272	jcamilaci@postler.com	Partial 2/45	Joseph JCamillaci	5854236272	jcamilaci@postler.com	Rehabilitation on Concourse A.pdf	2024/05/28	1127-GC Addendum 07 Bid Form R2.pdf	2024/05/28
Root Companies, LLC.	841 E. Fort Avenue	BALTIMORE	MD	Luis Martinez, Jr.	(410) 984-0000	luisjr@rootcompanies.com	Partial 3/45	Luis Martinez, Jr.	(410) 984-0000	luisjr@rootcompanies.com	1127 GC Legal Notice.pdf	2024/04/18		

Schenectady Hardware & Electric
 155 Erie Blvd. Schenectady NY
 Chris Kogut 5183462369 ckogut@sheinc.com

Partial 37/45 Chris Kogut 5183462369 ckogut@sheinc.com

2024.04.10 100% CD Drawings.pdf	2024/04/18		
2024.04.10 100% CD Drawings.pdf	2024/04/18		
2024.04.10 100% CD Drawings.pdf	2024/04/18		
2024.04.10 100% CD Drawings.pdf	2024/04/18		
2024.04.10 100% CD Drawings.pdf	2024/04/18		
2024.04.10 100% CD Drawings.pdf	2024/04/18		
2024.04.10 100% CD Drawings.pdf	2024/04/18		
Rehabilitation on Concourse A.pdf	2024/04/18		
Rehabilitation on Concourse A.pdf	2024/04/18		
2024.04.10 100% CD Drawings.pdf	2024/04/18	1127-GC Addendum #3 Prebid-RFI-005 GC R.pdf	2024/05/09
2024.04.10 100% CD Drawings.pdf	2024/04/18	1127-gc Addendum 05 Cover Sheet.pdf	2024/05/22
Rehabilitation on Concourse A.pdf	2024/04/18	1127-GC Addendum #4 2024.04.08 Mechanical Drawings Addendum 03.pdf	2024/05/09
1127 GC Legal Notice.pdf	2024/04/18	1127-gc addAddendum 05 26 27 26 BSD- Wiring Devices.pdf	2024/05/22
		1127-gc Prebid- RFI-009R1 GC [R].pdf	2024/05/22
		1127-GC Addendum #3 Prebid-RFI-002 GC R.pdf	2024/05/09
		1127-GC Pre Bid Meeting Agenda Final.pdf	2024/04/25
		1127-gc Addendum 05 Electrical Drawings.pdf	2024/05/22
		1127-GC Addendum #4 2024.05.08 Architectural Drawings Addendum 03.pdf	2024/05/09
		1127-GC Addendum 2- PREBID-RFI-001 GC R.pdf	2024/05/01
		1127-gc Addendum 05 Civil Drawings.pdf	2024/05/22
		1127-GC Addendum #3 23.0014 - Albany Airport Terminal A_RGE_Geotech Report.pdf	2024/05/09
		1127-gc Addendum 05 28 2000 BSD-Video Surveillance.pdf	2024/05/22
		1127-GC Addendum #3 Cover Sheet.pdf	2024/05/09

Name Schenectady Hardware & Electric	Address 155 Erie Blvd.	City Schenectady	State/Prov NY	Name Chris Kogut	Phone 5183462369	Email ckogul@sheinc.com	Partial 37/45	Name Chris Kogut	Phone 5183462369	Email ckogul@sheinc.com	Document	Download Date
											1127-gc Prebid-RFI-011R1 GC [R].pdf	2024/05/22
											Addendum #3 Architectural Drawing A44 1 Addendum 03.pdf	2024/05/09
											1127-GC Addendum #3 Prebid-RFI-003 GC R.pdf	2024/05/09
											1127 GC Addendum 06 cover sheet.pdf	2024/05/22
											1127 GC Addendum 06 cover sheet.pdf	2024/05/22
											1127 GC Addendum 06 cover sheet.pdf	2024/05/22
											1127-GC Addendum 06 drawings.pdf	2024/05/22
											1127-GC Addendum 06 drawings.pdf	2024/05/22
											1127-GC Addendum 06 drawings.pdf	2024/05/22
											1127-gc Terminal A Pay Schedule (Sample).pdf	2024/05/22
											1127-gc Prebid-RFI-006 GC [R] (1).pdf	2024/05/22
											1127 gc Addendum 06.pdf	2024/05/22
											1127 gc Addendum 06.pdf	2024/05/22
											1127 gc Addendum 06.pdf	2024/05/22
											1127-GC Addendum 2-2024.04.30 Civil Drawings.pdf	2024/05/01
											1127-GC Addendum #1 cover sheet.pdf	2024/04/25
											1127-GC Addendum 02 Cover Sheet.pdf	2024/05/01
											1127-GC Pre-bid Attendees.pdf	2024/04/25
											1127-GC Pre-bid Attendees.pdf	2024/04/25
											1127-gc Addendum 05 Structural Drawings.pdf	2024/05/22
											1127-GC Addendum #3 Prebid-RFI-004 GC R.pdf	2024/05/09
											1127-gc Prebid-RFI-007 GC [R] (1).pdf	2024/05/22
											1127-GC Addendum #4 FAA Form 5100 136 Buy American Worksheet.pdf	2024/05/09
											1127-gc Addendum 05 28 1000 BSD.	2024/05/22

												Access Control.pdf		
												1127-GC Addendum 2-2024.04.30 Architectural Drawings.pdf	2024/05/01	
												1127-gc Prebid-RFI-010 GC [R].pdf	2024/05/22	
												1127-gc Prebid-RFI-008 GC [R].pdf	2024/05/22	
Stilsing Electric Inc	500 South ST	Rensselaer	NY	Michael LStilsing	518-463-4451 110	mstilsing@stilsingelectric.com	Partial 1/45	Michael LStilsing	518-463-4451 110	mstilsing@stilsingelectric.com	2024.04.10 100% CD Drawings.pdf	2024/04/22		
Swan Contracting LLC	409 Old Niskayuna Road	Latham	NY	Kelly Prins	518-461-9414	kprins@swan2b.com	Partial 4/45	Kelly Prins	518-461-9414	kprins@swan2b.com	Rehabilitation on Concourse A.pdf	2024/04/23	1127-GC Pre-bid Attendees.pdf	2024/04/30
											2024.04.10 100% CD Drawings.pdf	2024/04/23	1127-GC Pre-bid Attendees.pdf	2024/04/30
											1127 GC Legal Notice.pdf	2024/04/23		
The Metro Group, Inc.	650 Mile Crossing Blvd, Suite #4	Rochester	NY	Mark Botsford	315-345-2437	mbotsford@metrogroupinc.com	Partial 1/45	Mark Botsford	315-345-2437	mbotsford@metrogroupinc.com	Rehabilitation on Concourse A.pdf	2024/04/19		
The VMJR Companies	73 Mohican Street	Glens Falls	NY	Estimating Department	(518) 792-1128 111	bidinfo@vmjrcompanies.com	Full 45/45	Estimating Department	(518) 792-1128 111	bidinfo@vmjrcompanies.com	2024.04.10 100% CD Drawings.pdf	2024/04/23	1127-gc Addendum 05 Civil Drawings.pdf	2024/05/21
											Rehabilitation on Concourse A.pdf	2024/04/23	1127-gc Addendum 05 Civil Drawings.pdf	2024/05/21
											Rehabilitation on Concourse A.pdf	2024/05/02	1127-gc Addendum 05 Civil Drawings.pdf	2024/05/21
											1127 GC Legal Notice.pdf	2024/04/23	1127-gc Addendum 05 Civil Drawings.pdf	2024/05/21
													1127-gc Addendum 05 Electrical Drawings.pdf	2024/05/21
													1127-gc Addendum 05 Electrical Drawings.pdf	2024/05/22
													1127-GC Addendum 2-2024.04.30 Architectural Drawings.pdf	2024/05/02
													1127-GC Addendum 07 Bid Form R2.pdf	2024/05/24
													1127-GC Addendum 06 drawings.pdf	2024/05/22
													1127-GC Addendum 06 drawings.pdf	2024/05/22
													1127-gc Prebid-RFI-006 GC [R] (1).pdf	2024/05/21
													1127-gc Prebid-RFI-006 GC [R] (1).pdf	2024/05/21
													1127-GC Addendum #3 Prebid-RFI-003 GC R.pdf	2024/05/09
													1127-GC Pre-bid Attendees.pdf	2024/05/02
													1127-gc Addendum 07 Door Hardware.pdf	2024/05/24
													1127-gc Addendum 07	2024/05/24

Name	Address	City	State/Prov	Name	Phone	Email	Name	Phone	Email	Document	Download Date
The VMJR Companies	73 Mohican Street	Glens Falls	NY	Estimating Department	(518) 792-1128	bidinfo@vmjcompanies.com	Estimating Department	(518) 792-1128	bidinfo@vmjcompanies.com	Cover Sheet.pdf	2024/05/21
										1127-gc Terminal A Pay Schedule OI Values (Sample).pdf	2024/05/21
										1127-gc Terminal A Pay Schedule OI Values (Sample).pdf	2024/05/21
										1127 GC Addendum 06 cover sheet.pdf	2024/05/22
										1127-gc Addendum 07 Architectural Drawings.pdf	2024/05/24
										1127-GC Addendum #3 Cover Sheet.pdf	2024/05/09
										1127-gc Addendum 07 Prebid-RFI-013 GC [R].pdf	2024/05/24
										1127-gc Prebid-RFI-011R1 GC [R].pdf	2024/05/21
										1127-gc Prebid-RFI-011R1 GC [R].pdf	2024/05/21
										Document	Download Date
										1127-GC Addendum #4 FAA Form 5100 136 Buy American Worksheet.pdf	2024/05/09
										1127-GC Addendum #4 FAA Form 5100 136 Buy American Worksheet.pdf	2024/05/09
										1127-GC Addendum #4 FAA Form 5100 136 Buy American Worksheet.pdf	2024/05/09
										1127-GC Addendum #3 23.0014 - Albany Airport Terminal A_RGE_Geotech Report.pdf	2024/05/02
										1127-GC Addendum 2- PREBID-RFI-001 GC R.pdf	2024/05/21
										1127-gc Addendum 05 28 1000 BSD- Access Control.pdf	2024/05/21
										1127-gc Addendum 05 28 1000 BSD- Access Control.pdf	2024/05/21
										1127/0gc Addendum 07 Prebid-RFI-012 GC [R].pdf	2024/05/24
										1127-gc Addendum 07 Prebid-RFI-015 GC [R].pdf	2024/05/24
										1127-GC Addendum #1 cover sheet.pdf	2024/05/02
										1127-GC Addendum #3 Prebid-RFI-002 GC R.pdf	2024/05/09
										1127-gc Prebid-RFI-009R1 GC	2024/05/21

IRI.pdf	
1127-gc Probid-RFI-009R1 GC	2024/05/21
IRI.pdf	
1127 gc Addendum 06.pdf	2024/05/22
1127-GC Addendum #3 Probid-RFI-005 GC R.pdf	2024/05/09
1127-gc addAddendum 05 26 2726 BSD-Wiring Devices.pdf	2024/05/21
1127-gc addAddendum 05 26 2726 BSD-Wiring Devices.pdf	2024/05/21
1127-GC Addendum #3 2024, Architectural Drawing A441 Addendum 03.pdf	2024/05/09
1127-GC Addendum #4 2024.04.08 Mechanical Drawings Addendum 03.pdf	2024/05/09
1127-GC Addendum #4 2024.04.08 Mechanical Drawings Addendum 03.pdf	2024/05/09
1127-GC Addendum #4 2024.04.08 Mechanical Drawings Addendum 03.pdf	2024/05/09
1127-GC Addendum #4 2024.04.08 Mechanical Drawings Addendum 03.pdf	2024/05/09
1127-GC Addendum #4 2024.04.08 Mechanical Drawings Addendum 03.pdf	2024/05/09
1127-GC Addendum #4 2024.05.08 Architectural Drawings Addendum 03.pdf	2024/05/09
1127-GC Addendum #4 2024.05.08 Architectural Drawings Addendum 03.pdf	2024/05/09
1127-GC Addendum #4 2024.05.08 Architectural Drawings Addendum 03.pdf	2024/05/09
1127-gc Addendum 05 Cover Sheet.pdf	2024/05/21

Company	Address	City	State	Name	Phone	Partial	Contract #	Contract Description	Start Date	End Date	Document Title
The Vanalstyne Company & Supply	2604 Elmwood Avenue	Rochester	NY	Alan Lott	5857814707	Partial 1/45	5857814707	Rehabilitation on Concourse A.pdf	2024/04/18	2024/05/21	1127-gc Addendum 05 Cover Sheet.pdf
						Partial 2/45	3154160682	Rehabilitation on Concourse A.pdf	2024/04/18	2024/05/21	1127-gc Addendum 07 Prebid-RFI-014 GC [R].pdf
Tri-State Clearing & Tree Service	2388 Olmstead Rd	Bloomfield	NY	Hunter Bruner	3154160682	Full 8/45	518-432-0277	Rehabilitation on Concourse A.pdf	2024/04/24	2024/05/21	1127-gc Prebid-RFI-010 GC [R].pdf
						Full 8/45	518-432-0277	Rehabilitation on Concourse A.pdf	2024/04/24	2024/05/21	1127-gc Prebid-RFI-010 GC [R].pdf
Turner Construction Company	1 Computer Drive South	Albany	NY	Jen Robbins	518-432-0277	Full 8/45	518-432-0277	Rehabilitation on Concourse A.pdf	2024/04/24	2024/05/21	1127-gc Prebid-RFI-010 GC [R].pdf
						Full 8/45	518-432-0277	Rehabilitation on Concourse A.pdf	2024/04/24	2024/05/21	1127-gc Prebid-RFI-010 GC [R].pdf
The Vanalstyne Company & Supply	2604 Elmwood Avenue	Rochester	NY	Alan Lott	5857814707	Partial 1/45	5857814707	Rehabilitation on Concourse A.pdf	2024/04/18	2024/05/21	1127-gc Addendum 05 Cover Sheet.pdf
						Partial 2/45	3154160682	Rehabilitation on Concourse A.pdf	2024/04/18	2024/05/21	1127-gc Addendum 07 Prebid-RFI-014 GC [R].pdf
Tri-State Clearing & Tree Service	2388 Olmstead Rd	Bloomfield	NY	Hunter Bruner	3154160682	Full 8/45	518-432-0277	Rehabilitation on Concourse A.pdf	2024/04/24	2024/05/21	1127-gc Prebid-RFI-010 GC [R].pdf
						Full 8/45	518-432-0277	Rehabilitation on Concourse A.pdf	2024/04/24	2024/05/21	1127-gc Prebid-RFI-010 GC [R].pdf
Turner Construction Company	1 Computer Drive South	Albany	NY	Jen Robbins	518-432-0277	Full 8/45	518-432-0277	Rehabilitation on Concourse A.pdf	2024/04/24	2024/05/21	1127-gc Prebid-RFI-010 GC [R].pdf
						Full 8/45	518-432-0277	Rehabilitation on Concourse A.pdf	2024/04/24	2024/05/21	1127-gc Prebid-RFI-010 GC [R].pdf

Name	Address	City	State/Prov	Name	Phone	Email
VRH Construction	320 Grand Ave	Englewood	NJ	Timothy Karl	2018714422	Lkarl@vrhcorp.com

Full 45/45

Name	Phone	Email
Coleen DiGiorgio	201-871-4422	c.digiorgio@vrhcorp.com

Name	Phone	Email
Timothy Karl	2018714422	Lkarl@vrhcorp.com

Document	Download Date	Document	Download Date
1127 GC Legal Notice.pdf	2024/04/24	1127-GC Addendum #1 cover sheet.pdf	2024/05/26
1127 GC Legal Notice.pdf	2024/05/17	1127-GC Pre Bid Meeting Agenda Final.pdf	2024/04/26
		1127-GC Pre Bid Meeting Agenda Final.pdf	2024/05/26
1127 GC Legal Notice.pdf	2024/04/24	1127-GC Addendum 02 Cover Sheet.pdf	2024/04/30
Rehabilitation on Concourse A.pdf	2024/04/18		
Rehabilitation on Concourse A.pdf	2024/04/30		
Rehabilitation on Concourse A.pdf	2024/04/30		
Rehabilitation on Concourse A.pdf	2024/04/30		
1127 GC Legal Notice.pdf	2024/04/18	1127-gc Terminal A Pay Schedule Of Values (Sample).pdf	2024/05/21
2024.04.10 100% CD Drawings.pdf	2024/04/18	1127-GC Addendum #3 Prebid-RFI-005 GC R.pdf	2024/05/09
Rehabilitation on Concourse A.pdf	2024/04/18	1127-GC Addendum #3 Prebid-RFI-005 GC R.pdf	2024/05/21
		1127-gc Addendum 07 Cover Sheet.pdf	2024/05/24
		1127 gc Addendum 06.pdf	2024/05/22
		1127-gc Prebid-RFI-007 GC [R] (1).pdf	2024/05/21
		1127-GC Addendum #4 2024.04.08 Mechanical Drawings Addendum 03.pdf	2024/05/09
		1127-GC Addendum #4 2024.04.08 Mechanical Drawings Addendum 03.pdf	2024/05/21
		1127-gc Addendum 07 Architectural Drawings.pdf	2024/05/24
		1127-gc Prebid-RFI-008R1 GC [R].pdf	2024/05/21
		1127-gc Addendum 05 Structural Drawings.pdf	2024/05/21
		1127-gc Addendum 05 Structural Drawings.pdf	2024/05/21
		1127-GC Pre Bid Meeting Agenda	2024/04/25

Final.pdf	2024/04/25
1127-GC Pre Bid Meeting Agenda	2024/04/26
Final.pdf	
1127-GC Pre Bid Meeting Agenda	2024/05/21
Final.pdf	
1127-gc Addendum 05 28 1000 BSD-Access	
Control.pdf	
1127-gc addAddendum 05 26 2726 BSD-Wiring	
Devices.pdf	
1127-gc Addendum 05 Cover Sheet.pdf	
1127-gc Addendum 05 Cover Sheet.pdf	
1127-gc Addendum 05 Electrical Drawings.pdf	
1127-GC Addendum 2-2024.04.30 Architectural Drawings.pdf	
1127-GC Addendum 2-2024.04.30 Architectural Drawings.pdf	
1127 GC Addendum 06 cover sheet.pdf	
1127-GC Addendum #3 Prebid-RFI-002 GC R.pdf	
1127-GC Addendum #3 Prebid-RFI-002 GC R.pdf	
1127-gc Addendum 07 Prebid-RFI-013 GC [R].pdf	
1127-gc Prebid-RFI-006 GC [R] (1).pdf	
1127-GC Addendum #3 Prebid-RFI-003 GC R.pdf	
1127-GC Addendum #3 Prebid-RFI-003 GC R.pdf	
1127-GC Addendum #3 Prebid-RFI-003 GC R.pdf	
1127-GC Addendum #1 cover sheet.pdf	
1127-GC Addendum #1 cover sheet.pdf	
1127-GC Addendum #1 cover sheet.pdf	
1127-GC Addendum #1 cover sheet.pdf	

1127-gc Prebid- RFI-011R1 GC [R].pdf	2024/05/21
1127-gc Addendum 05 28 2000 BSD-Video Surveillance.pdf	2024/05/21
1127-GC Addendum 06 drawings.pdf	2024/05/22
1127-GC Addendum 2- PREBID-RFI-001 GC R.pdf	2024/04/30
1127-GC Addendum 2- PREBID-RFI-001 GC R.pdf	2024/05/21
1127-gc Addendum 07 Prebid-RFI-015 GC [R].pdf	2024/05/24
1127-GC Addendum #4 FAA Form 5100 136 Buy American Worksheet.pdf	2024/05/09
1127-GC Addendum #4 FAA Form 5100 136 Buy American Worksheet.pdf	2024/05/21
1127-gc Addendum 07 Prebid-RFI-014 GC [R].pdf	2024/05/24
1127-GC Addendum 2- 2024.04.30 Civil Drawings.pdf	2024/04/30
1127-GC Addendum 2- 2024.04.30 Civil Drawings.pdf	2024/04/30

Name	Address	City	State/Prov	Name	Phone	Email	Document	Download Date
VRH Construction	320 Grand Ave	Englewood	NJ	Timothy Karl	2018714422	L.karl@vrhcorp.com	1127-GC Addendum 2- 2024.04.30 Civil Drawings.pdf	2024/05/21
							1127-gc Addendum 07 Door Hardware.pdf	2024/05/24
							1127-GC Addendum #3 2024. Architectural Drawing A441 Addendum 03.pdf	2024/05/09
							1127-GC Addendum #3 2024. Architectural Drawing A441 Addendum 03.pdf	2024/05/21
							1127-GC Addendum #3 Cover Sheet.pdf	2024/05/10
							1127-GC Addendum #3 Cover Sheet.pdf	2024/05/10
							1127-GC Addendum #3 Cover Sheet.pdf	2024/05/21
							1127-GC Addendum #3 Cover Sheet.pdf	2024/05/21

1127-gc Prebid-RFI-010 GC [R].pdf	2024/05/21
1127-GC Addendum #4 2024.05.08 Architectural Drawings Addendum 03.pdf	2024/05/09
1127-GC Addendum #4 2024.05.08 Architectural Drawings Addendum 03.pdf	2024/05/21
1127-GC Addendum 02 Cover Sheet.pdf	2024/04/30
1127-GC Addendum 02 Cover Sheet.pdf	2024/05/21
1127-GC Addendum 02 Cover Sheet.pdf	2024/05/21
1127-GC Addendum 02 Cover Sheet.pdf	2024/05/21
1127-GC Addendum 02 Cover Sheet.pdf	2024/05/21
11270gc Addendum 07 Prebid-RFI-012 GC [R].pdf	2024/05/24
1127-gc Addendum 05 Civil Drawings.pdf	2024/05/21
1127-gc Addendum 05 Civil Drawings.pdf	2024/05/21
1127-gc Addendum 05 Civil Drawings.pdf	2024/05/21
1127-gc Addendum 05 Civil Drawings.pdf	2024/05/21
1127-gc Addendum 05 Civil Drawings.pdf	2024/05/21
1127-GC Addendum #3 23.0014 - Albany Airport Terminal A_RGE_Geotech Report.pdf	2024/05/09
1127-GC Addendum #3 23.0014 - Albany Airport Terminal A_RGE_Geotech Report.pdf	2024/05/21
1127-GC Addendum 07 Bid Form R2.pdf	2024/05/24
1127-GC Addendum #3 Prebid-RFI-004 GC R.pdf	2024/05/09
1127-GC Addendum #3 Prebid-RFI-004 GC R.pdf	2024/05/21

WM SCHULTZ CONSTRUCTION, INC. PO BOX 2620 BALLSTON SPA NY Kelly Schultz 5188850060 kschultz@wmschultz.com

Partial 3/45 Kelly Schultz 5188850060 kschultz@wmschultz.com

Rehabilitation on Concourse A.pdf	2024/04/18
Rehabilitation on Concourse A.pdf	2024/04/18
Rehabilitation on Concourse A.pdf	2024/04/19
2024.04.10 100% CD Drawings.pdf	2024/04/18

Western Industrial Contractors	25755 E 65th Ave	Aurora	CO	Lawrence Nau	3039154530	lnau@westerncon.com	Partial 10/45	Lawrence Nau	3039154530	lnau@westerncon.com	1127 GC Legal Notice.pdf	2024/04/18		
											2024.04.10 Drawings.pdf	2024/05/07	1127-GC Addendum 2-2024.04.30 Civil Drawings.pdf	2024/05/07
											2024.04.10 100% CD Drawings.pdf	2024/05/07	1127-GC Addendum 2-2024.04.30 Architectural Drawings.pdf	2024/05/07
											Rehabilitation on Concourse A.pdf	2024/05/07	1127-GC Pre-bid Attendees.pdf	2024/05/07
											Rehabilitation on Concourse A.pdf	2024/05/07	1127-GC Addendum 02 Cover Sheet.pdf	2024/05/07
Western Industrial Contractors, Inc.	14805 E Moncrieff Place	Aurora	CO	John Eddy	303-868-8739	jeddy@westerncon.com	Partial 14/45	John Eddy	303-868-8739	jeddy@westerncon.com	1127 GC Legal Notice.pdf	2024/05/07	1127-GC Addendum 2- PREBID-RFI-001 GC R.pdf	2024/05/07
											1127 GC Legal Notice.pdf	2024/05/07	1127-GC Pre Bid Meeting Agenda Final.pdf	2024/05/07
													1127-GC Addendum #1 cover sheet.pdf	2024/05/07
													1127-gc Addendum 07 Prebid-RFI-015 GC [R].pdf	2024/05/24
													1127-gc Addendum 07 Prebid-RFI-014 GC [R].pdf	2024/05/24
													1127-GC Addendum 02 Cover Sheet.pdf	2024/05/24
													1127-GC Pre-bid Attendees.pdf	2024/05/24
													1127-GC Addendum #3 Prebid-RFI-002 GC R.pdf	2024/05/09
													1127-GC Addendum #3 Cover Sheet.pdf	2024/05/09
													1127-GC Addendum #3 23.0014 - Albany Airport Terminal A_RGE_Geotech Report.pdf	2024/05/09
		1127-GC Addendum #3 Prebid-RFI-003 GC R.pdf	2024/05/09											
		1127-GC Addendum #4 FAA Form 5100 136 Buy American Worksheet.pdf	2024/05/09											
		1127-GC Addendum #3 Prebid-RFI-005 GC R.pdf	2024/05/09											
		1127-GC Addendum #3 Prebid-RFI-004 GC R.pdf	2024/05/09											
		1127-GC Addendum #3 2024. Architectural Drawing A441 Addendum 03.pdf	2024/05/09											
		1127-GC Addendum #4 2024.05.08 Architectural Drawings	2024/05/09											

Name	Address	City	State/Prov	Name	Phone	Email	Partial	Name	Phone	Email	Document	Download Date	Document	Download Date
champion M&S	100 Owens rd	Brockport	NY	Scott Smith	585 235 3500 310	scotts@champion-moving.com	Partial 2/45	Scott Smith	585 235 3500 310	scotts@champion-moving.com			Addendum 03.pdf	2024/05/24
													Addendum #1 cover sheet.pdf	2024/05/24
													Addendum 07 Probid-RFI-014 GC [R].pdf	2024/05/22
													1127-gc Prebid-RFI-010 GC [R].pdf	2024/05/22
if managment group CORP.	35 s main st , unit 841	pearl river	NY	Felix Castillo	6467859585	castilofelix@live.com	Partial 1/45	Felix Castillo	6467859585	castilofelix@live.com	2024.04.10 100% CD Drawings.pdf	2024/04/18		
metals 2000 inc	254 E 68th St	NEW YORK	NY	Eliot Rusoff	8004541323	lisa@metals2000.com	Partial 3/45	Eliot Rusoff	8004541323	lisa@metals2000.com	2024.04.10 100% CD Drawings.pdf	2024/04/22		
											2024.04.10 100% CD Drawings.pdf	2024/04/22		
											2024.04.10 100% CD Drawings.pdf	2024/04/22		
											2024.04.10 100% CD Drawings.pdf	2024/04/22		
											1127 GC Legal Notice.pdf	2024/04/22		
											1127 GC Legal Notice.pdf	2024/04/22		
											1127 GC Legal Notice.pdf	2024/04/22		
											Rehabilitation on Concourse A.pdf	2024/04/22		
											Rehabilitation on Concourse A.pdf	2024/04/22		
											Rehabilitation on Concourse A.pdf	2024/04/22		

CO.NAME:
ADDRESS:
CITY,STATE,ZIP:
PHONE:
FAX:
CONTACT PERSON:
DATE OF PICK-UP:
CHECK#:
E-MAIL:
AFFIRMATION SIGNED:

CO.NAME:
ADDRESS:
CITY,STATE,ZIP:
PHONE:
FAX:
CONTACT PERSON:
DATE OF PICK-UP:
CHECK#:
E-MAIL:
AFFIRMATION SIGNED:

CO.NAME:
ADDRESS:
CITY,STATE,ZIP:
PHONE:
FAX:
CONTACT PERSON:
DATE OF PICK-UP:
CHECK#:
E-MAIL:
AFFIRMATION SIGNED:

CO.NAME:
ADDRESS:
CITY,STATE,ZIP:
PHONE:
FAX:
CONTACT PERSON:
DATE OF PICK-UP:
CHECK#:
E-MAIL:
AFFIRMATION SIGNED:

CO.NAME:
ADDRESS:
CITY,STATE,ZIP:
PHONE:
FAX:
CONTACT PERSON:
DATE OF PICK-UP:
CHECK#:
E-MAIL:
AFFIRMATION SIGNED:

CO.NAME:
ADDRESS:
CITY,STATE,ZIP:
PHONE:
FAX:
CONTACT PERSON:
DATE OF PICK-UP:
CHECK#:
E-MAIL:
AFFIRMATION SIGNED:

CO.NAME:
ADDRESS:
CITY,STATE,ZIP:
PHONE:
FAX:
CONTACT PERSON:
DATE OF PICK-UP:
CHECK#:
E-MAIL:
AFFIRMATION SIGNED:

CO.NAME:
ADDRESS:
CITY,STATE,ZIP:
PHONE:
FAX:
CONTACT PERSON:
DATE OF PICK-UP:
CHECK#:
E-MAIL:
AFFIRMATION SIGNED:

PRE-BID

4/25/2024

CONTRACT #1127-GC

11:00 A.M.

Rehabilitation of Concourse A

ATTENDEES

Co. Name Murnane Building Contractors, Inc
Phone 518-764-4317
Contact John Matrizzo
Email Jmatrizzo@murnanebuilding.com

Co. Name MLB CONSTRUCTION
Phone 518-289-1271
Contact OLEG SMOLOVIK
Email osmolovik@mlbind.com

Co. Name ~~Attila Bernhardt~~ Kolcolakis Contracting
Phone 631 767 9038
Contact Nicholas Bernhardt
Email nbernhardt@JKolcolakis.com

Co. Name LeChase Construction
Phone ~~518 831 977~~ 518-388-9200
Contact Scott Lawler
Email scott.lawler@lechase.com

Co. Name JMSR Co.
Phone 518-338-1262
Contact Marc Murray
Email bid info @jmsrcompanies.com

Co. Name MARTIN ELECTRIC
Phone 518-788-1532
Contact PAT GALGAY
Email Pgalgay@martinelectric.com

Co. Name Fennick McCredie Architecture
Phone 617 350 7900
Contact Melissa Vaillancourt
Email mvallancourt@farchitecture.com

Co. Name McFARLAND JOHNSON
Phone 518-580-9380
Contact TURNER BRADFORD
Email TBRADFORD@MSINC.COM

Co. Name KOKOLAKIS CONTRACTING
Phone (518) 728-0127
Contact Aaron Reamer
Email areamer@jkokolakis.com

Co. Name VRH
Phone 518 475 8629
Contact TIM KARL
Email T.KARL@VRHcorp.com.

Co. Name VRH
Phone 201-321-2520
Contact TALEH NASIB
Email T.nasib@vrhcorp.com

Co. Name AOW
Phone 518-482-3400
Contact Al Burgazoli
Email aburgazoli@aowconstruction.com

Co. Name LEE ECK DC 9
Phone 518.248.6487
Contact LEE ECK
Email leek@dc9.net

Co. Name DC 9
Phone 646.423.2367
Contact JEFF LAFONTAINE
Email jlafontaine@dc9.net

Co. Name _____
Phone _____
Contact _____
Email _____

Co. Name _____
Phone _____
Contact _____
Email _____

Co. Name _____
Phone _____
Contact _____
Email _____



June 27th, 2024

By electronic transmittal

Mr. Ralph Gatto, Airport Engineer
FAA New York Airports District Office
One Aviation Plaza, Suite 111
Jamaica, New York 11434

**Re: Request for Reimbursement of Eligible ALB Terminal A Reconstruction (33,000 SF);
New A1 & A2 PBBs; New Companion Restroom Design Service Costs**

Dear Mr. Gatto:

I am writing to respectfully request reimbursement of design service expenses as related to the ALB Terminal A Reconstruction (33,000 SF); New A1 & A2 PBBs; New Companion Restroom project included under the associated BIL-ATP grant application. It is understood that eligible design expenses are directly related to the improvements that are considered eligible under the BIL-ATP grant and have been incurred after November 15, 2021.

I have included the original January 2023 design services agreement between Albany County Airport Authority and Fennick McCredie Architecture, Ltd. The reimbursable amount is estimated to be \$1,195,363.00. Additional documentation and invoices can be provided as requested.

Please extend our gratitude to your staff for the excellent assistance associated with our capital improvement projects. Please do not hesitate to call Chief Airport Planner, Connor Haskin of my staff at (518) 242-2239 if you require any additional information or assistance.

Sincerely,

Philip F. Calderone

Philip F. Calderone, Esq.,
Chief Executive Officer

cc: Rob Costa, FAA NYADO
Christine Quinn, ACAA
Michael Zonsius, ACAA
John LaClair, ACAA
Margaret Herrmann, ACAA
Connor Haskin, ACAA

**PROFESSIONAL SERVICES AGREEMENT
BETWEEN THE

ALBANY COUNTY AIRPORT AUTHORITY
AND
FENNICK McCREIDIE ARCHITECTURE, LTD

FOR THE
REHABILITATION OF CONCOURSE A

AT THE ALBANY INTERNATIONAL AIRPORT

CONTRACT NO. S-22-1127**

THIS AGREEMENT is made and entered into effective the 13th day of January, 2023, by and between the **ALBANY COUNTY AIRPORT AUTHORITY** (the "Authority"), a body corporate and politic constituting a public benefit corporation established and existing pursuant to the Albany County Airport Authority Act enacted by Chapter 686 of the laws of 1993 and set forth in Title 32 of the New York Public Authorities Law, having offices at the Albany International Airport, 737 Albany Shaker Road, Main Terminal, 3rd Floor, Albany, NY, 12211 and Fennick McCredie Architecture, LTD, (the "Consultant"), a **Massachusetts Corporation** having its office and principal place of business at 70 Franklin Street, Boston, Massachusetts 02110.

RECITALS

1. The County of Albany (the "County") is the owner of the Albany International Airport (the "Airport"), located in the Town of Colonie, County of Albany, State of New York.
2. The County and the Authority have entered into an Airport Lease Agreement, effective as of May 16, 1996, for a term expiring December 31, 2049, whereby the AUTHORITY has the exclusive right to operate, maintain and improve the Airport and do anything else permitted by law, subject only to the restrictions and conditions stated in such Airport Lease Agreement and in accordance with applicable law.
3. The Consultant has heretofore submitted a proposal, dated August 18, 2022, for the project entitled Rehabilitation of Concourse A.
4. The Authority has negotiated a scope of work with the Consultant as described herein.
5. This Agreement had been duly authorized by the Albany County Airport Authority by resolution adopted on December 5, 2022.

NOW THEREFORE, in consideration of the mutual covenants contained herein, the parties hereto agree as follows:

ARTICLE I - SERVICES TO BE PERFORMED

The Consultant shall perform the services hereinafter set forth under Article II, entitled "Scope of Work" during the period from execution of this Agreement until completion of the work, as described in Article XIII, hereof.

ARTICLE II - SCOPE OF WORK

The Authority agrees to and hereby does retain and employ the service of the Consultant because of its ability and reputation, and the Consultant agrees to perform such service of said project being particularly described in the Scope of Work, attached as **SCHEDULE "A"** hereto, and made a part hereof.

ARTICLE III - FEES

In consideration of the terms and obligations of this Agreement, the Authority agrees to pay and the Consultant agrees to accept as full compensation for all services rendered under this Agreement those costs for work actually performed in accordance with the "Fee Schedule" attached as **SCHEDULE "B"** hereto, and made a part hereof.

Consultant's fees in the aggregate shall not exceed \$1,195,363.00.

Payment of fees shall be made upon proper completion of a Claim Form by the Consultant. The Claim Form is set forth at the end of Schedule "B", Fee Schedule. Payment by the Authority to the Consultant shall be due and payable within thirty (30) days of receipt of a complete, accurate and acceptable Claim Form by the Authority. The Authority shall retain five percent (5%) of each payment until 100% completion of the work by Consultant. Upon completion of 100% of the work by the Consultant, and acceptance of such work by the Authority, the Consultant shall be entitled to any amounts retained by the Authority hereunder.

ARTICLE IV - AVAILABLE DATA

All technical or other data relative to the work in the possession of the Authority or in possession of the Consultant shall be made available to either party without expense.

ARTICLE V - COOPERATION

The Consultant shall cooperate with representatives, agents and employees of the Authority and the Authority shall cooperate with the Consultant to the end that work may proceed expeditiously and economically.

ARTICLE VI - EXTRA WORK

If the Consultant is of the opinion that any work the Consultant has been directed to perform is beyond the scope of this Agreement and constitutes Extra Work, the Consultant shall promptly notify the Authority in writing of the fact. The Authority shall be the sole judge as to whether or not such work is in fact beyond the scope of this Agreement and whether or not it constitutes Extra Work. In the event that the Authority determines in writing that such work does constitute Extra Work, it shall provide extra compensation to the Consultant on a negotiated basis.

ARTICLE VII - ACCOUNTING RECORDS

Proper and full accounting records shall be maintained by the Consultant, which records shall clearly identify the costs of the work performed under this Agreement. Such records shall be subject to periodic and final audit by the Authority upon request. Such records shall be accessible to the Authority for a period of six (6) years following the date of final payment by the Authority to the Consultant for the performance of the work contemplated herein.

ARTICLE VIII - ASSIGNMENTS

The Consultant specifically agrees as required by Section 109 of the New York General Municipal Law that the Consultant is prohibited from assigning, transferring, conveying, sub-contracting, or otherwise disposing of this Agreement, or of Consultant's right, title or interest therein without the previous consent, in writing, of the Authority.

ARTICLE IX - OWNERSHIP OF MATERIALS

All rights, titles and ownership in and to all materials prepared under the provision of this Agreement shall be in the Authority including the right of republication.

ARTICLE X - INDEPENDENT CONTRACTOR

The Consultant, in accordance with its status as an independent contractor, covenants and agrees that it will conduct itself consistent with such status, that it will neither hold itself out as, nor claim to be an agent, employee, or otherwise of the Authority by reason hereof, and that it will not, by reason hereof, make for itself, its representatives, or employees, any claim, demand or application to or for any right or privilege applicable to an agent, employee, or otherwise of the Authority, including, but not limited to Workman's Compensation coverage, Unemployment Insurance benefits, Social Security coverage, or Retirement membership or credit.

ARTICLE XI - INDEMNIFICATION

The Consultant shall indemnify and save harmless the Authority, its employees and agents, including the County of Albany, the Federal Aviation Administration, the State of New York and AFCO AvPorts Management, LLC, from and against all claims, damages, losses and expenses (including, without limitation, reasonable attorney's fees) arising out of, or in consequence of, any negligent act or omission or intentional act of the Consultant, to the extent of their responsibility for such claims, damages, losses and expenses and to the fullest extent as possible by law.

ARTICLE XII - INSURANCE

The CONSULTANT shall procure and maintain at its own expense and without direct expense to the AUTHORITY until final acceptance by the AUTHORITY of the services covered by this Agreement, insurance policies of the kinds and the amounts hereafter provided, issued by insurance companies **licensed** by New York State and having an **A.M. Best rating of "A" or better**, covering all operations under this Agreement, whether performed by the CONSULTANT or by sub-contractors. Before commencing the work, the CONSULTANT shall furnish the AUTHORITY a certificate or certificates, in a form satisfactory to the AUTHORITY, showing that it has complied with these requirements, which certificate or certificates shall provide that the policies shall be automatically renewed and not be materially changed or canceled until thirty (30) days' written notice has been mailed to the AUTHORITY. Certificates which contain a provision or reservation in the cancellation clause that the issuing company will "endeavor to" mail thirty (30) days notice to the certificate holder, "but failure to

mail such notice shall impose no obligation or liability of any kind upon the company, its agents or representatives," or similar conditional notice of cancellation provisions, will not be accepted by the AUTHORITY.

(a) The kinds and amounts of insurance required are as follows: (CONSULTANT'S sub-contractors and subconsultants shall procure and maintain the same insurance as applicable.)

1. Workers' Compensation and Employers Liability Insurance: A policy or policies providing protection for Employees of the CONSULTANT or subcontractor in the event of job-related injuries as required by law.

Coverage A:	Statutory		
Coverage B:	Bodily Injury by Accident	\$1,000,000	each accident
	Bodily Injury by Disease	\$1,000,000	policy limit
	Bodily Injury by Disease	\$1,000,000	each employee

2. Automobile Liability Policies including coverage for any owned automobile(s), hired automobile(s) and non-owned automobile(s), shall be furnished with limits of not less than:

Liability For Bodily Injury & Property Damage	
Combined Single Limit	\$5,000,000

3. General Liability Insurance: Commercial General Liability (Occurrence Form) including contractual, personal injury, premises/products and completed operations liability, explosion, collapse and underground and broad form property damage and shall cover all operations and shall be furnished with limits of not less than:

Liability For Bodily Injury & Property Damage	
Combined Single Limit	\$5,000,000

The general liability insurance required must include contractual liability insurance applicable to CONSULTANT'S obligations under this Agreement. Provide a list of all endorsed exclusions, if any. CONSULTANT shall maintain products/completed operations coverage for the duration of this Agreement and for a minimum of three years after completion of all services covered by this Agreement

4. Professional Liability Insurance: CONSULTANT shall maintain a Professional Liability policy throughout the duration of this Agreement and agrees to maintain the policy for a minimum of three years after completion of all services covered by this Agreement.

Limit	\$5,000,000 Each Claim
-------	------------------------

If the policy has an annual aggregate limit, CONSULTANT shall immediately notify the AUTHORITY of any and all claims which have or may be charged against such limit.

The above specified limits may be met through either primary or excess coverage

policies, provided that any excess coverage is written on a following form basis and it is at least as broad as the underlying policies and that any deductible or retention amount does not exceed \$25,000 or 10% (in total), whichever is less, of the required liability limits. The AUTHORITY may accept policies with coverage, exclusions or liability limits different than those specified above when such policies, in the sole judgment of the AUTHORITY, will provide satisfactory protection to the AUTHORITY.

The policies specified above, except for Professional Liability, Workers' Compensation and Disability Benefits, shall be endorsed to include the **ALBANY COUNTY AIRPORT AUTHORITY AND ITS AGENT, AFCO AvPORTS MANAGEMENT, LLC, THE COUNTY OF ALBANY, THE FEDERAL AVIATION ADMINISTRATION, and THE STATE OF NEW YORK**, and any other substituted or additional agents the AUTHORITY may hire, as additional insureds, as respects services performed by the CONSULTANT and all policies shall include a provision restricting the right of the insurer to cancel or materially change such coverage except upon thirty days' written notice to AUTHORITY. Certificates evidencing the coverage of the additional insureds a copy of the policy endorsement that adds the requested entities as Additional Insureds, or that section of the General Liability policy that provides for automatic coverage for Additional Insureds when it is required under the terms of a written contract shall be delivered to AUTHORITY prior to performing any services under this Agreement.

If the Project involves on-site construction-phase services by the CONSULTANT, construction contractors shall be required to provide (or AUTHORITY may provide) Owner's Protective Liability insurance naming the **ALBANY COUNTY AIRPORT AUTHORITY, AND ITS AGENT, AFCO AvPORTS Management, LLC, THE COUNTY OF ALBANY, THE FEDERAL AVIATION ADMINISTRATION, and THE STATE OF NEW YORK** and any other substituted and additional consultants the AUTHORITY may retain as named insureds and the CONSULTANT as an additional insured on the construction contractor's liability insurance policies covering claims for personal injuries and property damage.

- (b) The policy or policies covering the obligations of the CONSULTANT, set forth in subparagraph (a)(1) above, shall be in accordance with the provisions of any applicable Workers' Compensation or Disability Benefits Law, including for the State of New York, Chapter 41, Laws of 1914, as amended, known as the Workers' Compensation Law, and amendments thereto, and Chapter 600 of the Laws of 1949, as amended, known as the Disability Benefits Law. This Agreement shall be void and of no effect unless the CONSULTANT procures such policy or policies and maintains the same in force during the term of this Agreement.
- (c) If AUTHORITY has any objection to the coverage afforded by or other provisions of the insurance required to be purchased and maintained by CONSULTANT in accordance with paragraph (a) on the basis of its not complying with this Agreement, the AUTHORITY will notify CONSULTANT in writing thereof within thirty (30) days of the date of delivery of such certificates to the AUTHORITY. CONSULTANT will provide such additional information in respect of insurance provided by CONSULTANT as the AUTHORITY may reasonably request. Failure of AUTHORITY to give any such notice of objection within the time provided shall constitute acceptance of such insurance as carried by the CONSULTANT as complying with this Agreement.

ARTICLE XIII - TERMINATION OF CONTRACT

The Parties agree that the service set forth under Article II - "Scope of Work" of this Agreement shall commence upon execution of the Agreement and will continue in effect until completed.

The Authority shall have the right at any time to terminate this Agreement without cause, provided that thirty (30) days written notice of such termination is given in advance by the party terminating the contract. In the event this Agreement is terminated, the Consultant shall be entitled to full compensation, as allowed for herein, for all work previously authorized and performed pursuant to this Agreement. This Agreement can be terminated on twenty four (24) hours written notice or termination for cause and compensation to Consultant will be on quantum merit less any backcharges or damages sustained or to be sustained by the Authority.

Suspension or Termination of Performance

- (A) Authority may at any time, and for any reason, direct Consultant to stop Consultant's services under this agreement for a period of time. This direction must be in writing and must specify the period during which the services are to be stopped. Consultant shall resume services on the date specified in the direction, or on any other date owner subsequently specifies in writing. The period during which services are stopped is deemed to be added to the time fixed for performance. Stoppage of services under this Section shall not give rise to any claim against owner.
- (B) In the event that:
 - (a) For any reason or through any cause, consultant fails to complete performance within the time fixed for performance under this agreement;
 - (b) Grounds for cancellation of the agreement under this section arise;
 - (c) Consultant otherwise defaults under this agreement;
 - (d) Authority gives consultant written notice that in its opinion, the conduct of consultant is such that the interests of owner are likely to be impaired or prejudiced, stating the facts on which the opinion is based; then authority may, on written notice to consultant, immediately terminate this agreement for cause.
- (C) Nothing in this Section is to be construed to relieve consultant from any liability and/or damages sustained by authority as a result of any breach by consultant of this agreement, and payment by authority to consultant of any monies pursuant to this section does not bar owner from any and all remedies it may otherwise have against consultant for any failure of consultant to perform its services in accordance with this agreement.
- (D) Authority is not required to pay consultant under this section until consultant has satisfactorily completed the services required to be performed to the agreed point of suspension or termination.
- (E) Payment by owner to consultant of any monies pursuant to this Section does not bar owner from any and all remedies it may otherwise have against consultant for any failure of consultant to perform its services in accordance with this agreement.
- (F) If this agreement is terminated for any reason, consultant, prior to any payment to consultant pursuant to this section, shall deliver to authority the complete set of all original drawings prepared to the date of termination. Authority is entitled to use the ideas and designs contained in this agreement for the completion of the project; in the event of termination of this agreement or upon completion of the project, authority may, at all times, retain the originals of all such drawings, originals of renderings, special art work, or models. All drawings, plans, specifications, rendering and models,

etc. are the property of authority. They are not to be used by any person other than authority on other projects unless expressly authorized by owner. Consultant is not responsible for any work that has not been completed as of the date of termination under this agreement.

ARTICLE XIV - DELIVERY OF RECORDS

In the event of the termination of this Agreement, as provided in ARTICLE XIII, hereof, all data and records pertaining to the Agreement shall be delivered within twenty (20) days to the Authority or its duly authorized representative. In case of failure of the Consultant to make such delivery on demand, then and in that event, the Consultant shall be liable to the Authority for any damages it may sustain by reason thereof.

ARTICLE XV - DISSOLUTION

In the event of dissolution of the Consultant during the existence of this Agreement, the Consultant shall give thirty (30) days' notice in writing to the Authority in advance of such dissolution.

ARTICLE XVI - LICENSES

The Consultant shall at all times obtain and maintain all licenses required by New York State to perform the services required under this Agreement.

ARTICLE XVII - NON-DISCRIMINATION REQUIREMENT

In accordance with Article 15 of the Executive Law (also known as the Human Rights Law) and all other State and Federal Statutory and constitutional non-discrimination provisions, the Consultant agrees that it shall not, by reason of race, creed, color, national origin, age, sex or disability: (a) discriminate in hiring against any person who is qualified and available to perform the work; or (b) discriminate against or intimidate any employee hired for the performance of work under this Agreement.

ARTICLE XVIII - NON-APPROPRIATIONS CLAUSE

Notwithstanding anything contained herein to the contrary, no default shall be deemed to occur in the event no funds or insufficient funds are appropriated and budgeted by or are otherwise unavailable to the Authority for payment, the Authority will immediately notify the Consultant of such occurrence and this Agreement shall terminate on the last day of the fiscal period for which appropriations were received without penalty or expense to the Authority of any kind whatsoever, except as to those portions herein agreed upon for which funds shall have been appropriated and budgeted.

ARTICLE XIX - APPLICABLE LAW

This Agreement shall be construed for all purposes under the laws of the State of New York. Any litigation pursuant to this Agreement shall be in the Supreme Court of the State of New York in the County of Albany.

ARTICLE XX – MANDATORY FEDERAL CONTRACT PROVISIONS

Federal laws and regulations prescribe that certain provisions be included in certain contracts. The provisions set forth in Appendix B are attached hereto and made a part hereof.

ARTICLE XXI - NOTICE

All notices and documents required to be given or made by the Consultant pursuant to this Agreement shall be given or made to:

Albany County Airport Authority
Chief Executive Officer
Albany International Airport
737 Albany Shaker Road
Main Terminal, 3rd Floor
Albany, NY 12211

All notices and documents to be given or made by the Authority pursuant to this Agreement shall be given or made to:

Fennick McCredie Architecture, LTD
70 Franklin Street
Boston, MA 02110

ARTICLE XXII - INVALID PROVISIONS

It is further expressly understood and agreed by and between the parties hereto that in the event any covenant, condition or provision herein contained is held to be invalid by any court or competent jurisdiction, the invalidity of such covenant, condition or provision shall in no way affect any other covenant, condition or provision herein contained; provided, however, that the invalidity of any such covenant, condition or provision does not materially prejudice either Authority or Consultant in their respective rights and obligations contained in the valid covenants, conditions or provisions in this Agreement.

IN WITNESS WHEREOF, this Agreement has been executed by the Authority, acting by and through the Chairman of the Authority, and the Consultant, by and through a duly authorized officer has executed this Agreement effective the day and year first above written. The Authority and Consultant agree to delivery by facsimile or by electronic transmission in portable document format (PDF) of an executed original of this Agreement is as effective as delivery of an originally executed Agreement.

ALBANY COUNTY AIRPORT AUTHORITY

BY:



Samuel A. Fresina

Chairman

Or

Philip F. Calderone, Esq.

Chief Executive Officer

FENNICK McCREDIE ARCHITECTURE, LTD

BY:

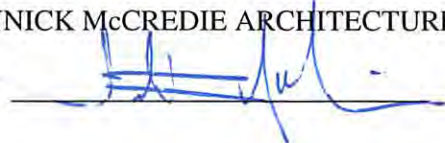

STATE OF NEW YORK)
) ss.:
COUNTY OF ALBANY)

On the _____ day of _____, 20____, before me personally appeared Samuel A. Fresina, to me known, to be the person who executed the above instrument, who, being duly sworn, did depose and say that he resides in the County of Albany, that he is the Chairman of the Albany County Airport Authority, the public benefit corporation described in, and which executed the foregoing instrument in the name of the Albany County Airport Authority pursuant to a resolution adopted by the Albany County Airport Authority on December 5, 2022; and that he signed his name thereto by like authorization.

Notary Public

STATE OF NEW YORK)
) ss.:
COUNTY OF ALBANY)

On the 13th day of January, 2023, before me personally appeared Philip F. Calderone, Esq., to me known, to be the person who executed the above instrument, who, being duly sworn, did depose and say that he resides in the County of Albany, that he is the Chief Executive Officer of the Albany County Airport Authority, the public benefit corporation described in, and which executed the foregoing instrument in the name of the Albany County Airport Authority pursuant to a resolution adopted by the Albany County Airport Authority on December 5, 2022; and that he signed his name thereto by like authorization.

Jennifer A. Munger
Notary Public

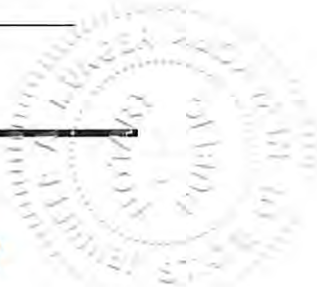

STATE OF _____)
) ss.:
COUNTY OF _____)

JENNIFER A. MUNGER
Notary Public, State of New York
No. 01MU6246332
Qualified in Schenectady County
Commission Expires Aug. 08, 2023

On this ____ day of _____, 20__ before me personally came _____, to me known, who being by me duly sworn, did depose and say that he/she resides in _____ County, that he/she is the _____ of _____, the LLC described in, and which executed the within instrument; and that he/she signed his/her name thereto by order of the LLC.

Notary Public

STATE OF Massachusetts)
) ss.:
COUNTY OF Suffolk)

On this 12th day of January, 2023, before me personally came Jonathan McCredie, to me known, who being by me duly sworn, did depose and say that he/she resides in Suffolk County, that he/she is the Treasurer of Fennick McCredie Architecture, Ltd., the corporation described in, and which executed the within instrument; that he/she knows the seal of said corporation; that the seal affixed to said instrument is such corporate seal; that it was affixed by order to the Board of Directors of said corporation; and that he/she signed his/her name thereto by like order.

Patricia A. Brinson

Notary Public



STATE)
) ss.:
COUNTY OF)

On this _____ day of _____, 20____, before me personally came _____, to me known, who, being duly sworn, did depose and say that he resides in _____ County, that he is a _____ of _____ the partnership described in, and which executed the within instrument.

Notary Public

SCHEDULE "A"

SCOPE OF WORK

The Albany County Airport Authority has requested statements of qualifications from firms for the Rehabilitation of Concourse A including the addition of two new jet bridges. The design will focus on Concourse A to add passenger seating capacity while maintaining passenger flow. The Project will also include site work and design for two new jet bridges and additional concrete pavement for aircraft parking, aircraft parking/positioning as well as the bridge design, layout and connection of the Boarding Bridge to Concourse A.

Prepare the Engineers Estimate of Probable Cost in advance of the public bid opening and Comparative Table of Construction bids received with Engineers Recommendation for Award;

1. Evaluate and approve shop drawing submittals and respond to contractor Request for Information; prepare weekly Construction Progress Inspection Reports during active work periods for submittal on a monthly basis with select digital color representative progress photos. All deliverable documents must be in the formats specified by the Airport Authority.
2. The Consultant will participate in a Project Kick-off Meeting held at the airport, and prepare a summary of the meeting and distribute the summary to all attendees.
3. The Consultant will submit a full copy of digital as-built record drawings to the Airport at the completion of the project.

The engineering project scope and schedule will include:

- **Programming and Project Review**
- **Existing Conditions Recordation**
- **Bid Document Review**
- **Estimates and Schedules**

Tentative Schedule: **Approval - two (2) weeks**

The Authority, where applicable, will make available all existing record data, drawings of original construction, contractual or legal agreements and subsequent modifications as may be applicable to the project.

SCHEDULE "B"

FEE SCHEDULE
(with Claim Form, attached)

Project: **Albany International Airport -**
 Owner: Albany County Airport Authority
 Prime: FM
 Proj #: 1236
 Date: 11/9/2022

FEE SUMMARY

		Labor								
		Phase Total	FM	MJ: Aviation	MJ: Structural	MJ: MEP-FP	VDA - Vertical Transportation Consultant	Ellana: Cost Est.	CRC: Code	Kalin: Specs
PART 1: DESIGN SERVICES	Project Administration & Management	\$92,209	\$56,148	\$35,022	\$742	\$297	\$0	\$0	\$0	\$0
	Project Definition	\$122,760	\$50,600	\$28,492	\$19,885	\$7,865	\$2,920	\$7,068	\$5,931	\$0
	30% Design - Schematic Design	\$169,645	\$70,630	\$38,286	\$28,195	\$11,575	\$2,190	\$11,441	\$6,328	\$1,000
	60% Design - Design Development	\$209,693	\$93,892	\$37,990	\$28,937	\$19,143	\$5,888	\$13,845	\$4,998	\$5,000
	100% Design - Construction Documents	\$226,180	\$141,419	\$23,743	\$16,917	\$11,575	\$3,650	\$18,908	\$5,969	\$4,000
	Bidding	\$30,046	\$17,992	\$5,342	\$2,968	\$2,968	\$0	\$0	\$775	\$0
	Part 1 Total	\$850,533	\$430,681	\$168,875	\$97,644	\$53,423	\$14,648	\$51,262	\$24,001	\$10,000
	% of \$12m construction cost	7.09%								
PART 2	Construction Administration	\$259,872	\$172,217	\$30,190	\$23,697	\$16,880	\$15,330	\$0	\$1,558	\$0
		% of \$12m construction cost	2.17%							
	Part 1 & 2 Fee Total	\$1,110,406	\$602,898	\$199,065	\$121,341	\$70,303	\$29,978	\$51,262	\$25,559	\$10,000
	% of \$12m construction cost	9.25%	54.30%	17.93%	10.93%	6.33%	2.70%	4.62%	2.30%	0.90%
\$507,507										
		Expenses								
		Phase Total	FM	MJ: Aviation	MJ: Structural	MJ: MEP-FP	VDA - Vertical Transportation Consultant	Ellana: Cost Est.	CRC: Code	Kalin: Specs
PART 3	Expenses (Sub Consultant + Direct Exp.)									
	See Back Up Exhibits	\$84,957	\$11,038	\$72,919	\$0	\$0	\$500	\$0	\$500	\$0
	Totals	\$84,957	\$11,038	\$72,919	\$0	\$0	\$500	\$0	\$500	\$0
		Totals- Labor + Expenses								
		Phase Total	FM	MJ: Aviation	MJ: Structural	MJ: MEP-FP	VDA - Vertical Transportation Consultant	Ellana: Cost Est.	CRC: Code	Kalin: Specs
PART 1	Project Administration & Management	\$92,209	\$56,148	\$35,022	\$742	\$297	\$0	\$0	\$0	\$0
	Project Definition	\$122,760	\$50,600	\$28,492	\$19,885	\$7,865	\$2,920	\$7,068	\$5,931	\$0
	30% Design - Schematic Design	\$169,645	\$70,630	\$38,286	\$28,195	\$11,575	\$2,190	\$11,441	\$6,328	\$1,000
	60% Design - Design Development	\$209,693	\$93,892	\$37,990	\$28,937	\$19,143	\$5,888	\$13,845	\$4,998	\$5,000
	100% Design - Construction Documents	\$226,180	\$141,419	\$23,743	\$16,917	\$11,575	\$3,650	\$18,908	\$5,969	\$4,000
	Bidding	\$30,046	\$17,992	\$5,342	\$2,968	\$2,968	\$0	\$0	\$775	\$0
	Part 1 Total	\$850,533	\$430,681	\$168,875	\$97,644	\$53,423	\$14,648	\$51,262	\$24,001	\$10,000
PART 2	Construction Administration	\$259,872	\$172,217	\$30,190	\$23,697	\$16,880	\$15,330	\$0	\$1,558	\$0
	Part 1 & 2 Fee Total	\$1,110,406	\$602,898	\$199,065	\$121,341	\$70,303	\$29,978	\$51,262	\$26,059	\$10,000
PART 3	Expenses (Sub Consultant + Direct Exp.)	\$84,957	\$11,038	\$72,919	\$0	\$0	\$500	\$0	\$500	\$0
	Totals	\$1,195,363	\$613,936	\$271,984	\$121,341	\$70,303	\$30,478	\$51,262	\$26,059	\$10,000
	% of \$12m construction cost	9.96%	51.36%	22.75%	10.15%	5.88%	2.55%	4.29%	2.18%	0.84%

Notes: Refer to Back Up Worksheets for Hourly Breakout for FM, VDA, Ellana, CRC.
 Fee Breakout and Assumptions for MJ attached as separate document

**Albany International Airport -
LABOR BREAKDOWN**

FM

Date: 11/21/2022

50

Scope	Start week	End week	Labor Dollars		Labor Hours							
			Labor subtotal (Loaded)	Sub Task Totals (Unloaded)	PIC	PH	PA	SA	PD	PD	QA/QC	
Multiplier:		2.5			Jonathan McCredie	Melissa Vaillancourt	David Potter	TBD Staff Architect	TBD Project Designer	TBD Project Designer		Gary Coccoluto
Unloaded Billing Rates					91.88	50.34	45.37	50	35	35		65.85
PART 1: DESIGN SERVICES 42 weeks												
Project Administration & Management 42 weeks												
1.00 Project Management			\$41,263									
1.01 Contract Administration			\$6,058		10	30						
1.02 Schedule Development and Management			\$4,262			34						
1.03 Owner/Design Team Checks Ins			\$22,632		32	64	64					
1.04 Conduct/attend design coordination meetings prior to each submission			\$6,055		8	8	16			16		
1.05 Prepare Monthly Project Status/Progress reports			\$2,256			18						
2.00 Funding and Grants			\$14,885									
2.01 Assist in preparation of content, including Narrative and Graphics for BIL Application			\$11,877		20	40	20					
2.02 Ongoing Coordination re: PFC and other eligible vs ineligible scopes			\$3,008			24						
			\$0									
Project Administration & Management Hours				404 hrs	70	218	100	0	16	0	0	0
Project Administration & Management Totals			\$56,148		\$16,079	\$27,326	\$11,343	\$0	\$1,400	\$0	\$0	\$0
Project Definition 6 weeks												
1.00 Existing Conditions			\$17,933									
1.01 Review of Existing Conditions Documents and Information Provided by ACAA			\$5,727		8	8	24					
1.02 Existing facility due diligence			\$7,377		8	8	40					
1.03 Laser Scanning (coordination/implementation)			\$1,329				4			10		
1.04 Building Modeling			\$3,500							40		
			\$0									
2.00 Programming			\$8,783									
2.01 Program Confirmation			\$4,426		4	8	16			8		
2.02 Design Narrative & Program Summary Memo			\$1,367		2		8					
2.03 Concept Phasing/Feasibility Diagrams			\$2,980		4		12			8		
			\$0									
3.00 Regulatory Analysis			\$1,958									
3.01 Provide Outline, schedule and Narratives of all relevant FAA AHJ and Environmental Permitting			\$1,003			8						
3.02 Prepare Outline Code Report and Existing Conditions Overview			\$955			4	4					
			\$0									
4.00 Sustainability			\$9,685									
4.01 Confirmation of Sustainable Goals			\$4,842		4	4	24			8		
4.02 Feasibility Overview of LEED Certification			\$4,842		4	4	24			8		
5.00 Preliminary Design			\$12,241									
5.01 Conceptual Design			\$9,167		8	20	24			24		
5.02 Cost Estimate			\$2,370		2	8	8					
5.03 Code Impact			\$704			2	4					
5.05 Preliminary CSPP			\$0									
			\$0									
Project Definition Hours				417 hrs	44	74	192	0	106	0	0	0
Project Definition Totals			\$50,600		\$10,107	\$9,276	\$21,778	\$0	\$9,275	\$0	\$165	\$0
30% Design - Schematic Design 8 weeks												
1.00 Architectural Documentation & Design			\$41,947									
1.01 Design Concept Development			\$14,693		8	16	54			54		
1.02 Architectural Demolition			\$1,754		2	4	4			12		
1.03 Finishes/Furniture			\$1,054			2	4			4		
1.04 Envelope			\$828			2	2			4		
1.05 Planning, bubble diagrams			\$2,280		4		12					

**Albany International Airport -
LABOR BREAKDOWN**

FM

Date: 11/21/2022

Scope		Labor Dollars		Labor Hours							
Start week	End week	Labor subtotal (loaded)	Sub Task Totals (loaded)	PIC	PM	PA	SA	PD	PD	QAOC	
				Jonathan McCredie	Melissa Vaillancourt	David Penner	TBD Staff Architect	TBD Project Designer	TBD Project Designer	Gary Carcolata	
Multiplier: 2.5				91.83	50.14	45.37	50	35	35	65.85	
Unloaded Billing Rates											
1.05	Wayfinding/Signage		\$804				4		4		
1.07	Graphics/Renderings		\$4,937		4		20		20		
1.08	Coordination		\$7,360		8	12	20		20		
1.09	Material research		\$2,061				12		8		
1.10	Outline Specifications		\$3,112			12	8		8		
1.11	Phasing/Constructability		\$3,064			8	12		8		
2.00	Cost Estimating	\$3,330									
2.01	Statement of probable cost		\$1,415		2	4	4				
2.02	Value Management, Cost Review		\$1,916		2	8	4				
3.00	Sustainability	\$13,591									
3.01	Life Cycle Assessment		\$2,915			4	12		12		
3.02	LEED Certification Pursuit		\$4,671			8	20		16		
3.03	Resiliency		\$6,009		8	4	20		16		
4.00	Quality assurance and Quality Control	\$11,033									
4.01	Design team QAOC		\$11,033		8	8	8		8	40	
5.00	Regulatory	\$728									
5.01	Updated Code Report, Draft Life Safety Plans		\$728			4	2				
30% Design - Schematic Design Hours			594 hrs	94	94	222	0	194	0	40	
30% Design - Schematic Design Totals			\$70,630	\$10,107	\$11,783	\$25,180	\$0	\$16,975	\$0	\$6,585	
60% Design - Design Development		10 weeks									
1.00	Architectural Documentation & Design	\$63,104									
1.01	Architectural Design		\$25,739		16	24	60		160		
1.02	Architectural Demolition		\$4,861				12		40		
1.03	Finishes/Furniture		\$2,722				24				
1.04	Envelope		\$1,154				4		8		
1.05	Planning, bubble diagrams		\$0								
1.06	Wayfinding/Signage		\$2,269				20				
1.07	Graphics/Renderings		\$5,791		4		24		36		
1.08	Coordination		\$10,178		8	20	36		20		
1.09	Material Research, Detailing		\$3,215				16		16		
1.10	3 Part Specifications		\$3,112			12	8		8		
1.11	Phasing plans, CSPP		\$3,064			8	12		8		
2.00	Cost Estimating	\$3,330									
2.01	Statement of probable cost		\$1,415		2	4	4				
2.02	Value Management, Cost Review		\$1,916		2	8	4				
3.00	Sustainability	\$15,812									
3.01	Life Cycle Assessment		\$2,915			4	12		12		
3.02	LEED		\$5,531			4	32		16		
3.03	Resiliency		\$7,369		8	4	32		16		
4.00	Quality assurance and Quality Control	\$9,963									
4.01	Design team QAOC		\$9,963		4	4	8		12	40	
5.00	Regulatory	\$1,683									
5.01	Updated Code Report, Updated Life Safety Plans		\$728			4	2				
5.02	Prep and Attend Information Meeting with AHJ (Virtual)		\$955			4	4				
			\$0								
60% Design - Design Development Hours			830 hrs	44	100	314	0	332	0	40	
60% Design - Design Development Totals			\$93,892	\$10,107	\$12,533	\$35,619	\$0	\$29,050	\$0	\$6,585	
100% Design - Construction Documents		14 weeks									
1.00	Architectural Documentation & Design	\$102,549									

**Albany International Airport -
LABOR BREAKDOWN**

FM
Date: 11/21/2022

\$0

Scope		Labor Dollars		Labor Hours							
Multiplier:	Start week	End week	Labor subtotal (located)	Sub Task Totals (located)	PIC	PM	PA	SA	PD	PD	QAQC
					Jonathan McCredie	Melissa Vaillancourt	David Potter	TBD Staff Architect	TBD Project Designer	TBD Project Designer	Gary Coccoluto
Unloaded Billing Rates					91.88	50.14	45.37	50	35	35	65.85
1.01	Architectural Design			\$41,452	16	24	20	120	200		
1.02	Architectural Demolition			\$6,384			10		60		
1.03	Finishes			\$4,822			24		24		
1.04	Envelope			\$907			8				
1.05	Planning, bubble diagrams			\$0							
1.06	Wayfinding/Signage			\$2,269			20				
1.07	Graphics/Renderings			\$11,166	4		24		86		
1.08	Coordination			\$13,678	8	20	36		60		
1.09	Material Research, Detailing			\$3,215			16		16		
1.10	3 Part Specifications			\$3,637		12	8		14		
1.11	Phasing plans, CSPP			\$3,764		8	12		16		
1.12	90% Progress Stop and Plot, interim Coordination			\$11,255	4	8	36		60		
				\$0							
2.00 Cost Estimating			\$11,901								
2.01	90% Progress Cost Estimate (Design Team Stop and Plot)			\$5,851	6	12	20		8		
2.02	Value Management, Cost Review			\$955		4	4				
2.03	100% Cost Review/Update			\$4,140	6	12	8		4		
2.04	Value Management, Cost Review			\$955		4	4				
				\$0							
3.00 Sustainability			\$19,079								
3.01	Life Cycle Assessment			\$2,913		4	12		12		
3.02	LEED			\$7,541		10	40		20		
3.03	Resiliency			\$8,626	8	4	40		20		
				\$0							
4.00 Quality assurance and Quality Control			\$6,585								
4.01	Design team QAQC			\$6,585							40
				\$0							
5.00 Regulatory			\$1,305								
5.01	Updated Code Report, Updated Life Safety Plans			\$1,305		4	4		4		
				\$0							
100% Design - Construction Documents Hours				1,298 hrs	57	126	340	710	608	0	40
100% Design - Construction Documents Totals				\$14,149	\$1,944	\$15,394	\$39,243	\$18,000	\$92,850	\$0	\$0,360
Bidding		6 weeks									
1.00 Bidding			\$17,992								
1.01	Compile Bid Documents, Assist in Advertising Narrative etc.			\$2,364		8	12				
1.02	Attend Pre-bid walk-through			\$1,910		8	8				
1.03	Respond to and track RFI			\$5,112		2	12		40		
1.04	Perform Bid analysis			\$5,145	4	12	24				
1.05	Conformed drawings			\$3,461			12		24		
				\$0							
Bidding Hours				166 hrs	4	30	68	0	64	0	0
Bidding Totals				\$17,992	\$919	\$3,761	\$7,713	\$0	\$5,600	\$0	\$0
PART 2: CONSTRUCTION SERVICES		60 weeks									
Construction Administration		34 months									
1.00 Submittals			\$52,208								
1.01	Submittal log			\$24,403			30		240		
1.02	Submittal review			\$27,806			60		240		
				\$0							
2.00 Sustainability			\$8,037								
2.01	LEED			\$8,037			40		40		
				\$0							
3.00 Request for Information (RFI)			\$28,000								
3.01	RFI review			\$5,250					60		
3.02	Supplemental Information			\$22,750					260		
				\$0							
4.00 Field Observation			\$3,176								
4.01	Field observation (assume 1 visit ev 2 mo, supplemented by MJ)			\$3,176			28				
				\$0							

**Albany International Airport -
LABOR BREAKDOWN**

FM
Date: 11/21/2022

50

Scope		Labor Dollars		Labor Hours						
Start week	End week	Labor subtotal (loaded)	Sub Task Totals (loaded)	PIC	PM	PA	SA	PD	PD	OAGC
Multipliers:	2.5			Jonathan McCredie	Melissa Vaillancourt	David Porter	TBD Staff Architect	TBD Project Designer	TBD Project Designer	Gary Coccolone
Unloaded Billing Rates				91.88	50.14	45.37	50	35	35	65.85
5.00 Construction Changes		\$28,088								
5.01	Cost log		\$5,769				20		40	
5.02 Proposed Change Orders (PCO)		\$11,160								
5.03	Construction Change Directives		\$11,160		20	30		60		
6.00 Construction meetings		\$41,500								
6.01	OAC meetings (assume weekly)		\$29,828	15	60	120		60		
6.02	Owner meetings (assume monthly * 2 mo for closeout/precon)		\$11,673	8	16	32		48		
7.00 Contractor pay requisition		\$1,588								
7.01	Pay Req. review		\$1,588			14				
8.00 Project Close out		\$9,620								
8.01	Punch Lists		\$2,411				12		12	
8.02	Operation and Maintenance manuals		\$1,050						12	
8.03	Warranties		\$700						8	
8.04	Substantial completion		\$1,910		8	8				
8.05	Final construction affidavits		\$919	4						
8.06	Record drawings		\$2,176	4		8			4	
8.07	Final completion		\$454			4				
Construction Administration Hours			1,731 hrs	20	124	416	20	134	20	0
Construction Administration Totals			672,227	27.81	131.54	449.63	50	309.20	36	50



EXHIBIT B
Rehabilitation of Concourse A
S-22-1127

Albany County Airport Authority
Albany International Airport

Draft
November

FEE SUMMARY

	DESIGN / PLANNING SERVICES	CONSTRUCTION SERVICES
1. DIRECT TECHNICAL LABOR	\$101,167.70	\$22,377.18
2. ESTIMATED OVERHEAD EXPENSES AND PAYROLL BURDEN Based on Percentage of Direct Salary Cost (exclusive of Premium Pay) with the estimated Percentage being 175.00 %	\$177,043.48	\$39,160.07
3. SUBTOTAL OF ITEMS 1 & 2	\$278,211.18	\$61,537.25
4. FIXED FEE / PROFIT	\$41,731.68	\$9,230.59
5. DIRECT EXPENSES	\$1,854.00	\$4,695.00
6. SUBCONSULTANT COSTS	\$22,370.00	
SY Kim Land Surveyor, PC (Survey)	\$22,370	
7. SUBCONTRACT COSTS - (ESTIMATE)	\$44,000.00	
John P. Stopen Engineering, LLP (Geotech)	\$44,000	
8. OVERTIME PREMIUM		
9. TOTAL FEE ESTIMATE	\$388,166.86	\$75,462.84
10. TOTAL FEE FOR ALL SERVICES		

\$463,630

NOTE: Authorized hours worked in excess of forty per week are subject to a premium time charge



Rehabilitation of Concourse A				
S-22-1127				
Albany County Airport Authority				
Albany International Airport				
Draft				
November				
McFARLAND-JOHNSON LABOR RATES				
DIRECT TECHNICAL LABOR				
		CURRENT	PROJECT	2022
		AVG. RATE	AVG. RATE	MAX. RATE
CLASSIFICATION				
Vice President (VP)		\$93.74	\$97.11	\$93.74
Division Director/Reg.Div.Director (DD)		\$81.78	\$84.72	\$96.26
Senior Project Manager (SPM)		\$76.92	\$79.69	\$83.00
Sr. Project Engineer (SPE)		\$59.90	\$62.06	\$65.00
Project Engineer (PE)		\$53.17	\$55.08	\$61.14
Senior Engineer (SE)		\$44.20	\$45.79	\$51.20
Assistant Engineer (AE)		\$36.12	\$37.42	\$41.80
Junior Engineer/Planner/Envrmtlst (JEP1)		\$29.91	\$30.99	\$35.44
Junior Engineer/Planner/Envrmtlst (JEP2)		\$31.67	\$32.81	\$34.66
Technician Supervisor (TS)		\$47.98	\$49.71	\$49.40
Senior Technician (ST)		\$36.82	\$38.15	\$40.04
Assistant Technician (AT)		\$23.69	\$24.54	\$29.00
Junior Technician (JT)		\$18.50	\$19.17	\$18.50
Resident Inspector (RI)		\$51.03	\$52.87	\$52.32
Senior Inspector (SI)		\$41.65	\$43.15	\$47.62
Inspector (I)		\$40.04	\$41.48	\$40.04
	Assume Notice to Proceed:	12/15/2022		
	Design Project Duration (months):	13		
	Assume Salary Escalation:	4.0%		
Year	Compounded Escalation Factor	% Work in year	Effective %	
2022	1.000	10.0%	10.0%	
2023	1.040	90.0%	93.6%	
2024	1.082	100.0%	103.6%	



Rehabilitation of Concourse A

S-22-1127

**Albany County Airport Authority
Albany International Airport**

**Draft
November**

DIRECT COSTS

	DESIGN / PLANNING SERVICES	CONSTRUCTION SERVICES
Travel Related Costs:		
Vehicle Cost Plus Fuel	\$1,044	\$2,386
Lodging and Meals	\$660	\$2,259
Per Diem		
Reproduction		
CADD Plots		
Prints		
Photocopies		
Photo Costs		
Telephone/Fax:		
Postage/Delivery	\$100	
Miscellaneous	\$50	\$50
	\$1,854	\$4,695

\$6,549

ESTIMATED HOURS

PHASE/TASK	DESCRIPTION	VP	DD	SJM	SPE	PE	SE	AE	JEP1	JEP2	TS	ST	AT	JT	RI	SI	SUM
1.1	Scope and Fee																243
1.2	PM dates																29
1.3	Monthly Status Reports																48
1.4	Schedule Coordination																105
2.1	Project Definition																379
2.2	Design Kickoff Meeting																14
2.3	Existing Data Review																66
2.4	Preliminary Site Visit																14
2.5	Survey Coordination / Base Mapping																30
2.6	Geotech Coordination																28
2.7	Pavement Layout																26
2.8	OA/C																27
2.9	Conceptual Design Submission																64
2.9	Conceptual Design Review Meeting																28
2.10	Tenant Review Meeting																8
2.11	Conceptual Design CFP																211
2.12	Feasibility Analysis																212
3.1	Preliminary Design Plans																529
3.2	3D Architectural Design																212
3.3	Existing Structural Analysis																44
3.4	Existing Structural Analysis																20
3.5	Preliminary Structural Analysis																44
3.6	Preliminary Estimates																20
3.7	MEPFP Field Investigations																33
3.8	MEPFP Constructability Review																9
3.9	MEPFP Existing Systems BIM Modeling																3
3.10	MEPFP Demo																3
3.11	MEP System Descriptions																3
3.12	NYS Fire Code Review																3
3.13	Plumbing Fixture Counts																3
3.14	Electrical and Special Systems Concepts																15
3.16	Preliminary Design Report																8
3.16	System Schematics																35
3.17	OA/C																32
3.18	Preliminary Design Review Meeting																28
3.19	Preliminary Design Submission																25
60% Design - Design Development																	550
4.1	Architectural Final Design																100
4.2	Engineer's Design Report																40
4.3	Final Design Plans																128
4.4	Incorporate 30% Comments																15
4.5	Mechanical Design																13
4.6	Medical Design																20
4.7	Plumbing Design																7
4.8	MEPFP Details and Schematics																34
4.10	Specifications																9
4.11	Final Design Estimate																36
4.12	740 (s)																28
4.13	OA/C																22
4.14	Final Design Plans, Specs, Estimate																48
100% Construction Documents																	352
5.1	Bid Documents																26
5.2	Bid Specifications																100
5.3	Bid Specifications																36
5.4	Bid Quantities																28
5.5	Final BIM Models																62
5.6	Bid Drawings																33
5.7	Bid Specifications																27

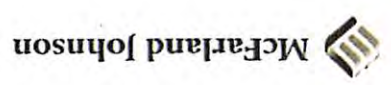

Rehabilitation of Concourse A
 S-22-1127
 Albany County Airport Authority
 Albany International Airport
 Draft
 November



ESTIMATED HOURS

PHASE/TASK DESCRIPTION	HOURS BY CLASSIFICATION														SUM		
	VP	DD	SPM	SPE	PE	SE	AE	JEP1	JEP2	TS	ST	AT	JT	RI		SI	I
	\$97.11	\$84.72	\$78.69	\$82.06	\$55.08	\$45.79	\$37.42	\$30.99	\$32.81	\$49.71	\$38.15	\$24.54	\$19.17	\$52.87	\$43.15	\$41.48	
5.8 Comment Response				4	2	14	12	8									40
Bidding and Award Assistance			4	12	8	36	8	8									76
6.1 Pre-Bid Meeting			4	8	8	8											20
6.2 RFI Response(s)				4	8	28	8	8									56
Total Hours - Design Services			132	374	80	700	528	342									2156
Total Labor Cost - Design Services			10519.1	23210.4	4406.4	32053	19757.8	11221									101168
Construction Administration			18	142	34	148	86	8									436
7.1 Pre-Construction Meeting			4	4	4												12
7.2 Reconciled Contract Documents				2	6	36	30	8									82
7.3 Site Visits			8	80	8	32											128
7.4 Shop Drawings			4	8	12	60	56										140
7.5 Project Management			2	40	8	16											40
7.6 Final Walk Through				8	8	16											34
Total Hours - Design Services			18	142	34	148	86	8									436
Total Labor Cost - Design Services			1434.42	8812.52	1872.72	6776.92	3218.12	262.5									22377.2

Albany International Airport - Terminal A Renovations

LABOR BREAKDOWN

VDA - Vertical Transportation Consultant

Date: 11.17.2022

Scope	Labor Dollars		Labor Hours					
	Labor subtotal (loaded)	Sub-Task Totals (loaded)	PIC	PM	CAD			
Multiplier: 2.5 Unloaded Billing Rates				Shawn Levins 73	Ryan McLaughlin 46			
PART 1: DESIGN SERVICES 42 weeks								
Project Administration & Management								
Project Definition (6 weeks)								
1.00 Existing Conditions	\$0							
2.00 Programming	\$0							
3.00 Regulatory Analysis	\$0							
4.00 Sustainability	\$0							
5.00 Preliminary Design	\$2,920							
5.01 Conceptual Design-Recommendation for Type/BOD		\$2,920		16				
5.02 Cost / ROM for BOD		\$0						
		\$0						
		\$0						
Project Definition Hours		16 hrs	0	16	0	0	0	0
Project Definition Totals	\$2,920		\$0	\$2,920	\$0	\$0	\$0	\$0
30% Design - Schematic Design (8 weeks)								
1.00 Architectural Documentation & Design	\$2,190							
1.01 Design Plans/Details/Documentation Freight Elevator		\$0						
1.02 Demolition Plans/Details		\$0						
1.03 Finishes		\$0						
1.04 Envelope		\$0						
1.05 Planning, bubble diagrams		\$0						
1.05 Wayfinding/Signage		\$0						
1.07 Graphics/Renderings		\$0						
1.08 Coordination		\$0						
1.09 Material research		\$0						
1.10 Outline Specifications Freight Elevator		\$2,190		12				
1.11 Phasing/Constructability		\$0						
2.00 Cost Estimating	\$0							
3.00 Sustainability	\$0							
4.00 Quality assurance and Quality Control	\$0							
5.00 Regulatory	\$0							
		\$0						
30% Design - Schematic Design Hours		12 hrs	0	12	0	0	0	0
30% Design - Schematic Design Totals	\$2,190		\$0	\$2,190	\$0	\$0	\$0	\$0
60% Design - Design Development (10 weeks)								
1.00 Architectural Documentation & Design	\$5,159							
1.01 Design Plans/Details/Documentation		\$0						
1.02 Demolition Plans/Details		\$0						
1.03 Finishes		\$0						
1.04 Envelope		\$0						
1.05 Planning, bubble diagrams		\$0						
1.06 Wayfinding/Signage		\$0						
1.07 Graphics/Renderings		\$0						
1.08 Coordination		\$778		3	2			
1.09 Material Research, Detailing		\$0						
1.10 3 Part Specifications		\$4,380		24				
1.11 Phasing plans, CSPP		\$0						
2.00 Cost Estimating	\$0							
3.00 Sustainability	\$0							
4.00 Quality assurance and Quality Control	\$730							
4.01 Design team OACC		\$730		4				
5.00 Regulatory	\$0							
		\$0						
60% Design - Design Development Hours		33 hrs	0	31	2	0	0	0
60% Design - Design Development Totals	\$5,889		\$0	\$5,658	\$230	\$0	\$0	\$0
100% Design - Construction Documents (4 weeks)								
1.00 Architectural Documentation & Design	\$2,920							
1.01 Design Plans/Details/Documentation		\$0						
1.02 Demolition Plans/Details		\$0						
1.03 Finishes		\$0						
1.04 Envelope		\$0						

1.05	Planning bubble diagrams		\$0							
1.06	Wayfinding/Signage		\$0							
1.07	Graphics/Renderings		\$0							
1.08	Coordination		\$0							
1.09	Material Research, Detailing		\$0							
1.10	3 Part Specifications		\$2,920		16					
1.11	Phasing plans, CSPP		\$0							
1.12	90% Progress Stop and Plot, interim Coordination		\$0							
2.00	Cost Estimating		\$0							
3.00	Sustainability		\$0							
4.00	Quality assurance and Quality Control		\$750							
4.01	Design team QA/QC		\$750		4					
5.00	Regulatory		\$0							
100% Design - Construction Documents Hours				20 hrs	0	20	0	0	0	0
100% Design - Construction Documents Totals			\$3,650	\$0	\$3,650	\$0	\$0	\$0	\$0	\$0

Bidding (4 weeks)										
1.00	Bidding		\$0							
1.01	Compile Bid Documents, Assist in Advertising Narrative etc.		\$0							
1.02	Attend Pre-bid walk-through		\$0							
1.03	Respond to and track RFI		\$0							
1.04	Perform Bid analysis		\$0							
1.05	Confirmed drawings		\$0							
2.00	Consultant Specific Scope		\$0							
2.01	Trade Specific (provide description if applicable)		\$0							
Bidding Hours				0 hrs	0	0	0	0	0	0
Bidding Totals			\$0	\$0	\$0	\$0	\$0	\$0	\$0	\$0

PART 2: CONSTRUCTION SERVICES (60 weeks)										
Construction Administration (6 months)										
1.00	Submittals		\$4,745							
1.01	Submittal log		\$365		2					
1.02	Submittal review		\$4,380		24					
2.00	Sustainability		\$0							
2.01	LEED		\$0							
3.00	Request for Information (RFI)		\$1,825							
3.01	RFI review		\$1,460		8					
3.02	Supplemental Information		\$365		2					
4.00	Field Observation		\$4,380							
4.01	Field observation (2) Progress Visits		\$4,380		24					
4.02	Special Inspections		\$0							
5.00	Construction Changes		\$0							
6.00	Construction meetings		\$0							
7.00	Contractor pay requisition		\$0							
8.00	Project Close out		\$4,380							
8.01	Punch Lists (1) Punch List Visit		\$4,380		24					
8.02	Building Commissioning		\$0							
8.03	Operation and Maintenance manuals		\$0							
8.04	Warranties		\$0							
8.05	Substantial completion		\$0							
8.06	Final construction affidavits		\$0							
8.07	Record drawings		\$0							
8.08	Final completion		\$0							
Construction Administration Hours				84 hrs	0	84	0	0	0	0
Construction Administration Totals			\$18,370	\$0	\$18,370	\$0	\$0	\$0	\$0	\$0

Albany International Airport - Terminal A Renovations

LABOR BREAKDOWN

Ellana - Cost Estimating

Date: 11.02.2022

Scope	Labor Dollars		Labor Hours						
	Labor subtotal (loaded)	Sub Task Totals (loaded)	PIC	PM	PA	PA	PD	PD	QA/QC
Multiplier: 2.09 Unloaded Billing Rates			Clive Tyse 84.13	TBD 80	TBD 6346	TBD 4808			
PART 1: DESIGN SERVICES 42 weeks									
Project Administration & Management 42									
1.00 Project Management	\$0								
2.00 Funding and Grants	\$0								
Project Administration & Management Hours		0 hrs	0	0	0	0	0	0	0
Project Administration & Management Totals	\$0		\$0	\$0	\$0	\$0	\$0	\$0	\$0
Project Definition 6 weeks									
1.00 Existing Conditions	\$0								
2.00 Programming	\$0								
3.00 Regulatory Analysis	\$0								
4.00 Sustainability	\$0								
5.00 Preliminary Design	\$7,068								
5.01 Conceptual Design		\$0							
5.02 Cost Estimate		\$7,068	10	8	12	8			
5.03 Code Impact/Analysis for 3 Approaches		\$0							
5.05 Preliminary CSPP		\$0							
Project Definition Hours		30 hrs	10	8	12	8	0	0	0
Project Definition Totals	\$7,068		\$2,263	\$1,722	\$2,048	\$1,035	\$0	\$0	\$0
30% Design - Schematic Design 8 weeks									
1.00 Architectural Documentation & Design	\$0								
2.00 Cost Estimating	\$11,441								
2.01 Statement of probable cost		\$11,441	8	16	12	32			
2.02 Value Management, Cost Review		\$0							
3.00 Sustainability	\$0								
4.00 Quality assurance and Quality Control	\$0								
5.00 Regulatory	\$0								
30% Design - Schematic Design Hours		68 hrs	8	16	12	32	0	0	0
30% Design - Schematic Design Totals	\$11,441		\$1,810	\$3,443	\$2,048	\$4,139	\$0	\$0	\$0
60% Design - Design Development 10 weeks									
1.00 Architectural Documentation & Design	\$0								
2.00 Cost Estimating	\$13,845								
2.01 Cost Estimate		\$13,845	8	24	16	32			
2.02 Value Management, Cost Review		\$0							
3.00 Sustainability	\$0								
4.00 Quality assurance and Quality Control	\$0								
5.00 Regulatory	\$0								
60% Design - Design Development Hours		80 hrs	8	24	16	32	0	0	0
60% Design - Design Development Totals	\$13,845		\$1,810	\$5,165	\$2,731	\$4,139	\$0	\$0	\$0
100% Design - Construction Documents 14 weeks									
1.00 Architectural Documentation & Design	\$0								
1.12 90% Progress Stop and Plot, Interim Coordination		\$0							
2.00 Cost Estimating	\$18,908								
2.01 90% Progress Cost Estimate (Design Team Stop and Plot)		\$14,868	8	20	24	36			
2.02 Value Management, Cost Review		\$0							
2.03 100% Cost Review/Update		\$4,040	4	5	6	8			
2.04 Value Management, Cost Review		\$0							
3.00 Sustainability	\$0								
4.00 Quality assurance and Quality Control	\$0								
5.00 Regulatory	\$0								
100% Design - Construction Documents Hours		111 hrs	12	25	30	44	0	0	0
100% Design - Construction Documents Totals	\$18,908		\$2,716	\$5,380	\$5,121	\$5,691	\$0	\$0	\$0
Bidding 6 weeks									
PART 2: CONSTRUCTION SERVICES 60 weeks									
Construction Administration 14 weeks									
Construction Administration Hours		0 hrs	0	0	0	0	0	0	0
Construction Administration Totals	\$0		\$0	\$0	\$0	\$0	\$0	\$0	\$0

Albany International Airport - Terminal A Renovations

LABOR BREAKDOWN

Code Red

Date: 11.02.2022

Scope	Labor Dollars		Labor Hours					
	Labor subtotal (loaded)	Sub Task Totals (loaded)	PIC Carl Nelson	PM Joseph Igoe	PC Nicholas Ostrowski			
Multiplier: 2.5 Unloaded Billing Rates			110.58	44.51	38.94			
PART 1: DESIGN SERVICES 42 weeks								
Project Administration & Management								
Project Definition 6 weeks								
1.00 Existing Conditions	\$3,877							
1.01 Review of Existing Conditions Documents and Information Provided by ACAA		\$775	2	2				
1.02 Existing facility due diligence		\$3,102	8	8				
1.03 Laser Scanning		\$0						
1.04 Building Modeling		\$0						
1.05 GeoTechnical and Civil Oversight/Coordination		\$0						
2.00 Programming	\$0							
2.01 Program Confirmation		\$0						
2.02 Design Narrative		\$0						
2.03 Concept Phasing/Feasibility Diagrams		\$0						
3.00 Regulatory Analysis	\$2,053							
3.01 Provide Outline, schedule and Narratives of all relevant FAA AHJ and Environment		\$499	1	2				
3.02 Prepare Outline Code Report and Existing Conditions Overview		\$1,554	2	2	8			
4.00 Sustainability	\$0							
5.00 Preliminary Design	\$0							
Project Definition Hours		36 hrs	13	14	8	0	0	0
Project Definition Totals	\$5,931		\$3,594	\$1,558	\$779	\$0	\$0	\$0
30% Design - Schematic Design 8 weeks								
1.00 Architectural Documentation & Design	\$0							
2.00 Cost Estimating	\$0							
3.00 Sustainability	\$0							
4.00 Quality assurance and Quality Control	\$0							
4.01 Design team QAQC		\$0						
5.00 Regulatory	\$6,328							
5.01 Updated Code Report, Draft Life Safety Plans		\$6,328	8	16	24			
6.00 Consultant Specific Scope	\$0							
6.01 Trade Specific Scope		\$0						
30% Design - Schematic Design Hours		48 hrs	8	16	24	0	0	0
30% Design - Schematic Design Totals	\$6,328		\$2,212	\$1,780	\$2,336	\$0	\$0	\$0
60% Design - Design Development 10 weeks								
1.00 Architectural Documentation & Design	\$0							
2.00 Cost Estimating	\$0							
3.00 Sustainability	\$0							
4.00 Quality assurance and Quality Control	\$0							
5.00 Regulatory	\$4,998							
5.01 Updated Code Report, Updated Life Safety Plans		\$4,611	4	14	20			
5.02 Prep and Attend Information Meeting with AHJ (Virtual)		\$388	1	1				
6.00 Consultant Specific Scope	\$0							
60% Design - Design Development Hours		40 hrs	5	15	20	0	0	0
60% Design - Design Development Totals	\$4,998		\$1,382	\$1,669	\$1,947	\$0	\$0	\$0
100% Design - Construction Documents 14 weeks								
1.00 Architectural Documentation & Design	\$4,386							
1.12 90% Progress Stop and Plot, Interim Coordination		\$4,386	5	13	16			
2.00 Cost Estimating	\$0							
3.00 Sustainability	\$0							
4.00 Quality assurance and Quality Control	\$0							
5.00 Regulatory	\$1,582							
5.01 Updated Code Report, Updated Life Safety Plans		\$1,582	2	4	6			
6.00 Consultant Specific Scope	\$0							
6.01 Trade Specific Scope		\$0						
100% Design - Construction Documents Hours		46 hrs	7	17	22	0	0	0
100% Design - Construction Documents Totals	\$5,969		\$1,935	\$1,892	\$2,142	\$0	\$0	\$0

Bidding		0 weeks														
1.00	Bidding	\$0														
2.00	Consultant Specific Scope	\$775														
2.01	Trade Specific	\$775														
Bidding Hours			4 hrs	2	2	0	0	0	0	0	0	0	0	0	0	0
Bidding Totals		\$775				\$165	\$225	\$0	\$0	\$0	\$0	\$0	\$0	\$0	\$0	\$0

PART 2: CONSTRUCTION SERVICES		42 weeks														
Construction Administration		16 months														
1.00	Submittals	\$0														
2.00	Sustainability	\$0														
2.01	LEED	\$0														
3.00	Request for Information (RFI)	\$1,558														
3.01	RFI review		\$890			8										
3.02	Supplemental information		\$668			6										
4.00	Field Observation	\$0														
5.00	Construction Changes	\$0														
6.00	Construction meetings	\$0														
7.00	Contractor pay requisition	\$0														
7.01	Pay Req. review		\$0													
8.00	Project Close out	\$0														
Construction Administration Hours			14 hrs	0	34	0	0	0	0	0	0	0	0	0	0	0
Construction Administration Totals		\$1,558				\$0	\$1,558	\$0	\$0	\$0	\$0	\$0	\$0	\$0	\$0	\$0

**Albany International Airport -
EXPENSES**

Fennick McCredie Architecture

Date: 11/21/2022

	Expense	Units	Cost	Qty	Total	Notes
Direct Expenses					\$0.00	
	Mileage	MI	\$0.59	8448	\$4,942.08	Assume 24 Round Trips
	Hotel	Ea	\$114.00	9	\$1,026.00	3 Overnights, 3 ppl
	Meals (per Diem)	Ea	\$51.75	40	\$2,070.00	Assume 40 ppl/days meals
	Reproductions	LS			\$2,000.00	
	Other	LS			\$1,000.00	
					\$11,038.08	
Sub-Cons					\$0.00	
Estimated Total:					\$11,038.08	

Notes:

1. Refer to MJ Proposal and Worksheet for detail on Expenses and Sub-Consultant Costs

CLAIM FORM

TAX EXEMPT TAX ID NO. 14-1768979		LEAVE THESE SPACES BLANK	
SOLD TO: ALBANY COUNTY AIRPORT AUTHORITY		RECEIVED FOR AUDIT	AMOUNT
CLAIMANT		ORDER	EXTENSIONS
		CLAIM APPROVED THIS DATE	AMOUNT
ADDRESS		SIGNED:	AUDITOR
		DATE PAID:	CHECK NO.
OFFICE OR DEPARTMENT	CODE		
P.O. NO.	QUANTITY	DESCRIPTION OF ITEMS OR WORK PERFORMED	UNIT PRICE AMOUNT
		<i>LIST INVOICE OR SALES SLIP NUMBERS IF AVAILABLE</i>	
			TOTAL \$

Claims must be rendered in DUPLICATE to head of department for which services or materials are furnished.

CERTIFICATE OF CLAIMANT

I, do hereby certify
 (Print or type name of person certifying, whether claimant, member of firm or officer of corporation)
 that I am

.....(if individual, leave blank, if partner, write "a member of the firm [naming the firm]"; if corporation, title of officer and name of corporation) and that this claim is true and correct and that the amount claimed is due, owing and unpaid; that the services were actually rendered, the disbursements actually and necessarily made or the supplies or equipment actually delivered and that the consideration has passed to the Albany County Airport Authority as stated herein; that no Federal or State taxes for which the Authority is exempt are included in the purchase price. Certified True and Correct.

NOTICE TO INDIVIDUAL CLAIMANTS	
If this claim is being submitted for payment to an individual for services rendered or for any reason other than reimbursement of expenses incurred on Authority business, you must supply your Fed. Tax ID No. or your Social Security No. in the space provided.	
Federal Tax Identification No. or Social Security No.	

.....
CLAIMANT

.....
BY

Dated.....20.....

CERTIFICATE OF APPROVAL BY DEPARTMENT HEAD OR OFFICER THROUGH WHOM CLAIM ORIGINATED

I hereby certify that the services enumerated in this claim were actually rendered by the persons named; the disbursements made; or the supplies or equipment were actually delivered, accepted, counted and inspected by me and are satisfactory and of the quantity and quality specified in such claim; that the contract price has been earned; that the services, disbursements, supplies or equipment were necessary and have been, or will be applied to the use of this department.

Dated....., 20.....

.....
HEAD OF DEPARTMENT

CLAIM NO. _____

SCHEDULE "C"
INSURANCE CERTIFICATE(S)



CERTIFICATE OF LIABILITY INSURANCE

DATE (MM/DD/YYYY)
01/11/2023

THIS CERTIFICATE IS ISSUED AS A MATTER OF INFORMATION ONLY AND CONFERS NO RIGHTS UPON THE CERTIFICATE HOLDER. THIS CERTIFICATE DOES NOT AFFIRMATIVELY OR NEGATIVELY AMEND, EXTEND OR ALTER THE COVERAGE AFFORDED BY THE POLICIES BELOW. THIS CERTIFICATE OF INSURANCE DOES NOT CONSTITUTE A CONTRACT BETWEEN THE ISSUING INSURER(S), AUTHORIZED REPRESENTATIVE OR PRODUCER, AND THE CERTIFICATE HOLDER.

IMPORTANT: If the certificate holder is an ADDITIONAL INSURED, the policy(ies) must have ADDITIONAL INSURED provisions or be endorsed. If SUBROGATION IS WAIVED, subject to the terms and conditions of the policy, certain policies may require an endorsement. A statement on this certificate does not confer rights to the certificate holder in lieu of such endorsement(s).

PRODUCER 781-245-5400 Poole Professional B&B of MA 107 Audubon Rd, #2, Ste 305 Wakefield, MA 01880 Cameron W. Poole	CONTACT NAME: Cameron Poole PHONE (A/C, No, Ext): 781-245-5400 FAX (A/C, No): 781-245-5463 E-MAIL ADDRESS:	
	INSURER(S) AFFORDING COVERAGE	
INSURED Fennick McCredie Architecture Ltd 70 Franklin Street Boston, MA 02110	INSURER A: Travelers Indemnity Co of CT NAIC # 25682	INSURER B: Safety Insurance Company NAIC # 39454
	INSURER C: Travelers Prop Casualty Co Am NAIC # 25674	INSURER D: Travelers Indemnity Co of CT NAIC # 25682
	INSURER E: XL Specialty Insurance Company NAIC # 37885	INSURER F:

COVERAGES CERTIFICATE NUMBER: REVISION NUMBER:

THIS IS TO CERTIFY THAT THE POLICIES OF INSURANCE LISTED BELOW HAVE BEEN ISSUED TO THE INSURED NAMED ABOVE FOR THE POLICY PERIOD INDICATED. NOTWITHSTANDING ANY REQUIREMENT, TERM OR CONDITION OF ANY CONTRACT OR OTHER DOCUMENT WITH RESPECT TO WHICH THIS CERTIFICATE MAY BE ISSUED OR MAY PERTAIN, THE INSURANCE AFFORDED BY THE POLICIES DESCRIBED HEREIN IS SUBJECT TO ALL THE TERMS, EXCLUSIONS AND CONDITIONS OF SUCH POLICIES. LIMITS SHOWN MAY HAVE BEEN REDUCED BY PAID CLAIMS.

INSR LTR	TYPE OF INSURANCE	ADDL SUBR INSD WVD	POLICY NUMBER	POLICY EFF (MM/DD/YYYY)	POLICY EXP (MM/DD/YYYY)	LIMITS
A	<input checked="" type="checkbox"/> COMMERCIAL GENERAL LIABILITY <input type="checkbox"/> CLAIMS-MADE <input checked="" type="checkbox"/> OCCUR GEN'L AGGREGATE LIMIT APPLIES PER: <input type="checkbox"/> POLICY <input checked="" type="checkbox"/> PROJECT <input type="checkbox"/> LOC OTHER:	X X	6804H394399	11/12/2022	11/12/2023	EACH OCCURRENCE \$ 2,000,000 DAMAGE TO RENTED PREMISES (Ea occurrence) \$ 1,000,000 MED EXP (Any one person) \$ 10,000 PERSONAL & ADV INJURY \$ 2,000,000 GENERAL AGGREGATE \$ 4,000,000 PRODUCTS - COMP/OP AGG \$ 4,000,000
B	AUTOMOBILE LIABILITY <input type="checkbox"/> ANY AUTO OWNED AUTOS ONLY <input checked="" type="checkbox"/> HIRED AUTOS ONLY <input checked="" type="checkbox"/> SCHEDULED AUTOS <input checked="" type="checkbox"/> NON-OWNED AUTOS ONLY	X X	1417504	06/02/2022	06/02/2023	COMBINED SINGLE LIMIT (Ea accident) \$ 1,000,000 BODILY INJURY (Per person) \$ BODILY INJURY (Per accident) \$ PROPERTY DAMAGE (Per accident) \$
A	<input checked="" type="checkbox"/> UMBRELLA LIAB <input checked="" type="checkbox"/> OCCUR <input type="checkbox"/> EXCESS LIAB <input type="checkbox"/> CLAIMS-MADE <input checked="" type="checkbox"/> DED <input checked="" type="checkbox"/> RETENTION \$ 10,000	X X	CUP7691Y645	11/12/2022	11/12/2023	EACH OCCURRENCE \$ 9,000,000 AGGREGATE \$ 9,000,000
C	WORKERS COMPENSATION AND EMPLOYERS' LIABILITY ANY PROPRIETOR/PARTNER/EXECUTIVE OFFICER/MEMBER EXCLUDED? (Mandatory in NH) If yes, describe under DESCRIPTION OF OPERATIONS below	Y/N N N/A	X UB8J022197	11/12/2022	11/12/2023	<input checked="" type="checkbox"/> PER STATUTE <input type="checkbox"/> OTHER E.L. EACH ACCIDENT \$ 1,000,000 E.L. DISEASE - EA EMPLOYEE \$ 1,000,000 E.L. DISEASE - POLICY LIMIT \$ 1,000,000
D	Arch/Eng Prof Liab incl Pollution		DPR5004500	11/12/2022	11/12/2023	Per Claim \$ 5,000,000 Aggregate \$ 5,000,000

DESCRIPTION OF OPERATIONS / LOCATIONS / VEHICLES (ACORD 101, Additional Remarks Schedule, may be attached if more space is required)
Re: FM Project #1236 - ALB Rehabilitation of Concourse A (ALB Contract No. S-22-1127).

Please see page 2 for additional insured.

CERTIFICATE HOLDER ALBAN-8 Albany County Airport Authority 737 Albany Shaker Road Main Terminal, 3rd Floor Albany, NY 12211	CANCELLATION SHOULD ANY OF THE ABOVE DESCRIBED POLICIES BE CANCELLED BEFORE THE EXPIRATION DATE THEREOF, NOTICE WILL BE DELIVERED IN ACCORDANCE WITH THE POLICY PROVISIONS. AUTHORIZED REPRESENTATIVE
---	--

NOTEPAD:HOLDER CODE **ALBAN-8**
INSURED'S NAME **Fennick McCredie Architecture Ltd****FENNI-1**
OP ID: CWPPAGE 2
Date **01/11/2023**

ALBANY COUNTY AIRPORT AUTHORITY AND ITS AGENT, AFCA AIRPORTS MANAGEMENT, LLC, THE COUNTY OF ALBANY, THE FEDERAL AVIATION ADMINISTRATION, and THE STATE OF NEW YORK are included as additional insured per written contract on the general, auto and umbrella liability policies subject to policy terms and conditions. 30-day notice of cancellation applies. Waiver of subrogation applies where agreed upon per written contract.

POLICY NUMBER: 680-4H394399-22-47

EFFECTIVE DATE: 11/12/2022

ISSUE DATE: 09/30/2022

LISTING OF FORMS, ENDORSEMENTS AND SCHEDULE NUMBERS

THIS LISTING SHOWS THE NUMBER OF FORMS, SCHEDULES AND ENDORSEMENTS
BY LINE OF BUSINESS

* IL T0 25 08 01 RENEWAL CERTIFICATE
* MP T0 01 02 05 BUSINESSOWNERS COVERAGE PART DECLARATIONS
* IL T8 01 01 01 FORMS ENDORSEMENTS AND SCHEDULE NUMBERS
IL T3 15 09 07 COMMON POLICY CONDITIONS

BUSINESSOWNERS

MP T1 30 02 05 TABLE OF CONTENTS - BUSINESSOWNERS COVERAGE PART -
DELUXE PLAN
MP P0 06 09 15 ARCHITECTS, ENGINEERS AND SURVEYORS PROPERTY
ENHANCEMENT
MP P0 07 09 15 ARCHITECTS, ENGINEERS AND SURVEYORS FLOOD ENDORSEMENT
MP P0 08 09 15 ARCHITECTS, ENGINEERS AND SURVEYORS EARTHQUAKE
ENDORSEMENT
MP T1 02 02 05 BUSINESSOWNERS PROPERTY COVERAGE SPECIAL FORM
MP T1 05 02 05 AMENDATORY PROVISIONS - OFFICES
* MP T1 75 03 19 WINDSTORM OR HAIL PERCENTAGE DEDUCTIBLE
* MP T3 07 03 97 PROTECTIVE SAFEGUARDS ENDORSEMENT FOR SPRINKLERED
LOCATIONS AND RESTAURANTS
MP T3 25 01 21 FEDERAL TERRORISM RISK INSURANCE ACT DISCLOSURE
MP T3 50 11 06 EQUIPMENT BREAKDOWN - SERVICE INTERRUPTION LIMITATION
MP T3 56 02 08 AMENDATORY PROVISIONS - GREEN BUILDING AND BUSINESS
PERSONAL PROP COV ENHANCEMENTS
* MP T1 55 02 05 EMPLOYEE DISHONESTY AND FORGERY OR ALTERATION
INCREASED LIMIT
MP T5 31 05 10 MASSACHUSETTS CHANGES
CP T9 16 09 99 MASSACHUSETTS CHANGES - "POLLUTANTS"

COMMERCIAL GENERAL LIABILITY

* CG D4 69 02 19 TOT AGG LIMIT OTHER THAN PROJECTS
CG T0 34 02 19 TABLE OF CONTENTS - COMMERCIAL GENERAL LIABILITY
COVERAGE FORM CG T1 00 02 19
CG T1 00 02 19 COMMERCIAL GENERAL LIABILITY COVERAGE FORM
CG D3 09 02 19 AMENDATORY ENDORSEMENT - PRODUCTS-COMPLETED OPERATIONS
HAZARD
CG D6 75 02 19 AMEND-WHO IS INS-ARCHIT/ENG/SURVEY ACTIV
* CG D9 10 09 21 AMENDMENT OF INTELLECTUAL PROPERTY EXCLUSION
GN 00 13 02 19 EXTENSION OF COVERAGE - BODILY INJURY
CG D2 03 12 97 AMEND - NON CUMULATION OF EACH OCC
* CG T8 01 11 22 GENERAL PURPOSE ENDORSEMENT
* CG T8 02 11 22 GENERAL PURPOSE ENDORSEMENT
* CG T8 03 11 22 GENERAL PURPOSE ENDORSEMENT

* TEXT IN THIS FORM HAS CHANGED, OR THE FORM WAS NOT ON POLICY BEFORE.

POLICY NUMBER: 680-4H394399-22-47

EFFECTIVE DATE: 11/12/2022

ISSUE DATE: 09/30/2022

COMMERCIAL GENERAL LIABILITY (CONTINUED)

* CG T8 04 11 22 GENERAL PURPOSE ENDORSEMENT
* CG T8 05 11 22 GENERAL PURPOSE ENDORSEMENT
CG D3 79 02 19 XTEND ENDORSEMENT FOR ARCHITECTS, ENGINEERS AND
SURVEYORS
CG D4 18 11 09 EXCLUSION - PROFESSIONAL SERVICES - ARCHITECTS,
ENGINEERS OR SURVEYORS
CG D4 21 07 08 AMEND CONTRAL LIAB EXCL - EXC TO NAMED INS
CG D6 18 10 11 EXCLUSION - VIOLATION OF CONSUMER FINANCIAL PROTECTION
LAWS
* CG D6 99 08 13 AMEND LIQ EXCL-EXCEPT SCHED PREM/ACTIV
CG D1 42 02 19 EXCLUSION - DISCRIMINATION

MULTIPLE SUBLINE ENDORSEMENTS

CG T3 33 11 03 LIMITATION WHEN TWO OR MORE POLICIES APPLY

INTERLINE ENDORSEMENTS

* IL T0 63 07 22 ACTUAL CASH VALUE
* IL T3 20 05 19 NOTICE OF CANCELLATION OR NONRENEWAL PROVIDED BY US
IL T4 12 03 15 AMNDT COMMON POLICY COND-PROHIBITED COVG
IL T4 14 01 21 CAP ON LOSSES FROM CERTIFIED ACTS OF TERRORISM
IL T4 27 06 19 ADDITIONAL BENEFITS
IL T4 40 10 20 PROTECTION OF PROPERTY
IL T3 82 05 13 EXCLUSION OF LOSS DUE TO VIRUS OR BACTERIA
* IL T8 00 11 22 GENERAL PURPOSE ENDORSEMENT
IL 00 21 09 08 NUCLEAR ENERGY LIABILITY EXCLUSION ENDORSEMENT (BROAD
FORM)
IL T4 00 05 19 DESIG PERSON, ORG-NOTICE PROVIDED BY US

POLICY HOLDER NOTICES

* PN T4 54 01 08 IMPORTANT NOTICE REGARDING INDEPENDENT AGENT AND
BROKER COMPENSATION
* PN U4 37 03 22 NOTICE OF CHANGE IN POLICY TERMS AMENDMENT OF
INTELLECTUAL PROPERTY EXCLUSION
PN MP 57 04 17 IMP NOT PROT SAFEGUARDS SPRK AND REST
PN MP 38 01 11 IMPORTANT NOTICE - JURISDICTIONAL INSPECTIONS

* TEXT IN THIS FORM HAS CHANGED, OR THE FORM WAS NOT ON POLICY BEFORE.

THIS ENDORSEMENT CHANGES THE POLICY. PLEASE READ IT CAREFULLY.

ADDITIONAL INSURED – OWNERS, LESSEES OR CONTRACTORS – COMPLETED OPERATIONS

This endorsement modifies insurance provided under the following:

COMMERCIAL GENERAL LIABILITY COVERAGE PART

SCHEDULE

Name Of Additional Insured Person(s) Or Organization(s):

Any person or organization that you agree in a written contract to include as an additional insured on this Coverage Part for "bodily injury" or "property damage" included in the products-completed operations hazard, provided that such contract was signed by you before, and is in effect when, the "bodily injury or "property damage" occurs.

Location And Description Of Completed Operations

Any project to which a written contract with the Additional Insured Person(s) or Organization(s) in the Schedule applies.

Information required to complete this Schedule, if not shown above, will be shown in the Declarations.

Section II – Who Is An Insured is amended to include as an additional insured the person(s) or organization(s) shown in the Schedule, but only with respect to liability for "bodily injury" or "property damage" caused, in whole or in part, by "your work" at the

location designated and described in the schedule of this endorsement performed for that additional insured and included in the "products-completed operations hazard".

THIS ENDORSEMENT CHANGES THE POLICY. PLEASE READ IT CAREFULLY.

ADDITIONAL INSURED – OWNERS, LESSEES OR CONTRACTORS – SCHEDULED PERSON OR ORGANIZATION

This endorsement modifies insurance provided under the following:

COMMERCIAL GENERAL LIABILITY COVERAGE PART

SCHEDULE

Names of Additional Insured Person(s) or Organization(s):

Any person or organization that you agree in a written contract to include as an additional insured on this Coverage Part, provided that such written contract was signed by you before, and is in effect when, the "bodily injury" or "property damage" occurs or the "personal injury" or "advertising injury" offense is committed.

Location of Covered Operations:

Any project to which a written contract with the Additional Insured Person(s) or Organization(s) in the Schedule applies.

(Information required to complete this Schedule, if not shown above, will be shown in the Declarations.)

A. Section II – Who Is An Insured is amended to include as an additional insured the person(s) or organization(s) shown in the Schedule, but only with respect to liability for "bodily injury", "property damage", "personal injury" or "advertising injury" caused, in whole or in part, by:

1. Your acts or omissions; or
2. The acts or omissions of those acting on your behalf;

in the performance of your ongoing operations for the additional insured(s) at the location(s) designated above.

B. With respect to the insurance afforded to these additional insureds, the following additional exclusions apply:

This insurance does not apply to "bodily injury" or "property damage" occurring, or "personal injury" or "advertising injury" arising out of an offense committed, after:

1. All work, including materials, parts or equipment furnished in connection with such work, on the project (other than service, maintenance or repairs) to be performed by or on behalf of the additional insured(s) at the location of the covered operations has been completed; or
2. That portion of "your work" out of which the injury or damage arises has been put to its intended use by any person or organization other than another contractor or subcontractor engaged in performing operations for a principal as a part of the same project.

CG D3 61 03 05

Copyright 2005 The St. Paul Travelers Companies, Inc. All rights reserved.

CG T8 04 11 22 includes copyrighted material of Insurance Services Office, Inc. with its permission.

venture or limited liability company that is not shown as a Named Insured in the Declarations. This paragraph does not apply to any such partnership, joint venture or limited liability company that otherwise qualifies as an insured under Section II – Who Is An Insured.

SECTION III – LIMITS OF INSURANCE

1. The Limits of Insurance shown in the Declarations and the rules below fix the most we will pay regardless of the number of:
 - a. Insureds;
 - b. Claims made or "suits" brought; or
 - c. Persons or organizations making claims or bringing "suits".
2. The General Aggregate Limit is the most we will pay for the sum of:
 - a. Medical expenses under Coverage C;
 - b. Damages under Coverage A, except damages because of "bodily injury" or "property damage" included in the "products-completed operations hazard"; and
 - c. Damages under Coverage B.
3. The Products-Completed Operations Aggregate Limit is the most we will pay under Coverage A for damages because of "bodily injury" and "property damage" included in the "products-completed operations hazard".
4. Subject to Paragraph 2. above, the Personal And Advertising Injury Limit is the most we will pay under Coverage B for the sum of all damages because of all "personal injury" and "advertising injury" sustained by any one person or organization.
5. Subject to Paragraph 2. or 3. above, whichever applies, the Each Occurrence Limit is the most we will pay for the sum of:
 - a. Damages under Coverage A; and
 - b. Medical expenses under Coverage C; because of all "bodily injury" and "property damage" arising out of any one "occurrence".

For the purposes of determining the applicable Each Occurrence Limit, all related acts or omissions committed in providing or failing to provide first aid or "Good Samaritan services" to any one person will be deemed to be one "occurrence".
6. Subject to Paragraph 5. above, the Damage To Premises Rented To You Limit is the most we will pay under Coverage A for damages because of "premises damage" to any one premises. The Damage To Premises Rented To You Limit will be:

- a. The amount shown for the Damage To Premises Rented To You Limit in the Declarations of this Coverage Part; or
- b. \$300,000 if no amount is shown for the Damage To Premises Rented To You Limit in the Declarations of this Coverage Part.

7. Subject to Paragraph 5. above, the Medical Expense Limit is the most we will pay under Coverage C for all medical expenses because of "bodily injury" sustained by any one person.

The Limits of Insurance of this Coverage Part apply separately to each consecutive annual period and to any remaining period of less than 12 months, starting with the beginning of the policy period shown in the Declarations, unless the policy period is extended after issuance for an additional period of less than 12 months. In that case, the additional period will be deemed part of the last preceding period for purposes of determining the Limits of Insurance.

SECTION IV – COMMERCIAL GENERAL LIABILITY CONDITIONS

1. **Bankruptcy**
Bankruptcy or insolvency of the insured or of the insured's estate will not relieve us of our obligations under this Coverage Part.
2. **Duties In The Event Of Occurrence, Offense, Claim Or Suit**
 - a. You must see to it that we are notified as soon as practicable of an "occurrence" or an offense which may result in a claim. To the extent possible, notice should include:
 - (1) How, when and where the "occurrence" or offense took place;
 - (2) The names and addresses of any injured persons and witnesses; and
 - (3) The nature and location of any injury or damage arising out of the "occurrence" or offense.
 - b. If a claim is made or "suit" is brought against any insured, you must:
 - (1) Immediately record the specifics of the claim or "suit" and the date received; and
 - (2) Notify us as soon as practicable.

You must see to it that we receive written notice of the claim or "suit" as soon as practicable.
 - c. You and any other involved insured must:
 - (1) Immediately send us copies of any demands, notices, summonses or legal papers received in connection with the claim or "suit";

4. Other Insurance

If valid and collectible other insurance is available to the insured for a loss we cover under Coverages **A** or **B** of this Coverage Part, our obligations are limited as described in Paragraphs **a.** and **b.** below.

As used anywhere in this Coverage Part, other insurance means insurance, or the funding of losses, that is provided by, through or on behalf of:

- (i) Another insurance company;
- (ii) Us or any of our affiliated insurance companies, except when the Non cumulation of Each Occurrence Limit provision of Paragraph **5.** of Section **III** – Limits Of Insurance or the Non cumulation of Personal and Advertising Injury Limit provision of Paragraph **4.** of Section **III** – Limits of Insurance applies because the Amendment – Non Cumulation Of Each Occurrence Limit Of Liability And Non Cumulation Of Personal And Advertising Injury Limit endorsement is included in this policy;
- (iii) Any risk retention group; or
- (iv) Any self-insurance method or program, in which case the insured will be deemed to be the provider of other insurance.

Other insurance does not include umbrella insurance, or excess insurance, that was bought specifically to apply in excess of the Limits of Insurance shown in the Declarations of this Coverage Part.

As used anywhere in this Coverage Part, other insurer means a provider of other insurance. As used in Paragraph **c.** below, insurer means a provider of insurance.

a. Primary Insurance

This insurance is primary except when Paragraph **b.** below applies. If this insurance is primary, our obligations are not affected unless any of the other insurance is also primary. Then, we will share with all that other insurance by the method described in Paragraph **c.** below, except when Paragraph **d.** below applies.

b. Excess Insurance

(1) This insurance is excess over:

- (a) Any of the other insurance, whether primary, excess, contingent or on any other basis:
 - (i) That is Fire, Extended Coverage, Builder's Risk, Installation Risk or similar coverage for "your work";

(ii) That is insurance for "premises damage";

(iii) If the loss arises out of the maintenance or use of aircraft, "autos" or watercraft to the extent not subject to any exclusion in this Coverage Part that applies to aircraft, "autos" or watercraft;

(iv) That is insurance available to a premises owner, manager or lessor that qualifies as an insured under Paragraph **4.** of Section **II** – Who Is An Insured, except when Paragraph **d.** below applies; or

(v) That is insurance available to an equipment lessor that qualifies as an insured under Paragraph **5.** of Section **II** – Who Is An Insured, except when Paragraph **d.** below applies.

(b) Any of the other insurance, whether primary, excess, contingent or on any other basis, that is available to the insured when the insured is an additional insured, or is any other insured that does not qualify as a named insured, under such other insurance.

(2) When this insurance is excess, we will have no duty under Coverages **A** or **B** to defend the insured against any "suit" if any other insurer has a duty to defend the insured against that "suit". If no other insurer defends, we will undertake to do so, but we will be entitled to the insured's rights against all those other insurers.

(3) When this insurance is excess over other insurance, we will pay only our share of the amount of the loss, if any, that exceeds the sum of:

(a) The total amount that all such other insurance would pay for the loss in the absence of this insurance; and

(b) The total of all deductible and self-insured amounts under all that other insurance.

(4) We will share the remaining loss, if any, with any other insurance that is not described in this Excess Insurance provision and was not bought specifically to apply in excess of the Limits of Insurance shown in the Declarations of this Coverage Part.

c. Method Of Sharing

If all of the other insurance permits contribution by equal shares, we will follow this method also. Under this approach each insurer contributes equal amounts until it has paid its applicable limit of insurance or none of the loss remains, whichever comes first.

If any of the other insurance does not permit contribution by equal shares, we will contribute by limits. Under this method, each insurer's share is based on the ratio of its applicable limit of insurance to the total applicable limits of insurance of all insurers.

d. Primary And Non-Contributory Insurance If Required By Written Contract

If you specifically agree in a written contract or agreement that the insurance afforded to an insured under this Coverage Part must apply on a primary basis, or a primary and non-contributory basis, this insurance is primary to other insurance that is available to such insured which covers such insured as a named insured, and we will not share with that other insurance, provided that:

- (1) The "bodily injury" or "property damage" for which coverage is sought occurs; and
- (2) The "personal and advertising injury" for which coverage is sought is caused by an offense that is committed;

subsequent to the signing of that contract or agreement by you.

5. Premium Audit

- a. We will compute all premiums for this Coverage Part in accordance with our rules and rates.
- b. Premium shown in this Coverage Part as advance premium is a deposit premium only. At the close of each audit period we will compute the earned premium for that period and send notice to the first Named Insured. The due date for audit and retrospective premiums is the date shown as the due date on the bill. If the sum of the advance and audit premiums paid for the policy period is greater than the earned premium, we will return the excess to the first Named Insured.
- c. The first Named Insured must keep records of the information we need for premium computation, and send us copies at such times as we may request.

6. Representations

By accepting this policy, you agree:

- a. The statements in the Declarations are accurate and complete;
- b. Those statements are based upon representations you made to us; and
- c. We have issued this policy in reliance upon your representations.

The unintentional omission of, or unintentional error in, any information provided by you which we relied upon in issuing this policy will not prejudice your rights under this insurance. However, this provision does not affect our right to collect additional premium or to exercise our rights of cancellation or nonrenewal in accordance with applicable insurance laws or regulations.

7. Separation Of Insureds

Except with respect to the Limits of Insurance, and any rights or duties specifically assigned in this Coverage Part to the first Named Insured, this insurance applies:

- a. As if each Named Insured were the only Named Insured; and
- b. Separately to each insured against whom claim is made or "suit" is brought.

8. Transfer Of Rights Of Recovery Against Others To Us

If the insured has rights to recover all or part of any payment we have made under this Coverage Part, those rights are transferred to us. The insured must do nothing after loss to impair them. At our request, the insured will bring "suit" or transfer those rights to us and help us enforce them.

9. When We Do Not Renew

If we decide not to renew this Coverage Part, we will mail or deliver to the first Named Insured shown in the Declarations written notice of the nonrenewal not less than 30 days before the expiration date.

If notice is mailed, proof of mailing will be sufficient proof of notice.

SECTION V – DEFINITIONS

- 1. "Advertisement" means a notice that is broadcast or published to the general public or specific market segments about your goods, products or services for the purpose of attracting customers or supporters. For the purposes of this definition:
 - a. Notices that are published include material placed on the Internet or on similar electronic means of communication; and
 - b. Regarding websites, only that part of a website that is about your goods, products or services for the purposes of attracting customers or supporters is considered an advertisement.

THIS ENDORSEMENT CHANGES THE POLICY. PLEASE READ IT CAREFULLY.

XTEND ENDORSEMENT FOR ARCHITECTS, ENGINEERS AND SURVEYORS

This endorsement modifies insurance provided under the following:

COMMERCIAL GENERAL LIABILITY COVERAGE PART

GENERAL DESCRIPTION OF COVERAGE – This endorsement broadens coverage. However, coverage for any injury, damage or medical expenses described in any of the provisions of this endorsement may be excluded or limited by another endorsement to this Coverage Part, and these coverage broadening provisions do not apply to the extent that coverage is excluded or limited by such an endorsement. The following listing is a general coverage description only. Read all the provisions of this endorsement and the rest of your policy carefully to determine rights, duties, and what is and is not covered.

- | | |
|--|--|
| <ul style="list-style-type: none"> A. Non-Owned Watercraft – 75 Feet Long Or Less B. Who Is An Insured – Unnamed Subsidiaries C. Who Is An Insured – Retired Partners, Members, Directors And Employees D. Who Is An Insured – Employees And Volunteer Workers – Bodily Injury To Co-Employees, Co-Volunteer Workers And Retired Partners, Members, Directors And Employees E. Who Is An Insured – Newly Acquired Or Formed Limited Liability Companies F. Blanket Additional Insured – Controlling Interest G. Blanket Additional Insured – Mortgagees, Assignees, Successors Or Receivers | <ul style="list-style-type: none"> H. Blanket Additional Insured – Governmental Entities – Permits Or Authorizations Relating To Premises I. Blanket Additional Insured – Governmental Entities – Permits Or Authorizations Relating To Operations J. Incidental Medical Malpractice K. Medical Payments – Increased Limit L. Amendment Of Excess Insurance Condition – Professional Liability M. Blanket Waiver Of Subrogation – When Required By Written Contract Or Agreement N. Contractual Liability – Railroads |
|--|--|

PROVISIONS

A. NON-OWNED WATERCRAFT – 75 FEET LONG OR LESS

1. The following replaces Paragraph (2) of Exclusion g., **Aircraft, Auto Or Watercraft**, in Paragraph 2. of **SECTION I – COVERAGES – COVERAGE A – BODILY INJURY AND PROPERTY DAMAGE LIABILITY**:

(2) A watercraft you do not own that is:

- (a) 75 feet long or less; and
- (b) Not being used to carry any person or property for a charge;

2. The following replaces Paragraph 2.e. of **SECTION II – WHO IS AN INSURED**:

e. Any person or organization that, with your express or implied consent, either

uses or is responsible for the use of a watercraft that you do not own that is:

- (1) 75 feet long or less; and
- (2) Not being used to carry any person or property for a charge;

B. WHO IS AN INSURED – UNNAMED SUBSIDIARIES

The following is added to **SECTION II – WHO IS AN INSURED**:

Any of your subsidiaries, other than a partnership or joint venture, that is not shown as a Named Insured in the Declarations is a Named Insured if:

- a. You are the sole owner of, or maintain an ownership interest of more than 50% in, such subsidiary on the first day of the policy period; and

occupational therapist or occupational therapy assistant, physical therapist or speech-language pathologist; or

- (b) First aid or "Good Samaritan services" by any of your "employees" or "volunteer workers", other than an employed or volunteer doctor. Any such "employees" or "volunteer workers" providing or failing to provide first aid or "Good Samaritan services" during their work hours for you will be deemed to be acting within the scope of their employment by you or performing duties related to the conduct of your business.
- 3. The following replaces the last sentence of Paragraph 5. of **SECTION III – LIMITS OF INSURANCE**:
For the purposes of determining the applicable Each Occurrence Limit, all related acts or omissions committed in providing or failing to provide "incidental medical services", first aid or "Good Samaritan services" to any one person will be deemed to be one "occurrence".
- 4. The following exclusion is added to Paragraph 2., **Exclusions**, of **SECTION I – COVERAGES – COVERAGE A – BODILY INJURY AND PROPERTY DAMAGE LIABILITY**:
Sale Of Pharmaceuticals
"Bodily injury" or "property damage" arising out of the violation of a penal statute or ordinance relating to the sale of pharmaceuticals committed by, or with the knowledge or consent of the insured.
- 5. The following is added to the **DEFINITIONS** Section:
"Incidental medical services" means:
 - a. Medical, surgical, dental, laboratory, x-ray or nursing service or treatment, advice or instruction, or the related furnishing of food or beverages; or
 - b. The furnishing or dispensing of drugs or medical, dental, or surgical supplies or appliances.
- 6. The following is added to Paragraph 4.b., **Excess Insurance**, of **SECTION IV – COMMERCIAL GENERAL LIABILITY CONDITIONS**:
This insurance is excess over any valid and collectible other insurance, whether primary, excess, contingent or on any other basis,

that is available to any of your "employees" for "bodily injury" that arises out of providing or failing to provide "incidental medical services" to any person to the extent not subject to Paragraph 2.a.(1) of Section II – Who Is An Insured.

K. MEDICAL PAYMENTS – INCREASED LIMIT

The following replaces Paragraph 7. of **SECTION III – LIMITS OF INSURANCE**:

- 7. Subject to Paragraph 5. above, the Medical Expense Limit is the most we will pay under Coverage C for all medical expenses because of "bodily injury" sustained by any one person, and will be the higher of:
 - a. \$10,000; or
 - b. The amount shown in the Declarations of this Coverage Part for Medical Expense Limit.

L. AMENDMENT OF EXCESS INSURANCE CONDITION – PROFESSIONAL LIABILITY

The following is added to Paragraph 4.b., **Excess Insurance**, of **SECTION IV – COMMERCIAL GENERAL LIABILITY CONDITIONS**:

This insurance is excess over any of the other insurance, whether primary, excess, contingent or on any other basis, that is Professional Liability or similar coverage, to the extent the loss is not subject to the professional services exclusion of Coverage A or Coverage B.

M. BLANKET WAIVER OF SUBROGATION – WHEN REQUIRED BY WRITTEN CONTRACT OR AGREEMENT

The following is added to Paragraph 8., **Transfer Of Rights Of Recovery Against Others To Us**, of **SECTION IV – COMMERCIAL GENERAL LIABILITY CONDITIONS**:

If the insured has agreed in a written contract or agreement to waive that insured's right of recovery against any person or organization, we waive our right of recovery against such person or organization, but only for payments we make because of:

- a. "Bodily injury" or "property damage" that occurs; or
- b. "Personal and advertising injury" caused by an offense that is committed; subsequent to the signing of that contract or agreement.

THIS ENDORSEMENT CHANGES THE POLICY. PLEASE READ IT CAREFULLY.

DESIGNATED PERSON OR ORGANIZATION – NOTICE OF CANCELLATION OR NONRENEWAL PROVIDED BY US

This endorsement modifies insurance provided under the following:

ALL COVERAGE PARTS INCLUDED IN THIS POLICY

SCHEDULE

CANCELLATION: Number of Days Notice: 30

WHEN WE DO NOT RENEW (Nonrenewal): Number of Days Notice: 30

PERSON OR ORGANIZATION:

ANY PERSON OR ORGANIZATION TO WHOM YOU HAVE AGREED IN A WRITTEN CONTRACT THAT NOTICE OF CANCELLATION OR NONRENEWAL OF THIS POLICY WILL BE GIVEN, BUT ONLY IF:

1. YOU SEND US A WRITTEN REQUEST TO PROVIDE SUCH NOTICE, INCLUDING THE NAME AND ADDRESS OF SUCH PERSON OR ORGANIZATION, AFTER THE FIRST NAMED INSURED RECEIVES NOTICE FROM US OF THE CANCELLATION OR NONRENEWAL OF THIS POLICY; AND
2. WE RECEIVE SUCH WRITTEN REQUEST AT LEAST 14 DAYS BEFORE THE BEGINNING OF THE APPLICABLE NUMBER OF DAYS SHOWN IN THIS SCHEDULE.

ADDRESS:

THE ADDRESS FOR THAT PERSON OR ORGANIZATION INCLUDED IN SUCH WRITTEN REQUEST FROM YOU TO US.

PROVISIONS

- A. If we cancel this policy for any legally permitted reason other than nonpayment of premium, and a number of days is shown for Cancellation in the Schedule above, we will mail notice of cancellation to the person or organization shown in such Schedule. We will mail such notice to the address shown in the Schedule above at least the number of days shown for Cancellation in such Schedule before the effective date of cancellation.
- B. If we do not renew this policy for any legally permitted reason other than nonpayment of premium, and a number of days is shown for When We Do Not Renew (Nonrenewal) in the Schedule above, we will mail notice of nonrenewal to the person or organization shown in such Schedule. We will mail such notice to the address shown in the Schedule above at least the number of days shown for When We Do Not Renew (Nonrenewal) in such Schedule before the effective date of nonrenewal.

FORMS AND ENDORSEMENTS SCHEDULE

Form Number	Edition Date	Description
* CA0001	(03/06)	Business Auto Coverage Form
* CA2386	(01/06)	Exclusion of Terrorism Above Minimum Statutory Limits
* IL0003	(04/98)	Calculation of Premium
* IL0017	(11/98)	Common Policy Conditions
* IL0021	(04/98)	Nuclear Energy Liability Exclusion Endorsement
* MM2026	(10/06)	Lessor - Additional Insured and Loss Payee - Massachusetts
* MM9911	(10/11)	Massachusetts Mandatory Endorsement
* MM9913	(10/06)	Auto Medical Payments Coverage - Massachusetts
* MM9917	(09/98)	Waiver of Deductible - Massachusetts
* MM9923	(09/98)	Rate Modification - Massachusetts
* MM9954	(09/98)	Underinsured Motorists Coverage - Massachusetts
* SCA005	(05/22)	Safety Commercial Auto Enhancer Plus
* SCA010	(04/15)	Safety Named Insured Endorsement Named Insured(s) FENNICK MCCREDIE ARCHIT LTD DEBORAH FENNICK

* Indicates that this endorsement is printed with this Policy Declaration.

THIS ENDORSEMENT CHANGES THE POLICY. PLEASE READ IT CAREFULLY.

SAFETY COMMERCIAL AUTO ENHANCER PLUS

This endorsement modifies insurance provided under the following:

BUSINESS AUTO COVERAGE FORM
MASSACHUSETTS MANDATORY ENDORSEMENT

With respect to coverage provided by this endorsement, the provisions of the Coverage Form apply unless modified by the endorsement.

1. COVERAGE EXTENSION FOR TRAILERS

SECTION I - COVERED AUTOS C.1. is replaced as follows:

"Trailers" with a load capacity of 3,000 pounds or less designed primarily for travel on public roads.

2. BROAD FORM NAMED INSURED

SECTION II – LIABILITY COVERAGE A.1. Who Is An Insured is amended to add:

- d. Any business entity newly acquired or formed by you during the policy period provided you own more than 50% of the voting stock or otherwise have a controlling interest in the business entity and the business entity is not separately insured for Business Auto Coverage. Coverage is extended up to a maximum of 180 days following acquisition or formation of the business entity or until expiration or termination of this policy.

3. EMPLOYEES AS INSUREDS

SECTION II – LIABILITY COVERAGE A.1. Who Is An Insured is amended to add:

- e. Any employee of yours while using a covered "auto" you do not own, hire, or borrow in your business or your personal affairs.

4. EMPLOYEE HIRED AUTOS

SECTION II – LIABILITY COVERAGE A.1. Who Is An Insured is amended to add:

- f. An "employee" of yours is an "insured" while operating an "auto" hired or rented under a contract or agreement in that "employee's" name, with your permission, while performing duties related to the conduct of your business.

SECTION IV - BUSINESS AUTO CONDITIONS B.5.b. is replaced as follows:

For Hired Auto Physical Damage Coverage, the following are deemed to be covered "autos" you own:

- (1) Any covered "auto" you lease, hire, rent or borrow; and
- (2) Any covered "auto" hired or rented by your "employee" under a contract in that individual "employee's" name, with your permission, while performing duties related to the conduct of your business.

However, any "auto" that is leased, hired, rented or borrowed with a driver is not a covered "auto".

5. PRIMARY AND NON-CONTRIBUTORY WITH OTHER INSURANCE – BLANKET ADDITIONAL INSURED

SECTION II – LIABILITY COVERAGE A.1. Who Is An Insured is amended to add:

- g.** Anyone who is required by a written contract to be an additional insured as respects the use of covered “autos”. The contract must be in effect during the policy term, and be executed prior to loss.

Exceptions:

- (1)** No additional contractual liability is assumed under this extension of coverage.
- (2)** This liability coverage does not apply to “bodily injury” or “property damage” which result from the operation of machinery that is located on, attached to, or part of any vehicle.

SECTION IV – BUSINESS AUTO CONDITIONS B.5. Other Insurance is amended to add:

- e.** Regardless of the provisions of item **a.** and item **d** of this part **5. Other Insurance**, if required by the written contract or agreement, coverage afforded to an additional insured will be primary and non-contributory. This coverage does not apply unless said written contract or agreement has been executed, or said permit has been issued, prior to the “bodily injury” or “property damage”. Coverage is not primary to other policies providing coverage to the additional insured. We will share with those policies by the method described in this policy.

6. LIABILITY COVERAGE EXTENSIONS - SUPPLEMENTARY PAYMENTS

SECTION II – LIABILITY COVERAGE A.2.a. Supplementary Payments Items **(2)** and **(4)** are replaced as follows:

- (2)** Up to \$3,500 for the cost of bail bonds (including bonds for related traffic law violations) required because of an “accident” we cover. We do not have to furnish these bonds.
- (4)** All reasonable expenses incurred by the “insured” at our request, including actual loss of earnings up to \$750 per day because of time off from work.

7. AMENDED FELLOW EMPLOYEE EXCLUSION

SECTION II – LIABILITY COVERAGE B.5. Fellow Employee is replaced as follows:

“Bodily injury” to any fellow employee of the “insured” arising out of and in the course of the fellow “employee’s” employment or while performing duties related to the conduct of your business.

However, we will cover “bodily injury” caused by your employee to his or her fellow employee if:

- a.** you have workers compensation insurance in force covering all your employees; and
- b.** the “bodily injury” results from the use of a covered “auto” you own or hire.

Coverage is excess over any other collectible insurance.

8. HIRED AUTO PHYSICAL DAMAGE COVERAGE

SECTION III - PHYSICAL DAMAGE COVERAGE A. Coverage is amended to add:

If hired “autos” are covered “autos” for Liability Coverage and if Comprehensive, Specified Causes of Loss, or Collision are provided under Coverage form for any “auto” you own, then the Physical Damage Coverages provided are extended to “autos” you hire without a driver, subject to the following limits:

The most we will pay for “loss” to any hired “auto” in any one accident is the smallest of:

18. NOTICE OF AND KNOWLEDGE OF OCCURRENCE

SECTION IV - BUSINESS AUTO CONDITIONS A.2.a. Duties In The Event of Accident, Claim, Suit or Loss is amended to add:

The requirement that you must notify us of an "accident" applies only when the "accident" is known to:

- (1) You, if you are an individual;
- (2) A partner, if you are a partnership; or
- (3) An executive officer or insurance manager, if you are a corporation.

19. BLANKET WAIVER OF SUBROGATION

SECTION IV - BUSINESS AUTO CONDITIONS A.5. Transfer Of Rights Of Recovery Against Others To Us is amended to add:

We waive any right of recovery that we may have against any person or organization because of payments we make for "bodily injury" or "property damage" arising out of the use of a covered "auto" when you have waived those rights under a written contract executed prior to any "accident." This waiver applies only to the person or organization designated in the contract.

20. UNINTENTIONAL FAILURE TO DISCLOSE HAZARDS

SECTION IV - BUSINESS AUTO CONDITIONS B.2. Concealment, Misrepresentation Or Fraud is amended to add:

If you inadvertently fail to disclose any hazards or make an unintentional error in any information provided by you, we will not deny coverage under this form because of such failure or error. This provision does not preclude us from collecting any additional premium or exercising our right of cancellation or non-renewal.

21. MENTAL ANGUISH

SECTION V - DEFINITIONS C. is replaced as follows:

"Bodily injury" means bodily injury, sickness or disease sustained by a person including mental anguish or death resulting from any of these.

22. EXTENDED CANCELLATION CONDITION

Condition A., **Cancellation** in the **MASSACHUSETTS MANDATORY ENDORSEMENT** applies except as follows:

If we cancel for any reason other than nonpayment of premium, any notice of cancellation will be sent to you at your last address shown on the Declarations at least 60 days prior to the effective date.

23. GLASS REPAIR - WAIVER OF DEDUCTIBLE

Under the **MASSACHUSETTS MANDATORY ENDORSEMENT, PHYSICAL DAMAGE COVERAGE D. Deductible** is amended as follows:

No deductible applies to glass damage whether the glass is repaired or replaced.

24. DRIVE OTHER CAR COVERAGE FOR SOLE PROPRIETORS, EXECUTIVE OFFICERS OR PARTNERS

A. This section changes only those coverages where a premium is shown in the Declarations.

POLICY NUMBER: CUP-7691Y645-22-47

EFFECTIVE DATE: 11/12/2022

ISSUE DATE: 10/03/2022

LISTING OF FORMS, ENDORSEMENTS AND SCHEDULE NUMBERS

THIS LISTING SHOWS THE NUMBER OF FORMS, SCHEDULES AND ENDORSEMENTS
BY LINE OF BUSINESS

IL T8 01 01 01 FORMS ENDORSEMENTS AND SCHEDULE NUMBERS

UMBRELLA / EXCESS

EU 00 02 09 20 POLICY DECLARATIONS EXCESS FOLLOW-FORM AND UMBRELLA
LIABILITY INSURANCE POLICY
EU 00 03 08 18 SCHEDULE OF UNDERLYING INSURANCE
EU 00 01 07 16 EXCESS FOLLOW-FORM AND UMBRELLA LIABILITY INSURANCE
EU 00 05 07 16 SCHEDULE OF NAMED INSURED
EU 02 34 07 16 AMENDMENT OF COVERAGE - DEFINITIONS
EU 03 46 08 18 NON CUMULATION OF OCCURRENCE LIMIT
EU 01 44 07 16 COVERAGE FOR FINANCIAL INTEREST IN FOREIGN INSURED
ORGANIZATIONS
EU 03 15 08 18 AMENDMENT OF UNDERLYING INSURANCE DEFINITION
EU 00 07 07 16 CAP LOSSES - CERT ACTS TERRORSM AND EXCL
EU 01 30 08 18 ARCHITECT, ENGINEER OR SURVEYOR PROFESSIONAL SERVICES
EXCLUSION - COVERAGE B
EU 01 48 08 18 DAMAGE TO PROPERTY EXCLUSION - COVERAGE A
EU 01 99 07 16 LEAD EXCLUSION - COVERAGES A AND B
EU 02 09 08 18 NUCLEAR ENERGY LIABILITY EXCLUSION (BROAD FORM) -
COVERAGES A AND B
EU 02 90 07 16 WATERCRAFT LIABILITY EXCLUSION - COVERAGE B
EU 03 31 08 18 DISCRIMINATION EXCLUSION - COVERAGE B
EU 04 21 09 21 INTELLECTUAL PROPERTY EXCLUSION - COVERAGE B

INTERLINE ENDORSEMENTS

IL T3 20 05 19 NOTICE OF CANCELLATION OR NONRENEWAL PROVIDED BY US
IL T3 68 01 21 FEDERAL TERRORISM RISK INSURANCE ACT DISCLOSURE
IL T4 00 05 19 DESIG PERSON, ORG-NOTICE PROVIDED BY US

POLICY HOLDER NOTICES

PN U4 37 03 22 NOTICE OF CHANGE IN POLICY TERMS AMENDMENT OF
INTELLECTUAL PROPERTY EXCLUSION

UMBRELLA

3. When we have the duty to defend, we may, at our discretion, investigate and settle any claim or "suit". In all other cases, we may, at our discretion, participate in the investigation, defense and settlement of any claim or "suit" for damages to which this insurance may apply. If we exercise such right to participate, all expenses we incur in doing so will not reduce the applicable limits of insurance.
4. Our duty to defend ends when we have used up the applicable limit of insurance in the payment of judgments or settlements, or defense expenses if such expenses are within the limits of insurance of this policy.
5. We will pay, with respect to a claim we investigate or settle, or "suit" against an insured we defend:
 - a. All expenses we incur.
 - b. The cost of:
 - (1) Bail bonds required because of accidents or traffic law violations arising out of the use of any vehicle to which this insurance applies; or
 - (2) Appeal bonds and bonds to release attachments;
but only for bond amounts within the applicable limit of insurance. We do not have to furnish these bonds.
 - c. All reasonable expenses incurred by the insured at our request to assist us in the investigation or defense of such claim or "suit", including actual loss of earnings up to \$1,000 a day because of time off from work.
 - d. All court costs taxed against the insured in the "suit". However, these payments do not include attorneys' fees or attorneys' expenses taxed against the insured.
 - e. Prejudgment interest awarded against the insured on that part of the judgment we pay. If we make an offer to pay the applicable limit of insurance, we will not pay any prejudgment interest based on that period of time after the offer.
 - f. All interest that accrues on the full amount of any judgment after entry of the judgment and before we have paid, offered to pay or deposited in court the part of the judgment that is within the applicable limit of insurance. If we do not pay part of the judgment for any reason other than it is more than the applicable limit of insurance, we will not pay any interest that accrues on that portion of the judgment.

With respect to a claim we investigate or settle, or "suit" against an insured we defend under **COVERAGE A – EXCESS FOLLOW-FORM LIABILITY**, these payments will not reduce the applicable limits of insurance, but only if the applicable "underlying insurance" provides for such payments in addition to its limits of insurance. With respect to a claim we investigate or settle, or "suit" against an insured we defend under **COVERAGE B – UMBRELLA LIABILITY**, these payments will not reduce the applicable limits of insurance.

SECTION II – WHO IS AN INSURED

A. COVERAGE A – EXCESS FOLLOW-FORM LIABILITY

With respect to Coverage A, the following persons and organizations qualify as insureds:

1. The Named Insured shown in the Declarations; and
2. Any other person or organization qualifying as an insured in the "underlying insurance". If you have agreed to provide insurance for that person or organization in a written contract or agreement:
 - a. The limits of insurance afforded to such person or organization will be:
 - (1) The amount by which the minimum limits of insurance you agreed to provide such person or organization in that written contract or agreement exceed the total limits of insurance of all applicable "underlying insurance"; or
 - (2) The limits of insurance of this policy; whichever is less; and
 - b. Coverage under this policy does not apply to such person or organization if the minimum limits of insurance you agreed to provide such person or organization in that written contract or agreement are wholly within the total limits of insurance of all available applicable "underlying insurance".

B. COVERAGE B – UMBRELLA LIABILITY

With respect to Coverage B:

1. The Named Insured shown in the Declarations is an insured.
2. If you are:
 - a. An individual, your spouse is also an insured, but only with respect to the conduct of a business of which you are the sole owner.

management event" after the date you acquired or formed such organization.

SECTION V – CONDITIONS

A. APPEALS

1. If the insured or the insured's "underlying insurer" elects not to appeal a judgment which exceeds the "applicable underlying limit" or "self-insured retention", we may do so.
2. If we appeal such a judgment, we will pay all costs of the appeal. These payments will not reduce the applicable limits of insurance. In no event will our liability exceed the applicable limit of insurance.

B. BANKRUPTCY

1. Bankruptcy or insolvency of the insured or of the insured's estate will not relieve us of our obligations under this insurance.
2. In the event of bankruptcy or insolvency of any "underlying insurer", this insurance will not replace such bankrupt or insolvent "underlying insurer's" policy, and this insurance will apply as if such "underlying insurer" had not become bankrupt or insolvent.

C. CANCELLATION

1. The first Named Insured shown in the Declarations may cancel this insurance by mailing or delivering to us advance written notice of cancellation.
2. We may cancel this insurance by mailing or delivering to such first Named Insured written notice of cancellation at least:
 - a. 10 days before the effective date of cancellation if we cancel for nonpayment of premium; or
 - b. 60 days before the effective date of cancellation if we cancel for any other reason.
3. We will mail or deliver our notice to such first Named Insured's last mailing address known to us.
4. Notice of cancellation will state the effective date of cancellation. The policy period will end on that date.
5. If this insurance is cancelled, we will send such first Named Insured any premium refund due. If we cancel, the refund will be pro rata. If such first Named Insured cancels, the refund may be less than pro rata. The cancellation will be effective even if we have not made or offered a refund.
6. If notice is mailed, proof of mailing will be sufficient proof of notice.

D. CHANGES

This policy contains all the agreements between you and us concerning the insurance afforded. No change can be made in the terms of this insurance except with our consent. The terms of this insurance can be amended or waived only by endorsement issued by us and made a part of this policy.

E. CURRENCY

Payments for damages or expenses described in Paragraph 5. of Paragraph D., **DEFENSE AND SUPPLEMENTARY PAYMENTS, of SECTION I – COVERAGES** will be in the currency of the United States of America. At our sole option, we may make these payments in a different currency. Any necessary currency conversion for such payments will be calculated based on the rate of exchange published in the Wall Street Journal immediately preceding the date the payment is processed.

F. DUTIES REGARDING AN EVENT, OCCURRENCE, CLAIM OR SUIT

1. You must see to it that we are notified as soon as practicable of an "event" or "occurrence" which may result in a claim under this insurance. To the extent possible, notice should include:
 - a. How, when and where the "event" or "occurrence" took place;
 - b. The names and addresses of any persons or organizations sustaining injury, damage or loss, and the names and addresses of any witnesses; and
 - c. The nature and location of any injury or damage arising out of the "event" or "occurrence".
2. If a claim is made or "suit" is brought against any insured which may result in a claim under this insurance, you must see to it that we receive written notice of the claim or "suit" as soon as practicable.
3. With respect to Coverage A, the insured must:
 - a. Cooperate with us in the investigation, settlement or defense of any claim or "suit";
 - b. Comply with the terms of the "underlying insurance"; and
 - c. Pursue all rights of contribution or indemnity against any person or organization who may be liable to the insured because of the injury, damage or loss for which insurance is provided under

UMBRELLA

- d. That Extended Reporting Period endorsement is issued by us and made a part of this policy.
3. Any Extended Reporting Period endorsement for this insurance will not reinstate or increase the Limits of Insurance or extend the policy period.
4. Except with respect to any provisions to the contrary contained in Paragraphs 1., 2. or 3. above, all provisions of any option to purchase an "extended reporting period" granted to you in the "underlying insurance" apply to this insurance.

J. INSPECTIONS AND SURVEYS

1. We have the right but are not obligated to:
 - a. Make inspections and surveys at any time;
 - b. Give you reports on the conditions we find; and
 - c. Recommend changes.
2. Any inspections, surveys, reports or recommendations relate only to insurability and the premiums to be charged. We do not make safety inspections. We do not undertake to perform the duty of any person or organization to provide for the health or safety of workers or the public. We do not warrant that conditions:
 - a. Are safe or healthful; or
 - b. Comply with laws, regulations, codes or standards.

K. LEGAL ACTION AGAINST US

1. No person or organization has a right under this insurance:
 - a. To join us as a party or otherwise bring us into a "suit" asking for damages from an insured; or
 - b. To sue us on this insurance unless all of its terms have been fully complied with.
2. A person or organization may sue us to recover on an agreed settlement or on a final judgment against an insured. We will not be liable for damages that:
 - a. Are not payable under the terms of this insurance; or
 - b. Are in excess of the applicable limit of insurance.

An agreed settlement means a settlement and release of liability signed by us, the insured and the claimant or the claimant's legal representative.

L. MAINTENANCE OF UNDERLYING INSURANCE

1. The insurance afforded by each policy of "underlying insurance" will be maintained for

the full policy period of this Excess Follow-Form And Umbrella Liability Insurance. This provision does not apply to the reduction or exhaustion of the aggregate limit or limits of such "underlying insurance" solely by payments as permitted in Paragraphs 4.a.(1), (2) and (3) of **COVERAGE A – EXCESS FOLLOW-FORM LIABILITY** of **SECTION I – COVERAGES**. As such policies expire, you will renew them at limits and with coverage at least equal to the expiring limits of insurance. If you fail to comply with the above requirements, Coverage A is not invalidated. However, in the event of a loss, we will pay only to the extent that we would have paid had you complied with the above requirements.

2. The first Named Insured shown in the Declarations must give us written notice of any change in the "underlying insurance" as respects:
 - a. Coverage;
 - b. Limits of insurance;
 - c. Termination of any coverage; or
 - d. Exhaustion of aggregate limits.
3. If you are unable to recover from any "underlying insurer" because you fail to comply with any term or condition of the "underlying insurance", Coverage A is not invalidated. However, we will pay for any loss only to the extent that we would have paid had you complied with that term or condition in that "underlying insurance".

M. OTHER INSURANCE

This insurance is excess over any valid and collectible "other insurance" whether such "other insurance" is stated to be primary, contributing, excess, contingent or otherwise. This provision does not apply to a policy bought specifically to apply as excess of this insurance.

However, if you specifically agree in a written contract or agreement that the insurance provided to any person or organization that qualifies as an insured under this insurance must apply on a primary basis, or a primary and non-contributory basis, then insurance provided under Coverage A is subject to the following provisions:

1. This insurance will apply before any "other insurance" that is available to such additional insured which covers that person or organization as a named insured, and we will not share with that "other insurance", provided that the injury or damage for which coverage is sought is caused by an "event" that takes place or is committed subsequent to the signing of that contract or agreement by you.
2. This insurance is still excess over any valid and collectible "other insurance", whether primary, excess, contingent or otherwise, which covers that person or organization as an additional insured or as any other insured that does not qualify as a named insured.

N. PREMIUM

1. The first Named Insured shown in the Declarations is responsible for the payment of all premiums and will be the payee for any return premiums.
2. If the premium is a flat charge, it is not subject to adjustment except as provided in Paragraph 4. below.
3. If the premium is other than a flat charge, it is an advance premium only. The earned premium will be computed at the end of the policy period, or at the end of each year of the policy period if the policy period is two years or longer, at the rate shown in the Declarations, subject to the Minimum Premium.
4. Additional premium may become payable when coverage is provided for additional insureds under the provisions of **SECTION II – WHO IS AN INSURED.**

O. PREMIUM AUDIT

The premium for this policy is the amount stated in Item 5. of the Declarations. The premium is a flat charge unless it is specified in the Declarations as adjustable.

P. PROHIBITED COVERAGE – UNLICENSED INSURANCE

1. With respect to loss sustained by any insured in a country or jurisdiction in which we are not licensed to provide this insurance, this insurance does not apply to the extent that insuring such loss would violate the laws or regulations of such country or jurisdiction.
2. We do not assume responsibility for:
 - a. The payment of any fine, fee, penalty or other charge that may be imposed on any person or organization in any country or jurisdiction because we are not licensed to

provide insurance in such country or jurisdiction; or

- b. The furnishing of certificates or other evidence of insurance in any country or jurisdiction in which we are not licensed to provide insurance.

Q. PROHIBITED COVERAGE – TRADE OR ECONOMIC SANCTIONS

We will provide coverage for any loss, or otherwise will provide any benefit, only to the extent that providing such coverage or benefit does not expose us or any of our affiliated or parent companies to:

1. Any trade or economic sanction under any law or regulation of the United States of America; or
2. Any other applicable trade or economic sanction, prohibition or restriction.

R. REPRESENTATIONS

By accepting this insurance, you agree:

1. The statements in the Declarations and any subsequent notice relating to "underlying insurance" are accurate and complete;
2. Those statements are based upon representations you made to us; and
3. We have issued this insurance in reliance upon your representations.

S. SEPARATION OF INSURED

Except with respect to the Limits of Insurance, and any rights or duties specifically assigned in this policy to the first Named Insured shown in the Declarations, this insurance applies:

1. As if each Named Insured were the only Named Insured; and
2. Separately to each insured against whom claim is made or "suit" is brought.

T. WAIVER OR TRANSFER OF RIGHTS OF RECOVERY AGAINST OTHERS TO US

1. If the insured has rights to recover all or part of any payment we have made under this insurance, those rights are transferred to us and the insured must do nothing after loss to impair them. At our request, the insured will bring suit or transfer those rights to us and help us, and with respect to Coverage A, the "underlying insurer", enforce them.

If the insured has agreed in a contract or agreement to waive that insured's right of recovery against any person or organization, we waive our right of recovery against that person or organization, but only for payments we make because of an "event" that takes place or is committed subsequent to the

execution of that contract or agreement by such insured.

2. Reimbursement of any amount recovered will be made in the following order:
 - a. First, to any person or organization (including us or the insured) who has paid any amount in excess of the applicable limit of insurance;
 - b. Next, to us; and
 - c. Then, to any person or organization (including the insured and with respect to Coverage A, the "underlying insurer") that is entitled to claim the remainder, if any.
3. Expenses incurred in the process of recovery will be divided among all persons or organizations receiving amounts recovered according to the ratio of their respective recoveries.

U. TRANSFER OF YOUR RIGHTS AND DUTIES UNDER THIS INSURANCE

1. Your rights and duties under this insurance may not be transferred without our written consent except in the case of death of an individual Named Insured.
2. If you die, your rights and duties will be transferred to your legal representative but only while acting within the scope of duties as your legal representative. Until your legal representative is appointed, anyone having proper temporary custody of your property will have your rights and duties but only with respect to that property.

V. UNINTENTIONAL OMISSION OR ERROR

The unintentional omission of, or unintentional error in, any information provided by you which we relied upon in issuing this policy will not prejudice your rights under this insurance. However, this provision does not affect our right to collect additional premium or to exercise our rights of cancellation or nonrenewal in accordance with applicable insurance laws or regulations.

W. WHEN LOSS IS PAYABLE

If we are liable under this insurance, we will pay for injury, damage or loss after:

1. The insured's liability is established by:
 - a. A court decision; or
 - b. A written agreement between the claimant, the insured, any "underlying insurer" and us; and
2. The amount of the "applicable underlying limit" or "self-insured retention" is paid by or on behalf of the insured.

SECTION VI – DEFINITIONS

A. With respect to all coverages of this insurance:

1. "Applicable underlying limit" means the sum of:
 - a. The applicable limit of insurance stated for the policies of "underlying insurance" in the Schedule Of Underlying Insurance subject to the provisions in Paragraphs 4.a.(1), (2) and (3) of **COVERAGE A – EXCESS FOLLOW-FORM LIABILITY of SECTION I – COVERAGES**; and
 - b. The applicable limit of insurance of any "other insurance" that applies.

The limits of insurance in any policy of "underlying insurance" will apply even if:

- a. The "underlying insurer" claims the insured failed to comply with any term or condition of the policy; or
 - b. The "underlying insurer" becomes bankrupt or insolvent.
2. "Auto hazard" means all "bodily injury" and "property damage" to which liability insurance afforded under an auto policy of "underlying insurance" would apply but for the exhaustion of its applicable limits of insurance.
 3. "Electronic data" means information, facts or programs stored as or on, created or used on, or transmitted to or from computer software (including systems and applications software), hard or floppy disks, CD-ROMs, tapes, drives, cells, data processing devices or any other media which are used with electronically controlled equipment.
 4. "Event" means an "occurrence", offense, accident, act, error, omission, wrongful act or loss.
 5. "Extended reporting period" means any period of time, starting with the end of the policy period of your claims-made insurance, during which claims or "suits" may be first made, brought or reported for that insurance.
 6. "Medical expenses" means expenses to which any Medical Payments section of any policy of Commercial General Liability "underlying insurance" applies.
 7. "Other insurance" means insurance, or the funding of losses, that is provided by, through or on behalf of:
 - a. Another insurance company;
 - b. Us or any of our affiliated insurance companies;
 - c. Any risk retention group;

THIS ENDORSEMENT CHANGES THE POLICY. PLEASE READ IT CAREFULLY.

DESIGNATED PERSON OR ORGANIZATION – NOTICE OF CANCELLATION OR NONRENEWAL PROVIDED BY US

This endorsement modifies insurance provided under the following:

ALL COVERAGE PARTS INCLUDED IN THIS POLICY

SCHEDULE

CANCELLATION:	Number of Days Notice:	<u>30</u>
WHEN WE DO NOT RENEW (Nonrenewal):	Number of Days Notice:	<u>30</u>

PERSON OR ORGANIZATION:

ANY PERSON OR ORGANIZATION TO WHOM YOU HAVE AGREED IN A WRITTEN CONTRACT THAT NOTICE OF CANCELLATION OR NONRENEWAL OF THIS POLICY WILL BE GIVEN, BUT ONLY IF:

1. YOU SEND US A WRITTEN REQUEST TO PROVIDE SUCH NOTICE, INCLUDING THE NAME AND ADDRESS OF SUCH PERSON OR ORGANIZATION, AFTER THE FIRST NAMED INSURED RECEIVES NOTICE FROM US OF THE CANCELLATION OR NONRENEWAL OF THIS POLICY; AND
2. WE RECEIVE SUCH WRITTEN REQUEST AT LEAST 14 DAYS BEFORE THE BEGINNING OF THE APPLICABLE NUMBER OF DAYS SHOWN IN THIS SCHEDULE.

ADDRESS:

THE ADDRESS FOR THAT PERSON OR ORGANIZATION INCLUDED IN SUCH WRITTEN REQUEST FROM YOU TO US.

PROVISIONS

- | | |
|--|--|
| <p>A. If we cancel this policy for any legally permitted reason other than nonpayment of premium, and a number of days is shown for Cancellation in the Schedule above, we will mail notice of cancellation to the person or organization shown in such Schedule. We will mail such notice to the address shown in the Schedule above at least the number of days shown for Cancellation in such Schedule before the effective date of cancellation.</p> | <p>B. If we do not renew this policy for any legally permitted reason other than nonpayment of premium, and a number of days is shown for When We Do Not Renew (Nonrenewal) in the Schedule above, we will mail notice of nonrenewal to the person or organization shown in such Schedule. We will mail such notice to the address shown in the Schedule above at least the number of days shown for When We Do Not Renew (Nonrenewal) in such Schedule before the effective date of nonrenewal.</p> |
|--|--|



ONE TOWER SQUARE
HARTFORD CT 06183

WORKERS COMPENSATION
AND
EMPLOYERS LIABILITY POLICY
ENDORSEMENT WC 00 00 01 (A)

POLICY NUMBER: UB-8J022197-22-47-G

LISTING OF ENDORSEMENTS
EXTENSION OF INFO PAGE

We agree that the following listed endorsements form a part of this policy on its effective date.

WC 00 00 01 A - 001	INFORMATION PAGE
WC 00 00 01 A - 001	INFORMATION PAGE 2
WC 00 00 01 A - 001	EXTENSION OF INFORMATION PAGE - SCHEDULE
WC 00 00 01 A - 001	ENDORSEMENT LISTING
WC 00 03 10 00 - 001	SOLE PROPRIETORS, PARTNERS, OFFICERS END
WC 00 03 11 A - 001	VOLUNTARY COMP AND EMPLOYERS LIAB COV
WC 00 03 13 00 - 001	WAIVER OF OUR RIGHT TO RECOVER
WC 00 04 14 00 - 001	NOTIFICATION OF CHANGE IN OWNERSHIP ENDT
WC 00 04 22 C - 001	TERRORISM RISK INS PROG REAUTH ACT ENDT
WC 00 04 25 00 - 001	EXPER RATING MOD FACTOR REVISION ENDT
WC 20 03 01 00 - 001	MA LIMITS OF LIABILITY ENDORSEMENT
WC 20 03 02 A - 001	MASSACHUSETTS - ASSESMENT CHARGE
WC 20 03 03 D - 001	MA NOTICE TO POLICYHOLDER ENDORSEMENT
WC 20 04 05 00 - 001	MASSACHUSETTS PREMIUM DUE DATE ENDT
WC 20 06 01 A - 001	MA CANCELLATION ENDORSEMENT



**WORKERS COMPENSATION
AND
EMPLOYERS LIABILITY POLICY**

ENDORSEMENT WC 89 06 14 (00) –

POLICY NUMBER: UB-8J022197-22-47-G

**POLICY INFORMATION PAGE
ENDORSEMENT**

Item 3.D. Endorsement numbers is changed to read:

WC 99 06 47 A

WC 99 06 R3 00

ALL OTHER TERMS AND CONDITIONS OF THIS POLICY REMAIN UNCHANGED.

DATE OF ISSUE: 10-21-22 ST ASSIGN:

POLICY NUMBER: UB-8J022197-22-47-G

WAIVER OF OUR RIGHT TO RECOVER FROM OTHERS ENDORSEMENT

We have the right to recover our payments from anyone liable for an injury covered by this policy. We will not enforce our right against the person or organization named in the Schedule. (This agreement applies only to the extent that you perform work under a written contract that requires you to obtain this agreement from us.)

This agreement shall not operate directly or indirectly to benefit any one not named in the Schedule.

SCHEDULE

DESIGNATED PERSON:

DESIGNATED ORGANIZATION:

ANY PERSON OR ORGANIZATION FOR WHICH THE INSURED HAS AGREED
BY WRITTEN CONTRACT EXECUTED PRIOR TO LOSS TO FURNISH THIS
WAIVER.

POLICY NUMBER: UB-8J022197-22-47-G

**NOTICE OF CANCELLATION
 TO DESIGNATED PERSONS OR ORGANIZATIONS**

The following is added to PART SIX – CONDITIONS :

Notice Of Cancellation To Designated Persons Or Organizations

If we cancel this policy for any reason other than non-payment of premium by you, we will provide notice of such cancellation to each person or organization designated in the Schedule below. We will mail or deliver such notice to each person or organization at its listed address at least the number of days shown for that person or organization before the cancellation is to take effect.

You are responsible for providing us with the information necessary to accurately complete the Schedule below. If we cannot mail or deliver a notice of cancellation to a designated person or organization because the name or address of such designated person or organization provided to us is not accurate or complete, we have no responsibility to mail, deliver or otherwise notify such designated person or organization of the cancellation.

SCHEDULE

Name and Address of Designated Persons or Organizations:	Number of Days Notice
ANY PERSON OR ORGANIZATION TO WHOM YOU HAVE AGREED IN A WRITTEN CONTRACT THAT NOTICE OF CANCELLATION OF THIS POLICY WILL BE GIVEN, BUT ONLY IF:	30
1. YOU SEND US A WRITTEN REQUEST TO PROVIDE SUCH NOTICE, INCLUDING THE NAME AND ADDRESS OF SUCH PERSON OR ORGANIZATION , AFTER THE FIRST NAMED INSURED RECEIVES NOTICE FROM US OF THE CANCELLATION OF THIS POLICY; AND	
2. WE RECEIVE SUCH WRITTEN REQUEST AT LEAST 14 DAYS BEFORE THE BEGINNING OF THE APPLICABLE NUMBER OF DAYS SHOWN IN THIS ENDORSEMENT.	

ADDRESS
 THE ADDRESS FOR THAT PERSON OR ORGANIZATION INCLUDED IN SUCH WRITTEN REQUEST FROM YOU TO US.

All other terms and conditions of this policy remain unchanged.

This endorsement changes the policy to which it is attached and is effective on the date issued unless otherwise stated.

(The information below is required only when this endorsement is issued subsequent to preparation of the policy.)

Endorsement Effective Insured

Policy No.

Endorsement No. Premium \$

Insurance Company

Countersigned by _____

APPENDIX A

STANDARD CLAUSES FOR NEW YORK STATE CONTRACTS

**PLEASE RETAIN THIS DOCUMENT
FOR FUTURE REFERENCE.**

January 2014

TABLE OF CONTENTS

	Page
1. Executory Clause	3
2. Non-Assignment Clause	3
3. Comptroller's Approval	3
4. Workers' Compensation Benefits	3
5. Non-Discrimination Requirements	3
6. Wage and Hours Provisions	3
7. Non-Collusive Bidding Certification	4
8. International Boycott Prohibition	4
9. Set-Off Rights	4
10. Records	4
11. Identifying Information and Privacy Notification	4
12. Equal Employment Opportunities For Minorities and Women	4-5
13. Conflicting Terms	5
14. Governing Law	5
15. Late Payment	5
16. No Arbitration	5
17. Service of Process	5
18. Prohibition on Purchase of Tropical Hardwoods	5-6
19. MacBride Fair Employment Principles	6
20. Omnibus Procurement Act of 1992	6
21. Reciprocity and Sanctions Provisions	6
22. Compliance with New York State Information Security Breach and Notification Act	6
23. Compliance with Consultant Disclosure Law	6
24. Procurement Lobbying	7
25. Certification of Registration to Collect Sales and Compensating Use Tax by Certain State Contractors, Affiliates and Subcontractors	7
26. Iran Divestment Act	7

STANDARD CLAUSES FOR NYS CONTRACTS

The parties to the attached contract, license, lease, amendment or other agreement of any kind (hereinafter, "the contract" or "this contract") agree to be bound by the following clauses which are hereby made a part of the contract (the word "Contractor" herein refers to any party other than the State, whether a contractor, licensor, licensee, lessor, lessee or any other party):

1. EXECUTORY CLAUSE. In accordance with Section 41 of the State Finance Law, the State shall have no liability under this contract to the Contractor or to anyone else beyond funds appropriated and available for this contract.

2. NON-ASSIGNMENT CLAUSE. In accordance with Section 138 of the State Finance Law, this contract may not be assigned by the Contractor or its right, title or interest therein assigned, transferred, conveyed, sublet or otherwise disposed of without the State's previous written consent, and attempts to do so are null and void. Notwithstanding the foregoing, such prior written consent of an assignment of a contract let pursuant to Article XI of the State Finance Law may be waived at the discretion of the contracting agency and with the concurrence of the State Comptroller where the original contract was subject to the State Comptroller's approval, where the assignment is due to a reorganization, merger or consolidation of the Contractor's business entity or enterprise. The State retains its right to approve an assignment and to require that any Contractor demonstrate its responsibility to do business with the State. The Contractor may, however, assign its right to receive payments without the State's prior written consent unless this contract concerns Certificates of Participation pursuant to Article 5-A of the State Finance Law.

3. COMPTROLLER'S APPROVAL. In accordance with Section 112 of the State Finance Law (or, if this contract is with the State University or City University of New York, Section 355 or Section 6218 of the Education Law), if this contract exceeds \$50,000 (or the minimum thresholds agreed to by the Office of the State Comptroller for certain S.U.N.Y. and C.U.N.Y. contracts), or if this is an amendment for any amount to a contract which, as so amended, exceeds said statutory amount, or if, by this contract, the State agrees to give something other than money when the value or reasonably estimated value of such consideration exceeds \$10,000, it shall not be valid, effective or binding upon the State until it has been approved by the State Comptroller and filed in his office. Comptroller's approval of contracts let by the Office of General Services is required when such contracts exceed \$85,000 (State Finance Law Section 163.6-a). However, such pre-approval shall not be required for any contract established as a centralized contract through the Office of General Services or for a purchase order or other transaction issued under such centralized contract.

4. WORKERS' COMPENSATION BENEFITS. In accordance with Section 142 of the State Finance Law, this

contract shall be void and of no force and effect unless the Contractor shall provide and maintain coverage during the life of this contract for the benefit of such employees as are required to be covered by the provisions of the Workers' Compensation Law.

5. NON-DISCRIMINATION REQUIREMENTS. To the extent required by Article 15 of the Executive Law (also known as the Human Rights Law) and all other State and Federal statutory and constitutional non-discrimination provisions, the Contractor will not discriminate against any employee or applicant for employment because of race, creed, color, sex (including gender identity or expression), national origin, sexual orientation, military status, age, disability, predisposing genetic characteristics, marital status or domestic violence victim status. Furthermore, in accordance with Section 220-e of the Labor Law, if this is a contract for the construction, alteration or repair of any public building or public work or for the manufacture, sale or distribution of materials, equipment or supplies, and to the extent that this contract shall be performed within the State of New York, Contractor agrees that neither it nor its subcontractors shall, by reason of race, creed, color, disability, sex, or national origin: (a) discriminate in hiring against any New York State citizen who is qualified and available to perform the work; or (b) discriminate against or intimidate any employee hired for the performance of work under this contract. If this is a building service contract as defined in Section 230 of the Labor Law, then, in accordance with Section 239 thereof, Contractor agrees that neither it nor its subcontractors shall by reason of race, creed, color, national origin, age, sex or disability: (a) discriminate in hiring against any New York State citizen who is qualified and available to perform the work; or (b) discriminate against or intimidate any employee hired for the performance of work under this contract. Contractor is subject to fines of \$50.00 per person per day for any violation of Section 220-e or Section 239 as well as possible termination of this contract and forfeiture of all moneys due hereunder for a second or subsequent violation.

6. WAGE AND HOURS PROVISIONS. If this is a public work contract covered by Article 8 of the Labor Law or a building service contract covered by Article 9 thereof, neither Contractor's employees nor the employees of its subcontractors may be required or permitted to work more than the number of hours or days stated in said statutes, except as otherwise provided in the Labor Law and as set forth in prevailing wage and supplement schedules issued by the State Labor Department. Furthermore, Contractor and its subcontractors must pay at least the prevailing wage rate and pay or provide the prevailing supplements, including the premium rates for overtime pay, as determined by the State Labor Department in accordance with the Labor Law. Additionally, effective April 28, 2008, if this is a public work contract covered by Article 8 of the Labor Law, the Contractor understands and agrees that the filing of payrolls in a manner consistent with Subdivision 3-a of Section 220 of the Labor Law shall be a condition precedent to payment by the State of

any State approved sums due and owing for work done upon the project.

7. NON-COLLUSIVE BIDDING CERTIFICATION. In accordance with Section 139-d of the State Finance Law, if this contract was awarded based upon the submission of bids, Contractor affirms, under penalty of perjury, that its bid was arrived at independently and without collusion aimed at restricting competition. Contractor further affirms that, at the time Contractor submitted its bid, an authorized and responsible person executed and delivered to the State a non-collusive bidding certification on Contractor's behalf.

8. INTERNATIONAL BOYCOTT PROHIBITION. In accordance with Section 220-f of the Labor Law and Section 139-h of the State Finance Law, if this contract exceeds \$5,000, the Contractor agrees, as a material condition of the contract, that neither the Contractor nor any substantially owned or affiliated person, firm, partnership or corporation has participated, is participating, or shall participate in an international boycott in violation of the federal Export Administration Act of 1979 (50 USC App. Sections 2401 et seq.) or regulations thereunder. If such Contractor, or any of the aforesaid affiliates of Contractor, is convicted or is otherwise found to have violated said laws or regulations upon the final determination of the United States Commerce Department or any other appropriate agency of the United States subsequent to the contract's execution, such contract, amendment or modification thereto shall be rendered forfeit and void. The Contractor shall so notify the State Comptroller within five (5) business days of such conviction, determination or disposition of appeal (2NYCRR 105.4).

9. SET-OFF RIGHTS. The State shall have all of its common law, equitable and statutory rights of set-off. These rights shall include, but not be limited to, the State's option to withhold for the purposes of set-off any moneys due to the Contractor under this contract up to any amounts due and owing to the State with regard to this contract, any other contract with any State department or agency, including any contract for a term commencing prior to the term of this contract, plus any amounts due and owing to the State for any other reason including, without limitation, tax delinquencies, fee delinquencies or monetary penalties relative thereto. The State shall exercise its set-off rights in accordance with normal State practices including, in cases of set-off pursuant to an audit, the finalization of such audit by the State agency, its representatives, or the State Comptroller.

10. RECORDS. The Contractor shall establish and maintain complete and accurate books, records, documents, accounts and other evidence directly pertinent to performance under this contract (hereinafter, collectively, "the Records"). The Records must be kept for the balance of the calendar year in which they were made and for six (6) additional years thereafter. The State Comptroller, the Attorney General and any other person or entity authorized to conduct an examination, as well as the agency or agencies involved in this

contract, shall have access to the Records during normal business hours at an office of the Contractor within the State of New York or, if no such office is available, at a mutually agreeable and reasonable venue within the State, for the term specified above for the purposes of inspection, auditing and copying. The State shall take reasonable steps to protect from public disclosure any of the Records which are exempt from disclosure under Section 87 of the Public Officers Law (the "Statute") provided that: (i) the Contractor shall timely inform an appropriate State official, in writing, that said records should not be disclosed; and (ii) said records shall be sufficiently identified; and (iii) designation of said records as exempt under the Statute is reasonable. Nothing contained herein shall diminish, or in any way adversely affect, the State's right to discovery in any pending or future litigation.

11. IDENTIFYING INFORMATION AND PRIVACY NOTIFICATION. (a) Identification Number(s). Every invoice or New York State Claim for Payment submitted to a New York State agency by a payee, for payment for the sale of goods or services or for transactions (e.g., leases, easements, licenses, etc.) related to real or personal property must include the payee's identification number. The number is any or all of the following: (i) the payee's Federal employer identification number, (ii) the payee's Federal social security number, and/or (iii) the payee's Vendor Identification Number assigned by the Statewide Financial System. Failure to include such number or numbers may delay payment. Where the payee does not have such number or numbers, the payee, on its invoice or Claim for Payment, must give the reason or reasons why the payee does not have such number or numbers.

(b) Privacy Notification. (1) The authority to request the above personal information from a seller of goods or services or a lessor of real or personal property, and the authority to maintain such information, is found in Section 5 of the State Tax Law. Disclosure of this information by the seller or lessor to the State is mandatory. The principal purpose for which the information is collected is to enable the State to identify individuals, businesses and others who have been delinquent in filing tax returns or may have understated their tax liabilities and to generally identify persons affected by the taxes administered by the Commissioner of Taxation and Finance. The information will be used for tax administration purposes and for any other purpose authorized by law. (2) The personal information is requested by the purchasing unit of the agency contracting to purchase the goods or services or lease the real or personal property covered by this contract or lease. The information is maintained in the Statewide Financial System by the Vendor Management Unit within the Bureau of State Expenditures, Office of the State Comptroller, 110 State Street, Albany, New York 12236.

12. EQUAL EMPLOYMENT OPPORTUNITIES FOR MINORITIES AND WOMEN. In accordance with Section 312 of the Executive Law and 5 NYCRR 143, if this contract is: (i) a written agreement or purchase order instrument, providing for a total expenditure in excess of \$25,000.00,

whereby a contracting agency is committed to expend or does expend funds in return for labor, services, supplies, equipment, materials or any combination of the foregoing, to be performed for, or rendered or furnished to the contracting agency; or (ii) a written agreement in excess of \$100,000.00 whereby a contracting agency is committed to expend or does expend funds for the acquisition, construction, demolition, replacement, major repair or renovation of real property and improvements thereon; or (iii) a written agreement in excess of \$100,000.00 whereby the owner of a State assisted housing project is committed to expend or does expend funds for the acquisition, construction, demolition, replacement, major repair or renovation of real property and improvements thereon for such project, then the following shall apply and by signing this agreement the Contractor certifies and affirms that it is Contractor's equal employment opportunity policy that:

(a) The Contractor will not discriminate against employees or applicants for employment because of race, creed, color, national origin, sex, age, disability or marital status, shall make and document its conscientious and active efforts to employ and utilize minority group members and women in its work force on State contracts and will undertake or continue existing programs of affirmative action to ensure that minority group members and women are afforded equal employment opportunities without discrimination. Affirmative action shall mean recruitment, employment, job assignment, promotion, upgradings, demotion, transfer, layoff, or termination and rates of pay or other forms of compensation;

(b) at the request of the contracting agency, the Contractor shall request each employment agency, labor union, or authorized representative of workers with which it has a collective bargaining or other agreement or understanding, to furnish a written statement that such employment agency, labor union or representative will not discriminate on the basis of race, creed, color, national origin, sex, age, disability or marital status and that such union or representative will affirmatively cooperate in the implementation of the Contractor's obligations herein; and

(c) the Contractor shall state, in all solicitations or advertisements for employees, that, in the performance of the State contract, all qualified applicants will be afforded equal employment opportunities without discrimination because of race, creed, color, national origin, sex, age, disability or marital status.

Contractor will include the provisions of "a", "b", and "c" above, in every subcontract over \$25,000.00 for the construction, demolition, replacement, major repair, renovation, planning or design of real property and improvements thereon (the "Work") except where the Work is for the beneficial use of the Contractor. Section 312 does not apply to: (i) work, goods or services unrelated to this contract; or (ii) employment outside New York State. The State shall consider compliance by a contractor or subcontractor with the requirements of any federal law concerning equal employment

opportunity which effectuates the purpose of this section. The contracting agency shall determine whether the imposition of the requirements of the provisions hereof duplicate or conflict with any such federal law and if such duplication or conflict exists, the contracting agency shall waive the applicability of Section 312 to the extent of such duplication or conflict. Contractor will comply with all duly promulgated and lawful rules and regulations of the Department of Economic Development's Division of Minority and Women's Business Development pertaining hereto.

13. CONFLICTING TERMS. In the event of a conflict between the terms of the contract (including any and all attachments thereto and amendments thereof) and the terms of this Appendix A, the terms of this Appendix A shall control.

14. GOVERNING LAW. This contract shall be governed by the laws of the State of New York except where the Federal supremacy clause requires otherwise.

15. LATE PAYMENT. Timeliness of payment and any interest to be paid to Contractor for late payment shall be governed by Article 11-A of the State Finance Law to the extent required by law.

16. NO ARBITRATION. Disputes involving this contract, including the breach or alleged breach thereof, may not be submitted to binding arbitration (except where statutorily authorized), but must, instead, be heard in a court of competent jurisdiction of the State of New York.

17. SERVICE OF PROCESS. In addition to the methods of service allowed by the State Civil Practice Law & Rules ("CPLR"), Contractor hereby consents to service of process upon it by registered or certified mail, return receipt requested. Service hereunder shall be complete upon Contractor's actual receipt of process or upon the State's receipt of the return thereof by the United States Postal Service as refused or undeliverable. Contractor must promptly notify the State, in writing, of each and every change of address to which service of process can be made. Service by the State to the last known address shall be sufficient. Contractor will have thirty (30) calendar days after service hereunder is complete in which to respond.

18. PROHIBITION ON PURCHASE OF TROPICAL HARDWOODS. The Contractor certifies and warrants that all wood products to be used under this contract award will be in accordance with, but not limited to, the specifications and provisions of Section 165 of the State Finance Law, (Use of Tropical Hardwoods) which prohibits purchase and use of tropical hardwoods, unless specifically exempted, by the State or any governmental agency or political subdivision or public benefit corporation. Qualification for an exemption under this law will be the responsibility of the contractor to establish to meet with the approval of the State.

In addition, when any portion of this contract involving the use of woods, whether supply or installation, is to be performed by any subcontractor, the prime Contractor will indicate and certify in the submitted bid proposal that the subcontractor has been informed and is in compliance with specifications and provisions regarding use of tropical hardwoods as detailed in §165 State Finance Law. Any such use must meet with the approval of the State; otherwise, the bid may not be considered responsive. Under bidder certifications, proof of qualification for exemption will be the responsibility of the Contractor to meet with the approval of the State.

19. MACBRIDE FAIR EMPLOYMENT PRINCIPLES.

In accordance with the MacBride Fair Employment Principles (Chapter 807 of the Laws of 1992), the Contractor hereby stipulates that the Contractor either (a) has no business operations in Northern Ireland, or (b) shall take lawful steps in good faith to conduct any business operations in Northern Ireland in accordance with the MacBride Fair Employment Principles (as described in Section 165 of the New York State Finance Law), and shall permit independent monitoring of compliance with such principles.

20. OMNIBUS PROCUREMENT ACT OF 1992. It is the policy of New York State to maximize opportunities for the participation of New York State business enterprises, including minority and women-owned business enterprises as bidders, subcontractors and suppliers on its procurement contracts.

Information on the availability of New York State subcontractors and suppliers is available from:

NYS Department of Economic Development
Division for Small Business
Albany, New York 12245
Telephone: 518-292-5100
Fax: 518-292-5884
email: opa@esd.ny.gov

A directory of certified minority and women-owned business enterprises is available from:

NYS Department of Economic Development
Division of Minority and Women's Business Development
633 Third Avenue
New York, NY 10017
212-803-2414
email: mwbecertification@esd.ny.gov
<https://ny.newnvccontracts.com/FrontEnd/VendorSearchPublic.asp>

The Omnibus Procurement Act of 1992 requires that by signing this bid proposal or contract, as applicable, Contractors certify that whenever the total bid amount is greater than \$1 million:

(a) The Contractor has made reasonable efforts to encourage the participation of New York State Business Enterprises as suppliers and subcontractors, including certified minority and women-owned business enterprises, on this project, and has retained the documentation of these efforts to be provided upon request to the State;

(b) The Contractor has complied with the Federal Equal Opportunity Act of 1972 (P.L. 92-261), as amended;

(c) The Contractor agrees to make reasonable efforts to provide notification to New York State residents of employment opportunities on this project through listing any such positions with the Job Service Division of the New York State Department of Labor, or providing such notification in such manner as is consistent with existing collective bargaining contracts or agreements. The Contractor agrees to document these efforts and to provide said documentation to the State upon request; and

(d) The Contractor acknowledges notice that the State may seek to obtain offset credits from foreign countries as a result of this contract and agrees to cooperate with the State in these efforts.

21. RECIPROCITY AND SANCTIONS PROVISIONS.

Bidders are hereby notified that if their principal place of business is located in a country, nation, province, state or political subdivision that penalizes New York State vendors, and if the goods or services they offer will be substantially produced or performed outside New York State, the Omnibus Procurement Act 1994 and 2000 amendments (Chapter 684 and Chapter 383, respectively) require that they be denied contracts which they would otherwise obtain. NOTE: As of May 15, 2002, the list of discriminatory jurisdictions subject to this provision includes the states of South Carolina, Alaska, West Virginia, Wyoming, Louisiana and Hawaii. Contact NYS Department of Economic Development for a current list of jurisdictions subject to this provision.

22. COMPLIANCE WITH NEW YORK STATE INFORMATION SECURITY BREACH AND NOTIFICATION ACT. Contractor shall comply with the provisions of the New York State Information Security Breach and Notification Act (General Business Law Section 899-aa; State Technology Law Section 208).

23. COMPLIANCE WITH CONSULTANT DISCLOSURE LAW. If this is a contract for consulting services, defined for purposes of this requirement to include analysis, evaluation, research, training, data processing, computer programming, engineering, environmental, health, and mental health services, accounting, auditing, paralegal, legal or similar services, then, in accordance with Section 163 (4-g) of the State Finance Law (as amended by Chapter 10 of the Laws of 2006), the Contractor shall timely, accurately and properly comply with the requirement to submit an annual employment report for the contract to the agency that awarded

the contract, the Department of Civil Service and the State Comptroller.

24. PROCUREMENT LOBBYING. To the extent this agreement is a "procurement contract" as defined by State Finance Law Sections 139-j and 139-k, by signing this agreement the contractor certifies and affirms that all disclosures made in accordance with State Finance Law Sections 139-j and 139-k are complete, true and accurate. In the event such certification is found to be intentionally false or intentionally incomplete, the State may terminate the agreement by providing written notification to the Contractor in accordance with the terms of the agreement.

25. CERTIFICATION OF REGISTRATION TO COLLECT SALES AND COMPENSATING USE TAX BY CERTAIN STATE CONTRACTORS, AFFILIATES AND SUBCONTRACTORS.

To the extent this agreement is a contract as defined by Tax Law Section 5-a, if the contractor fails to make the certification required by Tax Law Section 5-a or if during the term of the contract, the Department of Taxation and Finance or the covered agency, as defined by Tax Law 5-a, discovers that the certification, made under penalty of perjury, is false, then such failure to file or false certification shall be a material breach of this contract and this contract may be terminated, by providing written notification to the Contractor in accordance with the terms of the agreement, if the covered agency determines that such action is in the best interest of the State.

26. IRAN DIVESTMENT ACT. By entering into this Agreement, Contractor certifies in accordance with State Finance Law §165-a that it is not on the "Entities Determined to be Non-Responsive Bidders/Offerers pursuant to the New York State Iran Divestment Act of 2012" ("Prohibited Entities List") posted at:
<http://www.ogs.ny.gov/about/regs/docs/ListofEntities.pdf>

Contractor further certifies that it will not utilize on this Contract any subcontractor that is identified on the Prohibited Entities List. Contractor agrees that should it seek to renew or extend this Contract, it must provide the same certification at the time the Contract is renewed or extended. Contractor also agrees that any proposed Assignee of this Contract will be required to certify that it is not on the Prohibited Entities List before the contract assignment will be approved by the State.

During the term of the Contract, should the state agency receive information that a person (as defined in State Finance Law §165-a) is in violation of the above-referenced certifications, the state agency will review such information and offer the person an opportunity to respond. If the person fails to demonstrate that it has ceased its engagement in the investment activity which is in violation of the Act within 90 days after the determination of such violation, then the state agency shall take such action as may be appropriate and provided for by law, rule, or contract, including, but not

limited to, imposing sanctions, seeking compliance, recovering damages, or declaring the Contractor in default.

The state agency reserves the right to reject any bid, request for assignment, renewal or extension for an entity that appears on the Prohibited Entities List prior to the award, assignment, renewal or extension of a contract, and to pursue a responsibility review with respect to any entity that is awarded a contract and appears on the Prohibited Entities list after contract award.

APPENDIX B
REQUIREMENTS FOR FEDERALLY-AIDED TRANSPORTATION PROJECTS
(June 2016)

There is a substantial body of requirements attached to the use of Federal highway or transportation aid. These requirements create or overlay processes, procedures, documentation requirements, authorizations, approvals and certifications that may be substantially greater or different from those that are not funded with Federal-aid and proceed under applicable State and local laws, customs and practices. Under Title 23 of the United States Code, the New York State Department of Transportation (NYSDOT) is responsible for the administration of transportation projects in New York State to which NYSDOT provides Federal highway or transportation-related aid. Through this Agreement, which provides or is associated with such funding, NYSDOT delegates various elements of project and funding administration as described elsewhere in this Agreement. In undertaking a Federally aided project, the Municipality/Sponsor, Authority or Project Manager designated under this Agreement with Federal-aid funding or project administration agrees to proceed in compliance with all the applicable Federal-aid requirements.

NYSDOT, in cooperation with FHWA, has assembled the body of Federal-aid requirements, procedures and practices in its Procedures for Locally Administered Federal-Aid Projects Manual (available through NYSDOT's web site at: <http://www.dot.ny.gov/plafap>). In addition, the Municipality/Sponsor, Authority or Project Manager designated under this Agreement for Federal-aid funding or project administration that enters into Federally aided project construction contracts is required to physically incorporate into all its Federally aided construction contracts and subcontracts there under the provisions that are contained in Form FHWA-1273 (available from NYSDOT or electronically at: <http://www.fhwa.dot.gov/programadmin/contracts/1273.htm>).

In addition to the referenced requirements, the attention of Municipality/Sponsor hereunder is directed to the following requirements and information:

NON DISCRIMINATION/EEO/DBE REQUIREMENTS

The Municipality/Sponsor and its contractors agree to comply with Executive Order 11246, entitled "Equal Employment Opportunity" and United States Department of Transportation (USDOT) regulations (49 CFR Parts 21, 23, 25, 26 and 27) and the following:

1. **NON DISCRIMINATION**. No person shall, on the ground of race, color, creed, national origin, sex, age or handicap, be excluded from participation in, or denied the benefits of, or be subject to, discrimination under the Project funded through this Agreement.
2. **EQUAL EMPLOYMENT OPPORTUNITY**. In connection with the execution of this Agreement, the Municipality/Sponsors contractors or subcontractors shall not discriminate against any employee or applicant for employment because of race, religion, age, color, sex or national origin. Such contractors shall take affirmative actions to ensure that applicants are employed, and that employees are treated during their employment, without regard to their race, religion, color, sex, national origin or age. Such actions shall include, but not be limited to, the following: employment, upgrading, demotion or transfer; recruitment or recruitment advertising; layoff or termination; rates of pay or other forms of compensation; and selection for training, including apprenticeship.

3. **DISADVANTAGED BUSINESS ENTERPRISES**. In connection with the performance of this Agreement, the Municipality/Sponsor shall cause its contractors to cooperate with the State in meeting its commitments and goals with regard to the utilization of Disadvantaged Business Enterprises (DBEs) and will use its best efforts to ensure that DBEs will have opportunity to compete for subcontract work under this Agreement. Also, in this connection the Municipality or Municipality/Sponsor shall cause its contractors to undertake such actions as may be necessary to comply with 49 CFR Part 26.

As a sub-recipient under 49 CFR Part 26.13, the Municipality/Sponsor hereby makes the following assurance.

The Municipality/Sponsor shall not discriminate on the basis of race, color, national origin, or sex in the award and performance of any United States Department of Transportation (USDOT)-assisted contract or in the administration of its Disadvantaged Business Enterprise (DBE) program or the requirements of 49 CFR Part 26. The Municipality/Sponsor shall take all necessary and reasonable steps under 49 CFR Part 26 to ensure nondiscrimination in the award and administration of the United States Department of Transportation-assisted contracts. The New York State Department of Transportation's DBE program, as required by 49 CFR Part 26 and as approved by the United States Department of Transportation, is incorporated by reference in this agreement. Implementation of this program is a legal obligation and failure to carry out its terms shall be treated as a violation of this agreement. Upon notification to the recipient of its failure to carry out its approved program, the USDOT may impose sanctions as provided for under part 26 and may, in appropriate cases, refer the matter for enforcement under 18 U.S.C. 1001 and/or the Program Fraud Civil Remedies Act of 1986 (31 U.S.C. 3801 et seq.).

FEDERAL SINGLE AUDIT REQUIREMENTS

Non-Federal entities that expend \$750,000 or more in a year in Federal awards from all sources are required to comply with the Federal Single Audit Act provisions contained in U.S. Office of Management and Budget (OMB) Circular No. A-133, Audits of States, Local Governments, and Non-Profit Organizations. Non-Federal entities that expend Federal awards from a single source may provide a program specific audit, as defined in the Circular. Non-Federal entities that expend less than the amount above in a year in Federal awards from all sources are exempt from Federal audit requirements for that year, except as noted in Sec. 215 (a) of OMB Circular A-133 Subpart B--Audits, records must be available for review or audit by appropriate officials of the cognizant Federal agency¹ the New York State Department of Transportation, the New York State Comptrollers Office and the U.S. Governmental Accountability Office (GAO).

Non-Federal entities are required to submit a copy of all audits, as described above, within 30 days of issuance of audit report, but no later than 9 months after the end of the entity's fiscal year, to the New York State Department of Transportation, Contract Audit Bureau, 50 Wolf Road, Albany, NY 12232. Unless a time extension has been granted by the cognizant Federal Agency and has been filed with the New York State Department of Transportation's Contract Audit Bureau, failure to comply with the requirements of OMB Circular A-133 may result in suspension or termination of Federal award payments.

¹ The designated cognizant agency for audit shall be the federal awarding agency that provides the predominant amount of direct funding to a recipient unless OMB changes it.

THE CATALOG OF FEDERAL DOMESTIC ASSISTANCE

The Catalog of Federal Domestic Assistance (CFDA²), is an on-line database of all Federally-aided programs available to State and local governments (including the District of Columbia); Federally recognized Indian tribal governments; Territories (and possessions) of the United States; domestic public, quasi-public, and private profit and nonprofit organizations and institutions; specialized groups; and individuals.

THE CFDA IDENTIFICATION NUMBER

OMB Circular A-133 requires all Federal-aid recipients to identify and account for awards and expenditures by CFDA Number. The Municipality/Sponsor is required to identify in its accounts all Federal awards received and expended, and the Federal programs under which they were received. Federal program and award identification shall include, as applicable, the CFDA title and number, award number and year, name of the Federal agency, and name of the pass-through entity.

The most commonly used CFDA number for the Federal Aid Highway Planning and Construction program is 20.205.

Additional CFDA numbers for other transportation and non-transportation related programs are:

- 20.215 Highway Training and Education**
- 20.219 Recreational Trails Program**
- 20.XXX Highway Planning and Construction - Highways for LIFE;**
- 20.XXX Surface Transportation Research and Development;**
- 20.500 Federal Transit-Capital Investment Grants**
- 20.505 Federal Transit-Metropolitan Planning Grants**
- 20.507 Federal Transit-Formula Grants**
- 20.509 Formula Grants for Other Than Urbanized Areas**
- 20.600 State and Community Highway Safety**
- 23.003 Appalachian Development Highway System**
- 23.008 Appalachian Local Access Roads.**

PROMPT PAYMENT MECHANISMS

In accordance with 49 CFR 26.29, and NY State Finance Law 139-f or NY General Municipal Law 106-b(2) as applicable:

(a) You must establish, as part of your DBE program, a contract clause to require prime contractors to pay subcontractors for satisfactory performance of their contracts no later than 7 calendar days from receipt of each payment you make to the prime contractor.

(b) You must ensure prompt and full payment of retainage from the prime contractor to the subcontractor within 7 calendar days after the subcontractor's work is satisfactorily completed. You must use one of the following methods to comply with this requirement:

(1) You may decline to hold retainage from prime contractors and prohibit prime contractors from holding retainage from subcontractors.

(2) You may decline to hold retainage from prime contractors and require a contract clause obligating prime contractors to make prompt and full payment of any retainage kept by

² <http://www.cfda.gov/>

prime contractor to the subcontractor within 7 calendar days after the subcontractor's work is satisfactorily completed.

(3) You may hold retainage from prime contractors and provide for prompt and regular incremental acceptances of portions of the prime contract, pay retainage to prime contractors based on these acceptances, and require a contract clause obligating the prime contractor to pay all retainage owed to the subcontractor for satisfactory completion of the accepted work within 7 calendar days after your payment to the prime contractor.

(c) For purposes of this section, a subcontractor's work is satisfactorily completed when all the tasks called for in the subcontract have been accomplished and documented as required by the recipient. When a recipient has made an incremental acceptance of a portion of a prime contract, the work of a subcontractor covered by that acceptance is deemed to be satisfactorily completed.

(d) Your DBE program must provide appropriate means to enforce the requirements of this section. These means may include appropriate penalties for failure to comply, the terms and conditions of which you set. Your program may also provide that any delay or postponement of payment among the parties may take place only for good cause, with your prior written approval.

(e) You may also establish, as part of your DBE program, any of the following additional mechanisms to ensure prompt payment:

(1) A contract clause that requires prime contractors to include in their subcontracts language providing that prime contractors and subcontractors will use appropriate alternative dispute resolution mechanisms to resolve payment disputes. You may specify the nature of such mechanisms.

(2) A contract clause providing that the prime contractor will not be reimbursed for work performed by subcontractors unless and until the prime contractor ensures that the subcontractors are promptly paid for the work they have performed.

(3) Other mechanisms, consistent with this part and applicable state and local law, to ensure that DBEs and other contractors are fully and promptly paid.

CARGO PREFERENCE ACT REQUIREMENTS – U.S. FLAG VESSELS

In accordance with 46 CFR 381, the contractor agrees:

(a) To utilize privately owned United States-flag commercial vessels to ship at least 50 percent of the gross tonnage (computed separately for dry bulk carriers, dry cargo liners, and tankers) involved, whenever shipping any equipment, material, or commodities pursuant to this contract, to the extent such vessels are available at fair and reasonable rates for United States-flag commercial vessels.

(b) To furnish within 20 days following the date of loading for shipments originating within the United States or within 30 working days following the date of loading for shipments originating outside the United States, a legible copy of a rated, 'on-board' commercial ocean bill-of-lading in English for each shipment of cargo described in paragraph (b) (1) of this section to both the Contracting Officer (through the prime contractor in the case of subcontractor bills-of-lading) and to the Division of National Cargo, Office of Market Development, Maritime Administration, Washington, DC 20590.

(c) To insert the substance of the provisions of this clause in all subcontracts issued pursuant to this contract.

CERTIFICATION OF OFFERER/BIDDER REGARDING DEBARMENT

Contractor/Consultant, by entering into this agreement, certifies that neither it nor its principals are presently debarred or suspended by any Federal department or agency from participation in this transaction.

CERTIFICATION OF LOWER TIER CONTRACTORS REGARDING DEBARMENT

The Contractor/Consultant, by administering each lower tier subcontract that exceeds \$25,000 as a "covered transaction", must verify each lower tier participant of a "covered transaction" under the project is not presently debarred or otherwise disqualified from participation in this federally assisted project. The successful bidder will accomplish this by:

1. Checking the System for Award Management at website: <http://www.sam.gov>.
2. Collecting a certification statement similar to the Certification of Offerer/Bidder Regarding Debarment, above.
3. Inserting a clause or condition in the covered transaction with the lower tier contract.

If the Federal Aviation Administration later determines that a lower tier participant failed to disclose to a higher tier participant that it was excluded or disqualified at the time it entered the covered transaction, the FAA may pursue any available remedies, including suspension and debarment of the non-compliant participant.



U.S. Department
of Transportation
**Federal Aviation
Administration**

FAA Form 5100-129, Construction Project Final Acceptance – Airport Improvement Program Sponsor Certification

Paperwork Reduction Act Burden Statement

A federal agency may not conduct or sponsor, and a person is not required to respond to, nor shall a person be subject to a penalty for failure to comply with a collection of information subject to the requirements of the Paperwork Reduction Act unless that collection of information displays a currently valid OMB Control Number. The OMB Control Number for this information collection is 2120-0569. Public reporting for this collection of information is estimated to be approximately 8 hours per response, including the time for reviewing instructions, searching existing data sources, gathering and maintaining the data needed, completing and reviewing the collection of information. All responses to this collection of information are required under 49 U.S.C. Section 47105 to retain a benefit and to meet the reporting requirements of 2 CFR 200. Send comments regarding this burden estimate or any other aspect of this collection of information, including suggestions for reducing this burden to: Information Collection Clearance Officer, Federal Aviation Administration, 10101 Hillwood Parkway, Fort Worth, TX 76177-1524.

Construction Project Final Acceptance Airport Improvement Program Sponsor Certification

Sponsor:

Airport:

Project Number:

Description of Work:

Application

49 USC § 47105(d), authorizes the Secretary to require me certification from the sponsor that it will comply with the statutory and administrative requirements in carrying out a project under the Airport Improvement Program. General standards for final acceptance and close out of federally funded construction projects are in 2 CFR § 200.343 – Closeout and supplemented by FAA Order 5100.38. The sponsor must determine that project costs are accurate and proper in accordance with specific requirements of the grant agreement and contract documents.

Certification Statements

Except for certification statements below marked not applicable (N/A), this list includes major requirements of the construction project. Selecting “Yes” represents sponsor acknowledgment and confirmation of the certification statement. The term “will” means Sponsor action taken at appropriate time based on the certification statement focus area, but no later than the end of the project period of performance. This list is not comprehensive and does not relieve the sponsor from fully complying with all applicable statutory and administrative standards. The source of the requirement is referenced within parenthesis.

1. The personnel engaged in project administration, engineering supervision, project inspection, and acceptance testing were or will be determined to be qualified and competent to perform the work (Grant Assurance).

Yes No N/A

2. Construction records, including daily logs, were or will be kept by the resident engineer/construction inspector that fully document contractor’s performance in complying with:
 - a. Technical standards (Advisory Circular (AC) 150/5370-12);
 - b. Contract requirements (2 CFR part 200 and FAA Order 5100.38); and
 - c. Construction safety and phasing plan measures (AC 150/5370-2).

Yes No N/A

3. All acceptance tests specified in the project specifications were or will be performed and documented. (AC 150/5370-12).

Yes No N/A

4. Sponsor has taken or will take appropriate corrective action for any test result outside of allowable tolerances (AC 150/5370-12).
- Yes No N/A
5. Pay reduction factors required by the specifications were applied or will be applied in computing final payments with a summary made available to the FAA (AC 150/5370-10).
- Yes No N/A
6. Sponsor has notified, or will promptly notify the Federal Aviation Administration (FAA) of the following occurrences:
- a. Violations of any federal requirements set forth or included by reference in the contract documents (2 CFR part 200);
 - b. Disputes or complaints concerning federal labor standards (29 CFR part 5); and
 - c. Violations of or complaints addressing conformance with Equal Employment Opportunity or Disadvantaged Business Enterprise requirements (41 CFR Chapter 60 and 49 CFR part 26).
- Yes No N/A
7. Weekly payroll records and statements of compliance were or will be submitted by the prime contractor and reviewed by the sponsor for conformance with federal labor and civil rights requirements as required by FAA and U.S. Department of Labor (29 CFR Part 5).
- Yes No N/A
8. Payments to the contractor were or will be made in conformance with federal requirements and contract provisions using sponsor internal controls that include:
- a. Retaining source documentation of payments and verifying contractor billing statements against actual performance (2 CFR § 200.302 and FAA Order 5100.38);
 - b. Prompt payment of subcontractors for satisfactory performance of work (49 CFR § 26.29);
 - c. Release of applicable retainage upon satisfactory performance of work (49 CFR § 26.29); and
 - d. Verification that payments to DBEs represent work the DBE performed by carrying out a commercially useful function (49 CFR §26.55).
- Yes No N/A
9. A final project inspection was or will be conducted with representatives of the sponsor and the contractor present that ensure:
- a. Physical completion of project work in conformance with approved plans and specifications (Order 5100.38);
 - b. Necessary actions to correct punch list items identified during final inspection are complete (Order 5100.38); and
 - c. Preparation of a record of final inspection and distribution to parties to the contract (Order 5100.38);
- Yes No N/A
10. The project was or will be accomplished without material deviations, changes, or modifications from approved plans and specifications, except as approved by the FAA (Order 5100.38).
- Yes No N/A

11. The construction of all buildings have complied or will comply with the seismic construction requirements of 49 CFR § 41.120.

Yes No N/A

12. For development projects, sponsor has taken or will take the following close-out actions:

- a. Submit to the FAA a final test and quality assurance report summarizing acceptance test results, as applicable (Grant Condition);
- b. Complete all environmental requirements as established within the project environmental determination (Order 5100.38); and
- c. Prepare and retain as-built plans (Order 5100.38).

Yes No N/A

13. Sponsor has revised or will revise their airport layout plan (ALP) that reflects improvements made and has submitted or will submit an updated ALP to the FAA no later than 90 days from the period of performance end date. (49 USC § 47107 and Order 5100.38).

Yes No N/A

Attach documentation clarifying any above item marked with "No" response.

Sponsor's Certification

I certify, for the project identified herein, responses to the forgoing items are accurate as marked and additional documentation for any item marked "no" is correct and complete.

Executed on this day of , .

Name of Sponsor:

Name of Sponsor's Authorized Official:

Title of Sponsor's Authorized Official:

Signature of Sponsor's Authorized Official: _____

I declare under penalty of perjury that the foregoing is true and correct. I understand that knowingly and willfully providing false information to the federal government is a violation of 18 USC § 1001 (False Statements) and could subject me to fines, imprisonment, or both.



U.S. Department
of Transportation
**Federal Aviation
Administration**

FAA Form 5100-130, Drug-Free Workplace – Airport Improvement Program Sponsor Certification

Paperwork Reduction Act Burden Statement

A federal agency may not conduct or sponsor, and a person is not required to respond to, nor shall a person be subject to a penalty for failure to comply with a collection of information subject to the requirements of the Paperwork Reduction Act unless that collection of information displays a currently valid OMB Control Number. The OMB Control Number for this information collection is 2120-0569. Public reporting for this collection of information is estimated to be approximately 8 hours per response, including the time for reviewing instructions, searching existing data sources, gathering and maintaining the data needed, completing and reviewing the collection of information. All responses to this collection of information are required under 49 U.S.C. Section 47105 to retain a benefit and to meet the reporting requirements of 2 CFR 200. Send comments regarding this burden estimate or any other aspect of this collection of information, including suggestions for reducing this burden to: Information Collection Clearance Officer, Federal Aviation Administration, 10101 Hillwood Parkway, Fort Worth, TX 76177-1524.



Drug-Free Workplace Airport Improvement Program Sponsor Certification

Sponsor:

Airport:

Project Number:

Description of Work:

Application

49 USC § 47105(d) authorizes the Secretary to require certification from the sponsor that it will comply with the statutory and administrative requirements in carrying out a project under the Airport Improvement Program (AIP). General requirements on the drug-free workplace within federal grant programs are described in 2 CFR part 182. Sponsors are required to certify they will be, or will continue to provide, a drug-free workplace in accordance with the regulation. The AIP project grant agreement contains specific assurances on the Drug-Free Workplace Act of 1988.

Certification Statements

Except for certification statements below marked as not applicable (N/A), this list includes major requirements of the construction project. Selecting “Yes” represents sponsor acknowledgement and confirmation of the certification statement. The term “will” means Sponsor action taken at appropriate time based on the certification statement focus area, but no later than the end of the project period of performance. This list is not comprehensive and does not relieve the sponsor from fully complying with all applicable statutory and administrative standards. The source of the requirement is referenced within parenthesis.

1. A statement has been or will be published prior to commencement of project notifying employees that the unlawful manufacture, distribution, dispensing, possession, or use of a controlled substance is prohibited in the sponsor's workplace, and specifying the actions to be taken against employees for violation of such prohibition (2 CFR § 182.205).

Yes No N/A

2. An ongoing drug-free awareness program (2 CFR § 182.215) has been or will be established prior to commencement of project to inform employees about:
 - a. The dangers of drug abuse in the workplace;
 - b. The sponsor's policy of maintaining a drug-free workplace;
 - c. Any available drug counseling, rehabilitation, and employee assistance programs; and
 - d. The penalties that may be imposed upon employees for drug abuse violations occurring in the workplace.

Yes No N/A

3. Each employee to be engaged in the performance of the work has been or will be given a copy of the statement required within item 1 above prior to commencement of project (2 CFR § 182.210).

Yes No N/A

4. Employees have been or will be notified in the statement required by item 1 above that, as a condition employment under the grant (2 CFR § 182.205(c)), the employee will:

- a. Abide by the terms of the statement; and
- b. Notify the employer in writing of his or her conviction for a violation of a criminal drug statute occurring in the workplace no later than five calendar days after such conviction.

Yes No N/A

5. The Federal Aviation Administration (FAA) will be notified in writing within 10 calendar days after receiving notice under item 4b above from an employee or otherwise receiving actual notice of such conviction (2 CFR § 182.225). Employers of convicted employees must provide notice, including position title of the employee, to the FAA (2 CFR § 182.300).

Yes No N/A

6. One of the following actions (2 CFR § 182.225(b)) will be taken within 30 calendar days of receiving a notice under item 4b above with respect to any employee who is so convicted:

- a. Take appropriate personnel action against such an employee, up to and including termination, consistent with the requirements of the Rehabilitation Act of 1973, as amended; and
- b. Require such employee to participate satisfactorily in drug abuse assistance or rehabilitation programs approved for such purposes by a federal, state, or local health, law enforcement, or other appropriate agency.

Yes No N/A

7. A good faith effort will be made, on a continuous basis, to maintain a drug-free workplace through implementation of items 1 through 6 above (2 CFR § 182.200).

Yes No N/A

Site(s) of performance of work (2 CFR § 182.230):

Location 1

Name of Location:

Address:

Location 2 (if applicable)

Name of Location:

Address:

Location 3 (if applicable)

Name of Location:

Address:

Attach documentation clarifying any above item marked with a "No" response.

Sponsor's Certification

I certify, for the project identified herein, responses to the forgoing items are accurate as marked and additional documentation for any item marked "no" is correct and complete.

Executed on this day of , .

Name of Sponsor:

Name of Sponsor's Authorized Official:

Title of Sponsor's Authorized Official:

Signature of Sponsor's Authorized Official: _____

I declare under penalty of perjury that the foregoing is true and correct. I understand that knowingly and willfully providing false information to the federal government is a violation of 18 USC § 1001 (False Statements) and could subject me to fines, imprisonment, or both.



U.S. Department
of Transportation
**Federal Aviation
Administration**

FAA Form 5100-131, Equipment and Construction Contracts – Airport Improvement Sponsor Certification

Paperwork Reduction Act Burden Statement

A federal agency may not conduct or sponsor, and a person is not required to respond to, nor shall a person be subject to a penalty for failure to comply with a collection of information subject to the requirements of the Paperwork Reduction Act unless that collection of information displays a currently valid OMB Control Number. The OMB Control Number for this information collection is 2120-0569. Public reporting for this collection of information is estimated to be approximately 8 hours per response, including the time for reviewing instructions, searching existing data sources, gathering and maintaining the data needed, completing and reviewing the collection of information. All responses to this collection of information are required under 49 U.S.C. Section 47105 to retain a benefit and to meet the reporting requirements of 2 CFR 200. Send comments regarding this burden estimate or any other aspect of this collection of information, including suggestions for reducing this burden to: Information Collection Clearance Officer, Federal Aviation Administration, 10101 Hillwood Parkway, Fort Worth, TX 76177-1524.



Equipment and Construction Contracts Airport Improvement Sponsor Certification

Sponsor:

Airport:

Project Number:

Description of Work:

Application

49 USC § 47105(d) authorizes the Secretary to require certification from the sponsor that it will comply with the statutory and administrative requirements in carrying out a project under the Airport Improvement Program (AIP). General procurement standards for equipment and construction contracts within Federal grant programs are described in 2 CFR §§ 200.317-200.326. Labor and Civil Rights Standards applicable to the AIP are established by the Department of Labor (www.dol.gov) AIP Grant Assurance C.1—General Federal Requirements identifies all applicable Federal Laws, regulations, executive orders, policies, guidelines and requirements for assistance under the AIP. Sponsors may use state and local procedures provided the procurement conforms to these federal standards.

This certification applies to all equipment and construction projects. Equipment projects may or may not employ laborers and mechanics that qualify the project as a “covered contract” under requirements established by the Department of Labor requirements. Sponsor shall provide appropriate responses to the certification statements that reflect the character of the project regardless of whether the contract is for a construction project or an equipment project.

Certification Statements

Except for certification statements below marked as not applicable (N/A), this list includes major requirements of the construction project. Selecting “Yes” represents sponsor acknowledgement and confirmation of the certification statement. The term “will” means Sponsor action taken at appropriate time based on the certification statement focus area, but no later than the end of the project period of performance. This list is not comprehensive and does not relieve the sponsor from fully complying with all applicable statutory and administrative standards. The source of the requirement is referenced within parenthesis.

1. A written code or standard of conduct is or will be in effect prior to commencement of the project that governs the performance of the sponsor’s officers, employees, or agents in soliciting, awarding and administering procurement contracts (2 CFR § 200.318).

Yes	No	N/A
-----	----	-----

2. For all contracts, qualified and competent personnel are or will be engaged to perform contract administration, engineering supervision, construction inspection, and testing (Grant Assurance C.17).

Yes No N/A

3. Sponsors that are required to have a Disadvantage Business Enterprise (DBE) program on file with the FAA have included or will include clauses required by Title VI of the Civil Rights Act and 49 CFR Part 26 for Disadvantaged Business Enterprises in all contracts and subcontracts.

Yes No N/A

4. Sponsors required to have a DBE program on file with the FAA have implemented or will implement monitoring and enforcement measures that:

- a. Ensure work committed to Disadvantaged Business Enterprises at contract award is actually performed by the named DBEs (49 CFR § 26.37(b));
- b. Include written certification that the sponsor has reviewed contract records and has monitored work sites for performance by DBE firms (49 CFR § 26.37(b)); and
- c. Provides for a running tally of payments made to DBE firms and a means for comparing actual attainments (i.e. payments) to original commitments (49 CFR § 26.37(c)).

Yes No N/A

5. Sponsor procurement actions using the competitive sealed bid method (2 CFR § 200.320(c)). was or will be:

- a. Publicly advertised, allowing a sufficient response time to solicit an adequate number of interested contractors or vendors;
- b. Prepared to include a complete, adequate and realistic specification that defines the items or services in sufficient detail to allow prospective bidders to respond;
- c. Publicly opened at a time and place prescribed in the invitation for bids; and
- d. Prepared in a manner that result in a firm fixed price contract award to the lowest responsive and responsible bidder.

Yes No N/A

6. For projects the Sponsor proposes to use the competitive proposal procurement method (2 CFR § 200.320(d)), Sponsor has requested or will request FAA approval prior to proceeding with a competitive proposal procurement by submitting to the FAA the following:

- a. Written justification that supports use of competitive proposal method in lieu of the preferred sealed bid procurement method;
- b. Plan for publicizing and soliciting an adequate number of qualified sources; and
- c. Listing of evaluation factors along with relative importance of the factors.

Yes No N/A

7. For construction and equipment installation projects, the bid solicitation includes or will include the current federal wage rate schedule(s) for the appropriate type of work classifications (2 CFR Part 200, Appendix II).

Yes No N/A

8. Concurrence was or will be obtained from the Federal Aviation Administration (FAA) prior to contract award under any of the following circumstances (Order 5100.38D):

- a. Only one qualified person/firm submits a responsive bid;
- b. Award is to be made to other than the lowest responsible bidder; and
- c. Life cycle costing is a factor in selecting the lowest responsive bidder.

Yes No N/A

9. All construction and equipment installation contracts contain or will contain provisions for:

- a. Access to Records (§ 200.336)
- b. Buy American Preferences (Title 49 U.S.C. § 50101)
- c. Civil Rights - General Provisions and Title VI Assurances(41 CFR part 60)
- d. Federal Fair Labor Standards (29 U.S.C. § 201, et seq)
- e. Occupational Safety and Health Act requirements (20 CFR part 1920)
- f. Seismic Safety – building construction (49 CFR part 41)
- g. State Energy Conservation Requirements - as applicable(2 CFR part 200, Appendix II)
- h. U.S. Trade Restriction (49 CFR part 30)
- i. Veterans Preference (49 USC § 47112(c))

Yes No N/A

10. All construction and equipment installation contracts exceeding \$2,000 contain or will contain the provisions established by:

- a. Davis-Bacon and Related Acts (29 CFR part 5)
- b. Copeland “Anti-Kickback” Act (29 CFR parts 3 and 5)

Yes No N/A

11. All construction and equipment installation contracts exceeding \$3,000 contain or will contain a contract provision that discourages distracted driving (E.O. 13513).

Yes No N/A

12. All contracts exceeding \$10,000 contain or will contain the following provisions as applicable:

- a. Construction and equipment installation projects - Applicable clauses from 41 CFR Part 60 for compliance with Executive Orders 11246 and 11375 on Equal Employment Opportunity;
- b. Construction and equipment installation - Contract Clause prohibiting segregated facilities in accordance with 41 CFR part 60-1.8;
- c. Requirement to maximize use of products containing recovered materials in accordance with 2 CFR § 200.322 and 40 CFR part 247; and
- d. Provisions that address termination for cause and termination for convenience (2 CFR Part 200, Appendix II).

Yes No N/A

13. All contracts and subcontracts exceeding \$25,000: Measures are in place or will be in place (e.g. checking the System for Award Management) that ensure contracts and subcontracts are not awarded to individuals or firms suspended, debarred, or excluded from participating in federally assisted projects (2 CFR parts 180 and 1200).

Yes No N/A

14. Contracts exceeding the simplified acquisition threshold (currently \$250,000) include or will include provisions, as applicable, that address the following:

- a. Construction and equipment installation contracts - a bid guarantee of 5%, a performance bond of 100%, and a payment bond of 100% (2 CFR § 200.325);
- b. Construction and equipment installation contracts - requirements of the Contract Work Hours and Safety Standards Act (40 USC 3701-3708, Sections 103 and 107);
- c. Restrictions on Lobbying and Influencing (2 CFR part 200, Appendix II);
- d. Conditions specifying administrative, contractual and legal remedies for instances where contractor or vendor violate or breach the terms and conditions of the contract (2 CFR §200, Appendix II); and
- e. All Contracts - Applicable standards and requirements issued under Section 306 of the Clean Air Act (42 USC 7401-7671q), Section 508 of the Clean Water Act (33 USC 1251-1387, and Executive Order 11738.

Yes No N/A

Attach documentation clarifying any above item marked with "No" response.

Sponsor's Certification

I certify, for the project identified herein, responses to the forgoing items are accurate as marked and additional documentation for any item marked "no" is correct and complete.

Executed on this day of , .

Name of Sponsor:

Name of Sponsor's Authorized Official:

Title of Sponsor's Authorized Official:

Signature of Sponsor's Authorized Official: _____

I declare under penalty of perjury that the foregoing is true and correct. I understand that knowingly and willfully providing false information to the federal government is a violation of 18 USC § 1001 (False Statements) and could subject me to fines, imprisonment, or both.



U.S. Department
of Transportation
**Federal Aviation
Administration**

FAA Form 5100-132, Project Plans and Specifications – Airport Improvement Program Sponsor Certification

Paperwork Reduction Act Statement

A federal agency may not conduct or sponsor, and a person is not required to respond to, nor shall a person be subject to a penalty for failure to comply with a collection of information subject to the requirements of the Paperwork Reduction Act unless that collection of information displays a currently valid OMB Control Number. The OMB Control Number for this information collection is 2120-0569. Public reporting for this collection of information is estimated to be approximately 8 hours per response, including the time for reviewing instructions, searching existing data sources, gathering and maintaining the data needed, completing and reviewing the collection of information. All responses to this collection of information are required under 49 U.S.C. Section 47105 to retain a benefit and to meet the reporting requirements of 2 CFR 200. Send comments regarding this burden estimate or any other aspect of this collection of information, including suggestions for reducing this burden to: Information Collection Clearance Officer, Federal Aviation Administration, 10101 Hillwood Parkway, Fort Worth, TX 76177-1524.

Project Plans and Specifications

Airport Improvement Program Sponsor Certification

Sponsor:

Airport:

Project Number:

Description of Work:

Application

49 USC § 47105(d) authorizes the Secretary to require certification from the sponsor that it will comply with the statutory and administrative requirements in carrying out a project under the Airport Improvement Program (AIP). Labor and civil rights standards applicable to AIP are established by the Department of Labor (www.dol.gov/). AIP Grant Assurance C.1—General Federal Requirements identifies applicable federal laws, regulations, executive orders, policies, guidelines and requirements for assistance under AIP. A list of current advisory circulars with specific standards for procurement, design or construction of airports, and installation of equipment and facilities is referenced in standard airport sponsor Grant Assurance 34 contained in the grant agreement.

Certification Statements

Except for certification statements below marked as not applicable (N/A), this list includes major requirements of the construction project. Selecting “Yes” represents sponsor acknowledgement and confirmation of the certification statement. The term “will” means Sponsor action taken at appropriate time based on the certification statement focus area, but no later than the end of the project period of performance. This list is not comprehensive and does not relieve the sponsor from fully complying with all applicable statutory and administrative standards. The source of the requirement is referenced within parenthesis.

1. The plans and specifications were or will be prepared in accordance with applicable federal standards and requirements, so that no deviation or modification to standards set forth in the advisory circulars, or FAA-accepted state standard, is necessary other than those explicitly approved by the Federal Aviation Administration (FAA) (14 USC § 47105).

Yes No N/A

2. Specifications incorporate or will incorporate a clear and accurate description of the technical requirement for the material or product that does not contain limiting or proprietary features that unduly restrict competition (2 CFR §200.319).

Yes No N/A

3. The development that is included or will be included in the plans is depicted on the current airport layout plan as approved by the FAA (14 USC § 47107).

Yes No N/A

4. Development and features that are ineligible or unallowable for AIP funding have been or will be omitted from the plans and specifications (FAA Order 5100.38, par. 3-43).

Yes No N/A

5. The specification does not use or will not use "brand name" or equal to convey requirements unless sponsor requests and receives approval from the FAA to use brand name (FAA Order 5100.38, Table U-5).

Yes No N/A

6. The specification does not impose or will not impose geographical preference in their procurement requirements (2 CFR §200.319(b) and FAA Order 5100.38, Table U-5).

Yes No N/A

7. The use of prequalified lists of individuals, firms or products include or will include sufficient qualified sources that ensure open and free competition and that does not preclude potential entities from qualifying during the solicitation period (2 CFR §319(d)).

Yes No N/A

8. Solicitations with bid alternates include or will include explicit information that establish a basis for award of contract that is free of arbitrary decisions by the sponsor (2 CFR § 200.319(a)(7)).

Yes No N/A

9. Concurrence was or will be obtained from the FAA if Sponsor incorporates a value engineering clause into the contract (FAA Order 5100.38, par. 3-57).

Yes No N/A

10. The plans and specifications incorporate or will incorporate applicable requirements and recommendations set forth in the federally approved environmental finding (49 USC §47106(c)).

Yes No N/A

11. The design of all buildings comply or will comply with the seismic design requirements of 49 CFR § 41.120. (FAA Order 5100.38d, par. 3-92)

Yes No N/A

12. The project specification include or will include process control and acceptance tests required for the project by as per the applicable standard:

a. Construction and installation as contained in Advisory Circular (AC) 150/5370-10.

Yes No N/A

b. Snow Removal Equipment as contained in AC 150/5220-20.

Yes No N/A

c. Aircraft Rescue and Fire Fighting (ARFF) vehicles as contained in AC 150/5220-10.

Yes No N/A

13. For construction activities within or near aircraft operational areas(AOA):

a. The Sponsor has or will prepare a construction safety and phasing plan (CSPP) conforming to Advisory Circular 150/5370-2.

b. Compliance with CSPP safety provisions has been or will be incorporated into the plans and specifications as a contractor requirement.

c. Sponsor will not initiate work until receiving FAA's concurrence with the CSPP (FAA Order 5100.38, Par. 5-29).

Yes No N/A

14. The project was or will be physically completed without federal participation in costs due to errors and omissions in the plans and specifications that were foreseeable at the time of project design (49 USC §47110(b)(1) and FAA Order 5100.38d, par. 3-100).

Yes No N/A

Attach documentation clarifying any above item marked with "No" response.

Sponsor's Certification

I certify, for the project identified herein, responses to the forgoing items are accurate as marked and additional documentation for any item marked "no" is correct and complete.

Executed on this day of , .

Name of Sponsor:

Name of Sponsor's Authorized Official:

Title of Sponsor's Authorized Official:

Signature of Sponsor's Authorized Official: _____

I declare under penalty of perjury that the foregoing is true and correct. I understand that knowingly and willfully providing false information to the federal government is a violation of 18 USC § 1001 (False Statements) and could subject me to fines, imprisonment, or both.



U.S. Department
of Transportation
**Federal Aviation
Administration**

FAA Form 5100-134, Selection of Consultants – Airport Improvement Program Sponsor Certification

Paperwork Reduction Act Statement

A federal agency may not conduct or sponsor, and a person is not required to respond to, nor shall a person be subject to a penalty for failure to comply with a collection of information subject to the requirements of the Paperwork Reduction Act unless that collection of information displays a currently valid OMB Control Number. The OMB Control Number for this information collection is 2120-0569. Public reporting for this collection of information is estimated to be approximately 8 hours per response, including the time for reviewing instructions, searching existing data sources, gathering and maintaining the data needed, completing and reviewing the collection of information. All responses to this collection of information are required under 49 U.S.C. Section 47105 to retain a benefit and to meet the reporting requirements of 2 CFR 200. Send comments regarding this burden estimate or any other aspect of this collection of information, including suggestions for reducing this burden to: Information Collection Clearance Officer, Federal Aviation Administration, 10101 Hillwood Parkway, Fort Worth, TX 76177-1524.



Selection of Consultants Airport Improvement Program Sponsor Certification

Sponsor:

Airport:

Project Number:

Description of Work:

Application

49 USC § 47105(d) authorizes the Secretary to require certification from the sponsor that it will comply with the statutory and administrative requirements in carrying out a project under the Airport Improvement Program (AIP). General requirements for selection of consultant services within federal grant programs are described in 2 CFR §§ 200.317-200.326. Sponsors may use other qualifications-based procedures provided they are equivalent to standards of Title 40 chapter 11 and FAA Advisory Circular 150/5100-14, Architectural, Engineering, and Planning Consultant Services for Airport Grant Projects.

Certification Statements

Except for certification statements below marked as not applicable (N/A), this list includes major requirements of the construction project. Selecting "Yes" represents sponsor acknowledgement and confirmation of the certification statement. The term "will" means Sponsor action taken at appropriate time based on the certification statement focus area, but no later than the end of the project period of performance. This list is not comprehensive and does not relieve the sponsor from fully complying with all applicable statutory and administrative standards. The source of the requirement is referenced within parenthesis.

1. Sponsor acknowledges their responsibility for the settlement of all contractual and administrative issues arising out of their procurement actions (2 CFR § 200.318(k)).

Yes No N/A

2. Sponsor procurement actions ensure or will ensure full and open competition that does not unduly limit competition (2 CFR § 200.319).

Yes No N/A

3. Sponsor has excluded or will exclude any entity that develops or drafts specifications, requirements, or statements of work associated with the development of a request-for-qualifications (RFQ) from competing for the advertised services (2 CFR § 200.319).

Yes No N/A

4. The advertisement describes or will describe specific project statements-of-work that provide clear detail of required services without unduly restricting competition (2 CFR § 200.319).
 Yes No N/A

5. Sponsor has publicized or will publicize a RFQ that:
 - a. Solicits an adequate number of qualified sources (2 CFR § 200.320(d)); and
 - b. Identifies all evaluation criteria and relative importance (2 CFR § 200.320(d)).
 Yes No N/A

6. Sponsor has based or will base selection on qualifications, experience, and disadvantaged business enterprise participation with price not being a selection factor (2 CFR § 200.320(d)).
 Yes No N/A

7. Sponsor has verified or will verify that agreements exceeding \$25,000 are not awarded to individuals or firms suspended, debarred or otherwise excluded from participating in federally assisted projects (2 CFR §180.300).
 Yes No N/A

8. A/E services covering multiple projects: Sponsor has agreed to or will agree to:
 - a. Refrain from initiating work covered by this procurement beyond five years from the date of selection (AC 150/5100-14); and
 - b. Retain the right to conduct new procurement actions for projects identified or not identified in the RFQ (AC 150/5100-14).
 Yes No N/A

9. Sponsor has negotiated or will negotiate a fair and reasonable fee with the firm they select as most qualified for the services identified in the RFQ (2 CFR § 200.323).
 Yes No N/A

10. The Sponsor's contract identifies or will identify costs associated with ineligible work separately from costs associated with eligible work (2 CFR § 200.302).
 Yes No N/A

11. Sponsor has prepared or will prepare a record of negotiations detailing the history of the procurement action, rationale for contract type and basis for contract fees (2 CFR §200.318(i)).
 Yes No N/A

12. Sponsor has incorporated or will incorporate mandatory contact provisions in the consultant contract for AIP-assisted work (49 U.S.C. Chapter 471 and 2 CFR part 200 Appendix II)
 Yes No N/A

13. For contracts that apply a time-and-material payment provision (also known as hourly rates, specific rates of compensation, and labor rates), the Sponsor has established or will establish:

- a. Justification that there is no other suitable contract method for the services (2 CFR §200.318(j));
- b. A ceiling price that the consultant exceeds at their risk (2 CFR §200.318(j)); and
- c. A high degree of oversight that assures consultant is performing work in an efficient manner with effective cost controls in place 2 CFR §200.318(j)).

Yes No N/A

14. Sponsor is not using or will not use the prohibited cost-plus-percentage-of-cost (CPPC) contract method. (2 CFR § 200.323(d)).

Yes No N/A

Attach documentation clarifying any above item marked with "no" response.

Sponsor's Certification

I certify, for the project identified herein, responses to the forgoing items are accurate as marked and additional documentation for any item marked "no" is correct and complete.

I declare under penalty of perjury that the foregoing is true and correct. I understand that knowingly and willfully providing false information to the federal government is a violation of 18 USC § 1001 (False Statements) and could subject me to fines, imprisonment, or both.

Executed on this day of , .

Name of Sponsor:

Name of Sponsor's Authorized Official:

Title of Sponsor's Authorized Official:

Signature of Sponsor's Authorized Official: _____

I declare under penalty of perjury that the foregoing is true and correct. I understand that knowingly and willfully providing false information to the federal government is a violation of 18 USC § 1001 (False Statements) and could subject me to fines, imprisonment, or both.



U.S. Department
of Transportation
**Federal Aviation
Administration**

FAA Form 5100-135, Certification and Disclosure Regarding Potential Conflicts of Interest – Airport Improvement Program Sponsor Certification

Paperwork Reduction Act Statement

A federal agency may not conduct or sponsor, and a person is not required to respond to, nor shall a person be subject to a penalty for failure to comply with a collection of information subject to the requirements of the Paperwork Reduction Act unless that collection of information displays a currently valid OMB Control Number. The OMB Control Number for this information collection is 2120-0569. Public reporting for this collection of information is estimated to be approximately 8 hours per response, including the time for reviewing instructions, searching existing data sources, gathering and maintaining the data needed, completing and reviewing the collection of information. All responses to this collection of information are required under 49 U.S.C. Section 47105 to retain a benefit and to meet the reporting requirements of 2 CFR 200. Send comments regarding this burden estimate or any other aspect of this collection of information, including suggestions for reducing this burden to: Information Collection Clearance Officer, Federal Aviation Administration, 10101 Hillwood Parkway, Fort Worth, TX 76177-1524.



Certification and Disclosure Regarding Potential Conflicts of Interest Airport Improvement Program Sponsor Certification

Sponsor:

Airport:

Project Number:

Description of Work:

Application

Title 2 CFR § 200.112 and § 1201.112 address Federal Aviation Administration (FAA) requirements for conflict of interest. As a condition of eligibility under the Airport Improvement Program (AIP), sponsors must comply with FAA policy on conflict of interest. Such a conflict would arise when any of the following have a financial or other interest in the firm selected for award:

- a) The employee, officer or agent,
- b) Any member of his immediate family,
- c) His or her partner, or
- d) An organization which employs, or is about to employ, any of the above.

Selecting "Yes" represents sponsor or sub-recipient acknowledgement and confirmation of the certification statement. Selecting "No" represents sponsor or sub-recipient disclosure that it cannot fully comply with the certification statement. If "No" is selected, provide support information explaining the negative response as an attachment to this form. This includes whether the sponsor has established standards for financial interest that are not substantial or unsolicited gifts are of nominal value (2 CFR § 200.318(c)). The term "will" means Sponsor action taken at appropriate time based on the certification statement focus area, but no later than the end of the project period of performance.

Certification Statements

1. The sponsor or sub-recipient maintains a written standards of conduct governing conflict of interest and the performance of their employees engaged in the award and administration of contracts (2 CFR § 200.318(c)). To the extent permitted by state or local law or regulations, such standards of conduct provide for penalties, sanctions, or other disciplinary actions for violations of such standards by the sponsor's and sub-recipient's officers, employees, or agents, or by contractors or their agents.

Yes No



U.S. Department
of Transportation
**Federal Aviation
Administration**

FAA Form 5100-145, FAA Title VI Pre-Grant Award Checklist

Paperwork Reduction Act Statement

A federal agency may not conduct or sponsor, and a person is not required to respond to, nor shall a person be subject to a penalty for failure to comply with a collection of information subject to the requirements of the Paperwork Reduction Act unless that collection of information displays a currently valid OMB Control Number. The OMB Control Number for this information collection is 2120-0569. Public reporting for this collection of information is estimated to be approximately 8 hours per response, including the time for reviewing instructions, searching existing data sources, gathering, and maintaining the data needed, completing and reviewing the collection of information.

All responses to this collection of information are required under 49 U.S.C. Section 47105 to retain a benefit and to meet the reporting requirements of 2 CFR 200. Send comments regarding this burden estimate or any other aspect of this collection of information, including suggestions for reducing this burden to: Information Collection Clearance Officer, Federal Aviation Administration, 10101 Hillwood Parkway, Fort Worth, TX 76177-1524

Instructions for Form 5100-145, FAA Title VI Pre-Grant Award Checklist

This Checklist must be completed and submitted by the sponsor as a part of each FAA grant application.

"Yes" responses mean that the sponsor is currently in compliance or has a corrective action plan approved by the FAA Office of Civil Rights (FAA) to come into compliance. "No" responses mean there is a potential compliance issue. Compliance issues will be brought to the attention of the FAA to determine if corrective actions are necessary. If there are any questions, please contact ACR-4-TitleVI@faa.gov.

References to "Title VI" in this checklist include Title VI of the Civil Rights Act of 1964 and related authorities that expand or clarify nondiscrimination protections in FAA assisted programs, identified in [FAA Order 1400.11](#)

[https://www.faa.gov/regulations_policies/orders_notices/index.cfm/go/document.current/documentNumber/1400.11].

FAA Title VI Pre-Grant Award Checklist

Submission information

Submission date (Pick a date):

Name of airport sponsor:

Submitter's name:

Title:

Phone number:

Section 1: Questions Concerning Prior Approval of Title VI Program

By selecting "Yes" below, the sponsor certifies that the following documents were provided to, and approved by, the FAA Office of Civil Rights, and documentation of FAA's approval has been received by the sponsor. The FAA Office reviewing this grant application will confirm the FAA's approval of the documents in this Section prior to approving the grant application.

A sponsor that has **both** a Title VI* Plan and a Community Participation Plan, **both** of which are approved by the FAA and current, and has already received approval for the information outlined in this Checklist, does not need to complete the remaining questions in Sections 2 and 3 of this Checklist.

This information is required based on [DOT Order 1000.12C, Ch. II, Secs. 3 and 4](https://www.transportation.gov/mission/us-department-transportation-title-vi-program)
[https://www.transportation.gov/mission/us-department-transportation-title-vi-program].

Criterion	Notes	Response	Comments
<p>1.1 The sponsor has a written Title VI Plan, approved by the FAA Office of Civil Rights, and subsequently adopted by the recipient, and documentation of the approval and adoption.</p>	<p>Sponsors must develop and adopt a Title VI Plan that outlines the recipient’s measures to ensure compliance with Title VI. A current Title VI Plan on file with the FAA is sufficient if the Plan is no more than 3 years old.</p> <p>If the sponsor does not have an approved Title VI Plan, select "No" and complete Sections 2 and 3 of this Checklist.</p>	<p>Yes No</p>	
<p>1.2 The sponsor has a written Community Participation Plan (CPP), or an equivalent public participation plan (PPP), and documented approval or concurrence of the plan from the FAA Office of Civil Rights.</p>	<p>Sponsors must satisfy CPP requirements as a condition of receiving an award of federal financial assistance. To the extent the sponsor has already prepared a PPP as part of planning or other requirements of FAA or DOT, that plan or plans may satisfy the CPP requirement so long as the plan has incorporated the Title VI requirements as provided in DOT Order 1000.12C, Ch. II, Sec. 4(a-j).</p> <p>If the sponsor does not have an approved CPP or PPP, select "No" and answer question 3.5 in Section 3 of this Checklist.</p>	<p>Yes No</p>	

If the answers to 1.1 and 1.2 above are both “Yes,” do *not* complete Sections 2 and 3.

Section 2: Questions Concerning Applicant Data

By selecting "Yes" below, the sponsor certifies that the following documents have been collected in its records prior to submitting this grant application and will be timely made available to FAA staff, including from the FAA Offices of Airports, Chief Counsel, and Civil Rights, upon request.

"Timely available" usually means within 1 week or less, depending on the scope and circumstances. The data should already be available in a format that can be forwarded, as-is. No further data collection or summarization efforts should be necessary to respond to the request.

This information is required by DOT Order 1000.12C, Ch. II, Sec. 2; 49 CFR 21.9; and FAA Order 1400.11.

Criterion	Notes	Response	Comments
<p>2.1 The sponsor has, on file, demographic information for the surrounding community and communities otherwise affected by the sponsor's facilities and operations, including any airport noise and relocations.</p>	<p>At a minimum, data is required for race, color, national origin, and limited English proficiency (LEP) populations. The collected data must include the most current U.S. Census Bureau data, where available, such as American Community Survey data.</p> <p>EJScreen [www.epa.gov/ejscreen] is a useful resource for assessing project areas.</p>	<p>Yes</p> <p>No</p>	
<p>2.2 The sponsor has, on file, demographic information for beneficiaries. For example, if the applicant is an airport operator, it has collected information for its airport customers.</p>	<p>In most cases, this type of information is available through voluntary disclosures by customers, lessees, community meeting attendees, and businesses seeking opportunities with the applicant.</p> <p>If not applicable or after reasonable efforts, no information was collected, respond, "Yes."</p>	<p>Yes</p> <p>No</p>	

Criterion	Notes	Response	Comments
<p>2.3 The sponsor has, on file, demographic information for their staff.</p>	<p>In most cases, this type of information is available through voluntary disclosures. See also 49 CFR § 21.5(c).</p> <p>If not applicable or after reasonable efforts, no information was collected, respond, "Yes."</p>	<p>Yes No</p>	
<p>2.4 The sponsor has, on file, demographic information for individuals who are members of planning or advisory boards overseeing the applicant's programs, including its airport operations (if applicable).</p>	<p>Airport sponsors, the most common FAA grant applicants, commonly have appointed boards or are overseen directly by elected bodies, such as city councils. In addition, input for specific projects or sponsor priorities is often provided by standing appointed committees. If not already available, the information can be requested on a voluntary basis.</p> <p>If not applicable or after reasonable efforts, no information was collected, respond, "Yes."</p>	<p>Yes No</p>	

Section 3: Questions about the Sponsor's Programs

By choosing "Yes" below, the sponsor certifies that the related statements are true.

This information is required by DOT Order 1000.12C, Ch. II, Secs. 2, 3, and 4.

Criterion	Notes	Response	Comments
<p>3.1 The sponsor's programs, including any airport operations, have been evaluated for potential impact based on race, color, national origin (including limited English proficiency (LEP)), or low-income status as part of an environmental review process consistent with FAA requirements.</p>	<p>Relevant requirements include Title VI of the Civil Rights Act of 1964 (42 U.S.C. 2000d, et seq.) ("Title VI"), DOT's Title VI regulations at 49 CFR part 21, Executive Order 12898, and DOT Order on Environmental Justice (Order 5610.2C).</p> <p>See Title VI of the Civil Rights Act of 1964 [www.justice.gov/crt/fcs/TitleVI];</p> <p>49 CFR part 21 [www.ecfr.gov]</p> <p>DOT Order on Environmental Justice [www.transportation.gov/transportation-policy/environmental-justice]</p>	<p>Yes</p> <p>No</p>	
<p>3.2 The sponsor has evaluated Checklist Section 2 data to identify any potential disparities based on race, color, or national origin (including LEP), as part of an analysis to identify potential discriminatory effects, consistent with FAA requirements.</p>	<p>Relevant requirements include Title VI of the Civil Rights Act of 1964 (42 U.S.C. 2000d, et seq.) ("Title VI"), DOT's Title VI regulations at 49 CFR part 21, Executive Order 12898, and DOT Order on Environmental Justice (Order 5610.2C).</p>	<p>Yes</p> <p>No</p>	

Criterion	Notes	Response	Comments
<p>3.3 The sponsor has performed a “Four-Factor” LEP analysis for the sponsor’s programs, including its airport operations (if applicable). Plans and procedures and resources are in place to meet the identified LEP needs, consistent with the analysis.</p>	<p>A “Yes” response means yes to both parts of the question. The LEP analysis must be consistent with Executive Order 13166 and DOT Policy Guidance Concerning Recipients’ Responsibilities to LEP Persons (70 FR 74087, December 14, 2005).</p> <p>See DOT’s LEP Guidance [https://www.transportation.gov/civil-rights/civil-rights-awareness-enforcement/dots-lep-guidance].</p>	<p>Yes No</p>	
<p>3.4 If the sponsor is an airport sponsor, the FAA Unlawful Discrimination Poster is displayed at its public airport facilities.</p> <p>If the sponsor is not an airport sponsor, it uses other effective methods to inform its customers, clients, beneficiaries, etc., that it will not discriminate based on race, color, national origin (including LEP), age, sex (including sexual orientation and gender identity), or creed, and of how to file a complaint of discrimination under Title VI against the applicant.</p>	<p>For airport sponsors, areas where the posters should be displayed include, as applicable, airport terminals, fixed base operator facilities, and at businesses that are open to the public and operating on airport property, such as hotels. For larger facilities, posters should be placed so that people can reasonably be expected to see them, no matter where they are in the facility. The poster is available at Airport Civil Rights Program – National Airport Policy and Compliance [https://www.faa.gov/about/office_org/headquarters_offices/acr/com_civ_support/national_airport_policy_compliance/].</p> <p>If applicant is not an airport, the method used to inform the public must be ongoing and documented.</p>	<p>Yes No</p>	

Criterion	Notes	Response	Comments
<p>3.5 The sponsor's practices for obtaining proactive and meaningful public participation to ensure that (1) beneficiaries, as well as contractors and sub-recipients (if applicable), are adequately informed about how programs, projects, and other activities will potentially affect them, and</p> <p>(2) diverse views are heard and considered throughout all stages of consultation, planning, and decision-making processes.</p>	<p>To demonstrate compliance with Title VI, the sponsor must specifically be able to show how it affords all members of the community equal opportunity to provide input, regardless of race, color, national origin (including LEP), sex (including sexual orientation and gender identity), creed, or age, in accordance with Title VI, 49 U.S.C. § 47123, Executive Orders 12898 and 13166, DOT Order 5610.2C, and the DOT LEP guidance at 70 FR 74087.</p> <p>Please skip this question if the sponsor has an FAA-approved community participation plan.</p>	<p>Yes</p> <p>No</p>	
<p>3.6 Detailed information for all of the sponsor's Title VI lawsuits, investigations, and complaints filed or pending within the last 2 years been uploaded to the FAA Civil Rights Connect System or sent to ACR-4-TitleVI@faa.gov, with receipt acknowledged.</p>	<p>Sponsors must provide the FAA with both the initial notifications for the individual lawsuits, investigation, and complaints, and status updates. The updates are required until at least the time of grant closeout. The updates must include at least the outcome of the lawsuits, investigation, and complaint, and confirmation for resolution of identified deficiencies.</p> <p>See Appendix C to 49 CFR 21, Sub-part (b)(3) [available through www.ecfr.gov].</p> <p>"Title VI lawsuits, investigations, and complaints" include those alleging discrimination based on race, color, national origin (including LEP), sex (including sexual orientation and gender identity), creed or age.</p>	<p>Yes</p> <p>No</p>	

Criterion	Notes	Response	Comments
<p>3.7 Detailed information for all Title VI oversight activities (including audits, compliance reviews, and assessments for the sponsor) performed or pending within the last 2 years, has been sent to ACR-4-TitleVI@faa.gov, with receipt acknowledged. This requirement does not apply to oversight activities conducted by FAA.</p>	<p>Sponsors must provide the FAA with both the initial notifications for the individual audits, compliance reviews, and assessment, and status updates. The updates are required until at least the time of grant closeout. The updates must include at least the outcome of the audits, compliance reviews, and assessment, and confirmation for resolution of identified deficiencies.</p> <p>See Appendix C to 49 CFR 21, Sub-part (b)(3) [available through www.ecfr.gov].</p>	<p>Yes</p> <p>No</p>	
<p>3.8 Detailed information for any pending grant applications with Federal agencies other than FAA identified in the grant application.</p>	<p>The information should be included in narrative fields of the pending application.</p>	<p>Yes</p> <p>No</p>	

CERTIFICATION REGARDING LOBBYING

Certification for Contracts, Grants, Loans, and Cooperative Agreements

The undersigned certifies, to the best of his or her knowledge and belief, that:

(1) No Federal appropriated funds have been paid or will be paid, by or on behalf of the undersigned, to any person for influencing or attempting to influence an officer or employee of an agency, a Member of Congress, an officer or employee of Congress, or an employee of a Member of Congress in connection with the awarding of any Federal contract, the making of any Federal grant, the making of any Federal loan, the entering into of any cooperative agreement, and the extension, continuation, renewal, amendment, or modification of any Federal contract, grant, loan, or cooperative agreement.

(2) If any funds other than Federal appropriated funds have been paid or will be paid to any person for influencing or attempting to influence an officer or employee of any agency, a Member of Congress, an officer or employee of Congress, or an employee of a Member of Congress in connection with this Federal contract, grant, loan, or cooperative agreement, the undersigned shall complete and submit Standard Form-LLL, "Disclosure of Lobbying Activities," in accordance with its instructions.

(3) The undersigned shall require that the language of this certification be included in the award documents for all subawards at all tiers (including subcontracts, subgrants, and contracts under grants, loans, and cooperative agreements) and that all subrecipients shall certify and disclose accordingly. This certification is a material representation of fact upon which reliance was placed when this transaction was made or entered into. Submission of this certification is a prerequisite for making or entering into this transaction imposed by section 1352, title 31, U.S. Code. Any person who fails to file the required certification shall be subject to a civil penalty of not less than \$10,000 and not more than \$100,000 for each such failure.

Statement for Loan Guarantees and Loan Insurance

The undersigned states, to the best of his or her knowledge and belief, that:

If any funds have been paid or will be paid to any person for influencing or attempting to influence an officer or employee of any agency, a Member of Congress, an officer or employee of Congress, or an employee of a Member of Congress in connection with this commitment providing for the United States to insure or guarantee a loan, the undersigned shall complete and submit Standard Form-LLL, "Disclosure of Lobbying Activities," in accordance with its instructions. Submission of this statement is a prerequisite for making or entering into this transaction imposed by section 1352, title 31, U.S. Code. Any person who fails to file the required statement shall be subject to a civil penalty of not less than \$10,000 and not more than \$100,000 for each such failure.

* APPLICANT'S ORGANIZATION

Albany County Airport Authority-Albany International Airport

* PRINTED NAME AND TITLE OF AUTHORIZED REPRESENTATIVE

Prefix: * First Name: Philip Middle Name: F.

* Last Name: Calderone Suffix: Esq.

* Title: Chief Executive Officer

* SIGNATURE:

Philip F. Calderone

* DATE: 06/27/2024

Concourse A Modernization and Enhancement

Albany International Airport



Project Overview

The purpose of this project is for the modernization and enhancement of the existing Concourse A at the Albany International Airport. The facility, as it stands and operates today, was constructed in 1979. No comprehensive rehabilitation of the facility has taken place since the original construction, with only minor improvements in the past 44 years. This aging infrastructure will be completely modernized as part of the proposed project. This facility will gain two (2) additional passenger boarding bridge gate positions which can accommodate a typical domestic commercial aircraft. These two new gate positions, along with intended common-use operations, will increase competition which will in-turn provide improved air travel access to the community.

The new gates will be configured to favor common-use operations, where airlines can be interchanged with ease to provide maximum flexibility and capacity gains. The facility's interior will be modernized and refurbished to provide the traveling public with modern infrastructure and amenities. Interior spaces will be organized per modern industry best-practices to allow for an efficient wayfinding experience, accessible waiting areas, and new ADA accessible companion restroom, and more. The modernization of the facility will increase the overall energy efficiency of Concourse A through HVAC and insulation improvements.

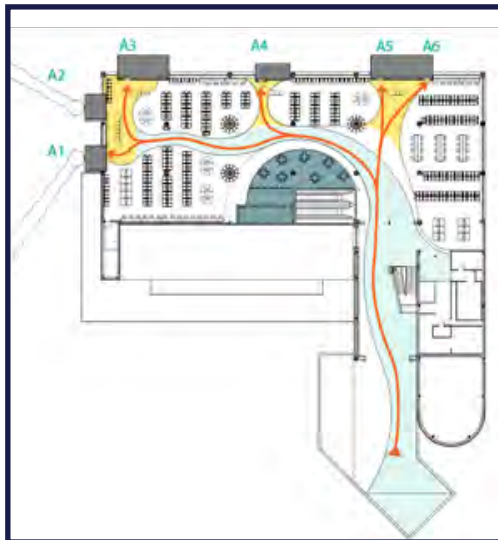

Project Fly-Through Video

General Project Location



Project Details

Primary Benefits



- * Increase airline and passenger capacity
- * Increase new airline entrant access
- * Increase airline competition
- * Deliver air travel affordability & access to the community
- * Enhanced ADA Accessibility

Enhancement Highlights



- * 2 additional boarding gate positions
- * Accommodate B737 Max 10 or similar
- * HVAC energy efficiency increase
- * Interior lighting energy efficiency increase
- * Modern passenger facilities
- * Streamlined passenger movement areas
- * Organized passenger wait areas

Cost Estimates

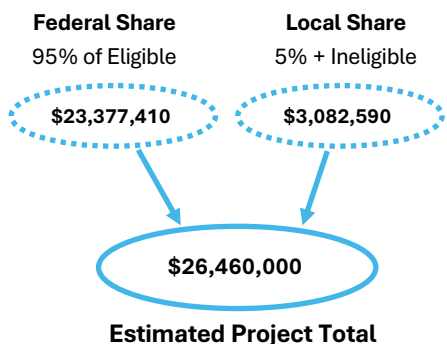

How does this Project meet the Bipartisan Infrastructure Law Considerations?

Capacity	Aging Infrastructure	ADA Accessibility	Competition	Job Creation
----------	----------------------	-------------------	-------------	--------------

Concourse A Modernization and Enhancement

Albany International Airport

The New York Capital Region's steady economic growth will require a modern air transportation hub.

Albany International Airport is ready to **modernize** for the **future**.

Albany's Rank in U.S. News "10 Best Places to Find a Job in Technology"

3

News Report:

Global Foundries buys additional 800 acres of land in Malta NY for expanding semiconductor manufacturing and research facilities

(May 2023)

Capital Region based research centers such as:

NYCREATES (Albany Nanotech / SUNY Polytechnic Institute)

Global Foundries

GE Global Research

Rensselaer Polytech Institute

Regeneron

Knolls Atomic Power Lab

What was happening in 1979 when Concourse A was originally built?

- * Cost of a Super Bowl Ad: \$185,000
- * McDonald's introduced the Happy Meal
- * Sony released the Walkman
- * Michael Jackson released *Off the Wall*
- * ESPN launched on cable television
- * Voyager 1 reveals photos of Jupiter's Rings

44 years later, it is time for modernization

NYS Capital Region Rank for "U.S. Cities Where Manufacturing is Thriving"

7

Questions or need additional information?

Contact:

Connor Haskin, Chief Airport Planner

Albany International Airport

Chaskin@albanyairport.com

518-242-2239

INCREASED CAPACITY AND ACCESS

- 2 ADDITIONAL GATES SUPPORTING TYPE III AIRCRAFT
- ADDITIONAL FLOOR AREA FOR SEATING
- ENCOURAGE ACTUAL AND POTENTIAL COMPETITION

“Potential for new or lesser-known airlines”¹

E.O. 14036 Promoting Competition in the American Economy

¹ <https://www.federalregister.gov/d/2021-15069/p-118>

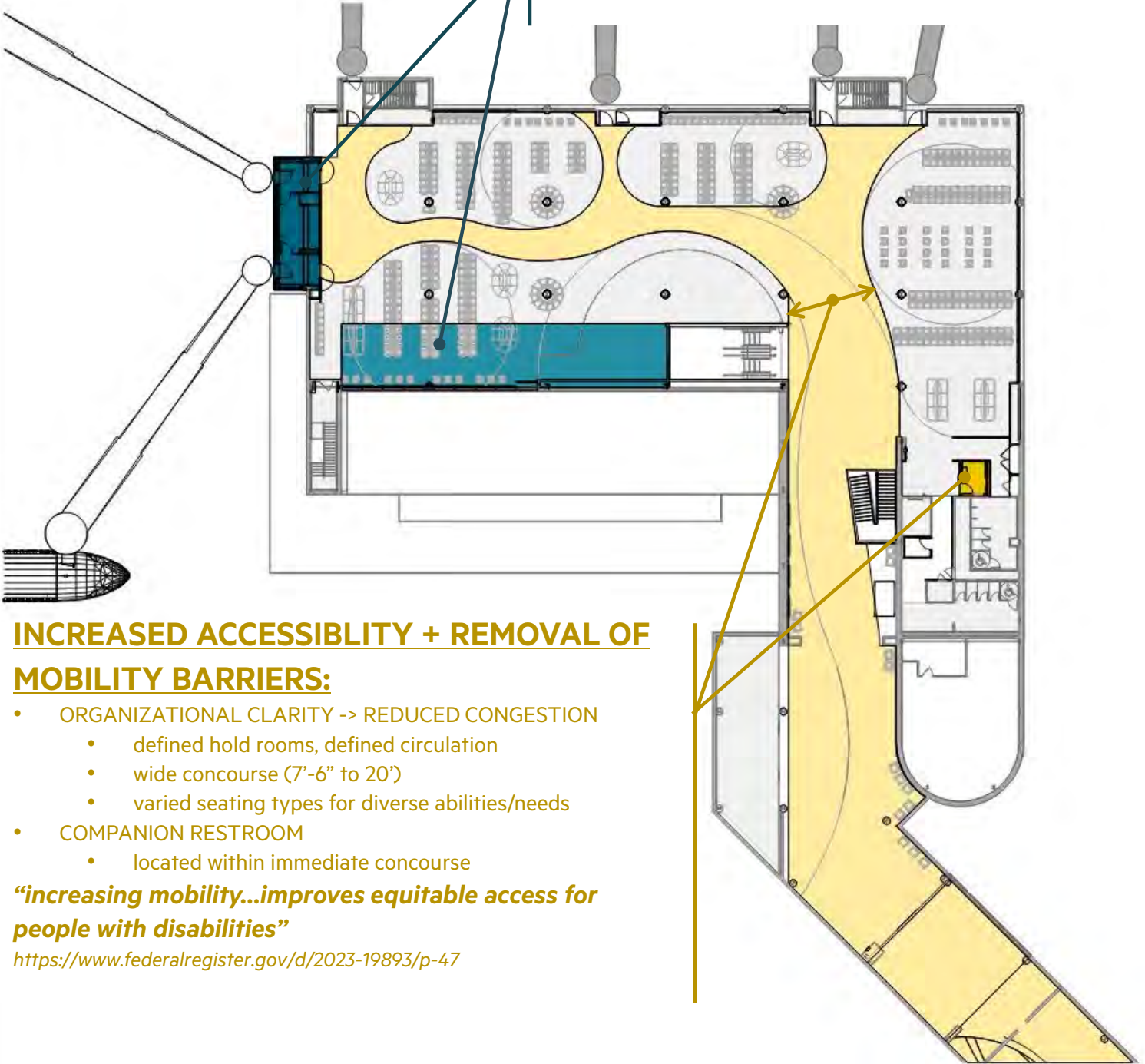

INCREASED ACCESSIBILITY + REMOVAL OF MOBILITY BARRIERS:

- ORGANIZATIONAL CLARITY -> REDUCED CONGESTION
 - defined hold rooms, defined circulation
 - wide concourse (7'-6" to 20')
 - varied seating types for diverse abilities/needs
- COMPANION RESTROOM
 - located within immediate concourse

“increasing mobility...improves equitable access for people with disabilities”

<https://www.federalregister.gov/d/2023-19893/p-47>



REPLACING AGING INFRASTRUCTURE

- REDUCTION IN CONSTRUCTION/DEMOLITION WASTE AND UTILIZATION OF EXISTING EMBODIED ENERGY W/ BY EXTENDING USEFUL LIFE + VIABILITY OF EXISTING BUILDING.
- REUPHOLSTER & MODERNIZE EXISTING STEEL FRAME FURNITURE
- NEW DURABLE FINISHES AT HIGH TRAFFIC AREAS (TERRAZZO)
- ENERGY EFFICIENT LIGHTING

“...increase climate resilience + less emissions intensive pavement and construction materials as allowable, and reduce pollution”²

² Executive Order 14008, Tackling the Climate Crisis at Home and Abroad (86 FR 7619),

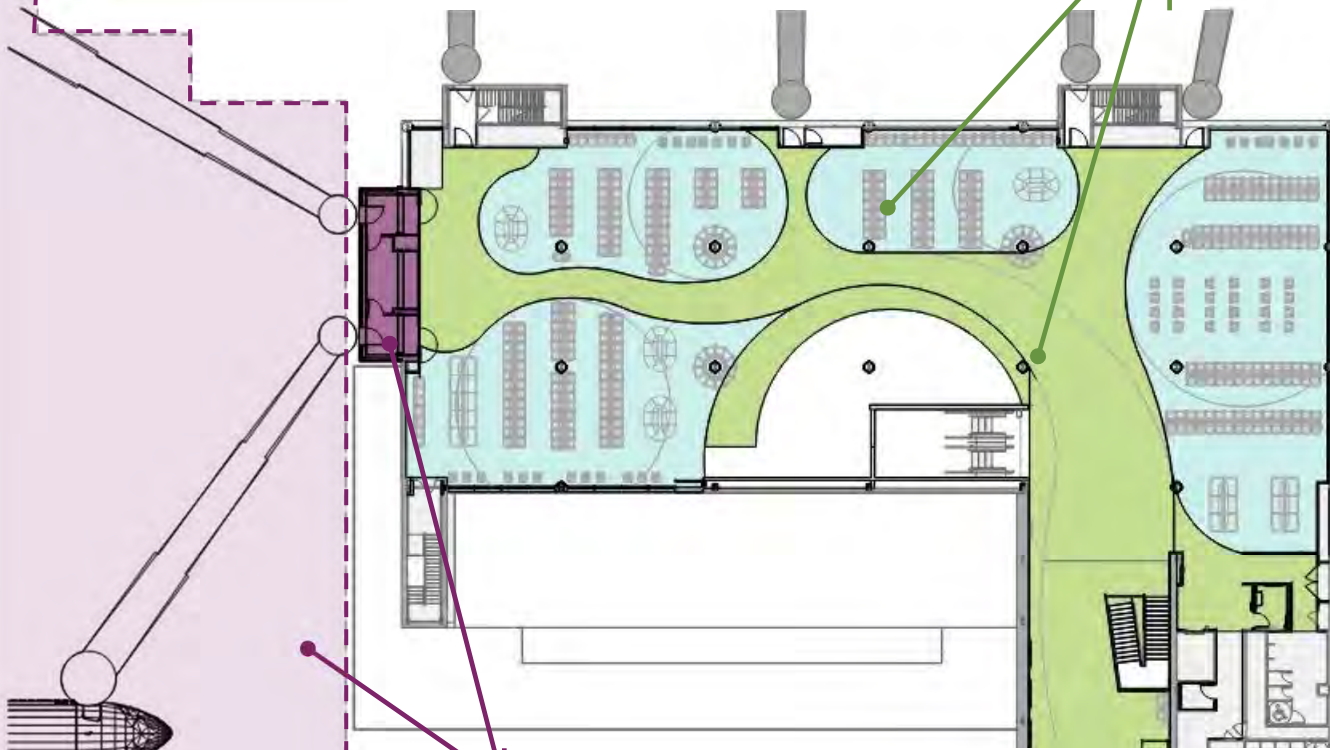

IMPROVES ENERGY EFFICIENCY

- ELECTRIC HEAT PUMPS AT ADDITION
- ENVIRONMENTALLY ACCOUNTABLE, LOW-EMITTING DURABLE MATERIALS
- REPURPOSE OF EXISTING IMPERVIOUS AREAS TO SERVE NEW PROGRAM, MAINTAINANCE OF EXISTING IMPERVIOUS/PERVIOUS RATIO

“to ensure federal infrastructure investment reduces climate pollution...consider greenhouse gas emissions”³

E.O. 14008 Tackling the Climate Crisis at Home and Abroad

³ <https://www.federalregister.gov/d/2021-02177/p-80>



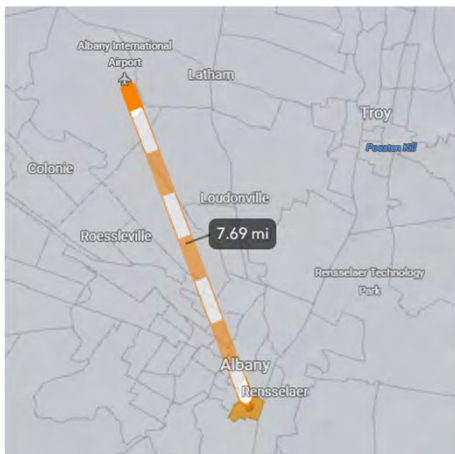

<https://adip.faa.gov/agis/public/#/disadvantagedCommunities>



https://ejsscreen.epa.gov/mapper/ejsscreen_SOE.aspx

IMPROVES AIRPORT ACCESS FOR HISTORICALLY DISADVANTAGED

- ALB IS LOCATED LESS THAN 10 MILES FROM THE ALBANY COUNTY DOT DISADVANTAGED COMMUNITY ⁵
- THE ADDITIONAL GATES WILL EXPAND ACCESS BY INCREASING FLIGHTS, AIRLINE COMPETITION AND PASSENGER CAPACITY. COST BARRIERS MAY BE REDUCED WITH THE ADDITIONAL AIRLINE CAPACITY + COMPETITION.
- ONGOING PUBLIC ENGAGEMENT HAS BEEN BOTH IN PERSON AND ONLINE TO MAXIMIZE OUTREACH, INCLUDING IN PERSON SESSIONS IN JUNE 2023 + PLANNED FOR FALL 2023.

“...address the challenges faced by individuals in underserved communities...as well as accessibility for persons with disabilities...” ⁶

⁵ <https://adip.faa.gov/agis/public/#/disadvantagedCommunities>

⁶ [Executive Order 13985, Advancing Racial Equity and Support for Underserved Communities Through the Federal Government \(86 FR 7009\)](#).

GOOD PAYING JOBS

- APPROX. \$6.9m IN SALARIES GENERATED W/ PROJECT
- HIGH LABOR STANDARDS THROUGH PUBLIC LABOR AGREEMENT AND COMMUNITY PARTNERS
- APPRENTICESHIP GOALS EXCEEDING 3:1 RATIO, REPLENISHING THE DECLINING SKILLED LABOR MARKET
- ADDITION LONG TERM AVIATION JOBS / ADDITIONAL CARRIER CAPACITY

“...invest efficiently and equitably; promote the competitiveness of the U.S. economy; improve job opportunities by focusing on high labor standards... effectively coordinate with State, local, Tribal, and territorial government partners” ⁷

⁷ [Executive Order 14052, Implementation of the Infrastructure Investments and Jobs Act \(86 FR 64355\)](#)

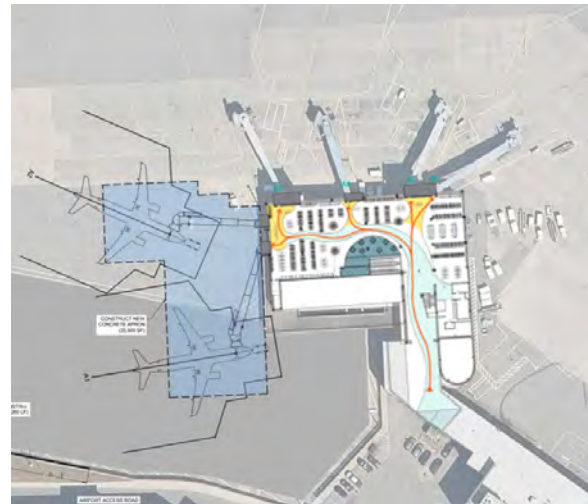

AGENDA ITEM NO. 12.2

**Grant Agreement: Authorization to Accept
Federal and State Grants – Runway 01/19
Rehabilitation & South Perimeter Road Construction**

AGENDA ITEM NO: 12.2
MEETING DATE: August 12, 2024

ALBANY COUNTY AIRPORT AUTHORITY
REQUEST FOR AUTHORIZATION

DEPARTMENT: *Planning and Environmental*

Contact Person: *Connor Haskin, ENV SP, Chief Airport Planner*

PURPOSE OF REQUEST:

Grant Agreement: *Authorization to Accept Federal and State Grants – Runway 01/19
Rehabilitation & South Perimeter Road Construction*

CONTRACT AMOUNT:

*Grant Amounts: \$9,326,858.00 – FAA 90%
\$518,159 – NYSDOT 5%
\$518,159 – ACAA 5%
\$10,363,176 – Total*

BUDGET INFORMATION:

Anticipated in Current ALB Capital Plan: Yes ✓ No ___ NA
Funding Account No.: N/A

FISCAL IMPACT - FUNDING (Dollars or Percentages)

Federal 90% State 5% Airport : 5%
Term of Funding: 2024 (FAA Fiscal Year)
Federal AIP Grant No.: 3-36-0001-153-2024 (Pending) ; NYSDOT Grant Pin No.: 1A00.32 ;

JUSTIFICATION:

Authorization is requested to accept both federal and state funding grants for the Runway 01/19 Rehabilitation & South Perimeter Road Construction. The funding split is 90% federal, 5% state, and 5% local, with the local share total sum of \$518,159. The total funding sum between both federal and state sources is \$9,845,017.

AGENDA ITEM NO: 12.2

MEETING DATE: August 12, 2024

PROCUREMENT DEPARTMENT APPROVAL:

Procurement complies with Authority Procurement Guidelines and Chief Financial Officer has approved. YES _____ NA ✓

CHIEF EXECUTIVE OFFICER'S RECOMMENDATION:

Recommend approval.

FINAL AGREEMENT SUBJECT TO APPROVAL BY COUNSEL: YES ✓ NA _____

BACK-UP MATERIAL:

Please refer to the attached final grant application package.



June 28th, 2024
By electronic transmittal

Ms. Evelyn Martinez, Manager
FAA New York Airports District Office
One Aviation Plaza, Suite 111
Jamaica, New York 11434

Subject: Albany International Airport Runway 01/19 Pavement Rehabilitation, Runway 01/19 Centerline & Runway 01 TDZ Lighting Upgrades, & South Perimeter Road Construction Final Grant Application

Dear Ms. Martinez:

I would like to cordially submit a final grant application for the proposed Airport Runway 01/19 Pavement Rehabilitation, Runway 01/19 Centerline & Runway 01 TDZ Lighting Upgrades, & South Perimeter Road Construction project. This submission replaces the pre-application submission on January 26th, 2024.

Enclosed please find the final grant application package. The project cost breakdown and associated application forms have been revised to reflect the attached bid table, associated design services, and anticipated construction inspection services. Please note that the Environmental Categorical Exclusion approval was issued on September 23rd, 2022. Airport Layout Plan and permanent structure airspace reviews were both approved as appropriate.

Thank you for your continued support with our capital improvement projects. Please do not hesitate to call Chief Airport Planner, Connor Haskin, at (518) 242-2239 if you require any additional information.

Sincerely,

Philip F. Calderone

Philip F. Calderone, Esq.,
Chief Executive Officer

cc: Rob Costa, FAA NYADO
Ralph Gatto, FAA NYADO
Lowell Lingo, NYSDOT
Keely Bannister, NYSDOT
Christine Quinn, ACAA
Michael F. Zonsius, ACAA
Margaret Herrmann, ACAA
John LaClair, ACAA
Connor Haskin, ACAA

Application for Federal Assistance SF-424

*1. Type of Submission: Preapplication Application Changed/Corrected Application	*2. Type of Application * If Revision, select appropriate letter(s): New Continuation * Other (Specify) Revision
---	---

*3. Date Received: _____ 4. Applicant Identifier: _____

5a. Federal Entity Identifier: _____ *5b. Federal Award Identifier: _____

State Use Only:

6. Date Received by State: _____ 7. State Application Identifier: _____

8. APPLICANT INFORMATION:

*a. Legal Name: _____

*b. Employer/Taxpayer Identification Number (EIN/TIN): _____ *c. UEI: _____

d. Address:

*Street 1: _____
Street 2: _____
*City: _____
County/Parish: _____
*State: _____
*Province: _____
*Country: _____
*Zip / Postal Code _____

e. Organizational Unit:

Department Name: _____ Division Name: _____

f. Name and contact information of person to be contacted on matters involving this application:

Prefix: _____ *First Name: _____
Middle Name: _____
*Last Name: _____
Suffix: _____

Title: _____

Organizational Affiliation: _____

*Telephone Number: _____ Fax Number: _____

*Email: _____

Application for Federal Assistance SF-424

***9. Type of Applicant 1: Select Applicant Type:**

Type of Applicant 2: Select Applicant Type:

Type of Applicant 3: Select Applicant Type:

*Other (Specify)

***10. Name of Federal Agency:**

11. Catalog of Federal Domestic Assistance Number:

CFDA Title:

***12. Funding Opportunity Number:**

*Title:

13. Competition Identification Number:

Title:

14. Areas Affected by Project (Cities, Counties, States, etc.):

***15. Descriptive Title of Applicant's Project:**

Attach supporting documents as specified in agency instructions.

Application for Federal Assistance SF-424

16. Congressional Districts Of:

*a. Applicant:

*b. Program/Project:

Attach an additional list of Program/Project Congressional Districts if needed.

17. Proposed Project:

*a. Start Date:

*b. End Date:

18. Estimated Funding (\$):

*a. Federal _____
*b. Applicant _____
*c. State _____
*d. Local _____
*e. Other _____
*f. Program Income _____
*g. TOTAL _____

***19. Is Application Subject to Review By State Under Executive Order 12372 Process?**

- a. This application was made available to the State under the Executive Order 12372 Process for review on _____ .
- b. Program is subject to E.O. 12372 but has not been selected by the State for review.
- c. Program is not covered by E.O. 12372.

***20. Is the Applicant Delinquent On Any Federal Debt?**

Yes No

If "Yes", explain:

21. *By signing this application, I certify (1) to the statements contained in the list of certifications** and (2) that the statements herein are true, complete and accurate to the best of my knowledge. I also provide the required assurances** and agree to comply with any resulting terms if I accept an award. I am aware that any false, fictitious, or fraudulent statements or claims may subject me to criminal, civil, or administrative penalties. (U. S. Code, Title 218, Section 1001)

** I AGREE

** The list of certifications and assurances, or an internet site where you may obtain this list, is contained in the announcement or agency specific instructions.

Authorized Representative:

Prefix: _____ *First Name: _____
Middle Name: _____
*Last Name: _____
Suffix: _____

*Title:

*Telephone Number:

Fax Number:

* Email:

*Signature of Authorized Representative:

Philip F. Calderons

*Date Signed:

Application for Federal Assistance (Development and Equipment Projects)

PART II – PROJECT APPROVAL INFORMATION

Part II - SECTION A			
The term "Sponsor" refers to the applicant name provided in box 8 of the associated SF-424 form.			
Item 1. Does Sponsor maintain an active registration in the System for Award Management (www.SAM.gov)?	Yes	No	
Item 2. Can Sponsor commence the work identified in the application in the fiscal year the grant is made or within six months after the grant is made, whichever is later?	Yes	No	N/A
Item 3. Are there any foreseeable events that would delay completion of the project? If yes, provide attachment to this form that lists the events.	Yes	No	N/A
Item 4. Will the project(s) covered by this request have impacts or effects on the environment that require mitigating measures? If yes, attach a summary listing of mitigating measures to this application and identify the name and date of the environmental document(s).	Yes	No	N/A
Item 5. Is the project covered by this request included in an approved Passenger Facility Charge (PFC) application or other Federal assistance program? If yes, please identify other funding sources by checking all applicable boxes. <div style="margin-left: 20px;"> The project is included in an <i>approved</i> PFC application. If included in an approved PFC application, does the application <i>only</i> address AIP matching share? Yes No </div> The project is included in another Federal Assistance program. Its CFDA number is below.	Yes	No	N/A
Item 6. Will the requested Federal assistance include Sponsor indirect costs as described in 2 CFR Appendix VII to Part 200, States and Local Government and Indian Tribe Indirect Cost Proposals? If the request for Federal assistance includes a claim for allowable indirect costs, select the applicable indirect cost rate the Sponsor proposes to apply: <div style="margin-left: 20px;"> De Minimis rate of 10% as permitted by 2 CFR § 200.414. Negotiated Rate equal to % as approved by (the Cognizant Agency) on (Date) (2 CFR part 200, appendix VII). </div> <i>Note: Refer to the instructions for limitations of application associated with claiming Sponsor indirect costs.</i>	Yes	No	N/A

PART II - SECTION B

Certification Regarding Lobbying

The declarations made on this page are under the signature of the authorized representative as identified in box 21 of form SF-424, to which this form is attached. The term "Sponsor" refers to the applicant name provided in box 8 of the associated SF-424 form.

The Authorized Representative certifies, to the best of his or her knowledge and belief, that:

(1) No Federal appropriated funds have been paid or will be paid, by or on behalf of the Sponsor, to any person for influencing or attempting to influence an officer or employee of an agency, a Member of Congress, an officer or employee of Congress, or an employee of a Member of Congress in connection with the awarding of any Federal contract, the making of any Federal grant, the making of any Federal loan, the entering into of any cooperative agreement, and the extension, continuation, renewal, amendment, or modification of any Federal contract, grant, loan, or cooperative agreement.

(2) If any funds other than Federal appropriated funds have been paid or will be paid to any person for influencing or attempting to influence an officer or employee of any agency, a Member of Congress, an officer or employee of Congress, or an employee of a Member of Congress in connection with this Federal contract, grant, loan, or cooperative agreement, the Authorized Representative shall complete and submit Standard Form-LLL, "Disclosure Form to Report Lobbying," in accordance with its instructions.

(3) The Authorized Representative shall require that the language of this certification be included in the award documents for all sub-awards at all tiers (including subcontracts, subgrants, and contracts under grants, loans, and cooperative agreements) and that all subrecipients shall certify and disclose accordingly.

This certification is a material representation of fact upon which reliance was placed when this transaction was made or entered into. Submission of this certification is a prerequisite for making or entering into this transaction imposed by section 1352, title 31, U.S. Code. Any person who fails to file the required certification shall be subject to a civil penalty of not less than \$10,000 and not more than \$100,000 for each such failure.

PART II – SECTION C

The Sponsor hereby represents and certifies as follows:

1. Compatible Land Use – The Sponsor has taken the following actions to assure compatible usage of land adjacent to or in the vicinity of the airport:

2. Defaults – The Sponsor is not in default on any obligation to the United States or any agency of the United States Government relative to the development, operation, or maintenance of any airport, except as stated herewith:

3. Possible Disabilities – There are no facts or circumstances (including the existence of effective or proposed leases, use agreements or other legal instruments affecting use of the Airport or the existence of pending litigation or other legal proceedings) which in reasonable probability might make it impossible for the Sponsor to carry out and complete the Project or carry out the provisions of the Grant Assurances, either by limiting its legal or financial ability or otherwise, except as follows:

4. Consistency with Local Plans – The project is reasonably consistent with plans existing at the time of submission of this application) of public agencies that are authorized by the State in which the project is located to plan for the development of the area surrounding the airport.

5. Consideration of Local Interest – It has given fair consideration to the interest of communities in or near where the project may be located.

6. Consultation with Users – In making a decision to undertake an airport development project under Title 49, United States Code, it has consulted with airport users that will potentially be affected by the project (§ 47105(a)(2)).

7. Public Hearings – In projects involving the location of an airport, an airport runway or a major runway extension, it has afforded the opportunity for public hearings for the purpose of considering the economic, social, and environmental effects of the airport or runway location and its consistency with goals and objectives of such planning as has been carried out by the community and it shall, when requested by the Secretary, submit a copy of the transcript of such hearings to the Secretary. Further, for such projects, it has on its management board either voting representation from the communities where the project is located or has advised the communities that they have the right to petition the Secretary concerning a proposed project.

8. Air and Water Quality Standards – In projects involving airport location, a major runway extension, or runway location it will provide for the Governor of the state in which the project is located to certify in writing to the Secretary that the project will be located, designed, constructed, and operated so as to comply with applicable and air and water quality standards. In any case where such standards have not been approved and where applicable air and water quality standards have been promulgated by the Administrator of the Environmental Protection Agency, certification shall be obtained from such Administrator. Notice of certification or refusal to certify shall be provided within sixty days after the project application has been received by the Secretary.

PART II – SECTION C (Continued)

9. Exclusive Rights – There is no grant of an exclusive right for the conduct of any aeronautical activity at any airport owned or controlled by the Sponsor except as follows:

10. Land – (a) The sponsor holds the following property interest in the following areas of land, which are to be developed or used as part of or in connection with the Airport subject to the following exceptions, encumbrances, and adverse interests, all of which areas are identified on the aforementioned property map designated as Exhibit “A”. [1]

The Sponsor further certifies that the above is based on a title examination by a qualified attorney or title company and that such attorney or title company has determined that the Sponsor holds the above property interests.

(b) The Sponsor will acquire within a reasonable time, but in any event prior to the start of any construction work under the Project, the following property interest in the following areas of land on which such construction work is to be performed, all of which areas are identified on the aforementioned property map designated as Exhibit “A”. [1]

(c) The Sponsor will acquire within a reasonable time, and if feasible prior to the completion of all construction work under the Project, the following property interest in the following areas of land which are to be developed or used as part of or in connection with the Airport as it will be upon completion of the Project, all of which areas are identified on the aforementioned property map designated as Exhibit “A”. [1]

¹ State the character of property interest in each area and list and identify for each all exceptions, encumbrances, and adverse interests of every kind and nature, including liens, easements, leases, etc. The separate areas of land need only be identified here by the area numbers shown on the property map.

PART III – BUDGET INFORMATION – CONSTRUCTION

SECTION A – GENERAL

1. Assistance Listing Number:
2. Functional or Other Breakout:

SECTION B – CALCULATION OF FEDERAL GRANT

Cost Classification	Latest Approved Amount (Use only for revisions)	Adjustment + or (-) Amount (Use only for revisions)	Total Amount Required
1. Administration expense			
2. Preliminary expense			
3. Land, structures, right-of-way			
4. Architectural engineering basic fees			
5. Other Architectural engineering fees			
6. Project inspection fees			
7. Land development			
8. Relocation Expenses			
9. Relocation payments to Individuals and Businesses			
10. Demolition and removal			
11. Construction and project improvement			
12. Equipment			
13. Miscellaneous			
14. Subtotal (Lines 1 through 13)			
15. Estimated Income (if applicable)			
16. Net Project Amount (Line 14 minus 15)			
17. Less: Ineligible Exclusions (Section C, line 23 g.)			
18. Subtotal (Lines 16 through 17)			
19. Federal Share requested of Line 18			
20. Grantee share			
21. Other shares			
22. TOTAL PROJECT (Lines 19, 20 & 21)			

SECTION C – EXCLUSIONS	
23. Classification (Description of non-participating work)	Amount Ineligible for Participation
a.	
b.	
c.	
d.	
e.	
f.	
g. Total	

SECTION D – PROPOSED METHOD OF FINANCING NON-FEDERAL SHARE	
24. Grantee Share – Fund Categories	Amount
a. Securities	
b. Mortgages	
c. Appropriations (by Applicant)	
d. Bonds	
e. Tax Levies	
f. Non-Cash	
g. Other (Explain):	
h. TOTAL - Grantee share	
25. Other Shares	Amount
a. State	
b. Other	
c. TOTAL - Other Shares	
26. TOTAL NON-FEDERAL FINANCING	

SECTION E – REMARKS (Attach sheets if additional space is required)

PART IV – PROGRAM NARRATIVE
(Suggested Format)

PROJECT:
AIRPORT:
1. Objective:
2. Benefits Anticipated:
3. Approach: (See approved Scope of Work in Final Application)
4. Geographic Location:
5. If Applicable, Provide Additional Information:
6. Sponsor's Representative: (include address & telephone number)

Albany International Airport
Runway 01/19 Pavement Rehabilitation, Runway 01/19 Centerline & Runway 01 TDZ Lighting Rehabilitation, & South Perimeter Road Construction
FAA AIP

PROJECT COST BREAKDOWN												
Item	Description	Work Code / NPR	Admin Cost ^{1, 2, 3}	Engineering ⁴	Inspection ⁵	Construction	Total Cost	% Eligible	FAA Share	NYS Share	Local Share	
									90%	5%	5%	
1	Runway 01/19 Pavement Rehabilitation, Runway 01/19 Centerline & Runway 01 TDZ Lighting Upgrades	Rehabilitate RW 1-19 (8,500' X 150') (Design & Construct) - Including Rehabilitation of Runway Centerline Lights and RW 1 Touchdown Zone Lights, and RW Markings	RE RW IM / 81	\$92,980	\$313,250	\$610,200	\$8,809,790	\$9,826,219	100.0%	\$8,843,598	\$491,311	\$491,311
2	South Perimeter Road Construction	Runway 1 - Construct South Side Perimeter Road (Approx 5,700' X 12') - Design & Construction	SA SV CO / 51	\$124,075	\$0	\$26,745	\$386,135	\$536,956	100.0%	\$483,260	\$26,848	\$26,848
Total				\$217,055	\$313,250	\$636,945	\$9,195,925	\$10,363,175		\$9,326,858	\$518,159	\$518,159
									Proposed AIP Entitlement:		\$6,494,552	
									Proposed AIP Discretionary:		\$2,832,306	

1/ Admin cost under South Perimeter Road Construction includes presumed 1:1 environmental mitigation ratio (\$120,000)
2/ CA Cost apportionment based on construction values between runway rehabilitation cost and perimeter road construction cost
3/ Admin costs include: AGIS field survey, ADIP As-Builts upload, and construction reporting & invoicing
4/ South Perimeter Road design fully ACAA funded
5/ CI Cost apportionment based on construction values between runway rehabilitation cost and perimeter road construction cost

- NOTES:**
1. THE BASE BID INCLUDES THE RUNWAY 01-19 PAVEMENT REHABILITATION IN WORK AREAS D & E (SOUTH OF RUNWAY 10-28) AND THE REPLACEMENT OF ALL RUNWAY CENTERLINE LIGHTS AND TDZ LIGHTS AND ASSOCIATED CIRCUIT HOMERUNS TO THE ELECTRICAL VAULT.
 2. THE ALTERNATE BID INCLUDES THE RUNWAY 01-19 PAVEMENT REHABILITATION IN WORK AREAS A, B, C, D AND E (FULL LENGTH OF THE RUNWAY) AND THE REPLACEMENT OF ALL RUNWAY CENTERLINE LIGHTS AND TDZ LIGHTS AND ASSOCIATED CIRCUIT HOMERUNS TO THE ELECTRICAL VAULT.
 3. ADD-ON 1 INCLUDES THE REPLACEMENT OF ALL THE RUNWAY EDGE LIGHTS AND ASSOCIATED CIRCUIT HOMERUN TO THE ELECTRICAL VAULT. (NOT AIP ELIGIBLE)
 4. ADD-ON 2 INCLUDES THE REHABILITATION OF THE SOUTH SIDE SERVICE ROAD.
 5. SEE SHEET GC100 FOR OVERALL CONSTRUCTION SAFETY PHASING PLAN OF WORK AREAS.

- LEGEND:**
- BASE BID LIMITS
 - + ALTERNATE BID LIMITS
 - ADD-ON 1 LIMITS
 - ADD-ON 2 LIMITS

C1 BID NOTES
SCALE: NOT TO SCALE

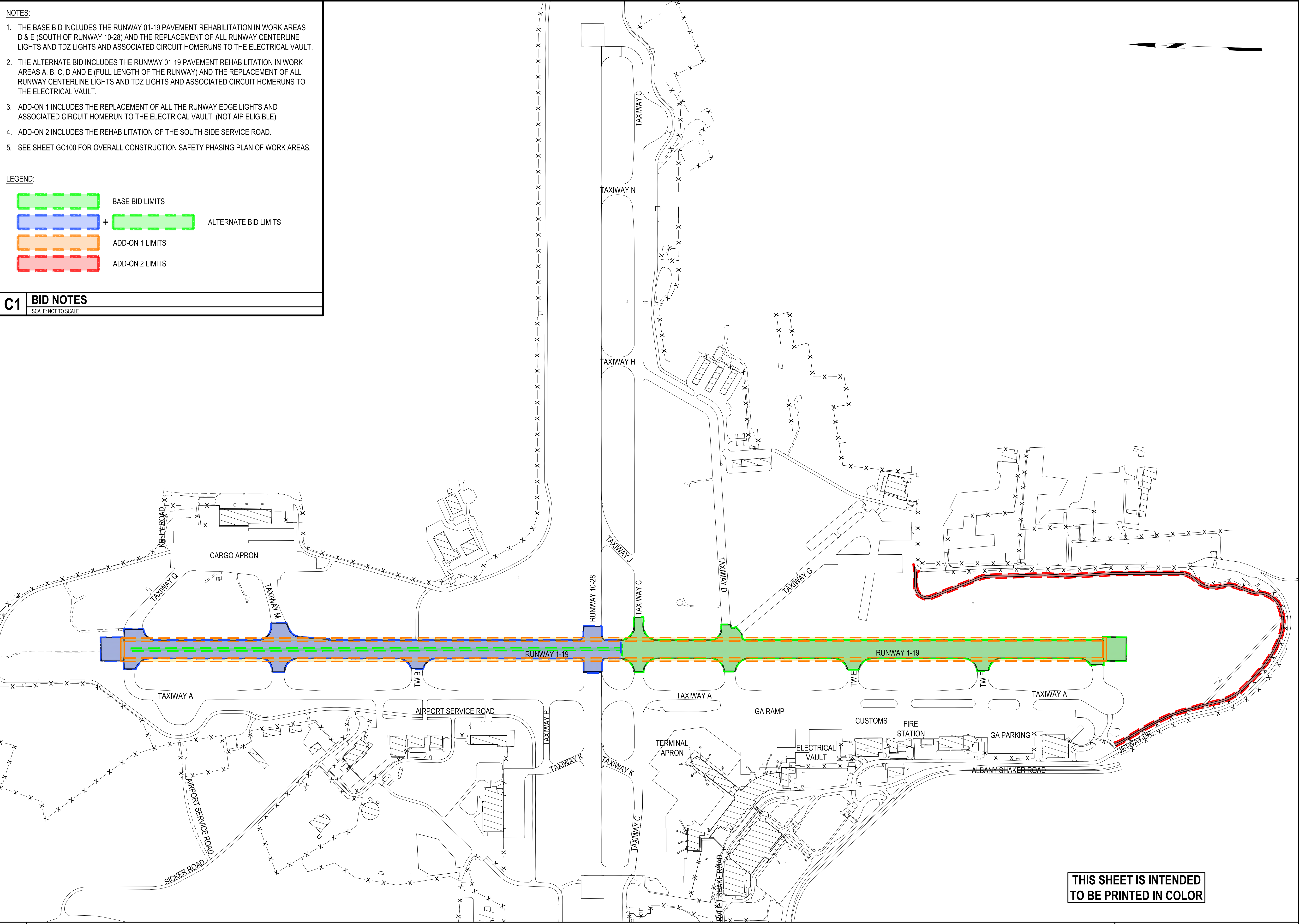

C&S Engineers, Inc.
41 State Street, Suite 600
Albany, New York 12207
Phone: 518-915-7349
www.cscos.com



**RUNWAY 01-19 REHABILITATION
AND LIGHTING UPGRADES**
**ALBANY INTERNATIONAL AIRPORT
COLONIE, NEW YORK**

MARK	DATE	DESCRIPTION
REVISIONS		
PROJECT NO: Q23014001		
DATE: FEBRUARY 2024		
DRAWN BY: M.D. HERNANDEZ		
DESIGNED BY: R.J. KOLLER		
CHECKED BY: C.D. BRUBACH		

NO ALTERATION PERMITTED HEREON EXCEPT AS PROVIDED UNDER SECTION 7209 SUBDIVISION 2 OF THE NEW YORK EDUCATION LAW

SCOPE OF WORK PLAN

GI101

THIS SHEET IS INTENDED TO BE PRINTED IN COLOR

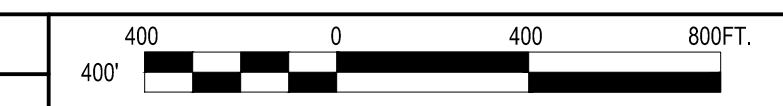

Feb 16, 2024, 1:22:40pm P:\Projects\Q23 - Albany County Airport Albany\Q23014001 - R10Y 1-9 Rehab\Design\A03\Sheet Files\Q23014001_GI101.dwg

A1 SCOPE OF WORK PLAN
SCALE: 1"=400'



United States
Department of
Agriculture

Animal and
Plant Health
Inspection
Service

Wildlife Services

572 Third Ave Ext.
Suite 2
Rensselaer, NY
12144

September 18, 2023

Subject: USDA's support for FY24 south perimeter road project at Albany International Airport (ALB)

To whom it concerns,

USDA Wildlife Services (WS) would like to express support for the proposed perimeter road project at the southern end of the airfield. WS has been a long withstanding cooperator with ALB that was primarily contracted to provide a yearlong comprehensive Wildlife Hazard Assessment (2008), to participate in annual reviews of the Wildlife Hazard Management Plan, and to conduct continued monitoring and hazardous wildlife management on and off the airfield.

After years of continued monitoring and examination of the habitat in the proposed project location, WS determined this area to be a significant wildlife attractant to several hazardous bird and mammal species given the amount of food, water, and cover present. Canada geese are a primary species observed in this location, and rank fourth on the list of hazardous wildlife species (Advisory Circular 150/5200 32B). Additionally, several carcasses were recovered in this area after geese were struck by an aircraft during 2019, causing substantial damage.

The Code of Federal Regulations under Part 139.337-Wildlife hazard management; states that "...each certificate holder must take immediate action to alleviate wildlife hazards whenever they are detected." Construction of a perimeter road at this location would enhance wildlife management efforts for the following reasons:

- Ease of accessibility
- Improved detectability
- Prompt mitigation
- Increase effectiveness to monitor wildlife ingress points along security fence
- Capability of conducting surveillance to determine wildlife trends

Thank you for the opportunity to express support for this project. We are confident that if this project proceeds, it will improve aviation safety at Albany International Airport.

Shaun Story

Wildlife Specialist
USDA APHIS Wildlife Services
(518) 419-1463
shaun.j.story@usda.gov



Safeguarding American Agriculture
APHIS is an agency of USDA's Marketing and Regulatory Programs
An Equal Opportunity Provider and Employer



**Transportation
Security
Administration**

U.S. Department of Homeland Security
Albany International Airport
737 Albany Shaker Road
Albany, NY 12211



September 11, 2023

Mr. Connor Haskin
Chief Airport Planner
Albany International Airport
737 Albany Shaker Road
Albany, New York 12211

Dear Mr. Haskin:

Reference is made to your written request on September 6, 2023, to provide the Albany International Airport (ALB) comments for the proposed plan of expanding the service road on the south end of the Air Operations Area (AOA) to complete the circuit road.

As a result of your request I have consulted with the staff of the Transportation Security Administration ALB offices and we believe that your proposed plan would enhance security and emergency response.

If you require anything further, please do not hesitate to contact me.

Sincerely,

A handwritten signature in blue ink is located below the word "Sincerely,". The signature appears to read "B. Johnson" and is written in a cursive style.

Bart R. Johnson
Federal Security Director

June 24, 2024

Mr. John LaClair, P.E., G.G.P.
Albany County Airport Authority (ACAA)
Albany International Airport
Terminal Bldg. Administration Offices, 3rd floor
Albany, NY 12211

Re: Runway 01-19 Rehabilitation & Lighting Upgrades Project
Albany International Airport
Recommendation of Award Letter
Contract # 1162-GC

File: Q23.014.001

Dear Mr. LaClair:

Two bids for the above referenced project were received on or prior to June 20, 2024 at 11:00am. The bids were opened by the Albany County Airport Authority. The bids were tabulated by C&S Engineers, Inc. The low bidder is as follows:

<u>CONTRACTOR</u>	<u>BID AMOUNT</u>
Callanan Industries, Inc.	Base: \$5,210,355.00
PO Box 15097	Alternate: \$8,809,790.00
Albany, NY 12212	Add-on #1: \$296,575.00
Mr. Michael Mastropietro (Vice President)	Add-on #2: \$386,135.00
P: (518)-374-2222	
estimating@callanan.com	

The low bid was reviewed by C&S Engineers, Inc. and found to be in order. For a complete breakdown of the bid amounts and the remaining bidders, please refer to the attached bid tabulation.

We have verified that the low bidder is not on the NYSDOL List of Debarred Contractors. Callanan Industries, Inc. status is listed as active and current on the NYS Department of State Division of Corporations Entity Information database.

The low Base bid submitted is 30.9% below the Engineer's Opinion of Construction Cost for the project. The low Alternate bid submitted is 27% below the Engineer's Opinion of Construction Cost. The low Add-on #1 bid submitted is 1.3% above the Engineer's Opinion of Construction Cost. The low Add-on #2 submitted is 65% below the Engineer's Opinion of Construction Cost.

The bids are considered reasonable based on the other bids received. A major cost savings can be attributed to Addendum #1 which allows for a continuous 7-day runway closure to facilitate the work. The engineer's estimate was based on nightly segmental work.

Callanan Industries, Inc. has completed multiple projects at Albany International Airport and is deemed qualified for this work. Qualifications were submitted with their bid proposal and appear to be in order.

Callanan Industries, Inc. is not a certified DBE firm. It is our understanding that the ACAA will request the bidder's DBE plan which must be reviewed and approved prior to entering a contract.

Based on our review of information submitted and consultation with the ACAA, we recommend award of the contract Alternate Bid with add-ons #1 & 2 in the amount of \$9,492,500.00 to Callanan Industries, Inc. in accordance with the conditions of award stipulated in their bid and contingent upon Federal Aviation Administration concurrence. Please be advised that Add-on #2 for replacement of the Runway edge lights with LED fixtures is not FAA AIP eligible due to the fact that the existing lights have not met their 10-year life expectancy.

If you agree with our recommendation of award, please take appropriate ACAA board approval actions and issue Callanan Industries, Inc. a Notice of Award letter. Please contact us should you disagree with our recommendation and decide not to award to Callanan Industries, Inc. We will be happy to discuss your options within the Contract Documents.

If you have any questions or need additional information, please do not hesitate to contact me.

Very truly yours,

C&S ENGINEERS, INC.



Christopher D. Brubach, P.E.
Senior Principal Engineer

Enclosures

Department of State

Division of Corporations

Entity Information

[Return to Results](#)[Return to Search](#)

Entity Details



ENTITY NAME: CALLANAN INDUSTRIES, INC.
DOS ID: 314036
FOREIGN LEGAL NAME:
FICTITIOUS NAME:
ENTITY TYPE: FOREIGN BUSINESS CORPORATION
DURATION DATE/LATEST DATE OF DISSOLUTION:
SECTION OF LAW: -
ENTITY STATUS: ACTIVE
DATE OF INITIAL DOS FILING: 09/07/1971
REASON FOR STATUS:
EFFECTIVE DATE INITIAL FILING: 09/07/1971
INACTIVE DATE:
FOREIGN FORMATION DATE: 08/17/1971
STATEMENT STATUS: CURRENT
COUNTY: ALBANY
NEXT STATEMENT DUE DATE: 09/30/2025
JURISDICTION: DELAWARE, UNITED STATES
NFP CATEGORY:

[ENTITY DISPLAY](#)[NAME HISTORY](#)[FILING HISTORY](#)[MERGER HISTORY](#)[ASSUMED NAME HISTORY](#)

Service of Process on the Secretary of State as Agent

The Post Office address to which the Secretary of State shall mail a copy of any process against the corporation served upon the Secretary of State by personal delivery:

Name: C/O CORPORATION SERVICE COMPANY

Address: 80 STATE STREET, ALBANY, NY, UNITED STATES, 12207

Electronic Service of Process on the Secretary of State as agent: Not Permitted

Chief Executive Officer's Name and Address

Name: DONALD FANE

Address: 8 SOUTHWOODS BLVD., 4TH FLOOR, ALBANY, NY, UNITED STATES, 12211

Principal Executive Office Address

Address: 8 SOUTHWOODS BLVD., 4TH FLOOR, ALBANY, NY, UNITED STATES, 12211

Registered Agent Name and Address

Name: CORPORATION SERVICE COMPANY

Address: 80 STATE STREET, ALBANY, NY, 12207 - 2543

Entity Primary Location Name and Address

Name:

Address:

Farmcorpflag

Is The Entity A Farm Corporation: NO

Stock Information

Share Value

Number Of Shares

Value Per Share



90 East Avenue • Saratoga Springs, NY 12866
Phone: (518) 580-9380
www.mjinc.com

June 24th, 2024

Mr. John LaClair, P.E., G.G.P.
Chief Engineer
Albany County Airport Authority
Albany International Airport
Terminal Bldg. Administration Offices, 3rd floor
Albany, NY 12211

Re: Runway 01-19 Rehabilitation & Lighting Upgrades Project, Recommendation of Award Letter

Dear Mr. LaClair:

McFarland Johnson, Inc. (MJ) has reviewed the bid tabulations and recommendation to award tabulated by C&S Engineers, Inc. As the designer of record for Add-on #2, MJ is in agreement with the award of Add-on #2 to Callanan Industries, Inc. PO Box 15097, Albany, NY 12212 in the amount of \$386,135.00. If you have any questions or require anything further, please let me know.

Regards,

Turner Bradford

Turner Bradford, PE
Senior Engineer



July 1st, 2024
By electronic transmittal

Mr. Ralph Gatto, Airport Engineer
FAA New York Airports District Office
One Aviation Plaza, Suite 111
Jamaica, New York 11434

Re: Concurrence in Award Request: Runway 01/19 Pavement Rehabilitation, Runway 01/19 Centerline & Runway 01 TDZ Lighting Upgrades, & South Perimeter Road Construction: Contract 1162-GC Bid Package

Dear Mr. Gatto:

I am writing to respectfully request concurrence in award for the construction Contract 1162-GC to Callanan Industries, Inc. with the following accepted bid pricing:

- ~~Lump Sum Bid: \$5,210,355 (Partial Runway Rehab, *Alternate Bid Accepted*)~~
- Alternate Bid (Full Runway Rehab): \$8,809,790
- Add-On 1 (Runway Edge Lighting): \$296,575 (*Ineligible for FAA funding*)
- Add-on 2 (South Perimeter Road Construction): \$386,135
 - **Total Accepted Bid: \$9,492,500**

Enclosed please find the certified bid tab, and pre-bid attendance list for your reference. The Alternate Bid was accepted over the Lump Sum Bid due to the indicated availability of federal funding to complete the full runway rehabilitation in a single fiscal year.

Please extend our gratitude to your staff for the excellent assistance associated with our capital improvement projects. Please do not hesitate to call Connor Haskin on my staff at (518) 242-2239 if you require any additional information or assistance.

Sincerely,

Philip F. Calderone

Philip F. Calderone, Esq.,
Chief Executive Officer

cc: Rob Costa, FAA NYADO
Christine Quinn, ACAA
Michael Zonsius, ACAA
John LaClair, ACAA
Margaret Herrmann, ACAA
Connor Haskin, ACAA

CONTRACT #1162-GC
Runway 01-19 Rehabilitation and Lighting Upgrades

Company Name	Callanan Industries, Inc.	Rifenburg Construction, Inc.
Addendums #1-4	X	X
Total Unit Price Bid	\$5,210,355.00	\$6,228,115.00
Alternate Bid	\$8,809,790.00	\$10,606,115.00
Add-On 1	\$296,575.00	\$390,000.00
Add-On 2	\$386,135.00	\$709,000.00
Bid Bond	5%	5%
Board of Directors	X	X
Non-Collusion	X	X
Qualification Questionnaire	X	X
Acknowledgment	X	X

I, Katie Kane, certify that this bid tabulation is a true copy of the prices submitted by each bidder for the construction project shown above.

Albany Airport Authority Purchasing Department

 Katie Kane
 Deputy Purchasing Agent

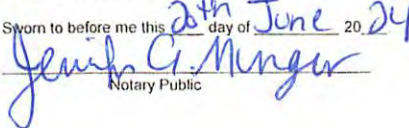
Sworn to before me this 20th day of June, 2024

 Notary Public

JENNIFER A. MUNGER
 Notary Public, State of New York
 No. 01MU6246332
 Qualified in Schenectady County
 Commission Expires Aug. 08, 2027



Pre-Bid Meeting
Contract # 1162-EC

5/30/24
11:00 AM

Company	Name	Phone #	Email
RIFENBURG CONSTRUCTION, INC	MATT TOZZI	518-279-3265	MTOZZI@RIFENBURG.COM
RIFENBURG CONSTRUCTION	DAN FILUTA	518-279-3265	DFILUTA@RIFENBURG.COM
EATON CREWS - HIAS	Jim Teixeira	631-901-4885	jimdteixeira@ eaton.com
Zach Hestke			
Callanan Ind.	Zach Hestke	518-275-6727	estimating@ callanan.com
DCC ELECTRIC	Gerry Nide	518-385-6164	gnide@dcelectric. NET



June 28th, 2024

By electronic transmittal

Mr. Ralph Gatto, Airport Engineer
FAA New York Airports District Office
One Aviation Plaza, Suite 111
Jamaica, New York 11434

Re: Request for Reimbursement of Eligible Runway 1-19 Rehabilitation & Lighting Upgrade Design Service Costs

Dear Mr. Gatto:

I am writing to respectfully request reimbursement of design service expenses as related to the Runway 1-19 Rehabilitation & Lighting Upgrade project included under the associated AIP grant application. It is understood that design costs are eligible for reimbursement under the category of project formulation related to the specific project.

I have included the original October 2023 design services agreement between Albany County Airport Authority and C&S Engineers, Inc. The reimbursable amount is estimated to be \$313,250.00. Additional documentation and invoices can be provided as requested.

Please extend our gratitude to your staff for the excellent assistance associated with our capital improvement projects. Please do not hesitate to call Chief Airport Planner, Connor Haskin of my staff at (518) 242-2239 if you require any additional information or assistance.

Sincerely,

Philip F. Calderone

Philip F. Calderone, Esq.,
Chief Executive Officer

cc: Rob Costa, FAA NYADO
Christine Quinn, ACAA
Michael Zonsius, ACAA
John LaClair, ACAA
Margaret Herrmann, ACAA
Connor Haskin, ACAA

**PROFESSIONAL SERVICES AGREEMENT
BETWEEN THE**

**ALBANY COUNTY AIRPORT AUTHORITY
AND
C&S ENGINEERS, INC.**

**FOR THE
RUNWAY 01-19 REHABILITATION AND
LIGHTING UPGRADES**

AT THE ALBANY INTERNATIONAL AIRPORT

CONTRACT NO. S-1162

THIS AGREEMENT is made and entered into effective the 30th day of October, 2023, by and between the **ALBANY COUNTY AIRPORT AUTHORITY** (the "Authority"), a body corporate and politic constituting a public benefit corporation established and existing pursuant to the Albany County Airport Authority Act enacted by Chapter 686 of the laws of 1993 and set forth in Title 32 of the New York Public Authorities Law, having offices at the Albany International Airport, 737 Albany Shaker Road, Main Terminal, 3rd Floor, Albany, NY, 12211 and C&S Engineers, Inc., (the "Consultant"), a **New York Corporation** having its office and principal place of business at 499 Col. Eileen Collins Boulevard, Syracuse, New York 13212.

RECITALS

1. The County of Albany (the "County") is the owner of the Albany International Airport (the "Airport"), located in the Town of Colonie, County of Albany, State of New York.
2. The County and the Authority have entered into an Airport Lease Agreement, effective as of May 16, 1996, for a term expiring December 31, 2049, whereby the AUTHORITY has the exclusive right to operate, maintain and improve the Airport and do anything else permitted by law, subject only to the restrictions and conditions stated in such Airport Lease Agreement and in accordance with applicable law.
3. The Consultant has heretofore submitted a proposal, dated September 26, 2023, for the project entitled Runway 01-19 Rehabilitation and Lighting Upgrades.
4. The Authority has negotiated a scope of work with the Consultant as described herein.
5. This Agreement had been duly authorized by the Albany County Airport Authority by resolution adopted on October 11, 2023.

NOW THEREFORE, in consideration of the mutual covenants contained herein, the parties hereto agree as follows:

ARTICLE I - SERVICES TO BE PERFORMED

The Consultant shall perform the services hereinafter set forth under Article II, entitled "Scope of Work" during the period from execution of this Agreement until completion of the work, as described in Article XIII, hereof.

ARTICLE II - SCOPE OF WORK

The Authority agrees to and hereby does retain and employ the service of the Consultant because of its ability and reputation, and the Consultant agrees to perform such service of said project being particularly described in the Scope of Work, attached as SCHEDULE "A" hereto, and made a part hereof.

ARTICLE III - FEES

In consideration of the terms and obligations of this Agreement, the Authority agrees to pay and the Consultant agrees to accept as full compensation for all services rendered under this Agreement those costs for work actually performed in accordance with the "Fee Schedule" attached as SCHEDULE "B" hereto, and made a part hereof.

Consultant's fees in the aggregate shall not exceed \$313,250.00.

Payment of fees shall be made upon proper completion of a Claim Form by the Consultant. The Claim Form is set forth at the end of Schedule "B", Fee Schedule. Payment by the Authority to the Consultant shall be due and payable within thirty (30) days of receipt of a complete, accurate and acceptable Claim Form by the Authority. The Authority shall retain five percent (5%) of each payment until 100% completion of the work by Consultant. Upon completion of 100% of the work by the Consultant, and acceptance of such work by the Authority, the Consultant shall be entitled to any amounts retained by the Authority hereunder.

ARTICLE IV - AVAILABLE DATA

All technical or other data relative to the work in the possession of the Authority or in possession of the Consultant shall be made available to either party without expense.

ARTICLE V - COOPERATION

The Consultant shall cooperate with representatives, agents and employees of the Authority and the Authority shall cooperate with the Consultant to the end that work may proceed expeditiously and economically.

ARTICLE VI - EXTRA WORK

If the Consultant is of the opinion that any work the Consultant has been directed to perform is beyond the scope of this Agreement and constitutes Extra Work, the Consultant shall promptly notify the Authority in writing of the fact. The Authority shall be the sole judge as to whether or not such work is in fact beyond the scope of this Agreement and whether or not it constitutes Extra Work. In the event that the Authority determines in writing that such work does constitute Extra Work, it shall provide extra compensation to the Consultant on a negotiated basis.

ARTICLE VII - ACCOUNTING RECORDS

Proper and full accounting records shall be maintained by the Consultant, which records shall clearly identify the costs of the work performed under this Agreement. Such records shall be subject to periodic and final audit by the Authority upon request. Such records shall be accessible to the Authority for a period of six (6) years following the date of final payment by the Authority to the Consultant for the performance of the work contemplated herein.

ARTICLE VIII - ASSIGNMENTS

The Consultant specifically agrees as required by Section 109 of the New York General Municipal Law that the Consultant is prohibited from assigning, transferring, conveying, sub-contracting, or otherwise disposing of this Agreement, or of Consultant's right, title or interest therein without the previous consent, in writing, of the Authority.

ARTICLE IX - OWNERSHIP OF MATERIALS

All rights, titles and ownership in and to all materials prepared under the provision of this Agreement shall be in the Authority including the right of republication.

ARTICLE X - INDEPENDENT CONTRACTOR

The Consultant, in accordance with its status as an independent contractor, covenants and agrees that it will conduct itself consistent with such status, that it will neither hold itself out as, nor claim to be an agent, employee, or otherwise of the Authority by reason hereof, and that it will not, by reason hereof, make for itself, its representatives, or employees, any claim, demand or application to or for any right or privilege applicable to an agent, employee, or otherwise of the Authority, including, but not limited to Workman's Compensation coverage, Unemployment Insurance benefits, Social Security coverage, or Retirement membership or credit.

ARTICLE XI - INDEMNIFICATION

The Consultant shall indemnify and save harmless the Authority, its employees and agents, including the County of Albany, the Federal Aviation Administration, the State of New York and AFCO AvPorts Management, LLC, from and against all claims, damages, losses and expenses (including, without limitation, reasonable attorney's fees) arising out of, or in consequence of, any negligent act or omission or intentional act of the Consultant, to the extent of their responsibility for such claims, damages, losses and expenses and to the fullest extent as possible by law.

ARTICLE XII - INSURANCE

The CONSULTANT shall procure and maintain at its own expense and without direct expense to the AUTHORITY until final acceptance by the AUTHORITY of the services covered by this Agreement, insurance policies of the kinds and the amounts hereafter provided, issued by insurance companies **licensed** by New York State and having an **A.M. Best rating of "A" or better**, covering all operations under this Agreement, whether performed by the CONSULTANT or by sub-contractors. Before commencing the work, the CONSULTANT shall furnish the AUTHORITY a certificate or certificates, in a form satisfactory to the AUTHORITY, showing that it has complied with these requirements, which certificate or certificates shall provide that the policies shall be automatically renewed and not be materially changed or canceled until thirty (30) days' written notice has been mailed to the AUTHORITY. Certificates which contain a provision or reservation in the cancellation clause that the issuing company will "endeavor to" mail thirty (30) days notice to the certificate holder, "but failure to

mail such notice shall impose no obligation or liability of any kind upon the company, its agents or representatives," or similar conditional notice of cancellation provisions, will not be accepted by the AUTHORITY.

- (a) The kinds and amounts of insurance required are as follows: (CONSULTANT'S sub-contractors and subconsultants shall procure and maintain the same insurance as applicable.)

1. Workers' Compensation and Employers Liability Insurance: A policy or policies providing protection for Employees of the CONSULTANT or subcontractor in the event of job-related injuries as required by law.

Coverage A:	Statutory		
Coverage B:	Bodily Injury by Accident	\$1,000,000	each accident
	Bodily Injury by Disease	\$1,000,000	policy limit
	Bodily Injury by Disease	\$1,000,000	each employee

2. Automobile Liability Policies including coverage for any owned automobile(s), hired automobile(s) and non-owned automobile(s), shall be furnished with limits of not less than:

Liability For Bodily Injury & Property Damage Combined Single Limit	\$5,000,000
--	-------------

3. General Liability Insurance: Commercial General Liability (Occurrence Form) including contractual, personal injury, premises/products and completed operations liability, explosion, collapse and underground and broad form property damage and shall cover all operations and shall be furnished with limits of not less than:

Liability For Bodily Injury & Property Damage Combined Single Limit	\$5,000,000
--	-------------

The general liability insurance required must include contractual liability insurance applicable to CONSULTANT'S obligations under this Agreement. Provide a list of all endorsed exclusions, if any. CONSULTANT shall maintain products/completed operations coverage for the duration of this Agreement and for a minimum of three years after completion of all services covered by this Agreement

4. Professional Liability Insurance: CONSULTANT shall maintain a Professional Liability policy throughout the duration of this Agreement and agrees to maintain the policy for a minimum of three years after completion of all services covered by this Agreement.

Limit	\$5,000,000 Each Claim
-------	------------------------

If the policy has an annual aggregate limit, CONSULTANT shall immediately notify the AUTHORITY of any and all claims which have or may be charged against such limit.

The above specified limits may be met through either primary or excess coverage

policies, provided that any excess coverage is written on a following form basis and it is at least as broad as the underlying policies and that any deductible or retention amount does not exceed \$25,000 or 10% (in total), whichever is less, of the required liability limits. The AUTHORITY may accept policies with coverage, exclusions or liability limits different than those specified above when such policies, in the sole judgment of the AUTHORITY, will provide satisfactory protection to the AUTHORITY.

The policies specified above, except for Professional Liability, Workers' Compensation and Disability Benefits, shall be endorsed to include the **ALBANY COUNTY AIRPORT AUTHORITY AND ITS AGENT, AFCO AVPORTS MANAGEMENT, LLC, THE COUNTY OF ALBANY, THE FEDERAL AVIATION ADMINISTRATION, and THE STATE OF NEW YORK**, and any other substituted or additional agents the AUTHORITY may hire, as additional insureds, as respects services performed by the CONSULTANT and all policies shall include a provision restricting the right of the insurer to cancel or materially change such coverage except upon thirty days' written notice to AUTHORITY. Certificates evidencing the coverage of the additional insureds a copy of the policy endorsement that adds the requested entities as Additional Insureds, or that section of the General Liability policy that provides for automatic coverage for Additional Insureds when it is required under the terms of a written contract shall be delivered to AUTHORITY prior to performing any services under this Agreement.

If the Project involves on-site construction-phase services by the CONSULTANT, construction contractors shall be required to provide (or AUTHORITY may provide) Owner's Protective Liability insurance naming the **ALBANY COUNTY AIRPORT AUTHORITY, AND ITS AGENT, AFCO AVPORTS Management, LLC, THE COUNTY OF ALBANY, THE FEDERAL AVIATION ADMINISTRATION, and THE STATE OF NEW YORK** and any other substituted and additional consultants the AUTHORITY may retain as named insureds and the CONSULTANT as an additional insured on the construction contractor's liability insurance policies covering claims for personal injuries and property damage.

- (b) The policy or policies covering the obligations of the CONSULTANT, set forth in subparagraph (a)(1) above, shall be in accordance with the provisions of any applicable Workers' Compensation or Disability Benefits Law, including for the State of New York, Chapter 41, Laws of 1914, as amended, known as the Workers' Compensation Law, and amendments thereto, and Chapter 600 of the Laws of 1949, as amended, known as the Disability Benefits Law. This Agreement shall be void and of no effect unless the CONSULTANT procures such policy or policies and maintains the same in force during the term of this Agreement.
- (c) If AUTHORITY has any objection to the coverage afforded by or other provisions of the insurance required to be purchased and maintained by CONSULTANT in accordance with paragraph (a) on the basis of its not complying with this Agreement, the AUTHORITY will notify CONSULTANT in writing thereof within thirty (30) days of the date of delivery of such certificates to the AUTHORITY. CONSULTANT will provide such additional information in respect of insurance provided by CONSULTANT as the AUTHORITY may reasonably request. Failure of AUTHORITY to give any such notice of objection within the time provided shall constitute acceptance of such insurance as carried by the CONSULTANT as complying with this Agreement.

ARTICLE XIII - TERMINATION OF CONTRACT

The Parties agree that the service set forth under Article II - "Scope of Work" of this Agreement shall commence upon execution of the Agreement and will continue in effect until completed.

The Authority shall have the right at any time to terminate this Agreement without cause, provided that thirty (30) days written notice of such termination is given in advance by the party terminating the contract. In the event this Agreement is terminated, the Consultant shall be entitled to full compensation, as allowed for herein, for all work previously authorized and performed pursuant to this Agreement. This Agreement can be terminated on twenty-four (24) hours written notice or termination for cause and compensation to Consultant will be on quantum merit less any backcharges or damages sustained or to be sustained by the Authority.

Suspension or Termination of Performance

- (A) Authority may at any time, and for any reason, direct Consultant to stop Consultant's services under this agreement for a period of time. This direction must be in writing and must specify the period during which the services are to be stopped. Consultant shall resume services on the date specified in the direction, or on any other date owner subsequently specifies in writing. The period during which services are stopped is deemed to be added to the time fixed for performance. Stoppage of services under this Section shall not give rise to any claim against owner.
- (B) In the event that:
- (a) For any reason or through any cause, consultant fails to complete performance within the time fixed for performance under this agreement;
 - (b) Grounds for cancellation of the agreement under this section arise;
 - (c) Consultant otherwise defaults under this agreement;
 - (d) Authority gives consultant written notice that in its opinion, the conduct of consultant is such that the interests of owner are likely to be impaired or prejudiced, stating the facts on which the opinion is based; then authority may, on written notice to consultant, immediately terminate this agreement for cause.
- (C) Nothing in this Section is to be construed to relieve consultant from any liability and/or damages sustained by authority as a result of any breach by consultant of this agreement, and payment by authority to consultant of any monies pursuant to this section does not bar owner from any and all remedies it may otherwise have against consultant for any failure of consultant to perform its services in accordance with this agreement.
- (D) Authority is not required to pay consultant under this section until consultant has satisfactorily completed the services required to be performed to the agreed point of suspension or termination.
- (E) Payment by owner to consultant of any monies pursuant to this Section does not bar owner from any and all remedies it may otherwise have against consultant for any failure of consultant to perform its services in accordance with this agreement.
- (F) If this agreement is terminated for any reason, consultant, prior to any payment to consultant pursuant to this section, shall deliver to authority the complete set of all original drawings prepared to the date of termination. Authority is entitled to use the ideas and designs contained in this agreement for the completion of the project; in the event of termination of this agreement or upon completion of the project, authority may, at all times, retain the originals of all such drawings, originals of renderings, special art work, or models. All drawings, plans, specifications, rendering and models,

etc. are the property of authority. They are not to be used by any person other than authority on other projects unless expressly authorized by owner. Consultant is not responsible for any work that has not been completed as of the date of termination under this agreement.

ARTICLE XIV - DELIVERY OF RECORDS

In the event of the termination of this Agreement, as provided in ARTICLE XIII, hereof, all data and records pertaining to the Agreement shall be delivered within twenty (20) days to the Authority or its duly authorized representative. In case of failure of the Consultant to make such delivery on demand, then and in that event, the Consultant shall be liable to the Authority for any damages it may sustain by reason thereof.

ARTICLE XV - DISSOLUTION

In the event of dissolution of the Consultant during the existence of this Agreement, the Consultant shall give thirty (30) days' notice in writing to the Authority in advance of such dissolution.

ARTICLE XVI - LICENSES

The Consultant shall at all times obtain and maintain all licenses required by New York State to perform the services required under this Agreement.

ARTICLE XVII - NON-DISCRIMINATION REQUIREMENT

In accordance with Article 15 of the Executive Law (also known as the Human Rights Law) and all other State and Federal Statutory and constitutional non-discrimination provisions, the Consultant agrees that it shall not, by reason of race, creed, color, national origin, age, sex or disability: (a) discriminate in hiring against any person who is qualified and available to perform the work; or (b) discriminate against or intimidate any employee hired for the performance of work under this Agreement.

ARTICLE XVIII - NON-APPROPRIATIONS CLAUSE

Notwithstanding anything contained herein to the contrary, no default shall be deemed to occur in the event no funds or insufficient funds are appropriated and budgeted by or are otherwise unavailable to the Authority for payment, the Authority will immediately notify the Consultant of such occurrence and this Agreement shall terminate on the last day of the fiscal period for which appropriations were received without penalty or expense to the Authority of any kind whatsoever, except as to those portions herein agreed upon for which funds shall have been appropriated and budgeted.

ARTICLE XIX - APPLICABLE LAW

This Agreement shall be construed for all purposes under the laws of the State of New York. Any litigation pursuant to this Agreement shall be in the Supreme Court of the State of New York in the County of Albany.

ARTICLE XX – MANDATORY FEDERAL CONTRACT PROVISIONS

Federal laws and regulations prescribe that certain provisions be included in certain contracts. The provisions set forth in Appendix B are attached hereto and made a part hereof.

ARTICLE XXI - NOTICE

All notices and documents required to be given or made by the Consultant pursuant to this Agreement shall be given or made to:

Albany County Airport Authority
Chief Executive Officer
Albany International Airport
737 Albany Shaker Road
Main Terminal, 3rd Floor
Albany, NY 12211

All notices and documents to be given or made by the Authority pursuant to this Agreement shall be given or made to:

C&S Engineers, Inc.
499 Col. Eileen Collins Blvd.
Syracuse, New York 13212

ARTICLE XXII - INVALID PROVISIONS

It is further expressly understood and agreed by and between the parties hereto that in the event any covenant, condition or provision herein contained is held to be invalid by any court or competent jurisdiction, the invalidity of such covenant, condition or provision shall in no way affect any other covenant, condition or provision herein contained; provided, however, that the invalidity of any such covenant, condition or provision does not materially prejudice either Authority or Consultant in their respective rights and obligations contained in the valid covenants, conditions or provisions in this Agreement.

IN WITNESS WHEREOF, this Agreement has been executed by the Authority, acting by and through the Chairman of the Authority, and the Consultant, by and through a duly authorized officer has executed this Agreement effective the day and year first above written. The Authority and Consultant agree to delivery by facsimile or by electronic transmission in portable document format (PDF) of an executed original of this Agreement is as effective as delivery of an originally executed Agreement.

ALBANY COUNTY AIRPORT AUTHORITY

BY: 
Samuel A. Fresina
Chairman
Or
Philip F. Calderone, Esq.
Chief Executive Officer

C&S ENGINEERS, INC.

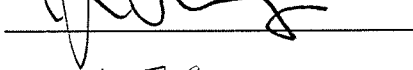
BY: 
John T. Camp
Sen. Vice President

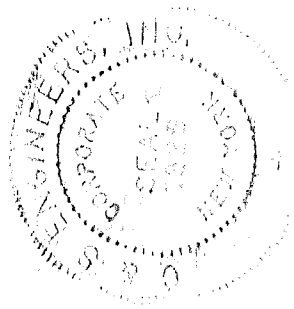

STATE OF NEW YORK)
) ss.:
COUNTY OF ALBANY)

On the _____ day of _____, 20____, before me personally appeared Samuel A. Fresina, to me known, to be the person who executed the above instrument, who, being duly sworn, did depose and say that he resides in the County of Albany, that he is the Chairman of the Albany County Airport Authority, the public benefit corporation described in, and which executed the foregoing instrument in the name of the Albany County Airport Authority pursuant to a resolution adopted by the Albany County Airport Authority on October 11, 2023; and that he signed his name thereto by like authorization.

Notary Public

STATE OF NEW YORK)
) ss.:
COUNTY OF ALBANY)

On the 30th day of October, 2023, before me personally appeared Philip F. Calderone, Esq., to me known, to be the person who executed the above instrument, who, being duly sworn, did depose and say that he resides in the County of Albany, that he is the Chief Executive Officer of the Albany County Airport Authority, the public benefit corporation described in, and which executed the foregoing instrument in the name of the Albany County Airport Authority pursuant to a resolution adopted by the Albany County Airport Authority on October 11, 2023; and that he signed his name thereto by like authorization.

Jennifer A. Munger
Notary Public

STATE OF _____)
) ss.:
COUNTY OF _____)

JENNIFER A. MUNGER
Notary Public, State of New York
No. 01MU6246332
Qualified in Schenectady County
Commission Expires Aug. 08, 2027

On this ____ day of _____, 20__ before me personally came _____, to me known, who being by me duly sworn, did depose and say that he/she resides in _____ County, that he/she is the _____ of _____, the LLC described in, and which executed the within instrument; and that he/she signed his/her name thereto by order of the LLC.

Notary Public

STATE OF New York)
) ss.:
COUNTY OF Onondaga)

On this 23rd day of October, 2023, before me personally came John T. Camp, to me known, who being by me duly sworn, did depose and say that he/she resides in Onondaga County County, that he/she is the of Senior Vice President, the corporation described in, and which executed the within instrument; that he/she knows the seal of said corporation; that the seal affixed to said instrument is such corporate seal; that it was affixed by order to the Board of Directors of said corporation; and that he/she signed his/her name thereto by like order.

Michelle A. Steria
Notary Public

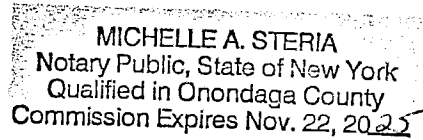

STATE OF NEW YORK)
) ss.:
COUNTY OF ALBANY)

On this _____ day of _____, 20____, before me personally came _____, to me known, who, being duly sworn, did depose and say that he resides in _____ County, that he is a _____ of _____ the partnership described in, and which executed the within instrument.

Notary Public

SCHEDULE "A"
SCOPE OF WORK



SCHEDULE A1

DESIGN SCOPE OF SERVICES

Project Title: Runway 01-19 Rehabilitation & Lighting Upgrades
Airport Name: Albany International Airport
Airport Sponsor: Albany County Airport Authority (ACAA)
Consultant: C&S Engineers, Inc.
Services Provided: Design

Project Description:

The CONSULTANT shall provide required services to design the Runway 01-19 Rehabilitation & Lighting Upgrades project (the "Project"). The Project will be performed and constructed by the SPONSOR with grant assistance from the Federal Aviation Administration (FAA) Airport Improvement Program (AIP) and the New York State Department of Transportation (NYSDOT).

This project generally includes the milling and overlaying of the 8,500 x 150-foot Runway 01-19 as well as the two associated blast pads at the Albany County Airport. Temporary pavement markings, permanent markings and saw-cut grooving will also be included. All runway threshold lights, edge lights, touchdown zone lights and centerline lights within the project limits will be retrofitted with new LED fixtures and appropriately sized transformers. Electrical cables, including homeruns to the vault will be replaced. Edge grading will be performed to remove built-up material located along the pavement edges.

In general, the pavement will be milled to a nominal depth and replaced at the same depth. The project design does not include topographic survey and will not include surface grade modifications and smoothness adjustments. Three-dimensional design modeling services are not being provided as directed by ACAA. Assumptions and exclusions used in preparation of this proposal are included at the end of this schedule

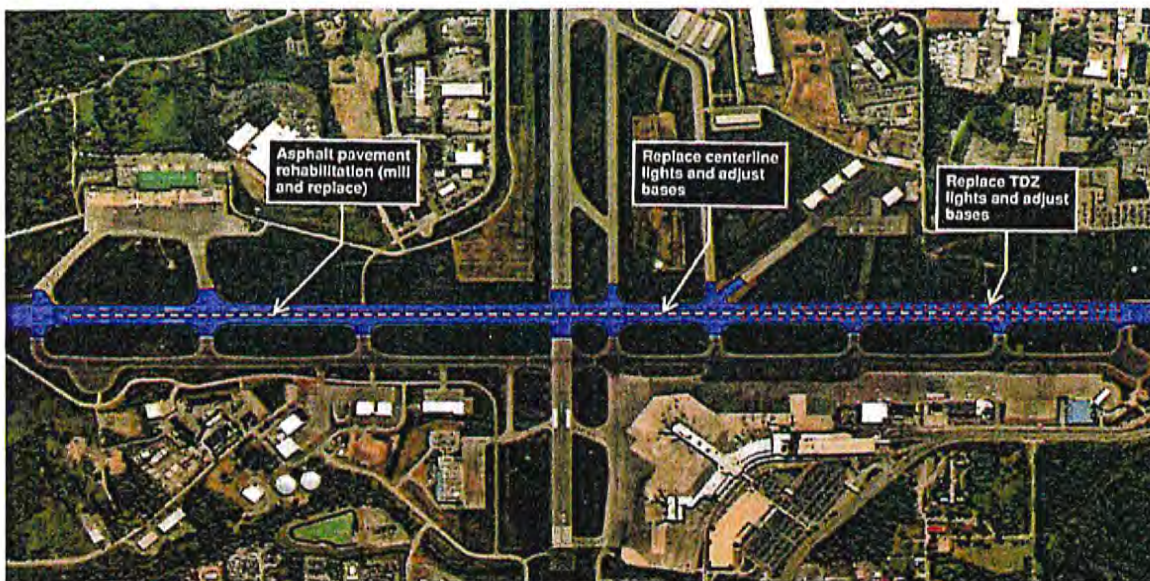



Services to be provided by the CONSULTANT shall include civil, electrical and geotechnical engineering services, as applicable, required to accomplish the following items ("Basic Services"):

PROJECT MANAGEMENT PHASE

The CONSULTANT shall aid the SPONSOR by acting as its liaison and Project coordinator with FAA and NYSDOT during the Project's design. The specific services to be provided or furnished for this Phase of the Project are the following:

1. Preparation or update of NEPA Categorical Exclusion (CATEX) Environmental Assessment.
2. Review the current Airport Layout Plan (ALP) to ensure the project is consistent with the document.
3. During the Design Phase, to aid the Sponsor by acting as its liaison and Project coordinator with the funding agencies.
4. The engineering and construction budget for the Project is \$10,000,000 (as reported in the ACAA RFQ). The Consultant shall evaluate the feasibility of this budget, based upon the Consultant's experience as a design professional, and keep the Sponsor apprised during each phase of the Project of the results of such evaluation. The Consultant shall advise the Sponsor as to options available for reducing construction costs to stay within the budget, if it appears likely that contractor bid prices will exceed this budget.
5. Perform project management duties such as project planning, invoice preparation, schedule coordination and coordination of design team.
6. Provide to the SPONSOR monthly project status reports.
7. Schedule coordination- consultant shall provide continued coordination so that project schedules are met for each phase of work included in this contract. Particular phases of design may be delayed by the FAA and NYSDOT's review processes.
8. The design schedule is anticipated to be as follows:

Task Name	Duration	Start	Finish
Runway 1-19 Rehabilitation Project	467 days	Fri 9/15/23	Tue 12/24/24
Scoping / Negotiations	10 days	Wed 9/20/23	Fri 9/29/23
C&S Engineers, Inc. Selected (October 16th Board Meeting)	0 days	Mon 10/16/23	Mon 10/16/23
ACAA Contract Approval	3 days	Mon 10/16/23	Wed 10/18/23
Design	105 days	Wed 10/18/23	Wed 1/31/24
Notice To Proceed	0 days	Wed 10/18/23	Wed 10/18/23
Field Work - Geotechnical	30 days	Thu 10/19/23	Fri 11/17/23
Schematic Design	14 days	Thu 10/19/23	Wed 11/1/23
Preliminary Design (60% Milestone Submittal)	14 days	Thu 11/2/23	Wed 11/15/23
Faa Review - (7460 and CSPP Uploads)	1 day	Thu 11/16/23	Thu 11/16/23
Draft Final Design	60 days	Thu 11/16/23	Sun 1/14/24
Bid Documents Design Submittal (100%)	15 days	Mon 1/15/24	Mon 1/29/24
Bidding (3 Weeks; Est. FAA Grant App Deadline 4-15-24)	30 days	Tue 1/30/24	Wed 2/28/24
FAA Funding (Dependent Upon Receipt of FAA Grant)	120 days	Thu 2/29/24	Thu 6/27/24
Construction Contract Execution	45 days	Fri 6/28/24	Sun 8/11/24
Estimated Construction Duration	60 days	Tue 8/27/24	Fri 10/25/24
Final Completion/ Construction Closeout	60 days	Sat 10/26/24	Tue 12/24/24



GRANT ADMINISTRATION PHASE

The CONSULTANT shall not include any Grants Administrative Services.

PRELIMINARY DESIGN PHASE (60% Design Submittal)

The Preliminary Design Phase is intended to identify and evaluate alternatives to provide cost-effective and practical solutions for the work items identified. The CONSULTANT will evaluate alternatives through contacts with local authorities, review of the pre-application, field investigations, and a practical design approach. The Project's design will take advantage of local knowledge and experience and will utilize expertise from recent construction projects in an effort to design a cost-effective Project. The specific services to be provided or furnished for this Phase of the Project are the following:

1. Schedule and conduct a pre-design meeting with the SPONSOR, FAA and NYSDOT to review the scope of services and become familiar with the Project requirements and operational concerns during the Project's construction.
2. Acquire and review record documents (such as plans, specifications, reports, and studies) to become familiar with data that is available for the Project.
3. Perform a preliminary Project site inspection to further familiarize the design team with Project areas. The pavement areas will be evaluated as far as additional distresses to be considered for repairs during construction.
4. Prepare preliminary plans identifying required pavement core locations, and other field investigative programs. Develop a schedule of completion of required investigations to minimize interference with airport and tenant operations. Coordinate schedule with SPONSOR and supervise programs at the Project site as necessary.
5. Acquire the necessary existing pavement investigation data, consisting of pavement cores only, to identify existing pavement conditions and characteristics. This project will have approximately 18 pavement cores. No soil borings, test pits or laboratory tests will be completed.
6. Perform a preliminary environmental review, including the collection and review of available documents such as published wetland maps, soil conservation survey maps, and previous master plan and environmental archaeological studies, to identify potential impacts the Project may have on the environment.
7. Complete appropriate NEPA forms (expected categorical exclusion, CATEX) and prepare and submit letters to governmental agencies requesting their review and determination regarding what, if any, impact the Project is expected to have on sensitive environmental areas. If anything required more than a CATEX, a supplemental agreement will be required and not included in this agreement.
8. Analyze data obtained from pavement cores and any existing pavement investigation programs and determine properties of existing pavement and soil materials. Document results of program, existing conditions, and recommendations in the design report.
9. Develop pavement design in accordance with FAA advisory circular 150/5320-6, latest edition. Pavement design to include one alternative for pavement rehabilitation (mill and replace at same depth). CONSULTANT will use FAA software FAARFIELD to perform design analysis. SPONSOR shall supply the CONSULTANT with the existing and future fleet mix.
10. Develop schematic designs, including preliminary pavement horizontal geometric layouts.



11. Develop preliminary airfield lighting layouts, electrical power distribution and system designs, and detail installations.
12. Develop an outline of general and technical specifications FAA AC 150/5370-10 or other sources as applicable.
13. Coordinate potential FAA reimbursable agreement for FAA-owned visual aid design, construction, and flight checks. Contact FAA NavAids Engineering Center and Planning and Requirements to determine if a reimbursable agreement is required as well as necessary FAA technical operations actions during construction. Include provisions in the Construction Safety and Phasing Plan (CSPP).
14. Prepare preliminary opinion of probable construction costs for each major element of the Project.
15. Identify potential Modifications to FAA Standards as potentially applicable for specifications or other FAA Advisory Circulars.
16. Develop a draft construction safety phasing plan (CSPP) that endeavors to limit interference by the Project's construction with airport and tenant operations. Stakeholder engagement and coordination.
17. Perform an internal quality control review on schematic design documents.
18. Submit 60% preliminary design to the sponsor, FAA and NYSDOT for their review.
19. Schedule and conduct a preliminary design review meeting with the SPONSOR to review the preliminary design and potential for Modifications to FAA Standards.

FINAL DESIGN PHASE

The services included under this Phase shall generally consist of services required to furnish the SPONSOR with a complete set of Contract Documents for the Project, including Final Plans, Specifications, Engineer's Design Report, and opinion of probable construction costs. Services to be performed or furnished during this Phase may include revising the preliminary submittal information to comply with SPONSOR, FAA AND NYSDOT comments and then completion of the final design. Plans and Specifications, suitable for unit price bidding, will be completed; final design will be coordinated with the SPONSOR, FAA and NYSDOT and a complete set of bid documents will be furnished to the SPONSOR, FAA and NYSDOT.

The specific services to be provided or furnished for this Phase of the Project are the following:

1. Finalize the design in order to finalize pavement geometry, typical sections, and other grading details for the proposed work.
2. Finalize pavement design
3. Detail and finalize pavement keyways, rehabilitation details and pavement sections.
4. Finalize airfield lighting layouts, electrical power distribution and system designs, and detail installations.
5. Finalize pavement marking layouts, and detail installations.



6. Prepare final Contract Drawings on 22" x 34" or 11" x 17" Paper. It is anticipated that the final drawings will consist of the following sheets:

Approx. Number of Sheets	Name
1	Title Sheet
1	Quantities for Canvass of Bids and Sheet Index
1	General Notes and Legend
1	General Plan
6	Construction Safety Phasing Plans
1	Construction Safety Phasing Details
12	Existing Conditions Plans
12	Demolition Plans
12	Geometry Plans
12	Grading Plans
4	Profiles
1	Typical Sections
1	Pavement Details
12	Lighting Plans
4	Lighting and Details
3	Electrical Vault Plans and Details
12	Marking Plans
1	Marking Details
6	Grooving Plans
1	Grooving Details

7. Perform a detailed quantity takeoff of all bid items to be included on the Contract Drawings and in the General Specifications of the Contract Documents.
8. Finalize written Technical Specifications for all construction materials and installations. FAA standard technical specifications shall be used whenever possible, with supplemental specifications developed by the consultant.
9. Finalize CSPP and include in Specifications and on the Contract Drawings.
10. Prepare final opinion of probable construction costs based upon the actual bid items and quantity takeoffs.
11. Finalize design report to be consistent with the final design.
12. Submit both the construction safety phasing plan and 7460 form electronically to the FAA.
13. Perform final internal quality control review on all design documents.
14. Submit draft final documents to the SPONSOR, FAA and NYSDOT for their final review and comment.
15. Schedule and conduct draft final review meeting with the SPONSOR, FAA and NYSDOT to discuss and resolve final comments.
16. Reproduce and submit sufficient copies of bid documents to SPONSOR for bidding purposes. Bid documents shall consist of the Contract Drawings and Specifications.



BID PHASE

The Bid Phase is that time frame between completion of the design process and beginning of actual construction when the SPONSOR publicly advertises and receives bids, awards contracts to the lowest responsible bidder, and executes a construction contract to perform the work with the successful contractor(s). The CONSULTANT shall assist the SPONSOR during this Phase as required.

The specific services to be provided or furnished for this Phase of the Project are the following:

1. Assist the SPONSOR in the advertisement of the Project and issuance of bid documents.
2. Receive and respond as required to questions from potential bidders regarding the Contract Documents.
3. Schedule and conduct pre-bid conference(s) by the SPONSOR and advise the SPONSOR on matters relating to design. Prepare meeting minutes of the pre-bid conference(s).
4. Prepare addenda to the bid documents after advertisement and prior to bidding as required upon the SPONSOR's approval.
5. Upon receipt of bids, perform bid reviews. The bid review shall include items such as a check of the contractor's bid extensions, bid security, execution of bid, non-collusive bidding certificate, EEO certification, statement of surety's intent, addenda receipt, "Buy American" certificate, subcontractors and suppliers list, Disadvantaged Business Enterprise (DBE) certification, eligibility certification, corporate bidder's certification, non-discrimination statement and nonsegregated facilities certificate. Request evidence of competency and evidence of financial responsibility from the contractor. Review contractor's list of personnel, list of equipment, and financial statement. Formal contact of the contractor's references shall be made upon SPONSOR's request or if the contractor has no past working relationship with the CONSULTANT, the SPONSOR, FAA or NYSDOT.
6. Prepare final bid tabulation, recommendation/rejection of award to the SPONSOR, and a sample award letter. Request concurrence of award from FAA.

DESIGN ASSUMPTIONS

The conditions and considerations in developing the scope and fee for the project described above include:

1. As-built drawings and/or CAD files are available and will be provided by ACAA.
2. Previous survey and as-built 3D elevations (provided by others) will be transmitted to CONSULTANT and are adequate for establishing existing surface lines and grades. Topographic survey if required can be provided for an additional fee.
3. The construction phasing shall be based on nightly closures from 10 PM to 6 AM (contractor to be off the runway at 5:30 AM).
4. Existing centerline and TDZ lights have top section extension rings. They must be removed to facilitate the paving operations. As-built documents will be used, and information will be field verified (spot checked, say 12 locations maximum) to make sure the extension rings are deep enough for milling and paving operations. Existing base cans and conduit will remain. ACAA electrician will assist with light fixture opening.
5. Access to the site for inspection/geotechnical investigation can only be performed during night hours and will be coordinated by the SPONSOR. SPONSOR will coordinate the necessary escort for the CONSULTANT and subcontractors to access the restricted areas located within "movement" areas of the airport. No-fee access to the site is provided.



6. The scope of services assumes that FAA will perform Safety Risk Management (SRM) review based on the draft CSPP, and that a Safety Risk Management Panel (SRMP) and safety risk mitigation will not be necessary. If SRMP is determined by FAA to be necessary, the cost of these services is not included in the CONSULTANT's original Scope of Services and shall therefore be an Additional Service.
7. The scope of services assumes that the topographic survey will not be required to follow FAA AC 150/5300-16, 17 and 18. If it is determined by FAA to be necessary, the cost of these services is not included in the CONSULTANT's original Scope of Services and shall therefore be an Additional Service.
8. Preparation of FAA applications and reimbursement requests will be performed by ACAA.
9. Cost evaluations will be based on bid prices from recent project at the airport and other similar regional airports.
10. Uploading the as-built data on the AGIS website will not be required.
11. Preparation of one (1) bid package for public bidding.
12. SPONSOR will advertise the Project and issuance of bid documents.
13. Advertisement, public bidding and award services will not be required of CONSULTANT.
14. Government agency fees for processing and permits are to be provided by SPONSOR.
15. SPONSOR to coordinate and submit permit application, if required. Note: Permits are not anticipated.
16. Airport staff will confirm that the proposed boring locations are not in conflict with underground utilities.
17. Prevailing wage rules apply to field work.
18. Pavement cores will be filled with non-shrink grout.
19. SPONSOR will provide the M&PT required for the geotechnical investigation (runway 1-19 closures).
20. SPONSOR will coordinate any required NAVAID shutdowns required for the geotechnical investigation.
21. A FAA airspace case, 7460 will not be required to perform pavement cores (truck only, no drill rig).

DESIGN EXCLUSIONS

The scope and fee for the project described above excludes the following items, which can be provided for an additional fee, if requested:

1. Front end contract documents. The front-end specifications will be prepared by ACAA.
2. Preparation of conformed copies of contracts; coordination of contractor's execution of contract; review of contractor's bonds, insurance certificates, and DBE plan; review of contractor's submission with SPONSOR.
3. Wetland delineation and mapping; archaeological and other environmental investigations as required by governmental agencies during the environmental review process.
4. Investigations and/or soil sampling for contaminants, hazardous material testing, and remediation design.



5. No airfield electrical vault work is included (constant current regulator replacement, etc.)
6. Underground utility locating (soft digs, potholing, etc.)
7. Underground utility inspections using a video camera.
8. Drainage studies, including hydrology or hydraulics.
9. Stormwater Pollution and Prevention Plan (SWPPP). Ground disturbance area is expected to be less than one acre and therefore a SWPPP will not be required by the New York State Department of Conservation (NYS DEC).
10. Government agency fees for processing and permits.
11. Uploading the As-built data on the AGIS website.
12. Updating FAA publications.
13. Construction support services including, materials testing, quality assurance services, and record drawings including mylar reproduction.
14. Any services not specifically identified in this scope of work are not anticipated and excluded.

END OF SCHEDULE A1



SCHEDULE A2

CONSTRUCTION ADMINISTRATION SCOPE OF SERVICES

Project Title: Runway 01-19 Rehabilitation & Lighting Upgrades
Airport Name: Albany International Airport
Airport Sponsor: Albany County Airport Authority (ACAA)
Consultant: C&S Engineers, Inc.
Services Provided: Construction Administration

PROJECT DESCRIPTION: Refer to schedule A1.

ANTICIPATED CONSTRUCTION SCHEDULE: Refer to schedule A1.

TASK 1- CONSTRUCTION ADMINISTRATION: Construction Contract Administration includes the following services:

- 1.1 Coordinate and assist SPONSOR with issuance of Notice to Proceed to contractor for construction.
- 1.2 Attend the pre-construction meeting (Chief Engineer attendance in person 2-hour meeting). It is assumed that the pre-construction meeting will be coordinated by others.
- 1.3 Provide consultation and advice to SPONSOR during construction including matters related to FAA compliance and regulations. The CONSULTANT will Support SPONSOR in conversations with the FAA.
- 1.4 Review, approve, or take other appropriate action on Contractor-required shop drawings, product data, catalog cuts, and samples. CONSULTANT will prepare a shop drawing/submittal log. Shop Drawings and responses to be uploaded to Doc Express or another Sponsor approved file sharing location.
- 1.5 Review alternative construction methods proposed by the Contractor and advise the SPONSOR of the impact of these methods and provide a recommendation on the schedule and quality of the Project.
- 1.6 Prepare supplemental drawings and change orders necessary to execute the work properly within the intended scope.
- 1.7 Provide interpretation of the Contract Document requirements and advise the Contractor of these on behalf of SPONSOR when necessary.
- 1.8 Review and respond to Contractor submitted Request for Information (RFIs) and upload responses to the construction team.
- 1.9 Virtual attendance at weekly progress meetings (12 assumed 1-hour meetings) as required.

EXCLUSIONS:

1. Construction observation and management. This will be a future separate agreement.

END OF SCHEDULE A2

SCHEDULE "B"

FEE SCHEDULE
(with Claim Form, attached)



**ARCHITECTURAL/ENGINEERING
COST SUMMARY
SCHEDULE "B"
DESIGN AND CONSTRUCTION**

PROJECT NAME: Runway 1-19 Rehabilitation and Lighting Upgrades
 PROJ DESCRIPTION Asphalt pavement mill and replace, Remove and replace lights
 CLIENT: Albany County Airport Authority (ACAA)
 CLIENT LEAD: John LaClair

DATE: 26-Sep-23
 A/E: C & S ENGINEERS, INC.
 PROJECT NO: Q23.PRO
 C&S CONTACT: Chris Brubach

I. ESTIMATE OF DIRECT SALARY COSTS:

TITLE	BILLING RATE (\$/HR)	@	ESTIMATED HOURS	ESTIMATED COST
A. President	\$419.00	X	0	\$0.00
B. Senior Vice President	\$446.00	X	0	\$0.00
C. Vice President	\$410.00	X	0	\$0.00
D. Service Group Manager	\$295.00	X	4	\$1,180.00
E. Department Manager	\$249.00	X	24	\$5,976.00
E. Senior Principal	\$263.00	X	0	\$0.00
F. Principal Engineer	\$241.00	X	176	\$42,416.00
G. Managing Engineer	\$216.00	X	0	\$0.00
H. Chief Engineer	\$214.00	X	310	\$66,340.00
I. Senior Project Engineer	\$197.00	X	40	\$7,880.00
J. Project Engineer	\$163.00	X	260	\$42,380.00
K. Engineer	\$137.00	X	500	\$68,500.00
L. Staff Engineer	\$121.00	X	0	\$0.00
M. Principal Architect	\$270.00	X	0	\$0.00
N. Managing Architect	\$210.00	X	0	\$0.00
O. Senior Project Architect	\$172.00	X	0	\$0.00
P. Project Architect	\$157.00	X	0	\$0.00
Q. Architect	\$145.00	X	0	\$0.00
R. Program Manager	\$213.00	X	0	\$0.00
S. Project Manager	\$175.00	X	0	\$0.00
T. Senior Project Manager	\$177.00	X	0	\$0.00
U. Senior Project Landscape Architect	\$165.00	X	0	\$0.00
V. Managing Environmental Scientist	\$215.00	X	0	\$0.00
W. Senior Project Environmental Scientist	\$166.00	X	40	\$6,640.00
X. Project Environmental Scientist	\$141.00	X	24	\$3,384.00
Y. Environmental Scientist	\$118.00	X	0	\$0.00
Z. Geologist	\$127.00	X	0	\$0.00
AA. Senior Project Designer	\$166.00	X	0	\$0.00
AB. Project Designer	\$139.00	X	0	\$0.00
AC. Senior Designer	\$133.00	X	160	\$21,280.00
AD. Designer	\$112.00	X	0	\$0.00
AE. Designer Technician	\$90.00	X	280	\$25,200.00
AF. Designer Technician (OT Rate)	\$135.00	X	0	\$0.00
AG. Senior Program Coordinator	\$153.00	X	0	\$0.00
AH. Program Coordinator	\$121.00	X	0	\$0.00
AI. Grants Writer	\$128.00	X	0	\$0.00
AJ. Grants Administrator	\$116.00	X	0	\$0.00
AK. Asslstant Grants Administrator	\$108.00	X	0	\$0.00



AL.	Managing Director	\$240.00	X	0	=	\$0.00
AM.	Director	\$236.00	X	0	=	\$0.00
AN.	Associate Director	\$217.00	X	0	=	\$0.00
AO.	Associate Director, Terminal	\$292.00	X	0	=	\$0.00
AP.	Principal Consultant	\$203.00	X	0	=	\$0.00
AQ.	Senior Consultant	\$175.00	X	0	=	\$0.00
AR.	Consultant	\$139.00	X	0	=	\$0.00
AS.	Construction Principal Engineer	\$268.00	X	0	=	\$0.00
AT.	Senior Construction Supervisor	\$229.00	X	0	=	\$0.00
AU.	Construction Supervisor	\$197.00	X	0	=	\$0.00
AV.	Resident Project Representative IV	\$188.00	X	0	=	\$0.00
AW.	Resident Project Representative III	\$172.00	X	0	=	\$0.00
AX.	Resident Project Representative III (OT Rate)	\$257.00	X	0	=	\$0.00
AY.	Resident Project Representative II	\$137.00	X	0	=	\$0.00
AZ.	Resident Project Representative II (OT Rate)	\$205.00	X	0	=	\$0.00
BA.	Resident Project Representative I	\$127.00	X	0	=	\$0.00
BB.	Resident Project Representative I (OT Rate)	\$191.00	X	0	=	\$0.00
BC.	Construction Manager 1	\$121.00	X	0	=	\$0.00
BD.	Construction Manager 2	\$143.00	X	0	=	\$0.00
BE.	Construction Manager 3	\$179.00	X	0	=	\$0.00
BF.	Resident Engineer	\$180.00	X	0	=	\$0.00
BG.	Senior Inspector	\$154.00	X	0	=	\$0.00
BH.	Office Engineer	\$156.00	X	0	=	\$0.00
BI.	Health & Safety Specialist	\$159.00	X	0	=	\$0.00
BJ.	Operations Manager	\$349.00	X	0	=	\$0.00
BK.	Program Director	\$328.00	X	0	=	\$0.00
BL.	Project Coordinator	\$130.00	X	0	=	\$0.00
BM.	Project Planner	\$130.00	X	0	=	\$0.00
BN.	Right of Way Specialist	\$185.00	X	0	=	\$0.00
BO.	Technical Administrator	\$127.00	X	0	=	\$0.00
BP.	Senior Technical Administrator	\$138.00	X	0	=	\$0.00
BQ.	Director of BIM Services	\$208.00	X	0	=	\$0.00
BR.	Civil CAD Manager	\$232.00	X	0	=	\$0.00
BS.	Aviation CAD Leader	\$139.00	X	0	=	\$0.00
BT.	GIS Analyst	\$127.00	X	0	=	\$0.00
BU.	Office Coordinator	\$96.00	X	40	=	\$3,840.00
BV.	Intern	\$83.00	X	0	=	\$0.00

TOTAL ESTIMATED DIRECT SALARY COST: \$295,016.00

II. ESTIMATE OF DIRECT EXPENSES:

A.	TRAVEL, BY AUTO:					
		6 TRIPS @ 300 MILES/TRIP @	\$0.655	=		\$1,179.00
B.	MISCELLANEOUS:			=		\$105.00

TOTAL ESTIMATE OF DIRECT EXPENSES: \$1,284.00

III. SUBCONTRACTS:

		DBE%	5.41%	
A.	ESTIMATE OF TOPOGRAPHICAL SURVEYS:			\$0.00
B.	CONSTRUCTION WORK PHASING CAD DRAFTING (AVIATION PLANNING GROUP)		DBE Firm	\$10,000.00



C. SUBSURFACE INVESTIGATION (RENAISSANCE GEOTECHNICAL ENGINEERING): DBE Firm

1	MOBILIZATION/DEMOB:	1	L.S. @	\$1,250.00	=	\$1,250.00
2	PAVEMENT CORES:	18	EACH @	\$275.00	=	\$4,950.00
3	REPORTING:	1	L.S. @	\$750.00	=	\$750.00

TOTAL ESTIMATED SUBSURFACE INVESTIGATION & TESTS: \$6,950.00

IV. TOTALS:

A. MAXIMUM TOTAL COST FOR SERVICES, AGREEMENT TOTAL: \$313,250.00

CLAIM FORM

TAX EXEMPT TAX ID NO. 14-1768979

SOLD TO: ALBANY COUNTY AIRPORT AUTHORITY		LEAVE THESE SPACES BLANK	
CLAIMANT		RECEIVED FOR AUDIT	AMOUNT
		ORDER	EXTENSIONS
ADDRESS		CLAIM APPROVED THIS DATE	AMOUNT
		SIGNED:	AUDITOR
OFFICE OR DEPARTMENT	CODE	DATE PAID:	CHECK NO.

P.O. NO.	QUANTITY	DESCRIPTION OF ITEMS OR WORK PERFORMED	UNIT PRICE	AMOUNT
		<small>LIST INVOICE OR SALES SLIP NUMBERS IF AVAILABLE</small>		
			TOTAL	\$

Claims must be rendered in DUPLICATE to head of department for which services or materials are furnished.

CERTIFICATE OF CLAIMANT

I, do hereby certify
 (Print or type name of person certifying, whether claimant, member of firm or officer of corporation)
 that I am

.....(if
 individual, leave blank, if partner, write "a member of the firm [naming the firm]"; if corporation, title of officer and name of corporation) and
 that this claim is true and correct and that the amount claimed is due, owing and unpaid; that the services were actually rendered, the
 disbursements actually and necessarily made or the supplies or equipment actually delivered and that the consideration has passed to the
 Albany County Airport Authority as stated herein; that no Federal or State taxes for which the Authority is exempt are included in the
 purchase price. Certified True and Correct.

NOTICE TO INDIVIDUAL CLAIMANTS	
If this claim is being submitted for payment to an individual for services rendered or for any reason other than reimbursement of expenses incurred on Authority business, you must supply your Fed. Tax ID No. or your Social Security No. in the space provided.	
Federal Tax Identification No. or Social Security No.	

.....
CLAIMANT

.....
BY

Dated.....20.....

CERTIFICATE OF APPROVAL BY DEPARTMENT HEAD OR OFFICER THROUGH WHOM CLAIM ORIGINATED

I hereby certify that the services enumerated in this claim were actually rendered by the persons named; the disbursements made; or the supplies or equipment were actually delivered, accepted, counted and inspected by me and are satisfactory and of the quantity and quality specified in such claim; that the contract price has been earned; that the services, disbursements, supplies or equipment were necessary and have been, or will be applied to the use of this department.

Dated....., 20.....

.....
HEAD OF DEPARTMENT

CLAIM NO. _____

SCHEDULE "C"
INSURANCE CERTIFICATE(S)



CERTIFICATE OF LIABILITY INSURANCE

DATE (MM/DD/YYYY)
10/23/2023

THIS CERTIFICATE IS ISSUED AS A MATTER OF INFORMATION ONLY AND CONFERS NO RIGHTS UPON THE CERTIFICATE HOLDER. THIS CERTIFICATE DOES NOT AFFIRMATIVELY OR NEGATIVELY AMEND, EXTEND OR ALTER THE COVERAGE AFFORDED BY THE POLICIES BELOW. THIS CERTIFICATE OF INSURANCE DOES NOT CONSTITUTE A CONTRACT BETWEEN THE ISSUING INSURER(S), AUTHORIZED REPRESENTATIVE OR PRODUCER, AND THE CERTIFICATE HOLDER.

IMPORTANT: If the certificate holder is an ADDITIONAL INSURED, the policy(ies) must have ADDITIONAL INSURED provisions or be endorsed. If SUBROGATION IS WAIVED, subject to the terms and conditions of the policy, certain policies may require an endorsement. A statement on this certificate does not confer rights to the certificate holder in lieu of such endorsement(s).

PRODUCER Haylor, Freyer & Coon, Inc. PO Box 4743 Syracuse NY 13221	CONTACT NAME: Ashley Franczak PHONE (A/C, No, Ext): 315-451-1500 E-MAIL ADDRESS: certificates@haylor.com	FAX (A/C, No):
	INSURER(S) AFFORDING COVERAGE	
INSURED C&S Engineers Inc. 499 Col Eileen Collins Blvd Syracuse, NY 13212 CSENGINEER	INSURER A: Travelers Indemnity Company	NAIC # 25658
	INSURER B: Charter Oak Fire Ins. Co.	25615
	INSURER C: Travelers Casualty Ins Co of America	19046
	INSURER D: Travelers Prop. Cas. Co. of America	25674
	INSURER E: Merchants Mutual	23329
	INSURER F: Travelers Excess & Surplus Lines Co	29696

COVERAGES **CERTIFICATE NUMBER:** 1443240752 **REVISION NUMBER:**

THIS IS TO CERTIFY THAT THE POLICIES OF INSURANCE LISTED BELOW HAVE BEEN ISSUED TO THE INSURED NAMED ABOVE FOR THE POLICY PERIOD INDICATED. NOTWITHSTANDING ANY REQUIREMENT, TERM OR CONDITION OF ANY CONTRACT OR OTHER DOCUMENT WITH RESPECT TO WHICH THIS CERTIFICATE MAY BE ISSUED OR MAY PERTAIN, THE INSURANCE AFFORDED BY THE POLICIES DESCRIBED HEREIN IS SUBJECT TO ALL THE TERMS, EXCLUSIONS AND CONDITIONS OF SUCH POLICIES. LIMITS SHOWN MAY HAVE BEEN REDUCED BY PAID CLAIMS.

INSR LTR	TYPE OF INSURANCE	ADDL SUBR		POLICY NUMBER	POLICY EFF (MM/DD/YYYY)	POLICY EXP (MM/DD/YYYY)	LIMITS	
		INSD	WVD					
A	<input checked="" type="checkbox"/> COMMERCIAL GENERAL LIABILITY <input type="checkbox"/> CLAIMS-MADE <input checked="" type="checkbox"/> OCCUR <input checked="" type="checkbox"/> Contractual <input type="checkbox"/> Liability GEN'L AGGREGATE LIMIT APPLIES PER: <input type="checkbox"/> POLICY <input checked="" type="checkbox"/> PRO-JECT <input checked="" type="checkbox"/> LOC OTHER:	Y	Y	6307E874377IND23	7/1/2023	7/1/2024	EACH OCCURRENCE	\$ 1,000,000
							DAMAGE TO RENTED PREMISES (Ea occurrence)	\$ 300,000
							MED EXP (Any one person)	\$ 10,000
							PERSONAL & ADV INJURY	\$ 1,000,000
							GENERAL AGGREGATE	\$ 2,000,000
							PRODUCTS - COMP/OP AGG	\$ 2,000,000
								\$
B	<input checked="" type="checkbox"/> AUTOMOBILE LIABILITY <input checked="" type="checkbox"/> ANY AUTO <input type="checkbox"/> OWNED AUTOS ONLY <input type="checkbox"/> HIRE AUTOS ONLY <input type="checkbox"/> SCHEDULED AUTOS <input type="checkbox"/> NON-OWNED AUTOS ONLY	Y	Y	8101N6679802236G	7/1/2023	7/1/2024	COMBINED SINGLE LIMIT (Ea accident)	\$ 1,000,000
							BODILY INJURY (Per person)	\$
							BODILY INJURY (Per accident)	\$
							PROPERTY DAMAGE (Per accident)	\$
								\$
D	<input type="checkbox"/> UMBRELLA LIAB <input checked="" type="checkbox"/> EXCESS LIAB <input type="checkbox"/> OCCUR <input type="checkbox"/> CLAIMS-MADE DED RETENTION \$	Y	Y	EX5T855169	7/1/2023	7/1/2024	EACH OCCURRENCE	\$ 5,000,000
							AGGREGATE	\$ 5,000,000
								\$
C	WORKERS COMPENSATION AND EMPLOYERS' LIABILITY ANY PROPRIETOR/PARTNER/EXECUTIVE OFFICER/MEMBER EXCLUDED? (Mandatory in NH) If yes, describe under DESCRIPTION OF OPERATIONS below Y/N <input checked="" type="checkbox"/> N N/A			UB7K6963972343G	7/1/2023	7/1/2024	<input checked="" type="checkbox"/> PER STATUTE <input type="checkbox"/> OTH-ER	
							E.L. EACH ACCIDENT	\$ 1,000,000
							E.L. DISEASE - EA EMPLOYEE	\$ 1,000,000
							E.L. DISEASE - POLICY LIMIT	\$ 1,000,000
E F	Umbrella Excess Liability			EXL0003145 ZUP16P3299923NF	7/1/2023 7/1/2023	7/1/2024 7/1/2024	\$5,000,000 P Occ/Agg Each Occurrence/Agg	\$10,000 Retention \$15,000,000

DESCRIPTION OF OPERATIONS / LOCATIONS / VEHICLES (ACORD 101, Additional Remarks Schedule, may be attached if more space is required)
 See Attached Acord 101
 Where required by written contract Albany County Airport Authority and its agent, AFCA AvPorts Management, LLC, County of Albany, Federal Aviation Administration, and the State of New York are additional insureds where applicable, per policy terms and conditions.
 This project is: Contract S-1162; Albany International Airport Runway 01-19 Rehab & Lighting Upgrades

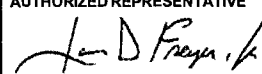
CERTIFICATE HOLDER Albany County Airport Authority Administration Building, Rm. 200 Albany International Airport Albany NY 12211	CANCELLATION SHOULD ANY OF THE ABOVE DESCRIBED POLICIES BE CANCELLED BEFORE THE EXPIRATION DATE THEREOF, NOTICE WILL BE DELIVERED IN ACCORDANCE WITH THE POLICY PROVISIONS.
	AUTHORIZED REPRESENTATIVE 



ADDITIONAL REMARKS SCHEDULE

AGENCY Haylor, Freyer & Coon, Inc.		NAMED INSURED C&S Engineers, Inc. 499 Col Eileen Collins Blvd. Syracuse, NY 13212	
POLICY NUMBER		EFFECTIVE DATE:	
CARRIER	NAIC CODE		

ADDITIONAL REMARKS

**THIS ADDITIONAL REMARKS FORM IS A SCHEDULE TO ACORD FORM,
FORM NUMBER: 25 FORM TITLE: CERTIFICATE OF LIABILITY INSURANCE**

Forms Enclosed:

General Liability:

- CG T8 03 - Blanket Additional Insured (Contractors)- New York
- CG D3 79 (02/19) - Xtend Endorsement for Architects, Engineers, and Surveyors- Waiver
- IL T4 05 (05/19) - Designated Entity- Notice of Cancellation Provided By Us

Automobile:

- CA T4 74 (02/16) - Blanket Additional Insured- Primary and Non-Contributory with Other Insurance
- CA T9 60 (02/15) - New York Business Auto Coverage Extension Form

Workers Compensation: WC 00 03 13 (00) - Waiver of Our Right to Recover from Others Endorsement

COMMERCIAL GENERAL LIABILITY

sured when that person or organization is an additional insured under such other insurance.

5. As a condition of coverage, each additional insured must:

- a.) Give us written notice of any "occurrence" or offense which may result in a claim and written notice of "suit" as soon as reasonably possible.
- b.) Immediately forward all legal papers to us, cooperate in the investigation or settlement of the claim or defense against the "suit," and otherwise comply with policy conditions.
- c.) Tender the defense and indemnity of any claim or "suit" to any other insurer which also insures against a loss we cover under this endorsement. This includes, but is not limited to, any insurer which has issued a policy of insurance in which the additional insured

qualifies as an insured. For purposes of this requirement, the term "insures against" refers to any self-insurance and to any insurer which issued a policy of insurance that may provide coverage for the loss, regardless of whether the additional insured has actually requested that the insurer provide the additional insured with a defense and/or indemnity under that policy of insurance.

- d.) Agree to make available any other insurance that the additional insured has for a loss we cover under this endorsement.

However, paragraphs 5.c.) and d.) above do not affect whether the insurance provided to the additional insured by this endorsement is primary to other insurance available to the additional insured which covers that person or organization as a named insured as described in paragraph 4. above.

COMMERCIAL GENERAL LIABILITY

- b. Such subsidiary is not an insured under similar other insurance.

No such subsidiary is an insured for "bodily injury" or "property damage" that occurred, or "personal and advertising injury" caused by an offense committed:

- a. Before you maintained an ownership interest of more than 50% in such subsidiary; or
- b. After the date, if any, during the policy period that you no longer maintain an ownership interest of more than 50% in such subsidiary.

For purposes of Paragraph 1. of Section II – Who Is An Insured, each such subsidiary will be deemed to be designated in the Declarations as:

- a. A limited liability company;
- b. An organization other than a partnership, joint venture or limited liability company; or
- c. A trust;

as indicated in its name or the documents that govern its structure.

C. WHO IS AN INSURED – RETIRED PARTNERS, MEMBERS, DIRECTORS AND EMPLOYEES

The following is added to Paragraph 2. of SECTION II – WHO IS AN INSURED:

Any person who is your retired partner, member, director or "employee" that is performing services for you under your direct supervision, but only for acts within the scope of their employment by you or while performing duties related to the conduct of your business. However, no such retired partner, member, director or "employee" is an insured for:

(1) "Bodily injury":

- (a) To you, to your current partners or members (if you are a partnership or joint venture), to your current members (if you are a limited liability company) or to your current directors;
- (b) To the spouse, child, parent, brother or sister of that current partner, member or director as a consequence of Paragraph (1)(a) above;
- (c) For which there is any obligation to share damages with or repay someone else who must pay damages because of the injury described in Paragraph (1)(a) or (b) above; or
- (d) Arising out of his or her providing or failing to provide professional health care services.

Unless you are in the business or occupation of providing professional health care services, Paragraphs (1)(a), (b), (c) and (d) above do not apply to "bodily injury" arising out of providing or failing to provide first aid or "Good Samaritan services" by any of your retired partners, members, directors or "employees", other than a doctor. Any such retired partners, members, directors or "employees" providing or failing to provide first aid or "Good Samaritan services" during their work hours for you will be deemed to be acting within the scope of their employment by you or performing duties related to the conduct of your business.

(2) "Personal injury":

- (a) To you, to your current or retired partners or members (if you are a partnership or joint venture), to your current or retired members (if you are a limited liability company), to your other current or retired directors or "employees" while in the course of his or her employment or performing duties related to the conduct of your business, or to your other "volunteer workers" while performing duties related to the conduct of your business;
- (b) To the spouse, child, parent, brother or sister of that current or retired partner, member, director, "employee" or "volunteer worker" as a consequence of Paragraph (2)(a) above;
- (c) For which there is any obligation to share damages with or repay someone else who must pay damages because of the injury described in Paragraph (2)(a) or (b) above; or
- (d) Arising out of his or her providing or failing to provide professional health care services.

(3) "Property damage" to property:

- (a) Owned, occupied or used by; or
- (b) Rented to, in the care, custody or control of, or over which physical control is being exercised for any purpose by;

you, any of your retired partners, members or directors, your current or retired "employees" or "volunteer workers", any current partner or member (if you are a partnership or joint venture), or any current member (if you are a limited liability company) or current director.

COMMERCIAL GENERAL LIABILITY

subsequent to the signing of that contract or agreement; and

- b. Arises out of the ownership, maintenance or use of the premises for which that mortgagee, assignee, successor or receiver is required under that contract or agreement to be included as an additional insured on this Coverage Part.

The insurance provided to such mortgagee, assignee, successor or receiver is subject to the following provisions:

- a. The limits of insurance provided to such mortgagee, assignee, successor or receiver will be the minimum limits that you agreed to provide in the written contract or agreement, or the limits shown in the Declarations, whichever are less.
- b. The insurance provided to such person or organization does not apply to:
 - (1) Any "bodily injury" or "property damage" that occurs, or any "personal and advertising injury" caused by an offense that is committed, after such contract or agreement is no longer in effect; or
 - (2) Any "bodily injury", "property damage" or "personal and advertising injury" arising out of any structural alterations, new construction or demolition operations performed by or on behalf of such mortgagee, assignee, successor or receiver.

H. BLANKET ADDITIONAL INSURED – GOVERNMENTAL ENTITIES – PERMITS OR AUTHORIZATIONS RELATING TO PREMISES

The following is added to **SECTION II – WHO IS AN INSURED**:

Any governmental entity that has issued a permit or authorization with respect to premises owned or occupied by, or rented or loaned to, you and that you are required by any ordinance, law, building code or written contract or agreement to include as an additional insured on this Coverage Part is an insured, but only with respect to liability for "bodily injury", "property damage" or "personal and advertising injury" arising out of the existence, ownership, use, maintenance, repair, construction, erection or removal of any of the following for which that governmental entity has issued such permit or authorization: advertising signs, awnings, canopies, cellar entrances, coal holes, driveways, manholes, marquees, hoist away

openings, sidewalk vaults, elevators, street banners or decorations.

I. BLANKET ADDITIONAL INSURED – GOVERNMENTAL ENTITIES – PERMITS OR AUTHORIZATIONS RELATING TO OPERATIONS

The following is added to **SECTION II – WHO IS AN INSURED**:

Any governmental entity that has issued a permit or authorization with respect to operations performed by you or on your behalf and that you are required by any ordinance, law, building code or written contract or agreement to include as an additional insured on this Coverage Part is an insured, but only with respect to liability for "bodily injury", "property damage" or "personal and advertising injury" arising out of such operations.

The insurance provided to such governmental entity does not apply to:

- a. Any "bodily injury", "property damage" or "personal and advertising injury" arising out of operations performed for the governmental entity; or
- b. Any "bodily injury" or "property damage" included in the "products-completed operations hazard".

J. INCIDENTAL MEDICAL MALPRACTICE

1. The following replaces Paragraph **b.** of the definition of "occurrence" in the **DEFINITIONS** Section:

- b. An act or omission committed in providing or failing to provide "incidental medical services", first aid or "Good Samaritan services" to a person, unless you are in the business or occupation of providing professional health care services.

2. The following replaces the last paragraph of Paragraph **2.a.(1)** of **SECTION II – WHO IS AN INSURED**:

Unless you are in the business or occupation of providing professional health care services, Paragraphs **(1)(a), (b), (c)** and **(d)** above do not apply to "bodily injury" arising out of providing or failing to provide:

- (a) "Incidental medical services" by any of your "employees" who is a nurse, nurse assistant, emergency medical technician, paramedic, athletic trainer, audiologist, dietician, nutritionist,

COMMERCIAL GENERAL LIABILITY

N. CONTRACTUAL LIABILITY – RAILROADS

1. The following replaces Paragraph **c.** of the definition of "insured contract" in the **DEFINITIONS** Section:
 - c.** Any easement or license agreement;
2. Paragraph **f.(1)** of the definition of "insured contract" in the **DEFINITIONS** Section is deleted.

- (1) Any covered "auto" you lease, hire, rent or borrow; and
- (2) Any covered "auto" hired or rented by your "employee" under a contract in an "employee's" name, with your permission, while performing duties related to the conduct of your business.

However, any "auto" that is leased, hired, rented or borrowed with a driver is not a covered "auto".

D. EMPLOYEES AS INSURED

The following is added to Paragraph A.1., **Who Is An Insured**, of SECTION II – COVERED AUTOS LIABILITY COVERAGE:

Any "employee" of yours is an "insured" while using a covered "auto" you don't own, hire or borrow in your business or your personal affairs.

E. SUPPLEMENTARY PAYMENTS – INCREASED LIMITS

1. The following replaces Paragraph A.2.a.(2), of SECTION II – COVERED AUTOS LIABILITY COVERAGE:
 - (2) Up to \$3,000 for cost of bail bonds (including bonds for related traffic law violations) required because of an "accident" we cover. We do not have to furnish these bonds.
2. The following replaces Paragraph A.2.a.(4), of SECTION II – COVERED AUTOS LIABILITY COVERAGE:
 - (4) All reasonable expenses incurred by the "insured" at our request, including actual loss of earnings up to \$500 a day because of time off from work.

F. WAIVER OF DEDUCTIBLE – GLASS

The following is added to Paragraph D., **Deductible**, of SECTION III – PHYSICAL DAMAGE COVERAGE:

No deductible for a covered "auto" will apply to glass damage if the glass is repaired rather than replaced.

G. HIRED AUTO PHYSICAL DAMAGE – LOSS OF USE – INCREASED LIMIT

The following replaces the last sentence of Paragraph A.4.b., **Loss Of Use Expenses**, of SECTION III – PHYSICAL DAMAGE COVERAGE:

However, the most we will pay for any expenses for loss of use is \$65 per day, to a maximum of \$750 for any one "accident".

H. PHYSICAL DAMAGE – TRANSPORTATION EXPENSES – INCREASED LIMIT

The following replaces the first sentence in Paragraph A.4.a., **Transportation Expenses**, of SECTION III – PHYSICAL DAMAGE COVERAGE:

We will pay up to \$50 per day to a maximum of \$1,500 for temporary transportation expense incurred by you because of the total theft of a covered "auto" of the private passenger type.

I. PERSONAL PROPERTY

The following is added to Paragraph A.4., **Coverage Extensions**, of SECTION III – PHYSICAL DAMAGE COVERAGE:

Personal Property

We will pay up to \$400 for "loss" to wearing apparel and other personal property which is:

- (1) Owned by an "insured"; and
- (2) In or on your covered "auto".

This coverage applies only in the event of a total theft of your covered "auto".

No deductibles apply to this Personal Property coverage.

J. AIRBAGS

The following is added to Paragraph B.3., **Exclusions**, of SECTION III – PHYSICAL DAMAGE COVERAGE:

Exclusion 3.a. does not apply to "loss" to one or more airbags in a covered "auto" you own that inflate due to a cause other than a cause of "loss" set forth in Paragraphs A.1.b. and A.1.c., but only:

- a. If that "auto" is a covered "auto" for Comprehensive Coverage under this policy;
- b. The airbags are not covered under any warranty; and
- c. The airbags were not intentionally inflated.

We will pay up to a maximum of \$1,000 for any one "loss".

K. NOTICE AND KNOWLEDGE OF ACCIDENT OR LOSS

The following is added to Paragraph A.2.a., of SECTION IV – BUSINESS AUTO CONDITIONS:

Your duty to give us or our authorized representative notice as soon as reasonably

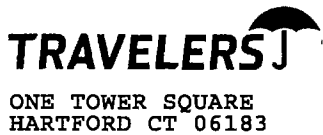

**WORKERS COMPENSATION
AND
EMPLOYERS LIABILITY POLICY
ENDORSEMENT WC 00 03 13 (00)**

POLICY NUMBER: UB7K6963972343G

WAIVER OF OUR RIGHT TO RECOVER FROM OTHERS ENDORSEMENT

We have the right to recover our payments from anyone liable for an injury covered by this policy. We will not enforce our right against the person or organization named in the Schedule. (This agreement applies only to the extent that you perform work under a written contract that requires you to obtain this agreement from us.)

This agreement shall not operate directly or indirectly to benefit any one not named in the Schedule.

SCHEDULE

DESIGNATED PERSON:

DESIGNATED ORGANIZATION:

ANY PERSON OR ORGANIZATION FOR WHICH THE INSURED HAS AGREED
BY WRITTEN CONTRACT EXECUTED PRIOR TO LOSS TO FURNISH THIS
WAIVER.



CERTIFICATE OF LIABILITY INSURANCE

DATE (MM/DD/YYYY)

10/24/2023

THIS CERTIFICATE IS ISSUED AS A MATTER OF INFORMATION ONLY AND CONFERS NO RIGHTS UPON THE CERTIFICATE HOLDER. THIS CERTIFICATE DOES NOT AFFIRMATIVELY OR NEGATIVELY AMEND, EXTEND OR ALTER THE COVERAGE AFFORDED BY THE POLICIES BELOW. THIS CERTIFICATE OF INSURANCE DOES NOT CONSTITUTE A CONTRACT BETWEEN THE ISSUING INSURER(S), AUTHORIZED REPRESENTATIVE OR PRODUCER, AND THE CERTIFICATE HOLDER.

IMPORTANT: If the certificate holder is an **ADDITIONAL INSURED**, the policy(ies) must have **ADDITIONAL INSURED** provisions or be endorsed. If **SUBROGATION IS WAIVED**, subject to the terms and conditions of the policy, certain policies may require an endorsement. A statement on this certificate does not confer rights to the certificate holder in lieu of such endorsement(s).

PRODUCER Greyling Ins Brokerage/EPIC 3780 Mansell Road, Suite 370 Alpharetta GA 30022	CONTACT NAME: Sharon Brubaker
	PHONE (A/C, No., Ext): 770.756.6599 FAX (A/C, No):
E-MAIL ADDRESS: greylingcerts@greyling.com	
INSURER(S) AFFORDING COVERAGE	
INSURER A: Berkley Assurance Company NAIC # 39462	
INSURER B:	
INSURER C:	
INSURER D:	
INSURER E:	
INSURER F:	

INSURED C&S Engineers, Inc. **C&SWORL**
 499 Col. Eileen Collins Blvd
 Syracuse, NY 13212-0000

COVERAGES **CERTIFICATE NUMBER:** 1466987216 **REVISION NUMBER:**

THIS IS TO CERTIFY THAT THE POLICIES OF INSURANCE LISTED BELOW HAVE BEEN ISSUED TO THE INSURED NAMED ABOVE FOR THE POLICY PERIOD INDICATED. NOTWITHSTANDING ANY REQUIREMENT, TERM OR CONDITION OF ANY CONTRACT OR OTHER DOCUMENT WITH RESPECT TO WHICH THIS CERTIFICATE MAY BE ISSUED OR MAY PERTAIN, THE INSURANCE AFFORDED BY THE POLICIES DESCRIBED HEREIN IS SUBJECT TO ALL THE TERMS, EXCLUSIONS AND CONDITIONS OF SUCH POLICIES. LIMITS SHOWN MAY HAVE BEEN REDUCED BY PAID CLAIMS.

INSR LTR	TYPE OF INSURANCE	ADDL INSD	SUBR WVP	POLICY NUMBER	POLICY EFF (MM/DD/YYYY)	POLICY EXP (MM/DD/YYYY)	LIMITS
	COMMERCIAL GENERAL LIABILITY <input type="checkbox"/> CLAIMS-MADE <input type="checkbox"/> OCCUR GEN'L AGGREGATE LIMIT APPLIES PER: <input type="checkbox"/> POLICY <input type="checkbox"/> PRO-JECT <input type="checkbox"/> LOC OTHER:						EACH OCCURRENCE \$ DAMAGE TO RENTED PREMISES (Ea occurrence) \$ MED EXP (Any one person) \$ PERSONAL & ADV INJURY \$ GENERAL AGGREGATE \$ PRODUCTS - COMP/OP AGG \$ \$
	AUTOMOBILE LIABILITY <input type="checkbox"/> ANY AUTO <input type="checkbox"/> OWNED AUTOS ONLY <input type="checkbox"/> SCHEDULED AUTOS <input type="checkbox"/> HIRED AUTOS ONLY <input type="checkbox"/> NON-OWNED AUTOS ONLY <input type="checkbox"/> AUTOS ONLY						COMBINED SINGLE LIMIT (Ea accident) \$ BODILY INJURY (Per person) \$ BODILY INJURY (Per accident) \$ PROPERTY DAMAGE (Per accident) \$ \$
	UMBRELLA LIAB <input type="checkbox"/> OCCUR EXCESS LIAB <input type="checkbox"/> CLAIMS-MADE DED RETENTION \$						EACH OCCURRENCE \$ AGGREGATE \$ \$
	WORKERS COMPENSATION AND EMPLOYERS' LIABILITY ANY PROPRIETOR/PARTNER/EXECUTIVE OFFICER/MEMBER EXCLUDED? (Mandatory in NH) If yes, describe under DESCRIPTION OF OPERATIONS below	Y/N	N/A				<input type="checkbox"/> PER STATUTE <input type="checkbox"/> OTH-ER E.L. EACH ACCIDENT \$ E.L. DISEASE - EA EMPLOYEE \$ E.L. DISEASE - POLICY LIMIT \$
A	Professional Liab Incl. Pollution Liability			PCAB50224950723	7/1/2023	7/1/2024	Per Claim Aggregate \$5,000,000 \$5,000,000

DESCRIPTION OF OPERATIONS / LOCATIONS / VEHICLES (ACORD 101, Additional Remarks Schedule, may be attached if more space is required)
 Re: Contract S-1162; Albany International Airport Runway 01-19 Rehab & Lighting Upgrades.
 Should any of the above described policies be cancelled by the issuing insurer before the expiration date thereof, we will endeavor to provide 30 days' written notice (except 10 days for nonpayment of premium) to the Certificate Holder.

CERTIFICATE HOLDER **CANCELLATION**

Albany County Airport Authority Albany International Airport 737 Albany Shaker Rd Albany, NY 12211	SHOULD ANY OF THE ABOVE DESCRIBED POLICIES BE CANCELLED BEFORE THE EXPIRATION DATE THEREOF, NOTICE WILL BE DELIVERED IN ACCORDANCE WITH THE POLICY PROVISIONS. AUTHORIZED REPRESENTATIVE
---	---

© 1988-2015 ACORD CORPORATION. All rights reserved.



**CERTIFICATE OF INSURANCE COVERAGE
NYS DISABILITY AND PAID FAMILY LEAVE BENEFITS LAW**

PART 1. To be completed by NYS disability and Paid Family Leave benefits carrier or licensed insurance agent of that carrier

<p>1a. Legal Name & Address of Insured (use street address only) C & S ENGINEERS INC. 499 COL EILEEN COLLINS BLVD SYRACUSE, NY 13212</p> <p>Work Location of Insured (Only required if coverage is specifically limited to certain locations in New York State, i.e., Wrap-Up Policy)</p>	<p>1b. Business Telephone Number of Insured (315)-703-4170</p> <p>1c. Federal Employer Identification Number of Insured or Social Security Number 13 5318940</p>
<p>2. Name and Address of Entity Requesting Proof of Coverage (Entity Being Listed as the Certificate Holder) ALBANY COUNTY AIRPORT AUTHORITY ALBANY INTERNATIONAL AIRPORT ADMIN BLDG., RM. 200 ALBANY NY 12211</p>	<p>3a. Name of Insurance Carrier The Guardian Life Insurance Company of America</p> <p>3b. Policy Number of Entity Listed in Box 1a 00974254 0001</p> <p>3c. Policy Effective Period 04/01/2023 to 04/01/2024</p>

4. Policy provides the following benefits:

- A. Both disability and Paid Family Leave benefits.
- B. Disability benefits only.
- C. Paid Family Leave benefits only.

5. Policy covers:

- A. All of the employer's employees eligible under the NYS Disability and Paid Family Leave Benefits Law.
- B. Only the following class or classes of employer's employees:

Under penalty of perjury, I certify that I am an authorized representative or licensed agent of the insurance carrier referenced above and that the named insured has NYS disability and/or Paid Family Leave benefits insurance coverage as described above.

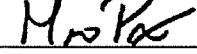
Date Signed 04/03/2023 By 
(Signature of insurance carrier's authorized representative or NYS licensed insurance agent of that insurance carrier)

Telephone Number 1-888-278-4542 Name and Title Michael Prestileo, Head of Group Benefits Strategy, Product & Underwriting

IMPORTANT: If Boxes 4A and 5A are checked, and this form is signed by the insurance carrier's authorized representative or NYS Licensed Insurance Agent of that carrier, this certificate is COMPLETE. Mail it directly to the certificate holder.

If Box 4B, 4C or 5B is checked, this certificate is NOT COMPLETE for purposes of Section 220, Subd. 8 of the NYS Disability and Paid Family Leave Benefits Law. It must be emailed to PAU@wcb.ny.gov or it can be mailed for completion to the Workers' Compensation Board, Plans Acceptance Unit, PO Box 5200, Binghamton, NY 13902-5200.

PART 2. To be completed by the NYS Workers' Compensation Board (Only if Box 4B, 4C or 5B have been checked)

**State of New York
Workers' Compensation Board**

According to information maintained by the NYS Workers' Compensation Board, the above-named employer has complied with the NYS Disability and Paid Family Leave Benefits Law (Article 9 of the Workers' Compensation Law) with respect to all of their employees.

Date Signed _____ By _____
(Signature of Authorized NYS Workers' Compensation Board Employee)

Telephone Number _____ Name and Title _____

Please Note: Only insurance carriers licensed to write NYS disability and Paid Family Leave benefits insurance policies and NYS licensed insurance agents of those insurance carriers are authorized to issue Form DB-120.1. Insurance brokers are NOT authorized to issue this form.

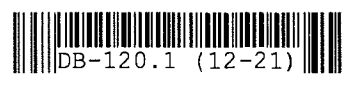



**CERTIFICATE OF
NYS WORKERS' COMPENSATION INSURANCE COVERAGE**

<p>1a. Legal Name & Address of Insured (use street address only) C&S Engineers, Inc., C&S Architects Engineers & Landscape Architect, PLLC 499 Col Eileen Collins Blvd. Syracuse NY 13212</p> <p>Work Location of Insured (Only required if coverage is specifically limited to certain locations in New York State, i.e., a Wrap-Up Policy)</p>	<p>1b. Business Telephone Number of Insured 315-455-2000</p> <p>1c. NYS Unemployment Insurance Employer Registration Number of Insured</p> <p>1d. Federal Employer Identification Number of Insured or Social Security Number 13-5318940</p>
<p>2. Name and Address of Entity Requesting Proof of Coverage (Entity Being Listed as the Certificate Holder) Albany County Airport Authority Albany International Airport Admin Bldg., Room 200 Albany NY 12211</p>	<p>3a. Name of Insurance Carrier Travelers Casualty Ins Co of America</p> <p>3b. Policy Number of Entity Listed in Box "1a" UB7K6963972343G</p> <p>3c. Policy effective period 7/1/2023 to 7/1/2024</p> <p>3d. The Proprietor, Partners or Executive Officers are <input checked="" type="checkbox"/> included. (Only check box if all partners/officers included) <input type="checkbox"/> all excluded or certain partners/officers excluded.</p>

This certifies that the insurance carrier indicated above in box "3" insures the business referenced above in box "1a" for workers' compensation under the New York State Workers' Compensation Law. (To use this form, New York (NY) must be listed under Item 3A on the INFORMATION PAGE of the workers' compensation insurance policy). **The Insurance Carrier or its licensed agent will send this Certificate of Insurance to the entity listed above as the certificate holder in box "2".**

Will the carrier notify the certificate holder within 10 days of a policy being cancelled for non-payment of premium or within 30 days if cancelled for any other reason or if the insured is otherwise eliminated from the coverage indicated on this certificate prior to the end of the policy effective period? YES NO

This certificate is issued as a matter of information only and confers no rights upon the certificate holder. This certificate does not amend, extend or alter the coverage afforded by the policy listed, nor does it confer any rights or responsibilities beyond those contained in the referenced policy.

This certificate may be used as evidence of a Workers' Compensation contract of insurance only while the underlying policy is in effect.

Please Note: Upon cancellation of the workers' compensation policy indicated on this form, if the business continues to be named on a permit, license or contract issued by a certificate holder, the business must provide that certificate holder with a new Certificate of Workers' Compensation Coverage or other authorized proof that the business is complying with the mandatory coverage requirements of the New York State Workers' Compensation Law.

Under penalty of perjury, I certify that I am an authorized representative or licensed agent of the insurance carrier referenced above and that the named insured has the coverage as depicted on this form.

Approved by: James D. Freyer, Jr
(Print name of authorized representative or licensed agent of insurance carrier)

Approved by:  6/27/2023
(Signature) (Date)

Title: CEO

Telephone Number of authorized representative or licensed agent of insurance carrier: 315-451-1500

Please Note: Only insurance carriers and their licensed agents are authorized to issue Form C-105.2. Insurance brokers are NOT authorized to issue it.

APPENDIX A

STANDARD CLAUSES FOR NEW YORK STATE CONTRACTS

**PLEASE RETAIN THIS DOCUMENT
FOR FUTURE REFERENCE.**

January 2014

TABLE OF CONTENTS

	Page
1. Executory Clause	3
2. Non-Assignment Clause	3
3. Comptroller's Approval	3
4. Workers' Compensation Benefits	3
5. Non-Discrimination Requirements	3
6. Wage and Hours Provisions	3
7. Non-Collusive Bidding Certification	4
8. International Boycott Prohibition	4
9. Set-Off Rights	4
10. Records	4
11. Identifying Information and Privacy Notification	4
12. Equal Employment Opportunities For Minorities and Women	4-5
13. Conflicting Terms	5
14. Governing Law	5
15. Late Payment	5
16. No Arbitration	5
17. Service of Process	5
18. Prohibition on Purchase of Tropical Hardwoods	5-6
19. MacBride Fair Employment Principles	6
20. Omnibus Procurement Act of 1992	6
21. Reciprocity and Sanctions Provisions	6
22. Compliance with New York State Information Security Breach and Notification Act	6
23. Compliance with Consultant Disclosure Law	6
24. Procurement Lobbying	7
25. Certification of Registration to Collect Sales and Compensating Use Tax by Certain State Contractors, Affiliates and Subcontractors	7
26. Iran Divestment Act	7

STANDARD CLAUSES FOR NYS CONTRACTS

The parties to the attached contract, license, lease, amendment or other agreement of any kind (hereinafter, "the contract" or "this contract") agree to be bound by the following clauses which are hereby made a part of the contract (the word "Contractor" herein refers to any party other than the State, whether a contractor, licenser, licensee, lessor, lessee or any other party):

1. EXECUTORY CLAUSE. In accordance with Section 41 of the State Finance Law, the State shall have no liability under this contract to the Contractor or to anyone else beyond funds appropriated and available for this contract.

2. NON-ASSIGNMENT CLAUSE. In accordance with Section 138 of the State Finance Law, this contract may not be assigned by the Contractor or its right, title or interest therein assigned, transferred, conveyed, sublet or otherwise disposed of without the State's previous written consent, and attempts to do so are null and void. Notwithstanding the foregoing, such prior written consent of an assignment of a contract let pursuant to Article XI of the State Finance Law may be waived at the discretion of the contracting agency and with the concurrence of the State Comptroller where the original contract was subject to the State Comptroller's approval, where the assignment is due to a reorganization, merger or consolidation of the Contractor's business entity or enterprise. The State retains its right to approve an assignment and to require that any Contractor demonstrate its responsibility to do business with the State. The Contractor may, however, assign its right to receive payments without the State's prior written consent unless this contract concerns Certificates of Participation pursuant to Article 5-A of the State Finance Law.

3. COMPTROLLER'S APPROVAL. In accordance with Section 112 of the State Finance Law (or, if this contract is with the State University or City University of New York, Section 355 or Section 6218 of the Education Law), if this contract exceeds \$50,000 (or the minimum thresholds agreed to by the Office of the State Comptroller for certain S.U.N.Y. and C.U.N.Y. contracts), or if this is an amendment for any amount to a contract which, as so amended, exceeds said statutory amount, or if, by this contract, the State agrees to give something other than money when the value or reasonably estimated value of such consideration exceeds \$10,000, it shall not be valid, effective or binding upon the State until it has been approved by the State Comptroller and filed in his office. Comptroller's approval of contracts let by the Office of General Services is required when such contracts exceed \$85,000 (State Finance Law Section 163.6-a). However, such pre-approval shall not be required for any contract established as a centralized contract through the Office of General Services or for a purchase order or other transaction issued under such centralized contract.

4. WORKERS' COMPENSATION BENEFITS. In accordance with Section 142 of the State Finance Law, this

contract shall be void and of no force and effect unless the Contractor shall provide and maintain coverage during the life of this contract for the benefit of such employees as are required to be covered by the provisions of the Workers' Compensation Law.

5. NON-DISCRIMINATION REQUIREMENTS. To the extent required by Article 15 of the Executive Law (also known as the Human Rights Law) and all other State and Federal statutory and constitutional non-discrimination provisions, the Contractor will not discriminate against any employee or applicant for employment because of race, creed, color, sex (including gender identity or expression), national origin, sexual orientation, military status, age, disability, predisposing genetic characteristics, marital status or domestic violence victim status. Furthermore, in accordance with Section 220-e of the Labor Law, if this is a contract for the construction, alteration or repair of any public building or public work or for the manufacture, sale or distribution of materials, equipment or supplies, and to the extent that this contract shall be performed within the State of New York, Contractor agrees that neither it nor its subcontractors shall, by reason of race, creed, color, disability, sex, or national origin: (a) discriminate in hiring against any New York State citizen who is qualified and available to perform the work; or (b) discriminate against or intimidate any employee hired for the performance of work under this contract. If this is a building service contract as defined in Section 230 of the Labor Law, then, in accordance with Section 239 thereof, Contractor agrees that neither it nor its subcontractors shall by reason of race, creed, color, national origin, age, sex or disability: (a) discriminate in hiring against any New York State citizen who is qualified and available to perform the work; or (b) discriminate against or intimidate any employee hired for the performance of work under this contract. Contractor is subject to fines of \$50.00 per person per day for any violation of Section 220-e or Section 239 as well as possible termination of this contract and forfeiture of all moneys due hereunder for a second or subsequent violation.

6. WAGE AND HOURS PROVISIONS. If this is a public work contract covered by Article 8 of the Labor Law or a building service contract covered by Article 9 thereof, neither Contractor's employees nor the employees of its subcontractors may be required or permitted to work more than the number of hours or days stated in said statutes, except as otherwise provided in the Labor Law and as set forth in prevailing wage and supplement schedules issued by the State Labor Department. Furthermore, Contractor and its subcontractors must pay at least the prevailing wage rate and pay or provide the prevailing supplements, including the premium rates for overtime pay, as determined by the State Labor Department in accordance with the Labor Law. Additionally, effective April 28, 2008, if this is a public work contract covered by Article 8 of the Labor Law, the Contractor understands and agrees that the filing of payrolls in a manner consistent with Subdivision 3-a of Section 220 of the Labor Law shall be a condition precedent to payment by the State of

any State approved sums due and owing for work done upon the project.

7. NON-COLLUSIVE BIDDING CERTIFICATION. In accordance with Section 139-d of the State Finance Law, if this contract was awarded based upon the submission of bids, Contractor affirms, under penalty of perjury, that its bid was arrived at independently and without collusion aimed at restricting competition. Contractor further affirms that, at the time Contractor submitted its bid, an authorized and responsible person executed and delivered to the State a non-collusive bidding certification on Contractor's behalf.

8. INTERNATIONAL BOYCOTT PROHIBITION. In accordance with Section 220-f of the Labor Law and Section 139-h of the State Finance Law, if this contract exceeds \$5,000, the Contractor agrees, as a material condition of the contract, that neither the Contractor nor any substantially owned or affiliated person, firm, partnership or corporation has participated, is participating, or shall participate in an international boycott in violation of the federal Export Administration Act of 1979 (50 USC App. Sections 2401 et seq.) or regulations thereunder. If such Contractor, or any of the aforesaid affiliates of Contractor, is convicted or is otherwise found to have violated said laws or regulations upon the final determination of the United States Commerce Department or any other appropriate agency of the United States subsequent to the contract's execution, such contract, amendment or modification thereto shall be rendered forfeit and void. The Contractor shall so notify the State Comptroller within five (5) business days of such conviction, determination or disposition of appeal (2NYCRR 105.4).

9. SET-OFF RIGHTS. The State shall have all of its common law, equitable and statutory rights of set-off. These rights shall include, but not be limited to, the State's option to withhold for the purposes of set-off any moneys due to the Contractor under this contract up to any amounts due and owing to the State with regard to this contract, any other contract with any State department or agency, including any contract for a term commencing prior to the term of this contract, plus any amounts due and owing to the State for any other reason including, without limitation, tax delinquencies, fee delinquencies or monetary penalties relative thereto. The State shall exercise its set-off rights in accordance with normal State practices including, in cases of set-off pursuant to an audit, the finalization of such audit by the State agency, its representatives, or the State Comptroller.

10. RECORDS. The Contractor shall establish and maintain complete and accurate books, records, documents, accounts and other evidence directly pertinent to performance under this contract (hereinafter, collectively, "the Records"). The Records must be kept for the balance of the calendar year in which they were made and for six (6) additional years thereafter. The State Comptroller, the Attorney General and any other person or entity authorized to conduct an examination, as well as the agency or agencies involved in this

contract, shall have access to the Records during normal business hours at an office of the Contractor within the State of New York or, if no such office is available, at a mutually agreeable and reasonable venue within the State, for the term specified above for the purposes of inspection, auditing and copying. The State shall take reasonable steps to protect from public disclosure any of the Records which are exempt from disclosure under Section 87 of the Public Officers Law (the "Statute") provided that: (i) the Contractor shall timely inform an appropriate State official, in writing, that said records should not be disclosed; and (ii) said records shall be sufficiently identified; and (iii) designation of said records as exempt under the Statute is reasonable. Nothing contained herein shall diminish, or in any way adversely affect, the State's right to discovery in any pending or future litigation.

11. IDENTIFYING INFORMATION AND PRIVACY NOTIFICATION. (a) Identification Number(s). Every invoice or New York State Claim for Payment submitted to a New York State agency by a payee, for payment for the sale of goods or services or for transactions (e.g., leases, easements, licenses, etc.) related to real or personal property must include the payee's identification number. The number is any or all of the following: (i) the payee's Federal employer identification number, (ii) the payee's Federal social security number, and/or (iii) the payee's Vendor Identification Number assigned by the Statewide Financial System. Failure to include such number or numbers may delay payment. Where the payee does not have such number or numbers, the payee, on its invoice or Claim for Payment, must give the reason or reasons why the payee does not have such number or numbers.

(b) Privacy Notification. (1) The authority to request the above personal information from a seller of goods or services or a lessor of real or personal property, and the authority to maintain such information, is found in Section 5 of the State Tax Law. Disclosure of this information by the seller or lessor to the State is mandatory. The principal purpose for which the information is collected is to enable the State to identify individuals, businesses and others who have been delinquent in filing tax returns or may have understated their tax liabilities and to generally identify persons affected by the taxes administered by the Commissioner of Taxation and Finance. The information will be used for tax administration purposes and for any other purpose authorized by law. (2) The personal information is requested by the purchasing unit of the agency contracting to purchase the goods or services or lease the real or personal property covered by this contract or lease. The information is maintained in the Statewide Financial System by the Vendor Management Unit within the Bureau of State Expenditures, Office of the State Comptroller, 110 State Street, Albany, New York 12236.

12. EQUAL EMPLOYMENT OPPORTUNITIES FOR MINORITIES AND WOMEN. In accordance with Section 312 of the Executive Law and 5 NYCRR 143, if this contract is: (i) a written agreement or purchase order instrument, providing for a total expenditure in excess of \$25,000.00,

whereby a contracting agency is committed to expend or does expend funds in return for labor, services, supplies, equipment, materials or any combination of the foregoing, to be performed for, or rendered or furnished to the contracting agency; or (ii) a written agreement in excess of \$100,000.00 whereby a contracting agency is committed to expend or does expend funds for the acquisition, construction, demolition, replacement, major repair or renovation of real property and improvements thereon; or (iii) a written agreement in excess of \$100,000.00 whereby the owner of a State assisted housing project is committed to expend or does expend funds for the acquisition, construction, demolition, replacement, major repair or renovation of real property and improvements thereon for such project, then the following shall apply and by signing this agreement the Contractor certifies and affirms that it is Contractor's equal employment opportunity policy that:

(a) The Contractor will not discriminate against employees or applicants for employment because of race, creed, color, national origin, sex, age, disability or marital status, shall make and document its conscientious and active efforts to employ and utilize minority group members and women in its work force on State contracts and will undertake or continue existing programs of affirmative action to ensure that minority group members and women are afforded equal employment opportunities without discrimination. Affirmative action shall mean recruitment, employment, job assignment, promotion, upgradings, demotion, transfer, layoff, or termination and rates of pay or other forms of compensation;

(b) at the request of the contracting agency, the Contractor shall request each employment agency, labor union, or authorized representative of workers with which it has a collective bargaining or other agreement or understanding, to furnish a written statement that such employment agency, labor union or representative will not discriminate on the basis of race, creed, color, national origin, sex, age, disability or marital status and that such union or representative will affirmatively cooperate in the implementation of the Contractor's obligations herein; and

(c) the Contractor shall state, in all solicitations or advertisements for employees, that, in the performance of the State contract, all qualified applicants will be afforded equal employment opportunities without discrimination because of race, creed, color, national origin, sex, age, disability or marital status.

Contractor will include the provisions of "a", "b", and "c" above, in every subcontract over \$25,000.00 for the construction, demolition, replacement, major repair, renovation, planning or design of real property and improvements thereon (the "Work") except where the Work is for the beneficial use of the Contractor. Section 312 does not apply to: (i) work, goods or services unrelated to this contract; or (ii) employment outside New York State. The State shall consider compliance by a contractor or subcontractor with the requirements of any federal law concerning equal employment

opportunity which effectuates the purpose of this section. The contracting agency shall determine whether the imposition of the requirements of the provisions hereof duplicate or conflict with any such federal law and if such duplication or conflict exists, the contracting agency shall waive the applicability of Section 312 to the extent of such duplication or conflict. Contractor will comply with all duly promulgated and lawful rules and regulations of the Department of Economic Development's Division of Minority and Women's Business Development pertaining hereto.

13. CONFLICTING TERMS. In the event of a conflict between the terms of the contract (including any and all attachments thereto and amendments thereof) and the terms of this Appendix A, the terms of this Appendix A shall control.

14. GOVERNING LAW. This contract shall be governed by the laws of the State of New York except where the Federal supremacy clause requires otherwise.

15. LATE PAYMENT. Timeliness of payment and any interest to be paid to Contractor for late payment shall be governed by Article 11-A of the State Finance Law to the extent required by law.

16. NO ARBITRATION. Disputes involving this contract, including the breach or alleged breach thereof, may not be submitted to binding arbitration (except where statutorily authorized), but must, instead, be heard in a court of competent jurisdiction of the State of New York.

17. SERVICE OF PROCESS. In addition to the methods of service allowed by the State Civil Practice Law & Rules ("CPLR"), Contractor hereby consents to service of process upon it by registered or certified mail, return receipt requested. Service hereunder shall be complete upon Contractor's actual receipt of process or upon the State's receipt of the return thereof by the United States Postal Service as refused or undeliverable. Contractor must promptly notify the State, in writing, of each and every change of address to which service of process can be made. Service by the State to the last known address shall be sufficient. Contractor will have thirty (30) calendar days after service hereunder is complete in which to respond.

18. PROHIBITION ON PURCHASE OF TROPICAL HARDWOODS. The Contractor certifies and warrants that all wood products to be used under this contract award will be in accordance with, but not limited to, the specifications and provisions of Section 165 of the State Finance Law, (Use of Tropical Hardwoods) which prohibits purchase and use of tropical hardwoods, unless specifically exempted, by the State or any governmental agency or political subdivision or public benefit corporation. Qualification for an exemption under this law will be the responsibility of the contractor to establish to meet with the approval of the State.

In addition, when any portion of this contract involving the use of woods, whether supply or installation, is to be performed by any subcontractor, the prime Contractor will indicate and certify in the submitted bid proposal that the subcontractor has been informed and is in compliance with specifications and provisions regarding use of tropical hardwoods as detailed in §165 State Finance Law. Any such use must meet with the approval of the State; otherwise, the bid may not be considered responsive. Under bidder certifications, proof of qualification for exemption will be the responsibility of the Contractor to meet with the approval of the State.

19. MACBRIDE FAIR EMPLOYMENT PRINCIPLES.

In accordance with the MacBride Fair Employment Principles (Chapter 807 of the Laws of 1992), the Contractor hereby stipulates that the Contractor either (a) has no business operations in Northern Ireland, or (b) shall take lawful steps in good faith to conduct any business operations in Northern Ireland in accordance with the MacBride Fair Employment Principles (as described in Section 165 of the New York State Finance Law), and shall permit independent monitoring of compliance with such principles.

20. OMNIBUS PROCUREMENT ACT OF 1992. It is the policy of New York State to maximize opportunities for the participation of New York State business enterprises, including minority and women-owned business enterprises as bidders, subcontractors and suppliers on its procurement contracts.

Information on the availability of New York State subcontractors and suppliers is available from:

NYS Department of Economic Development
Division for Small Business
Albany, New York 12245
Telephone: 518-292-5100
Fax: 518-292-5884
email: opa@esd.ny.gov

A directory of certified minority and women-owned business enterprises is available from:

NYS Department of Economic Development
Division of Minority and Women's Business Development
633 Third Avenue
New York, NY 10017
212-803-2414
email: mwbecertification@esd.ny.gov
<https://ny.newnycontracts.com/FrontEnd/VendorSearchPublic.asp>

The Omnibus Procurement Act of 1992 requires that by signing this bid proposal or contract, as applicable, Contractors certify that whenever the total bid amount is greater than \$1 million:

(a) The Contractor has made reasonable efforts to encourage the participation of New York State Business Enterprises as suppliers and subcontractors, including certified minority and women-owned business enterprises, on this project, and has retained the documentation of these efforts to be provided upon request to the State;

(b) The Contractor has complied with the Federal Equal Opportunity Act of 1972 (P.L. 92-261), as amended;

(c) The Contractor agrees to make reasonable efforts to provide notification to New York State residents of employment opportunities on this project through listing any such positions with the Job Service Division of the New York State Department of Labor, or providing such notification in such manner as is consistent with existing collective bargaining contracts or agreements. The Contractor agrees to document these efforts and to provide said documentation to the State upon request; and

(d) The Contractor acknowledges notice that the State may seek to obtain offset credits from foreign countries as a result of this contract and agrees to cooperate with the State in these efforts.

21. RECIPROCITY AND SANCTIONS PROVISIONS.

Bidders are hereby notified that if their principal place of business is located in a country, nation, province, state or political subdivision that penalizes New York State vendors, and if the goods or services they offer will be substantially produced or performed outside New York State, the Omnibus Procurement Act 1994 and 2000 amendments (Chapter 684 and Chapter 383, respectively) require that they be denied contracts which they would otherwise obtain. NOTE: As of May 15, 2002, the list of discriminatory jurisdictions subject to this provision includes the states of South Carolina, Alaska, West Virginia, Wyoming, Louisiana and Hawaii. Contact NYS Department of Economic Development for a current list of jurisdictions subject to this provision.

22. COMPLIANCE WITH NEW YORK STATE INFORMATION SECURITY BREACH AND NOTIFICATION ACT.

Contractor shall comply with the provisions of the New York State Information Security Breach and Notification Act (General Business Law Section 899-aa; State Technology Law Section 208).

23. COMPLIANCE WITH CONSULTANT DISCLOSURE LAW.

If this is a contract for consulting services, defined for purposes of this requirement to include analysis, evaluation, research, training, data processing, computer programming, engineering, environmental, health, and mental health services, accounting, auditing, paralegal, legal or similar services, then, in accordance with Section 163 (4-g) of the State Finance Law (as amended by Chapter 10 of the Laws of 2006), the Contractor shall timely, accurately and properly comply with the requirement to submit an annual employment report for the contract to the agency that awarded

the contract, the Department of Civil Service and the State Comptroller.

24. PROCUREMENT LOBBYING. To the extent this agreement is a "procurement contract" as defined by State Finance Law Sections 139-j and 139-k, by signing this agreement the contractor certifies and affirms that all disclosures made in accordance with State Finance Law Sections 139-j and 139-k are complete, true and accurate. In the event such certification is found to be intentionally false or intentionally incomplete, the State may terminate the agreement by providing written notification to the Contractor in accordance with the terms of the agreement.

25. CERTIFICATION OF REGISTRATION TO COLLECT SALES AND COMPENSATING USE TAX BY CERTAIN STATE CONTRACTORS, AFFILIATES AND SUBCONTRACTORS.

To the extent this agreement is a contract as defined by Tax Law Section 5-a, if the contractor fails to make the certification required by Tax Law Section 5-a or if during the term of the contract, the Department of Taxation and Finance or the covered agency, as defined by Tax Law 5-a, discovers that the certification, made under penalty of perjury, is false, then such failure to file or false certification shall be a material breach of this contract and this contract may be terminated, by providing written notification to the Contractor in accordance with the terms of the agreement, if the covered agency determines that such action is in the best interest of the State.

26. IRAN DIVESTMENT ACT. By entering into this Agreement, Contractor certifies in accordance with State Finance Law §165-a that it is not on the "Entities Determined to be Non-Responsive Bidders/Offerers pursuant to the New York State Iran Divestment Act of 2012" ("Prohibited Entities List") posted at:
<http://www.ogs.ny.gov/about/regs/docs/ListofEntities.pdf>

Contractor further certifies that it will not utilize on this Contract any subcontractor that is identified on the Prohibited Entities List. Contractor agrees that should it seek to renew or extend this Contract, it must provide the same certification at the time the Contract is renewed or extended. Contractor also agrees that any proposed Assignee of this Contract will be required to certify that it is not on the Prohibited Entities List before the contract assignment will be approved by the State.

During the term of the Contract, should the state agency receive information that a person (as defined in State Finance Law §165-a) is in violation of the above-referenced certifications, the state agency will review such information and offer the person an opportunity to respond. If the person fails to demonstrate that it has ceased its engagement in the investment activity which is in violation of the Act within 90 days after the determination of such violation, then the state agency shall take such action as may be appropriate and provided for by law, rule, or contract, including, but not

limited to, imposing sanctions, seeking compliance, recovering damages, or declaring the Contractor in default.

The state agency reserves the right to reject any bid, request for assignment, renewal or extension for an entity that appears on the Prohibited Entities List prior to the award, assignment, renewal or extension of a contract, and to pursue a responsibility review with respect to any entity that is awarded a contract and appears on the Prohibited Entities list after contract award.

APPENDIX B
REQUIREMENTS FOR FEDERALLY-AIDED TRANSPORTATION PROJECTS
(June 2016)

There is a substantial body of requirements attached to the use of Federal highway or transportation aid. These requirements create or overlay processes, procedures, documentation requirements, authorizations, approvals and certifications that may be substantially greater or different from those that are not funded with Federal-aid and proceed under applicable State and local laws, customs and practices. Under Title 23 of the United States Code, the New York State Department of Transportation (NYSDOT) is responsible for the administration of transportation projects in New York State to which NYSDOT provides Federal highway or transportation-related aid. Through this Agreement, which provides or is associated with such funding, NYSDOT delegates various elements of project and funding administration as described elsewhere in this Agreement. In undertaking a Federally aided project, the Municipality/Sponsor, Authority or Project Manager designated under this Agreement with Federal-aid funding or project administration agrees to proceed in compliance with all the applicable Federal-aid requirements.

NYSDOT, in cooperation with FHWA, has assembled the body of Federal-aid requirements, procedures and practices in its Procedures for Locally Administered Federal-Aid Projects Manual (available through NYSDOT's web site at: <http://www.dot.ny.gov/plafap>). In addition, the Municipality/Sponsor, Authority or Project Manager designated under this Agreement for Federal-aid funding or project administration that enters into Federally aided project construction contracts is required to physically incorporate into all its Federally aided construction contracts and subcontracts there under the provisions that are contained in Form FHWA-1273 (available from NYSDOT or electronically at: <http://www.fhwa.dot.gov/programadmin/contracts/1273.htm>).

In addition to the referenced requirements, the attention of Municipality/Sponsor hereunder is directed to the following requirements and information:

NON DISCRIMINATION/EEO/DBE REQUIREMENTS

The Municipality/Sponsor and its contractors agree to comply with Executive Order 11246, entitled "Equal Employment Opportunity" and United States Department of Transportation (USDOT) regulations (49 CFR Parts 21, 23, 25, 26 and 27) and the following:

1. **NON DISCRIMINATION**. No person shall, on the ground of race, color, creed, national origin, sex, age or handicap, be excluded from participation in, or denied the benefits of, or be subject to, discrimination under the Project funded through this Agreement.
2. **EQUAL EMPLOYMENT OPPORTUNITY**. In connection with the execution of this Agreement, the Municipality/Sponsors contractors or subcontractors shall not discriminate against any employee or applicant for employment because of race, religion, age, color, sex or national origin. Such contractors shall take affirmative actions to ensure that applicants are employed, and that employees are treated during their employment, without regard to their race, religion, color, sex, national origin or age. Such actions shall include, but not be limited to, the following: employment, upgrading, demotion or transfer; recruitment or recruitment advertising; layoff or termination; rates of pay or other forms of compensation; and selection for training, including apprenticeship.

3. **DISADVANTAGED BUSINESS ENTERPRISES**. In connection with the performance of this Agreement, the Municipality/Sponsor shall cause its contractors to cooperate with the State in meeting its commitments and goals with regard to the utilization of Disadvantaged Business Enterprises (DBEs) and will use its best efforts to ensure that DBEs will have opportunity to compete for subcontract work under this Agreement. Also, in this connection the Municipality or Municipality/Sponsor shall cause its contractors to undertake such actions as may be necessary to comply with 49 CFR Part 26.

As a sub-recipient under 49 CFR Part 26.13, the Municipality/Sponsor hereby makes the following assurance.

The Municipality/Sponsor shall not discriminate on the basis of race, color, national origin, or sex in the award and performance of any United States Department of Transportation (USDOT)-assisted contract or in the administration of its Disadvantaged Business Enterprise (DBE) program or the requirements of 49 CFR Part 26. The Municipality/Sponsor shall take all necessary and reasonable steps under 49 CFR Part 26 to ensure nondiscrimination in the award and administration of the United States Department of Transportation-assisted contracts. The New York State Department of Transportation's DBE program, as required by 49 CFR Part 26 and as approved by the United States Department of Transportation, is incorporated by reference in this agreement. Implementation of this program is a legal obligation and failure to carry out its terms shall be treated as a violation of this agreement. Upon notification to the recipient of its failure to carry out its approved program, the USDOT may impose sanctions as provided for under part 26 and may, in appropriate cases, refer the matter for enforcement under 18 U.S.C. 1001 and/or the Program Fraud Civil Remedies Act of 1986 (31 U.S.C. 3801 et seq.).

FEDERAL SINGLE AUDIT REQUIREMENTS

Non-Federal entities that expend \$750,000 or more in a year in Federal awards from all sources are required to comply with the Federal Single Audit Act provisions contained in U.S. Office of Management and Budget (OMB) Circular No. A-133, Audits of States, Local Governments, and Non-Profit Organizations. Non-Federal entities that expend Federal awards from a single source may provide a program specific audit, as defined in the Circular. Non-Federal entities that expend less than the amount above in a year in Federal awards from all sources are exempt from Federal audit requirements for that year, except as noted in Sec. 215 (a) of OMB Circular A-133 Subpart B--Audits, records must be available for review or audit by appropriate officials of the cognizant Federal agency¹ the New York State Department of Transportation, the New York State Comptrollers Office and the U.S. Governmental Accountability Office (GAO).

Non-Federal entities are required to submit a copy of all audits, as described above, within 30 days of issuance of audit report, but no later than 9 months after the end of the entity's fiscal year, to the New York State Department of Transportation, Contract Audit Bureau, 50 Wolf Road, Albany, NY 12232. Unless a time extension has been granted by the cognizant Federal Agency and has been filed with the New York State Department of Transportation's Contract Audit Bureau, failure to comply with the requirements of OMB Circular A-133 may result in suspension or termination of Federal award payments.

¹ The designated cognizant agency for audit shall be the federal awarding agency that provides the predominant amount of direct funding to a recipient unless OMB changes it.

THE CATALOG OF FEDERAL DOMESTIC ASSISTANCE

The Catalog of Federal Domestic Assistance (CFDA²), is an on-line database of all Federally-aided programs available to State and local governments (including the District of Columbia); Federally recognized Indian tribal governments; Territories (and possessions) of the United States; domestic public, quasi-public, and private profit and nonprofit organizations and institutions; specialized groups; and individuals.

THE CFDA IDENTIFICATION NUMBER

OMB Circular A-133 requires all Federal-aid recipients to identify and account for awards and expenditures by CFDA Number. The Municipality/Sponsor is required to identify in its accounts all Federal awards received and expended, and the Federal programs under which they were received. Federal program and award identification shall include, as applicable, the CFDA title and number, award number and year, name of the Federal agency, and name of the pass-through entity.

The most commonly used CFDA number for the Federal Aid Highway Planning and Construction program is 20.205.

Additional CFDA numbers for other transportation and non-transportation related programs are:

- 20.215 Highway Training and Education**
- 20.219 Recreational Trails Program**
- 20.XXX Highway Planning and Construction - Highways for LIFE;**
- 20.XXX Surface Transportation Research and Development;**
- 20.500 Federal Transit-Capital Investment Grants**
- 20.505 Federal Transit-Metropolitan Planning Grants**
- 20.507 Federal Transit-Formula Grants**
- 20.509 Formula Grants for Other Than Urbanized Areas**
- 20.600 State and Community Highway Safety**
- 23.003 Appalachian Development Highway System**
- 23.008 Appalachian Local Access Roads,**

PROMPT PAYMENT MECHANISMS

In accordance with 49 CFR 26.29, and NY State Finance Law 139-f or NY General Municipal Law 106-b(2) as applicable:

(a) You must establish, as part of your DBE program, a contract clause to require prime contractors to pay subcontractors for satisfactory performance of their contracts no later than 7 calendar days from receipt of each payment you make to the prime contractor.

(b) You must ensure prompt and full payment of retainage from the prime contractor to the subcontractor within 7 calendar days after the subcontractor's work is satisfactorily completed.

You must use one of the following methods to comply with this requirement:

(1) You may decline to hold retainage from prime contractors and prohibit prime contractors from holding retainage from subcontractors.

(2) You may decline to hold retainage from prime contractors and require a contract clause obligating prime contractors to make prompt and full payment of any retainage kept by

² <http://www.cfda.gov/>

prime contractor to the subcontractor within 7 calendar days after the subcontractor's work is satisfactorily completed.

(3) You may hold retainage from prime contractors and provide for prompt and regular incremental acceptances of portions of the prime contract, pay retainage to prime contractors based on these acceptances, and require a contract clause obligating the prime contractor to pay all retainage owed to the subcontractor for satisfactory completion of the accepted work within 7 calendar days after your payment to the prime contractor.

(c) For purposes of this section, a subcontractor's work is satisfactorily completed when all the tasks called for in the subcontract have been accomplished and documented as required by the recipient. When a recipient has made an incremental acceptance of a portion of a prime contract, the work of a subcontractor covered by that acceptance is deemed to be satisfactorily completed.

(d) Your DBE program must provide appropriate means to enforce the requirements of this section. These means may include appropriate penalties for failure to comply, the terms and conditions of which you set. Your program may also provide that any delay or postponement of payment among the parties may take place only for good cause, with your prior written approval.

(e) You may also establish, as part of your DBE program, any of the following additional mechanisms to ensure prompt payment:

(1) A contract clause that requires prime contractors to include in their subcontracts language providing that prime contractors and subcontractors will use appropriate alternative dispute resolution mechanisms to resolve payment disputes. You may specify the nature of such mechanisms.

(2) A contract clause providing that the prime contractor will not be reimbursed for work performed by subcontractors unless and until the prime contractor ensures that the subcontractors are promptly paid for the work they have performed.

(3) Other mechanisms, consistent with this part and applicable state and local law, to ensure that DBEs and other contractors are fully and promptly paid.

CARGO PREFERENCE ACT REQUIREMENTS – U.S. FLAG VESSELS

In accordance with 46 CFR 381, the contractor agrees:

- (a) To utilize privately owned United States-flag commercial vessels to ship at least 50 percent of the gross tonnage (computed separately for dry bulk carriers, dry cargo liners, and tankers) involved, whenever shipping any equipment, material, or commodities pursuant to this contract, to the extent such vessels are available at fair and reasonable rates for United States-flag commercial vessels.
- (b) To furnish within 20 days following the date of loading for shipments originating within the United States or within 30 working days following the date of loading for shipments originating outside the United States, a legible copy of a rated, 'on-board' commercial ocean bill-of-lading in English for each shipment of cargo described in paragraph (b) (1) of this section to both the Contracting Officer (through the prime contractor in the case of subcontractor bills-of-lading) and to the Division of National Cargo, Office of Market Development, Maritime Administration, Washington, DC 20590.
- (c) To insert the substance of the provisions of this clause in all subcontracts issued pursuant to this contract.

CERTIFICATION OF OFFERER/BIDDER REGARDING DEBARMENT

Contractor/Consultant, by entering into this agreement, certifies that neither it nor its principals are presently debarred or suspended by any Federal department or agency from participation in this transaction.

CERTIFICATION OF LOWER TIER CONTRACTORS REGARDING DEBARMENT

The Contractor/Consultant, by administering each lower tier subcontract that exceeds \$25,000 as a "covered transaction", must verify each lower tier participant of a "covered transaction" under the project is not presently debarred or otherwise disqualified from participation in this federally assisted project. The successful bidder will accomplish this by:

1. Checking the System for Award Management at website: <http://www.sam.gov>.
2. Collecting a certification statement similar to the Certification of Offerer/Bidder Regarding Debarment, above.
3. Inserting a clause or condition in the covered transaction with the lower tier contract.

If the Federal Aviation Administration later determines that a lower tier participant failed to disclose to a higher tier participant that it was excluded or disqualified at the time it entered the covered transaction, the FAA may pursue any available remedies, including suspension and debarment of the non-compliant participant.



U.S. Department
of Transportation
**Federal Aviation
Administration**

FAA Form 5100-129, Construction Project Final Acceptance – Airport Improvement Program Sponsor Certification

Paperwork Reduction Act Burden Statement

A federal agency may not conduct or sponsor, and a person is not required to respond to, nor shall a person be subject to a penalty for failure to comply with a collection of information subject to the requirements of the Paperwork Reduction Act unless that collection of information displays a currently valid OMB Control Number. The OMB Control Number for this information collection is 2120-0569. Public reporting for this collection of information is estimated to be approximately 8 hours per response, including the time for reviewing instructions, searching existing data sources, gathering and maintaining the data needed, completing and reviewing the collection of information. All responses to this collection of information are required under 49 U.S.C. Section 47105 to retain a benefit and to meet the reporting requirements of 2 CFR 200. Send comments regarding this burden estimate or any other aspect of this collection of information, including suggestions for reducing this burden to: Information Collection Clearance Officer, Federal Aviation Administration, 10101 Hillwood Parkway, Fort Worth, TX 76177-1524.

Construction Project Final Acceptance Airport Improvement Program Sponsor Certification

Sponsor:

Airport:

Project Number:

Description of Work:

Application

49 USC § 47105(d), authorizes the Secretary to require me certification from the sponsor that it will comply with the statutory and administrative requirements in carrying out a project under the Airport Improvement Program. General standards for final acceptance and close out of federally funded construction projects are in 2 CFR § 200.343 – Closeout and supplemented by FAA Order 5100.38. The sponsor must determine that project costs are accurate and proper in accordance with specific requirements of the grant agreement and contract documents.

Certification Statements

Except for certification statements below marked not applicable (N/A), this list includes major requirements of the construction project. Selecting “Yes” represents sponsor acknowledgment and confirmation of the certification statement. The term “will” means Sponsor action taken at appropriate time based on the certification statement focus area, but no later than the end of the project period of performance. This list is not comprehensive and does not relieve the sponsor from fully complying with all applicable statutory and administrative standards. The source of the requirement is referenced within parenthesis.

1. The personnel engaged in project administration, engineering supervision, project inspection, and acceptance testing were or will be determined to be qualified and competent to perform the work (Grant Assurance).

Yes No N/A

2. Construction records, including daily logs, were or will be kept by the resident engineer/construction inspector that fully document contractor’s performance in complying with:
 - a. Technical standards (Advisory Circular (AC) 150/5370-12);
 - b. Contract requirements (2 CFR part 200 and FAA Order 5100.38); and
 - c. Construction safety and phasing plan measures (AC 150/5370-2).

Yes No N/A

3. All acceptance tests specified in the project specifications were or will be performed and documented. (AC 150/5370-12).

Yes No N/A

4. Sponsor has taken or will take appropriate corrective action for any test result outside of allowable tolerances (AC 150/5370-12).
- Yes No N/A
5. Pay reduction factors required by the specifications were applied or will be applied in computing final payments with a summary made available to the FAA (AC 150/5370-10).
- Yes No N/A
6. Sponsor has notified, or will promptly notify the Federal Aviation Administration (FAA) of the following occurrences:
- a. Violations of any federal requirements set forth or included by reference in the contract documents (2 CFR part 200);
 - b. Disputes or complaints concerning federal labor standards (29 CFR part 5); and
 - c. Violations of or complaints addressing conformance with Equal Employment Opportunity or Disadvantaged Business Enterprise requirements (41 CFR Chapter 60 and 49 CFR part 26).
- Yes No N/A
7. Weekly payroll records and statements of compliance were or will be submitted by the prime contractor and reviewed by the sponsor for conformance with federal labor and civil rights requirements as required by FAA and U.S. Department of Labor (29 CFR Part 5).
- Yes No N/A
8. Payments to the contractor were or will be made in conformance with federal requirements and contract provisions using sponsor internal controls that include:
- a. Retaining source documentation of payments and verifying contractor billing statements against actual performance (2 CFR § 200.302 and FAA Order 5100.38);
 - b. Prompt payment of subcontractors for satisfactory performance of work (49 CFR § 26.29);
 - c. Release of applicable retainage upon satisfactory performance of work (49 CFR § 26.29); and
 - d. Verification that payments to DBEs represent work the DBE performed by carrying out a commercially useful function (49 CFR §26.55).
- Yes No N/A
9. A final project inspection was or will be conducted with representatives of the sponsor and the contractor present that ensure:
- a. Physical completion of project work in conformance with approved plans and specifications (Order 5100.38);
 - b. Necessary actions to correct punch list items identified during final inspection are complete (Order 5100.38); and
 - c. Preparation of a record of final inspection and distribution to parties to the contract (Order 5100.38);
- Yes No N/A
10. The project was or will be accomplished without material deviations, changes, or modifications from approved plans and specifications, except as approved by the FAA (Order 5100.38).
- Yes No N/A

11. The construction of all buildings have complied or will comply with the seismic construction requirements of 49 CFR § 41.120.

Yes No N/A

12. For development projects, sponsor has taken or will take the following close-out actions:

- a. Submit to the FAA a final test and quality assurance report summarizing acceptance test results, as applicable (Grant Condition);
- b. Complete all environmental requirements as established within the project environmental determination (Order 5100.38); and
- c. Prepare and retain as-built plans (Order 5100.38).

Yes No N/A

13. Sponsor has revised or will revise their airport layout plan (ALP) that reflects improvements made and has submitted or will submit an updated ALP to the FAA no later than 90 days from the period of performance end date. (49 USC § 47107 and Order 5100.38).

Yes No N/A

Attach documentation clarifying any above item marked with "No" response.

Sponsor's Certification

I certify, for the project identified herein, responses to the forgoing items are accurate as marked and additional documentation for any item marked "no" is correct and complete.

Executed on this day of , .

Name of Sponsor:

Name of Sponsor's Authorized Official:

Title of Sponsor's Authorized Official:

Signature of Sponsor's Authorized Official: Philip F. Calderone

I declare under penalty of perjury that the foregoing is true and correct. I understand that knowingly and willfully providing false information to the federal government is a violation of 18 USC § 1001 (False Statements) and could subject me to fines, imprisonment, or both.



U.S. Department
of Transportation
**Federal Aviation
Administration**

FAA Form 5100-130, Drug-Free Workplace – Airport Improvement Program Sponsor Certification

Paperwork Reduction Act Burden Statement

A federal agency may not conduct or sponsor, and a person is not required to respond to, nor shall a person be subject to a penalty for failure to comply with a collection of information subject to the requirements of the Paperwork Reduction Act unless that collection of information displays a currently valid OMB Control Number. The OMB Control Number for this information collection is 2120-0569. Public reporting for this collection of information is estimated to be approximately 8 hours per response, including the time for reviewing instructions, searching existing data sources, gathering and maintaining the data needed, completing and reviewing the collection of information. All responses to this collection of information are required under 49 U.S.C. Section 47105 to retain a benefit and to meet the reporting requirements of 2 CFR 200. Send comments regarding this burden estimate or any other aspect of this collection of information, including suggestions for reducing this burden to: Information Collection Clearance Officer, Federal Aviation Administration, 10101 Hillwood Parkway, Fort Worth, TX 76177-1524.



Drug-Free Workplace Airport Improvement Program Sponsor Certification

Sponsor:

Airport:

Project Number:

Description of Work:

Application

49 USC § 47105(d) authorizes the Secretary to require certification from the sponsor that it will comply with the statutory and administrative requirements in carrying out a project under the Airport Improvement Program (AIP). General requirements on the drug-free workplace within federal grant programs are described in 2 CFR part 182. Sponsors are required to certify they will be, or will continue to provide, a drug-free workplace in accordance with the regulation. The AIP project grant agreement contains specific assurances on the Drug-Free Workplace Act of 1988.

Certification Statements

Except for certification statements below marked as not applicable (N/A), this list includes major requirements of the construction project. Selecting “Yes” represents sponsor acknowledgement and confirmation of the certification statement. The term “will” means Sponsor action taken at appropriate time based on the certification statement focus area, but no later than the end of the project period of performance. This list is not comprehensive and does not relieve the sponsor from fully complying with all applicable statutory and administrative standards. The source of the requirement is referenced within parenthesis.

1. A statement has been or will be published prior to commencement of project notifying employees that the unlawful manufacture, distribution, dispensing, possession, or use of a controlled substance is prohibited in the sponsor's workplace, and specifying the actions to be taken against employees for violation of such prohibition (2 CFR § 182.205).

Yes No N/A

2. An ongoing drug-free awareness program (2 CFR § 182.215) has been or will be established prior to commencement of project to inform employees about:
 - a. The dangers of drug abuse in the workplace;
 - b. The sponsor's policy of maintaining a drug-free workplace;
 - c. Any available drug counseling, rehabilitation, and employee assistance programs; and
 - d. The penalties that may be imposed upon employees for drug abuse violations occurring in the workplace.

Yes No N/A

3. Each employee to be engaged in the performance of the work has been or will be given a copy of the statement required within item 1 above prior to commencement of project (2 CFR § 182.210).

Yes No N/A

4. Employees have been or will be notified in the statement required by item 1 above that, as a condition employment under the grant (2 CFR § 182.205(c)), the employee will:

- a. Abide by the terms of the statement; and
- b. Notify the employer in writing of his or her conviction for a violation of a criminal drug statute occurring in the workplace no later than five calendar days after such conviction.

Yes No N/A

5. The Federal Aviation Administration (FAA) will be notified in writing within 10 calendar days after receiving notice under item 4b above from an employee or otherwise receiving actual notice of such conviction (2 CFR § 182.225). Employers of convicted employees must provide notice, including position title of the employee, to the FAA (2 CFR § 182.300).

Yes No N/A

6. One of the following actions (2 CFR § 182.225(b)) will be taken within 30 calendar days of receiving a notice under item 4b above with respect to any employee who is so convicted:

- a. Take appropriate personnel action against such an employee, up to and including termination, consistent with the requirements of the Rehabilitation Act of 1973, as amended; and
- b. Require such employee to participate satisfactorily in drug abuse assistance or rehabilitation programs approved for such purposes by a federal, state, or local health, law enforcement, or other appropriate agency.

Yes No N/A

7. A good faith effort will be made, on a continuous basis, to maintain a drug-free workplace through implementation of items 1 through 6 above (2 CFR § 182.200).

Yes No N/A

Site(s) of performance of work (2 CFR § 182.230):

Location 1

Name of Location:

Address:

Location 2 (if applicable)

Name of Location:

Address:

Location 3 (if applicable)

Name of Location:

Address:

Attach documentation clarifying any above item marked with a "No" response.

Sponsor's Certification

I certify, for the project identified herein, responses to the forgoing items are accurate as marked and additional documentation for any item marked "no" is correct and complete.

Executed on this day of , .

Name of Sponsor:

Name of Sponsor's Authorized Official:

Title of Sponsor's Authorized Official:

Signature of Sponsor's Authorized Official: Philip F. Calderone

I declare under penalty of perjury that the foregoing is true and correct. I understand that knowingly and willfully providing false information to the federal government is a violation of 18 USC § 1001 (False Statements) and could subject me to fines, imprisonment, or both.



U.S. Department
of Transportation
**Federal Aviation
Administration**

FAA Form 5100-131, Equipment and Construction Contracts – Airport Improvement Sponsor Certification

Paperwork Reduction Act Burden Statement

A federal agency may not conduct or sponsor, and a person is not required to respond to, nor shall a person be subject to a penalty for failure to comply with a collection of information subject to the requirements of the Paperwork Reduction Act unless that collection of information displays a currently valid OMB Control Number. The OMB Control Number for this information collection is 2120-0569. Public reporting for this collection of information is estimated to be approximately 8 hours per response, including the time for reviewing instructions, searching existing data sources, gathering and maintaining the data needed, completing and reviewing the collection of information. All responses to this collection of information are required under 49 U.S.C. Section 47105 to retain a benefit and to meet the reporting requirements of 2 CFR 200. Send comments regarding this burden estimate or any other aspect of this collection of information, including suggestions for reducing this burden to: Information Collection Clearance Officer, Federal Aviation Administration, 10101 Hillwood Parkway, Fort Worth, TX 76177-1524.



Equipment and Construction Contracts Airport Improvement Sponsor Certification

Sponsor:

Airport:

Project Number:

Description of Work:

Application

49 USC § 47105(d) authorizes the Secretary to require certification from the sponsor that it will comply with the statutory and administrative requirements in carrying out a project under the Airport Improvement Program (AIP). General procurement standards for equipment and construction contracts within Federal grant programs are described in 2 CFR §§ 200.317-200.326. Labor and Civil Rights Standards applicable to the AIP are established by the Department of Labor (www.dol.gov) AIP Grant Assurance C.1—General Federal Requirements identifies all applicable Federal Laws, regulations, executive orders, policies, guidelines and requirements for assistance under the AIP. Sponsors may use state and local procedures provided the procurement conforms to these federal standards.

This certification applies to all equipment and construction projects. Equipment projects may or may not employ laborers and mechanics that qualify the project as a “covered contract” under requirements established by the Department of Labor requirements. Sponsor shall provide appropriate responses to the certification statements that reflect the character of the project regardless of whether the contract is for a construction project or an equipment project.

Certification Statements

Except for certification statements below marked as not applicable (N/A), this list includes major requirements of the construction project. Selecting “Yes” represents sponsor acknowledgement and confirmation of the certification statement. The term “will” means Sponsor action taken at appropriate time based on the certification statement focus area, but no later than the end of the project period of performance. This list is not comprehensive and does not relieve the sponsor from fully complying with all applicable statutory and administrative standards. The source of the requirement is referenced within parenthesis.

1. A written code or standard of conduct is or will be in effect prior to commencement of the project that governs the performance of the sponsor’s officers, employees, or agents in soliciting, awarding and administering procurement contracts (2 CFR § 200.318).

Yes	No	N/A
-----	----	-----

2. For all contracts, qualified and competent personnel are or will be engaged to perform contract administration, engineering supervision, construction inspection, and testing (Grant Assurance C.17).

Yes No N/A

3. Sponsors that are required to have a Disadvantage Business Enterprise (DBE) program on file with the FAA have included or will include clauses required by Title VI of the Civil Rights Act and 49 CFR Part 26 for Disadvantaged Business Enterprises in all contracts and subcontracts.

Yes No N/A

4. Sponsors required to have a DBE program on file with the FAA have implemented or will implement monitoring and enforcement measures that:

- a. Ensure work committed to Disadvantaged Business Enterprises at contract award is actually performed by the named DBEs (49 CFR § 26.37(b));
- b. Include written certification that the sponsor has reviewed contract records and has monitored work sites for performance by DBE firms (49 CFR § 26.37(b)); and
- c. Provides for a running tally of payments made to DBE firms and a means for comparing actual attainments (i.e. payments) to original commitments (49 CFR § 26.37(c)).

Yes No N/A

5. Sponsor procurement actions using the competitive sealed bid method (2 CFR § 200.320(c)). was or will be:

- a. Publicly advertised, allowing a sufficient response time to solicit an adequate number of interested contractors or vendors;
- b. Prepared to include a complete, adequate and realistic specification that defines the items or services in sufficient detail to allow prospective bidders to respond;
- c. Publicly opened at a time and place prescribed in the invitation for bids; and
- d. Prepared in a manner that result in a firm fixed price contract award to the lowest responsive and responsible bidder.

Yes No N/A

6. For projects the Sponsor proposes to use the competitive proposal procurement method (2 CFR § 200.320(d)), Sponsor has requested or will request FAA approval prior to proceeding with a competitive proposal procurement by submitting to the FAA the following:

- a. Written justification that supports use of competitive proposal method in lieu of the preferred sealed bid procurement method;
- b. Plan for publicizing and soliciting an adequate number of qualified sources; and
- c. Listing of evaluation factors along with relative importance of the factors.

Yes No N/A

7. For construction and equipment installation projects, the bid solicitation includes or will include the current federal wage rate schedule(s) for the appropriate type of work classifications (2 CFR Part 200, Appendix II).

Yes No N/A

8. Concurrence was or will be obtained from the Federal Aviation Administration (FAA) prior to contract award under any of the following circumstances (Order 5100.38D):

- a. Only one qualified person/firm submits a responsive bid;
- b. Award is to be made to other than the lowest responsible bidder; and
- c. Life cycle costing is a factor in selecting the lowest responsive bidder.

Yes No N/A

9. All construction and equipment installation contracts contain or will contain provisions for:

- a. Access to Records (§ 200.336)
- b. Buy American Preferences (Title 49 U.S.C. § 50101)
- c. Civil Rights - General Provisions and Title VI Assurances(41 CFR part 60)
- d. Federal Fair Labor Standards (29 U.S.C. § 201, et seq)
- e. Occupational Safety and Health Act requirements (20 CFR part 1920)
- f. Seismic Safety – building construction (49 CFR part 41)
- g. State Energy Conservation Requirements - as applicable(2 CFR part 200, Appendix II)
- h. U.S. Trade Restriction (49 CFR part 30)
- i. Veterans Preference (49 USC § 47112(c))

Yes No N/A

10. All construction and equipment installation contracts exceeding \$2,000 contain or will contain the provisions established by:

- a. Davis-Bacon and Related Acts (29 CFR part 5)
- b. Copeland “Anti-Kickback” Act (29 CFR parts 3 and 5)

Yes No N/A

11. All construction and equipment installation contracts exceeding \$3,000 contain or will contain a contract provision that discourages distracted driving (E.O. 13513).

Yes No N/A

12. All contracts exceeding \$10,000 contain or will contain the following provisions as applicable:

- a. Construction and equipment installation projects - Applicable clauses from 41 CFR Part 60 for compliance with Executive Orders 11246 and 11375 on Equal Employment Opportunity;
- b. Construction and equipment installation - Contract Clause prohibiting segregated facilities in accordance with 41 CFR part 60-1.8;
- c. Requirement to maximize use of products containing recovered materials in accordance with 2 CFR § 200.322 and 40 CFR part 247; and
- d. Provisions that address termination for cause and termination for convenience (2 CFR Part 200, Appendix II).

Yes No N/A

13. All contracts and subcontracts exceeding \$25,000: Measures are in place or will be in place (e.g. checking the System for Award Management) that ensure contracts and subcontracts are not awarded to individuals or firms suspended, debarred, or excluded from participating in federally assisted projects (2 CFR parts 180 and 1200).

Yes No N/A

14. Contracts exceeding the simplified acquisition threshold (currently \$250,000) include or will include provisions, as applicable, that address the following:

- a. Construction and equipment installation contracts - a bid guarantee of 5%, a performance bond of 100%, and a payment bond of 100% (2 CFR § 200.325);
- b. Construction and equipment installation contracts - requirements of the Contract Work Hours and Safety Standards Act (40 USC 3701-3708, Sections 103 and 107);
- c. Restrictions on Lobbying and Influencing (2 CFR part 200, Appendix II);
- d. Conditions specifying administrative, contractual and legal remedies for instances where contractor or vendor violate or breach the terms and conditions of the contract (2 CFR §200, Appendix II); and
- e. All Contracts - Applicable standards and requirements issued under Section 306 of the Clean Air Act (42 USC 7401-7671q), Section 508 of the Clean Water Act (33 USC 1251-1387, and Executive Order 11738.

Yes No N/A

Attach documentation clarifying any above item marked with "No" response.

Sponsor's Certification

I certify, for the project identified herein, responses to the forgoing items are accurate as marked and additional documentation for any item marked "no" is correct and complete.

Executed on this day of , .

Name of Sponsor:

Name of Sponsor's Authorized Official:

Title of Sponsor's Authorized Official:

Signature of Sponsor's Authorized Official: Philip F. Calderone

I declare under penalty of perjury that the foregoing is true and correct. I understand that knowingly and willfully providing false information to the federal government is a violation of 18 USC § 1001 (False Statements) and could subject me to fines, imprisonment, or both.



U.S. Department
of Transportation
**Federal Aviation
Administration**

FAA Form 5100-132, Project Plans and Specifications – Airport Improvement Program Sponsor Certification

Paperwork Reduction Act Statement

A federal agency may not conduct or sponsor, and a person is not required to respond to, nor shall a person be subject to a penalty for failure to comply with a collection of information subject to the requirements of the Paperwork Reduction Act unless that collection of information displays a currently valid OMB Control Number. The OMB Control Number for this information collection is 2120-0569. Public reporting for this collection of information is estimated to be approximately 8 hours per response, including the time for reviewing instructions, searching existing data sources, gathering and maintaining the data needed, completing and reviewing the collection of information. All responses to this collection of information are required under 49 U.S.C. Section 47105 to retain a benefit and to meet the reporting requirements of 2 CFR 200. Send comments regarding this burden estimate or any other aspect of this collection of information, including suggestions for reducing this burden to: Information Collection Clearance Officer, Federal Aviation Administration, 10101 Hillwood Parkway, Fort Worth, TX 76177-1524.

Project Plans and Specifications

Airport Improvement Program Sponsor Certification

Sponsor:

Airport:

Project Number:

Description of Work:

Application

49 USC § 47105(d) authorizes the Secretary to require certification from the sponsor that it will comply with the statutory and administrative requirements in carrying out a project under the Airport Improvement Program (AIP). Labor and civil rights standards applicable to AIP are established by the Department of Labor (www.dol.gov/). AIP Grant Assurance C.1—General Federal Requirements identifies applicable federal laws, regulations, executive orders, policies, guidelines and requirements for assistance under AIP. A list of current advisory circulars with specific standards for procurement, design or construction of airports, and installation of equipment and facilities is referenced in standard airport sponsor Grant Assurance 34 contained in the grant agreement.

Certification Statements

Except for certification statements below marked as not applicable (N/A), this list includes major requirements of the construction project. Selecting “Yes” represents sponsor acknowledgement and confirmation of the certification statement. The term “will” means Sponsor action taken at appropriate time based on the certification statement focus area, but no later than the end of the project period of performance. This list is not comprehensive and does not relieve the sponsor from fully complying with all applicable statutory and administrative standards. The source of the requirement is referenced within parenthesis.

1. The plans and specifications were or will be prepared in accordance with applicable federal standards and requirements, so that no deviation or modification to standards set forth in the advisory circulars, or FAA-accepted state standard, is necessary other than those explicitly approved by the Federal Aviation Administration (FAA) (14 USC § 47105).

Yes No N/A

2. Specifications incorporate or will incorporate a clear and accurate description of the technical requirement for the material or product that does not contain limiting or proprietary features that unduly restrict competition (2 CFR §200.319).

Yes No N/A

3. The development that is included or will be included in the plans is depicted on the current airport layout plan as approved by the FAA (14 USC § 47107).

Yes No N/A

4. Development and features that are ineligible or unallowable for AIP funding have been or will be omitted from the plans and specifications (FAA Order 5100.38, par. 3-43).

Yes No N/A

5. The specification does not use or will not use "brand name" or equal to convey requirements unless sponsor requests and receives approval from the FAA to use brand name (FAA Order 5100.38, Table U-5).

Yes No N/A

6. The specification does not impose or will not impose geographical preference in their procurement requirements (2 CFR §200.319(b) and FAA Order 5100.38, Table U-5).

Yes No N/A

7. The use of prequalified lists of individuals, firms or products include or will include sufficient qualified sources that ensure open and free competition and that does not preclude potential entities from qualifying during the solicitation period (2 CFR §319(d)).

Yes No N/A

8. Solicitations with bid alternates include or will include explicit information that establish a basis for award of contract that is free of arbitrary decisions by the sponsor (2 CFR § 200.319(a)(7)).

Yes No N/A

9. Concurrence was or will be obtained from the FAA if Sponsor incorporates a value engineering clause into the contract (FAA Order 5100.38, par. 3-57).

Yes No N/A

10. The plans and specifications incorporate or will incorporate applicable requirements and recommendations set forth in the federally approved environmental finding (49 USC §47106(c)).

Yes No N/A

11. The design of all buildings comply or will comply with the seismic design requirements of 49 CFR § 41.120. (FAA Order 5100.38d, par. 3-92)

Yes No N/A

12. The project specification include or will include process control and acceptance tests required for the project by as per the applicable standard:

a. Construction and installation as contained in Advisory Circular (AC) 150/5370-10.

Yes No N/A

b. Snow Removal Equipment as contained in AC 150/5220-20.

Yes No N/A

c. Aircraft Rescue and Fire Fighting (ARFF) vehicles as contained in AC 150/5220-10.

Yes No N/A

13. For construction activities within or near aircraft operational areas(AOA):

a. The Sponsor has or will prepare a construction safety and phasing plan (CSPP) conforming to Advisory Circular 150/5370-2.

b. Compliance with CSPP safety provisions has been or will be incorporated into the plans and specifications as a contractor requirement.

c. Sponsor will not initiate work until receiving FAA's concurrence with the CSPP (FAA Order 5100.38, Par. 5-29).

Yes No N/A

14. The project was or will be physically completed without federal participation in costs due to errors and omissions in the plans and specifications that were foreseeable at the time of project design (49 USC §47110(b)(1) and FAA Order 5100.38d, par. 3-100).

Yes No N/A

Attach documentation clarifying any above item marked with "No" response.

Sponsor's Certification

I certify, for the project identified herein, responses to the forgoing items are accurate as marked and additional documentation for any item marked "no" is correct and complete.

Executed on this day of , .

Name of Sponsor:

Name of Sponsor's Authorized Official:

Title of Sponsor's Authorized Official:

Signature of Sponsor's Authorized Official: Philip F. Calderone

I declare under penalty of perjury that the foregoing is true and correct. I understand that knowingly and willfully providing false information to the federal government is a violation of 18 USC § 1001 (False Statements) and could subject me to fines, imprisonment, or both.



U.S. Department
of Transportation
**Federal Aviation
Administration**

FAA Form 5100-134, Selection of Consultants – Airport Improvement Program Sponsor Certification

Paperwork Reduction Act Statement

A federal agency may not conduct or sponsor, and a person is not required to respond to, nor shall a person be subject to a penalty for failure to comply with a collection of information subject to the requirements of the Paperwork Reduction Act unless that collection of information displays a currently valid OMB Control Number. The OMB Control Number for this information collection is 2120-0569. Public reporting for this collection of information is estimated to be approximately 8 hours per response, including the time for reviewing instructions, searching existing data sources, gathering and maintaining the data needed, completing and reviewing the collection of information. All responses to this collection of information are required under 49 U.S.C. Section 47105 to retain a benefit and to meet the reporting requirements of 2 CFR 200. Send comments regarding this burden estimate or any other aspect of this collection of information, including suggestions for reducing this burden to: Information Collection Clearance Officer, Federal Aviation Administration, 10101 Hillwood Parkway, Fort Worth, TX 76177-1524.



Selection of Consultants Airport Improvement Program Sponsor Certification

Sponsor:

Airport:

Project Number:

Description of Work:

Application

49 USC § 47105(d) authorizes the Secretary to require certification from the sponsor that it will comply with the statutory and administrative requirements in carrying out a project under the Airport Improvement Program (AIP). General requirements for selection of consultant services within federal grant programs are described in 2 CFR §§ 200.317-200.326. Sponsors may use other qualifications-based procedures provided they are equivalent to standards of Title 40 chapter 11 and FAA Advisory Circular 150/5100-14, Architectural, Engineering, and Planning Consultant Services for Airport Grant Projects.

Certification Statements

Except for certification statements below marked as not applicable (N/A), this list includes major requirements of the construction project. Selecting “Yes” represents sponsor acknowledgement and confirmation of the certification statement. The term “will” means Sponsor action taken at appropriate time based on the certification statement focus area, but no later than the end of the project period of performance. This list is not comprehensive and does not relieve the sponsor from fully complying with all applicable statutory and administrative standards. The source of the requirement is referenced within parenthesis.

1. Sponsor acknowledges their responsibility for the settlement of all contractual and administrative issues arising out of their procurement actions (2 CFR § 200.318(k)).

Yes No N/A

2. Sponsor procurement actions ensure or will ensure full and open competition that does not unduly limit competition (2 CFR § 200.319).

Yes No N/A

3. Sponsor has excluded or will exclude any entity that develops or drafts specifications, requirements, or statements of work associated with the development of a request-for-qualifications (RFQ) from competing for the advertised services (2 CFR § 200.319).

Yes No N/A

4. The advertisement describes or will describe specific project statements-of-work that provide clear detail of required services without unduly restricting competition (2 CFR § 200.319).

Yes	No	N/A
-----	----	-----

5. Sponsor has publicized or will publicize a RFQ that:
 - a. Solicits an adequate number of qualified sources (2 CFR § 200.320(d)); and
 - b. Identifies all evaluation criteria and relative importance (2 CFR § 200.320(d)).

Yes	No	N/A
-----	----	-----

6. Sponsor has based or will base selection on qualifications, experience, and disadvantaged business enterprise participation with price not being a selection factor (2 CFR § 200.320(d)).

Yes	No	N/A
-----	----	-----

7. Sponsor has verified or will verify that agreements exceeding \$25,000 are not awarded to individuals or firms suspended, debarred or otherwise excluded from participating in federally assisted projects (2 CFR §180.300).

Yes	No	N/A
-----	----	-----

8. A/E services covering multiple projects: Sponsor has agreed to or will agree to:
 - a. Refrain from initiating work covered by this procurement beyond five years from the date of selection (AC 150/5100-14); and
 - b. Retain the right to conduct new procurement actions for projects identified or not identified in the RFQ (AC 150/5100-14).

Yes	No	N/A
-----	----	-----

9. Sponsor has negotiated or will negotiate a fair and reasonable fee with the firm they select as most qualified for the services identified in the RFQ (2 CFR § 200.323).

Yes	No	N/A
-----	----	-----

10. The Sponsor's contract identifies or will identify costs associated with ineligible work separately from costs associated with eligible work (2 CFR § 200.302).

Yes	No	N/A
-----	----	-----

11. Sponsor has prepared or will prepare a record of negotiations detailing the history of the procurement action, rationale for contract type and basis for contract fees (2 CFR §200.318(i)).

Yes	No	N/A
-----	----	-----

12. Sponsor has incorporated or will incorporate mandatory contact provisions in the consultant contract for AIP-assisted work (49 U.S.C. Chapter 471 and 2 CFR part 200 Appendix II)

Yes	No	N/A
-----	----	-----

13. For contracts that apply a time-and-material payment provision (also known as hourly rates, specific rates of compensation, and labor rates), the Sponsor has established or will establish:

- a. Justification that there is no other suitable contract method for the services (2 CFR §200.318(j));
- b. A ceiling price that the consultant exceeds at their risk (2 CFR §200.318(j)); and
- c. A high degree of oversight that assures consultant is performing work in an efficient manner with effective cost controls in place 2 CFR §200.318(j)).

Yes No N/A

14. Sponsor is not using or will not use the prohibited cost-plus-percentage-of-cost (CPPC) contract method. (2 CFR § 200.323(d)).

Yes No N/A

Attach documentation clarifying any above item marked with "no" response.

Sponsor's Certification

I certify, for the project identified herein, responses to the forgoing items are accurate as marked and additional documentation for any item marked "no" is correct and complete.

I declare under penalty of perjury that the foregoing is true and correct. I understand that knowingly and willfully providing false information to the federal government is a violation of 18 USC § 1001 (False Statements) and could subject me to fines, imprisonment, or both.

Executed on this day of , .

Name of Sponsor:

Name of Sponsor's Authorized Official:

Title of Sponsor's Authorized Official:

Signature of Sponsor's Authorized Official: Philip F. Calderone

I declare under penalty of perjury that the foregoing is true and correct. I understand that knowingly and willfully providing false information to the federal government is a violation of 18 USC § 1001 (False Statements) and could subject me to fines, imprisonment, or both.



U.S. Department
of Transportation
**Federal Aviation
Administration**

FAA Form 5100-135, Certification and Disclosure Regarding Potential Conflicts of Interest – Airport Improvement Program Sponsor Certification

Paperwork Reduction Act Statement

A federal agency may not conduct or sponsor, and a person is not required to respond to, nor shall a person be subject to a penalty for failure to comply with a collection of information subject to the requirements of the Paperwork Reduction Act unless that collection of information displays a currently valid OMB Control Number. The OMB Control Number for this information collection is 2120-0569. Public reporting for this collection of information is estimated to be approximately 8 hours per response, including the time for reviewing instructions, searching existing data sources, gathering and maintaining the data needed, completing and reviewing the collection of information. All responses to this collection of information are required under 49 U.S.C. Section 47105 to retain a benefit and to meet the reporting requirements of 2 CFR 200. Send comments regarding this burden estimate or any other aspect of this collection of information, including suggestions for reducing this burden to: Information Collection Clearance Officer, Federal Aviation Administration, 10101 Hillwood Parkway, Fort Worth, TX 76177-1524.



Certification and Disclosure Regarding Potential Conflicts of Interest Airport Improvement Program Sponsor Certification

Sponsor:

Airport:

Project Number:

Description of Work:

Application

Title 2 CFR § 200.112 and § 1201.112 address Federal Aviation Administration (FAA) requirements for conflict of interest. As a condition of eligibility under the Airport Improvement Program (AIP), sponsors must comply with FAA policy on conflict of interest. Such a conflict would arise when any of the following have a financial or other interest in the firm selected for award:

- a) The employee, officer or agent,
- b) Any member of his immediate family,
- c) His or her partner, or
- d) An organization which employs, or is about to employ, any of the above.

Selecting "Yes" represents sponsor or sub-recipient acknowledgement and confirmation of the certification statement. Selecting "No" represents sponsor or sub-recipient disclosure that it cannot fully comply with the certification statement. If "No" is selected, provide support information explaining the negative response as an attachment to this form. This includes whether the sponsor has established standards for financial interest that are not substantial or unsolicited gifts are of nominal value (2 CFR § 200.318(c)). The term "will" means Sponsor action taken at appropriate time based on the certification statement focus area, but no later than the end of the project period of performance.

Certification Statements

1. The sponsor or sub-recipient maintains a written standards of conduct governing conflict of interest and the performance of their employees engaged in the award and administration of contracts (2 CFR § 200.318(c)). To the extent permitted by state or local law or regulations, such standards of conduct provide for penalties, sanctions, or other disciplinary actions for violations of such standards by the sponsor's and sub-recipient's officers, employees, or agents, or by contractors or their agents.

Yes No

2. The sponsor's or sub-recipient's officers, employees or agents have not and will not solicit or accept gratuities, favors or anything of monetary value from contractors, potential contractors, or parties to sub-agreements (2 CFR § 200.318(c)).

Yes No

3. The sponsor or sub-recipient certifies that is has disclosed and will disclose to the FAA any known potential conflict of interest (2 CFR § 1200.112).

Yes No

Attach documentation clarifying any above item marked with "no" response.

Sponsor's Certification

I certify, for the project identified herein, responses to the forgoing items are accurate as marked and have the explanation for any item marked "no" is correct and complete.

Executed on this day of , .

Name of Sponsor:

Name of Sponsor's Authorized Official:

Title of Sponsor's Authorized Official:

Signature of Sponsor's Authorized Official: *Philip F. Calderone*

I declare under penalty of perjury that the foregoing is true and correct. I understand that knowingly and willfully providing false information to the federal government is a violation of 18 USC § 1001 (False Statements) and could subject me to fines, imprisonment, or both.



U.S. Department
of Transportation
**Federal Aviation
Administration**

FAA Form 5100-145, FAA Title VI Pre-Grant Award Checklist

Paperwork Reduction Act Statement

A federal agency may not conduct or sponsor, and a person is not required to respond to, nor shall a person be subject to a penalty for failure to comply with a collection of information subject to the requirements of the Paperwork Reduction Act unless that collection of information displays a currently valid OMB Control Number. The OMB Control Number for this information collection is 2120-0569. Public reporting for this collection of information is estimated to be approximately 8 hours per response, including the time for reviewing instructions, searching existing data sources, gathering, and maintaining the data needed, completing and reviewing the collection of information.

All responses to this collection of information are required under 49 U.S.C. Section 47105 to retain a benefit and to meet the reporting requirements of 2 CFR 200. Send comments regarding this burden estimate or any other aspect of this collection of information, including suggestions for reducing this burden to: Information Collection Clearance Officer, Federal Aviation Administration, 10101 Hillwood Parkway, Fort Worth, TX 76177-1524

Instructions for Form 5100-145, FAA Title VI Pre-Grant Award Checklist

This Checklist must be completed and submitted by the sponsor as a part of each FAA grant application.

"Yes" responses mean that the sponsor is currently in compliance or has a corrective action plan approved by the FAA Office of Civil Rights (FAA) to come into compliance. "No" responses mean there is a potential compliance issue. Compliance issues will be brought to the attention of the FAA to determine if corrective actions are necessary. If there are any questions, please contact ACR-4-TitleVI@faa.gov.

References to "Title VI" in this checklist include Title VI of the Civil Rights Act of 1964 and related authorities that expand or clarify nondiscrimination protections in FAA assisted programs, identified in [FAA Order 1400.11](https://www.faa.gov/regulations_policies/orders_notices/index.cfm/go/document.current/documentNumber/1400.11) [https://www.faa.gov/regulations_policies/orders_notices/index.cfm/go/document.current/documentNumber/1400.11].

FAA Title VI Pre-Grant Award Checklist

Submission information

Submission date (Pick a date):

Name of airport sponsor:

Submitter's name:

Title:

Phone number:

Section 1: Questions Concerning Prior Approval of Title VI Program

By selecting "Yes" below, the sponsor certifies that the following documents were provided to, and approved by, the FAA Office of Civil Rights, and documentation of FAA's approval has been received by the sponsor. The FAA Office reviewing this grant application will confirm the FAA's approval of the documents in this Section prior to approving the grant application.

A sponsor that has **both** a Title VI* Plan and a Community Participation Plan, **both** of which are approved by the FAA and current, and has already received approval for the information outlined in this Checklist, does not need to complete the remaining questions in Sections 2 and 3 of this Checklist.

This information is required based on [DOT Order 1000.12C, Ch. II, Secs. 3 and 4](https://www.transportation.gov/mission/us-department-transportation-title-vi-program)
[https://www.transportation.gov/mission/us-department-transportation-title-vi-program].

Criterion	Notes	Response	Comments
<p>1.1 The sponsor has a written Title VI Plan, approved by the FAA Office of Civil Rights, and subsequently adopted by the recipient, and documentation of the approval and adoption.</p>	<p>Sponsors must develop and adopt a Title VI Plan that outlines the recipient’s measures to ensure compliance with Title VI. A current Title VI Plan on file with the FAA is sufficient if the Plan is no more than 3 years old.</p> <p>If the sponsor does not have an approved Title VI Plan, select "No" and complete Sections 2 and 3 of this Checklist.</p>	<p>Yes No</p>	
<p>1.2 The sponsor has a written Community Participation Plan (CPP), or an equivalent public participation plan (PPP), and documented approval or concurrence of the plan from the FAA Office of Civil Rights.</p>	<p>Sponsors must satisfy CPP requirements as a condition of receiving an award of federal financial assistance. To the extent the sponsor has already prepared a PPP as part of planning or other requirements of FAA or DOT, that plan or plans may satisfy the CPP requirement so long as the plan has incorporated the Title VI requirements as provided in DOT Order 1000.12C, Ch. II, Sec. 4(a-j).</p> <p>If the sponsor does not have an approved CPP or PPP, select "No" and answer question 3.5 in Section 3 of this Checklist.</p>	<p>Yes No</p>	

If the answers to 1.1 and 1.2 above are both “Yes,” do *not* complete Sections 2 and 3.

Section 2: Questions Concerning Applicant Data

By selecting "Yes" below, the sponsor certifies that the following documents have been collected in its records prior to submitting this grant application and will be timely made available to FAA staff, including from the FAA Offices of Airports, Chief Counsel, and Civil Rights, upon request.

"Timely available" usually means within 1 week or less, depending on the scope and circumstances. The data should already be available in a format that can be forwarded, as-is. No further data collection or summarization efforts should be necessary to respond to the request.

This information is required by DOT Order 1000.12C, Ch. II, Sec. 2; 49 CFR 21.9; and FAA Order 1400.11.

Criterion	Notes	Response	Comments
<p>2.1 The sponsor has, on file, demographic information for the surrounding community and communities otherwise affected by the sponsor's facilities and operations, including any airport noise and relocations.</p>	<p>At a minimum, data is required for race, color, national origin, and limited English proficiency (LEP) populations. The collected data must include the most current U.S. Census Bureau data, where available, such as American Community Survey data.</p> <p>EJScreen [www.epa.gov/ejscreen] is a useful resource for assessing project areas.</p>	<p>Yes</p> <p>No</p>	
<p>2.2 The sponsor has, on file, demographic information for beneficiaries. For example, if the applicant is an airport operator, it has collected information for its airport customers.</p>	<p>In most cases, this type of information is available through voluntary disclosures by customers, lessees, community meeting attendees, and businesses seeking opportunities with the applicant.</p> <p>If not applicable or after reasonable efforts, no information was collected, respond, "Yes."</p>	<p>Yes</p> <p>No</p>	

Criterion	Notes	Response	Comments
<p>2.3 The sponsor has, on file, demographic information for their staff.</p>	<p>In most cases, this type of information is available through voluntary disclosures. See also 49 CFR § 21.5(c).</p> <p>If not applicable or after reasonable efforts, no information was collected, respond, "Yes."</p>	<p>Yes No</p>	
<p>2.4 The sponsor has, on file, demographic information for individuals who are members of planning or advisory boards overseeing the applicant's programs, including its airport operations (if applicable).</p>	<p>Airport sponsors, the most common FAA grant applicants, commonly have appointed boards or are overseen directly by elected bodies, such as city councils. In addition, input for specific projects or sponsor priorities is often provided by standing appointed committees. If not already available, the information can be requested on a voluntary basis.</p> <p>If not applicable or after reasonable efforts, no information was collected, respond, "Yes."</p>	<p>Yes No</p>	

Section 3: Questions about the Sponsor's Programs

By choosing "Yes" below, the sponsor certifies that the related statements are true.

This information is required by DOT Order 1000.12C, Ch. II, Secs. 2, 3, and 4.

Criterion	Notes	Response	Comments
<p>3.1 The sponsor's programs, including any airport operations, have been evaluated for potential impact based on race, color, national origin (including limited English proficiency (LEP)), or low-income status as part of an environmental review process consistent with FAA requirements.</p>	<p>Relevant requirements include Title VI of the Civil Rights Act of 1964 (42 U.S.C. 2000d, et seq.) ("Title VI"), DOT's Title VI regulations at 49 CFR part 21, Executive Order 12898, and DOT Order on Environmental Justice (Order 5610.2C).</p> <p>See Title VI of the Civil Rights Act of 1964 [www.justice.gov/crt/fcs/TitleVI];</p> <p>49 CFR part 21 [www.ecfr.gov]</p> <p>DOT Order on Environmental Justice [www.transportation.gov/transportation-policy/environmental-justice]</p>	<p>Yes</p> <p>No</p>	
<p>3.2 The sponsor has evaluated Checklist Section 2 data to identify any potential disparities based on race, color, or national origin (including LEP), as part of an analysis to identify potential discriminatory effects, consistent with FAA requirements.</p>	<p>Relevant requirements include Title VI of the Civil Rights Act of 1964 (42 U.S.C. 2000d, et seq.) ("Title VI"), DOT's Title VI regulations at 49 CFR part 21, Executive Order 12898, and DOT Order on Environmental Justice (Order 5610.2C).</p>	<p>Yes</p> <p>No</p>	

Criterion	Notes	Response	Comments
<p>3.3 The sponsor has performed a “Four-Factor” LEP analysis for the sponsor’s programs, including its airport operations (if applicable). Plans and procedures and resources are in place to meet the identified LEP needs, consistent with the analysis.</p>	<p>A “Yes” response means yes to both parts of the question. The LEP analysis must be consistent with Executive Order 13166 and DOT Policy Guidance Concerning Recipients’ Responsibilities to LEP Persons (70 FR 74087, December 14, 2005).</p> <p>See DOT’s LEP Guidance [https://www.transportation.gov/civil-rights/civil-rights-awareness-enforcement/dots-lep-guidance].</p>	<p>Yes No</p>	
<p>3.4 If the sponsor is an airport sponsor, the FAA Unlawful Discrimination Poster is displayed at its public airport facilities.</p> <p>If the sponsor is <i>not</i> an airport sponsor, it uses other effective methods to inform its customers, clients, beneficiaries, etc., that it will not discriminate based on race, color, national origin (including LEP), age, sex (including sexual orientation and gender identity), or creed, and of how to file a complaint of discrimination under Title VI against the applicant.</p>	<p>For airport sponsors, areas where the posters should be displayed include, as applicable, airport terminals, fixed base operator facilities, and at businesses that are open to the public and operating on airport property, such as hotels. For larger facilities, posters should be placed so that people can reasonably be expected to see them, no matter where they are in the facility. The poster is available at Airport Civil Rights Program – National Airport Policy and Compliance [https://www.faa.gov/about/office_org/headquarters_offices/acr/com_civ_support/national_airport_policy_compliance/].</p> <p>If applicant is not an airport, the method used to inform the public must be ongoing and documented.</p>	<p>Yes No</p>	

Criterion	Notes	Response	Comments
<p>3.5 The sponsor's practices for obtaining proactive and meaningful public participation to ensure that (1) beneficiaries, as well as contractors and sub-recipients (if applicable), are adequately informed about how programs, projects, and other activities will potentially affect them, and</p> <p>(2) diverse views are heard and considered throughout all stages of consultation, planning, and decision-making processes.</p>	<p>To demonstrate compliance with Title VI, the sponsor must specifically be able to show how it affords all members of the community equal opportunity to provide input, regardless of race, color, national origin (including LEP), sex (including sexual orientation and gender identity), creed, or age, in accordance with Title VI, 49 U.S.C. § 47123, Executive Orders 12898 and 13166, DOT Order 5610.2C, and the DOT LEP guidance at 70 FR 74087.</p> <p>Please skip this question if the sponsor has an FAA-approved community participation plan.</p>	<p>Yes</p> <p>No</p>	
<p>3.6 Detailed information for all of the sponsor's Title VI lawsuits, investigations, and complaints filed or pending within the last 2 years been uploaded to the FAA Civil Rights Connect System or sent to ACR-4-TitleVI@faa.gov, with receipt acknowledged.</p>	<p>Sponsors must provide the FAA with both the initial notifications for the individual lawsuits, investigation, and complaints, and status updates. The updates are required until at least the time of grant closeout. The updates must include at least the outcome of the lawsuits, investigation, and complaint, and confirmation for resolution of identified deficiencies.</p> <p>See Appendix C to 49 CFR 21, Sub-part (b)(3) [available through www.ecfr.gov].</p> <p>"Title VI lawsuits, investigations, and complaints" include those alleging discrimination based on race, color, national origin (including LEP), sex (including sexual orientation and gender identity), creed or age.</p>	<p>Yes</p> <p>No</p>	

Criterion	Notes	Response	Comments
<p>3.7 Detailed information for all Title VI oversight activities (including audits, compliance reviews, and assessments for the sponsor) performed or pending within the last 2 years, has been sent to ACR-4-TitleVI@faa.gov, with receipt acknowledged. This requirement does not apply to oversight activities conducted by FAA.</p>	<p>Sponsors must provide the FAA with both the initial notifications for the individual audits, compliance reviews, and assessment, and status updates. The updates are required until at least the time of grant closeout. The updates must include at least the outcome of the audits, compliance reviews, and assessment, and confirmation for resolution of identified deficiencies.</p> <p>See Appendix C to 49 CFR 21, Sub-part (b)(3) [available through www.ecfr.gov].</p>	<p>Yes</p> <p>No</p>	
<p>3.8 Detailed information for any pending grant applications with Federal agencies other than FAA identified in the grant application.</p>	<p>The information should be included in narrative fields of the pending application.</p>	<p>Yes</p> <p>No</p>	

CERTIFICATION REGARDING LOBBYING

Certification for Contracts, Grants, Loans, and Cooperative Agreements

The undersigned certifies, to the best of his or her knowledge and belief, that:

(1) No Federal appropriated funds have been paid or will be paid, by or on behalf of the undersigned, to any person for influencing or attempting to influence an officer or employee of an agency, a Member of Congress, an officer or employee of Congress, or an employee of a Member of Congress in connection with the awarding of any Federal contract, the making of any Federal grant, the making of any Federal loan, the entering into of any cooperative agreement, and the extension, continuation, renewal, amendment, or modification of any Federal contract, grant, loan, or cooperative agreement.

(2) If any funds other than Federal appropriated funds have been paid or will be paid to any person for influencing or attempting to influence an officer or employee of any agency, a Member of Congress, an officer or employee of Congress, or an employee of a Member of Congress in connection with this Federal contract, grant, loan, or cooperative agreement, the undersigned shall complete and submit Standard Form-LLL, "Disclosure of Lobbying Activities," in accordance with its instructions.

(3) The undersigned shall require that the language of this certification be included in the award documents for all subawards at all tiers (including subcontracts, subgrants, and contracts under grants, loans, and cooperative agreements) and that all subrecipients shall certify and disclose accordingly. This certification is a material representation of fact upon which reliance was placed when this transaction was made or entered into. Submission of this certification is a prerequisite for making or entering into this transaction imposed by section 1352, title 31, U.S. Code. Any person who fails to file the required certification shall be subject to a civil penalty of not less than \$10,000 and not more than \$100,000 for each such failure.

Statement for Loan Guarantees and Loan Insurance

The undersigned states, to the best of his or her knowledge and belief, that:

If any funds have been paid or will be paid to any person for influencing or attempting to influence an officer or employee of any agency, a Member of Congress, an officer or employee of Congress, or an employee of a Member of Congress in connection with this commitment providing for the United States to insure or guarantee a loan, the undersigned shall complete and submit Standard Form-LLL, "Disclosure of Lobbying Activities," in accordance with its instructions. Submission of this statement is a prerequisite for making or entering into this transaction imposed by section 1352, title 31, U.S. Code. Any person who fails to file the required statement shall be subject to a civil penalty of not less than \$10,000 and not more than \$100,000 for each such failure.

* APPLICANT'S ORGANIZATION

Albany County Airport Authority-Albany International Airport

* PRINTED NAME AND TITLE OF AUTHORIZED REPRESENTATIVE

Prefix: * First Name: Philip Middle Name: F.

* Last Name: Calderone Suffix: Esq.

* Title: Chief Executive Officer

* SIGNATURE: *Philip F. Calderone*

* DATE: 06/28/2024

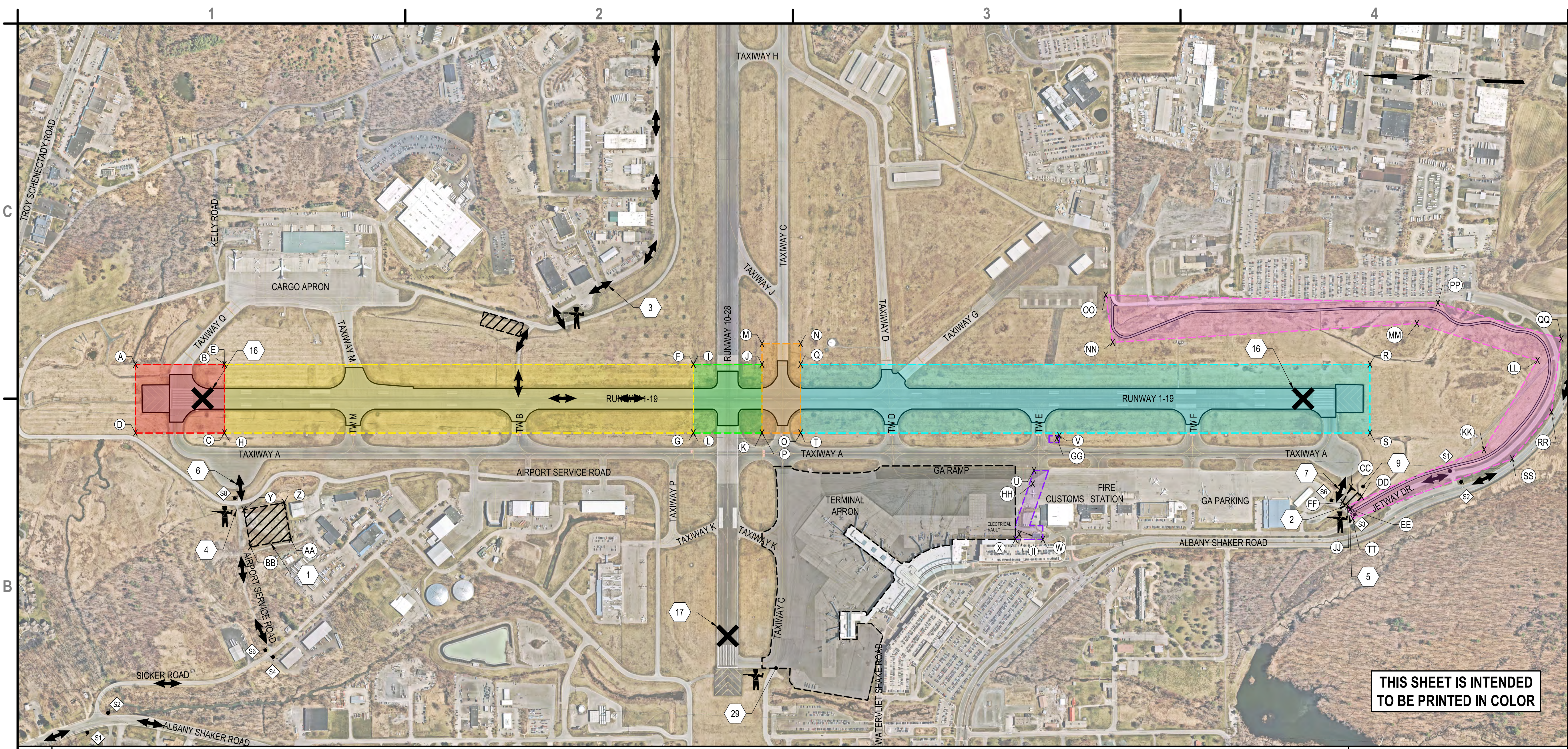

THIS SHEET IS INTENDED TO BE PRINTED IN COLOR

B1 OVERALL CONSTRUCTION SAFETY AND PHASING PLAN
SCALE: 1" = 400'

- PHASING NOTES:**
- UNLESS OTHERWISE NOTED, THE CONSTRUCTION WORK PERIOD FOR WORK AREAS A, B, D, E, F, G IS LIMITED TO THE HOURS BETWEEN 10:00PM AND 5:00AM ONLY. ALL CONSTRUCTION ACTIVITIES MUST BE COMPLETED EACH WORK PERIOD ALLOWING BOTH RUNWAYS AND ALL TAXIWAYS TO BE OPEN FOR AIRPORT OPERATIONS AT THE SCHEDULED TIME OF COMPLETION. THE CONTRACTOR MUST COORDINATE ALL OF THEIR ACTIVITIES AND ALSO ANY OF THEIR SUBCONTRACTOR'S ACTIVITIES SUCH THAT THIS DEADLINE WILL BE MET. IN ORDER TO COMPLY WITH THIS REQUIREMENT ALL PAVEMENT SURFACES MUST BE ABLE TO HANDLE AIRCRAFT LOADINGS. TEMPORARY MARKINGS MUST BE PLACED, ALL PAVEMENT SURFACES MUST BE COMPLETELY SWEEP AND FREE FROM DEBRIS. ALL ELECTRICAL SYSTEMS MUST BE OPERATIONAL, WITH THE EXCEPTION OF THE RUNWAY CENTERLINE LIGHTING, AND ALL APPROPRIATE BARRICADES MUST BE REMOVED. THIS WORK SHALL BE PAID FOR UNDER ITEM C-106, WORKING HOURS FOR WORK AREA C ARE FURTHER LIMITED. SEE SHEET GC103.
 - AT THE COMPLETION OF WORK IN ANY CONSTRUCTION PERIOD AND THIRTY (30) MINUTES PRIOR TO THE SCHEDULED OPENING OF THE DESIGNATED AIRFIELD FACILITIES, AN INSPECTION TO DETERMINE WHETHER THE RESPECTIVE AIRPORT FACILITIES ARE IN THE APPROPRIATE CONDITION TO BE OPENED SHALL BE PERFORMED BY AIRPORT OPERATIONS. THE CONTRACTOR'S CONSTRUCTION SUPERVISOR MUST BE PRESENT DURING THIS INSPECTION. THE CONTRACTOR SHALL HAVE STAFF AND EQUIPMENT AVAILABLE TO QUICKLY CORRECT ANY DEFICIENCIES PRIOR TO THE DESIGNATED OPENING TIME.
 - A MINIMUM OF 2 HOURS PRIOR TO EVERY WORK SHIFT, THE CONTRACTOR SHALL CALL AIRPORT OPERATIONS (518-242-2300) DAILY, TO CONFIRM WORK/SCHEDULE FOR THAT SHIFT.
 - AT THE END OF EACH WORK SHIFT, THE CONTRACTOR SHALL CALL AIRPORT OPERATIONS TO COORDINATE THE NEXT DAYS WORK SCHEDULE AND ACTIVITIES.
 - WITH A MINIMUM OF TWO HOURS ADVANCE NOTICE, THE START OF A SCHEDULED WORK PERIOD MAY BE POSTPONED OR CANCELED BY THE OWNER IF IT IS DETERMINED TO BE IN THE BEST INTEREST OF AIRPORT OPERATIONS OR SAFETY. IF NECESSARY, EXTENSIONS IN CONTRACT TIME MAY BE GRANTED OR A STOP WORK ORDER MAY BE ISSUED DUE TO THESE DELAYS.
 - CONTRACTOR MAY WORK IN MORE THAN ONE AREA PER NIGHT SEE CONCURRENT WORK AREA TABLE THIS SHEET.
 - FAILURE TO COMPLETE THE WORK ASSOCIATED WITH ANY OF THESE PHASES AND RETURN THE RUNWAY(S) TO FULL SERVICE AT THE DESIGNATED TIME EACH DAY, WILL RESULT IN THE ASSESSMENT OF LIQUIDATED DAMAGE IN THE AMOUNT OF \$5,000.00 PER A FIFTEEN MINUTE PERIOD OR PORTION THEREOF, BEYOND 5:00AM. THESE DAMAGES ARE CONSIDERED SEPARATE FROM THOSE DESIGNATED FOR THE COMPLETION OF THE TOTAL PROJECT AND SHALL BE DEDUCTED FROM ALL FUTURE PAYMENT REQUESTS MADE BY THE CONTRACTOR.
 - BACK-UP EQUIPMENT, THE CONTRACTOR SHALL BE REQUIRED TO SUBMIT A PLAN FOR THE IMMEDIATE REPLACEMENT OF CRITICAL EQUIPMENT PIECES DUE TO THE MECHANICAL FAILURE OR SUBSTANDARD PERFORMANCE. THE PLAN SHALL IDENTIFY THE TYPE OF EQUIPMENT, THE STAGING LOCATION OF SAID EQUIPMENT, AND THE STEPS REQUIRED TO DELIVER AND PLACE THE EQUIPMENT INTO SERVICE. AT A MINIMUM THE PLAN SHALL IDENTIFY KEY PIECES OF BACK-UP EQUIPMENT INCLUDING BUT NOT LIMITED TO MILLING MACHINES, PAVERS, PAVING PLANTS, AND ROLLERS. THE PLANS MUST BE IN PLACE AND APPROVED BY THE OWNER AND ENGINEER PRIOR TO THE START OF CONSTRUCTION.
 - TOUCHDOWN ZONE LIGHTING HOME RUNS SHALL BE INSTALLED DURING WORK IN WORK AREA E WHEN WORKING IN RSA. WHEN WORKING OUTSIDE RSA AND THE TAXIWAY A OBJECT FREE AREA, HOME RUNS SHALL BE INSTALLED IN TURF AREAS AND INSTALLED IN EXISTING CONDUIT IN PAVED AREAS, AS APPROVED BY THE ENGINEER AND OWNER. THE CONTRACTOR WILL BE REQUIRED TO YIELD TO ALL AIRCRAFT.
 - ALL WORK DISPLAYED ON SHEETS GC100 - GC107 AND GC501 THAT IS NOT LISTED UNDER A SEPARATE ITEM NUMBER SHALL BE PAID UNDER ITEM C-106 SAFETY, SECURITY AND MAINTENANCE OF TRAFFIC.
 - FIVE (5) TEMPORARY LIGHTED CLOSED RUNWAY MARKINGS SHALL BE PROVIDED BY THE OWNER. TEMPORARY LIGHTED CLOSED RUNWAY MARKINGS SHALL BE INSTALLED BY THE CONTRACTOR PRIOR TO ANY WORK WITHIN RUNWAY 1-19 AND RUNWAY 10-28 SAFETY AREAS. ALL CLOSED RUNWAY MARKINGS SHALL BE REMOVED BY THE CONTRACTOR PRIOR TO OPENING RUNWAY. THE CONTRACTOR SHALL BE RESPONSIBLE TO TRANSPORT, SETUP, RELOCATE, MAINTAIN, FUEL, AND REMOVE ALL LIGHTED CLOSED RUNWAY MARKINGS.
 - LIGHTING ON ACTIVE APRON AREAS, TAXIWAY AND RUNWAYS SHALL BE OPERATIONAL AT THE CLOSE OF EACH NIGHTLY WORK SHIFT, EXCEPT THE RUNWAY 1-19 CENTERLINE LIGHTS, WHICH SHALL BE DEACTIVATED / DISCONNECTED FOR LONGER PERIODS OF TIME.
 - THE CONTRACTOR SHALL COORDINATE AND BE RESPONSIBLE FOR THE TESTING OF THE RUNWAY, TAXIWAYS AND APRON LIGHTING SYSTEM, AND INSTRUCTION OF THE AIRPORT MANAGEMENT AS TO ITS OPERATION.

SEQUENCE OF OPERATIONS (ON RW 1-19)	ACTIVE WORK AREA	CONCURRENT WORK AREAS ALLOWED	NOTES
1	D	A OR B, F, G	SEQUENCE OF OPERATIONS PREVENTS CONCURRENT WORK IN WORK AREAS C, D, AND E
2	E	A OR B, F, G	SEQUENCE OF OPERATIONS PREVENTS CONCURRENT WORK IN WORK AREAS C, D, AND E
3	C	A, B, D, E, F, G	AIRCRAFT PAVEMENTS CLOSED TO AIRCRAFT, ALL WORK AREAS MAY RUN CONCURRENT WHILE WORK TAKES PLACE IN WORK AREA C
4	B	F, G	
5	A	F, G	
	F		DAYTIME WORK ONLY UNDER VFR CONDITIONS. COORDINATE WITH OWNER
	G	A, B, C, D, E, F	WORK AREA G MAY RUN CONCURRENT TO ALL OTHER WORK AREAS

- PHASES:** (REFER TO SPECIFICATION, SECTION C-001 FOR ADDITIONAL INFORMATION)
- PHASE 1 - PRE-CONSTRUCTION - THE OWNER WILL ISSUE AN ADMINISTRATIVE NOTICE TO PROCEED (NTP) AFTER CONTRACT AWARD AND EXECUTION. THE ADMINISTRATIVE NTP WILL AUTHORIZE ORDERING OF LONG LEAD-TIME ELECTRICAL MATERIALS, COMPLETION OF ELECTRICAL FIELD INVESTIGATIONS, AND COMPLETION OF SURVEY AND STAKEOUT. ALL FIELD INVESTIGATIONS AND SURVEY WILL BE PERFORMED AT NIGHT BETWEEN THE HOURS OF 10:00PM AND 5:00AM. CONTRACTOR WILL BE REQUIRED TO PLACE LIGHTED RUNWAY CLOSURE MARKINGS AND ALL BARRICADES.
- PHASE 2 - COMPLETE PAVEMENT REHABILITATION, TEMPORARY MARKING, LIGHTING AND ELECTRICAL WORK IN WORK AREAS A-F, WITH THE EXCEPTION OF NEW RUNWAY CENTERLINE LIGHT FIXTURES. PHASE 2 MAY INCLUDE THE SOUTH SIDE SERVICE ROAD REHABILITATION.
- PHASE 3 - COMPLETE GROOVING IN WORK AREAS A-E AFTER P-621 SPECIFICATION CURE PERIOD. PHASE 3 MAY INCLUDE THE SOUTH SIDE SERVICE ROAD REHABILITATION.
- PHASE 4 - COMPLETE PERMANENT PAVEMENT MARKINGS, RUNWAY EDGE LIGHT FIXTURES, AND RUNWAY CENTERLINE LIGHT FIXTURES IN WORK AREAS A-F. PHASE 4 MAY BEGIN PRIOR TO PHASE 3 COMPLETION ONCE GROOVING OPERATIONS ALLOW PERMANENT MARKING TO BE APPLIED. PHASE 4 MAY INCLUDE THE SOUTH SIDE SERVICE ROAD REHABILITATION. COMPLETION OF PHASE 4 ACHIEVES SUBSTANTIAL COMPLETION.
- PHASE 5 - POST-CONSTRUCTION - COMPLETE CONTRACT CLOSEOUT AND FINAL ACCEPTANCE.
- WORK AREAS:**
- WORK AREA A - WORK AREA INCLUDES THE RUNWAY 19 END UP TO THE NORTHERN TOFA LIMIT OF TAXIWAY M (APPROXIMATE STA. 100+45 TO 106+95).
- WORK AREA B - WORK AREA INCLUDES THE AREA FROM THE NORTHERN TOFA LIMIT OF TAXIWAY M TO THE NORTHERN RSA LIMIT OF RUNWAY 10-28 (APPROXIMATE STA. 106+95 TO 141+10).
- WORK AREA C - WORK AREA INCLUDES THE INTERSECTION OF RUNWAY 1-19 AND 10-28 INSIDE THE RSA OF THE RUNWAY 10-28 (500' WIDTH, APPROXIMATE STA. 141+10 TO 146+10).
- WORK AREA D - WORK AREA INCLUDES THE AREA FROM THE SOUTHERN RSA LIMITS OF RUNWAY 10-28 TO THE SOUTHERN TOFA LIMIT OF TAXIWAY C (APPROXIMATE STA. 146+10 TO 148+95).
- WORK AREA E - WORK AREA INCLUDES THE RUNWAY 01 END TO THE SOUTHERN TOFA LIMIT OF TAXIWAY C (APPROXIMATE STA. 148+95 TO 190+45).
- WORK AREA F - WORK AREA INCLUDES THE AREA FROM THE RUNWAY 01-19 RSA TO THE ELECTRICAL VAULT. FOLLOWING THE AIRFIELD ELECTRICAL HOMERUN DUCT BANK ROUTE.
- WORK AREA G - WORK AREA INCLUDES THE AREA OF SERVICE ROAD ALONG THE PERIMETER FENCE PAST THE SOUTHER END OF RUNWAY 1-19.

	WORK AREA "A" LIMITS		WORK AREA "D" LIMITS
	WORK AREA "B" LIMITS		WORK AREA "E" LIMITS
	WORK AREA "C" LIMITS		WORK AREA "F" LIMITS
	CONTRACTOR'S STAGING AREA		WORK AREA "G" LIMITS
	SIDA AREA		CLOSED RUNWAY MARKING
	GATE GUARD LOCATION		CONSTRUCTION HAUL ROUTE
	CONSTRUCTION ACCESS SIGN		WORK AREA COORDINATE, SEE C1/GC501

- NORTH CONTRACTOR'S STAGING AREA
- SOUTH CONTRACTOR'S STAGING AREA
- CONTRACTOR'S ACCESS TO WORK AREAS "B" & "C"
- CONTRACTOR'S ACCESS THROUGH EXISTING GATE 15A
- CONTRACTOR'S ACCESS THROUGH EXISTING GATE 6
- CONTRACTOR'S ACCESS TO WORK AREA "A"
- CONTRACTOR'S ACCESS TO WORK AREAS "D", "E", "F" & "G"
- TEMPORARY CONSTRUCTION ACCESS SIGN, ITEM C-106 (TYP.), SEE DETAIL A2/GC501.
- ENGINEER'S FIELD OFFICE, FINAL LOCATION TO BE DETERMINED BY OWNER
- TEMPORARY LIGHTED CLOSED RUNWAY MARKING, ITEM C-106. SEE DETAIL B1/GC501.
- TEMPORARY LIGHTED CLOSED RUNWAY MARKING FOR WORK AREA "D" AT BOTH ENDS OF RUNWAY 10-28 (28 END NOT SHOWN ON PLAN), ITEM C-106. SEE DETAIL B1/GC501.
- SIDA AREA GUARD BOOTH #27 (CHECK IN REQUIRED BEFORE ENTERING SIDA AREA)

A1 PHASING AND WORK AREA NOTES
SCALE: NOT TO SCALE

A4 LEGEND AND KEYED NOTES
SCALE: NOT TO SCALE



C&S Engineers, Inc.
41 State Street, Suite 600
Albany, New York 12207
Phone: 518-915-7349
www.cscos.com



RUNWAY 01-19 REHABILITATION AND LIGHTING UPGRADES
ALBANY INTERNATIONAL AIRPORT
COLONIE, NEW YORK

MARK	DATE	DESCRIPTION
REVISIONS		
		PROJECT NO: Q23014001
		DATE: FEBRUARY 2024
		DRAWN BY: M.D. HERNANDEZ
		DESIGNED BY: R.J. KOLLER
		CHECKED BY: C.D. BRUBACH

OVERALL CONSTRUCTION SAFETY AND PHASING PLAN

GC100

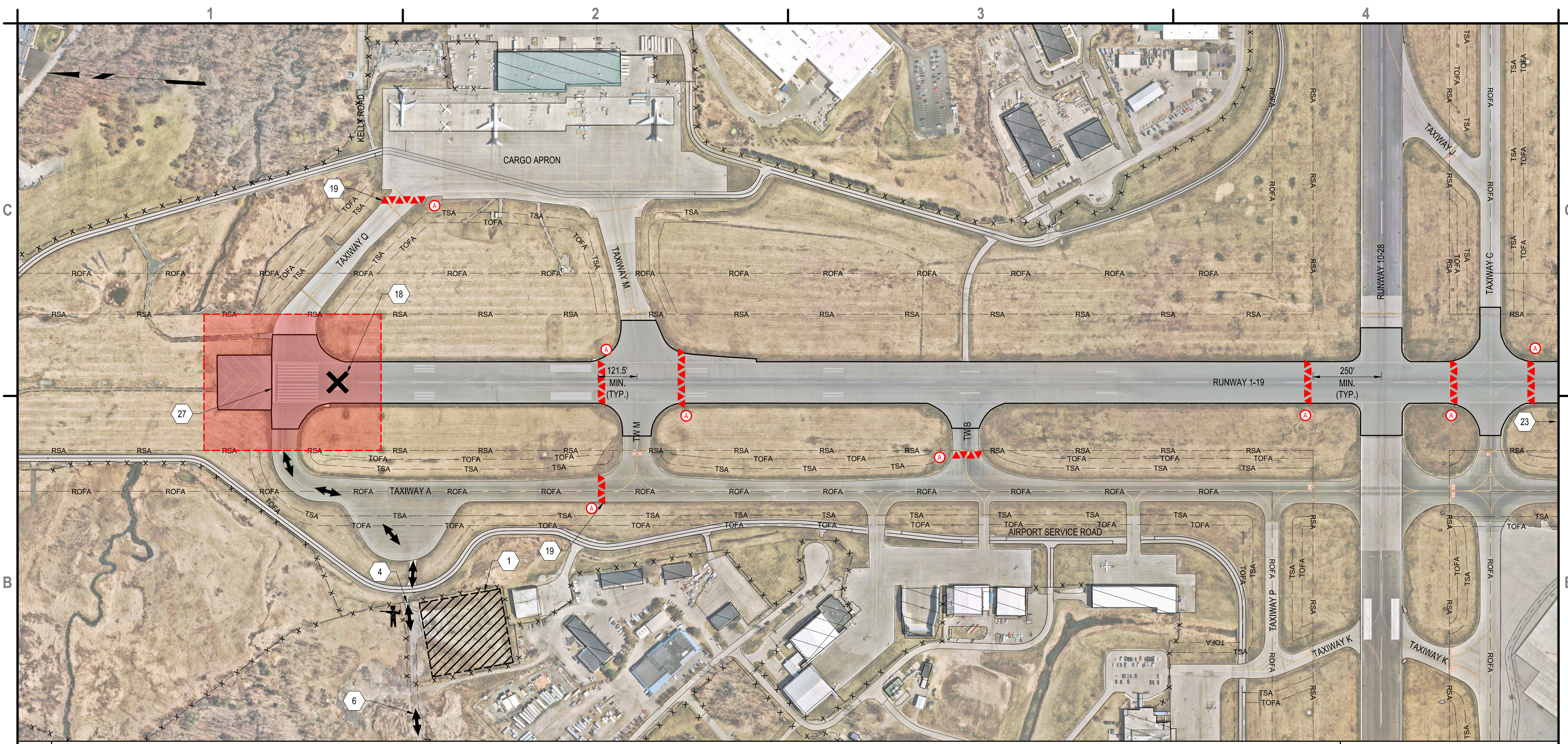

B1 CONSTRUCTION SAFETY AND PHASING PLAN - WORK AREA A
SCALE: 1" = 200'



WORK AREA:
 WORK AREA A - WORK AREA INCLUDES THE RUNWAY 19 END UP TO THE NORTHERN TOFA LIMIT OF TAXIWAY M (APPROXIMATE STA. 100+45 TO 106+95).

NOTES:

- ALL WORK IN AREA A MUST BE COMPLETED BETWEEN THE HOURS OF 10:00PM AND 5:00AM ONLY.
- BARRICADES SHALL BE PLACED AT THE TAXIWAY OBJECT FREE AREA (TOFA) LIMIT OF THE OPEN TAXIWAY OR RUNWAY SAFETY AREA (RSA) LIMIT OF THE OPEN RUNWAY UNLESS OTHERWISE SHOWN ON PLANS.
- FOR WORK AREAS A, B AND C BARRICADES ARE REQUIRED OUTSIDE THE LIMITS OF THIS PLAN, LOCATED SOUTH OF RUNWAY 10-28 AS FOLLOWS:
 - BARRICADES SHALL BE PLACED ON TAXIWAYS E, F AND A CLOSING ACCESS TO RUNWAY 1-19.
 - BARRICADES SHALL BE PLACED ON RUNWAY 1-19 ALONG BOTH SIDES OF TAXIWAY D FOR AIRCRAFT TAXI ROUTE TO CROSS THE RUNWAY.
 - CONFIRM SPECIFIC LOCATIONS WITH AIRPORT OPERATIONS.

WORK AREA A		
RUNWAY/TAXIWAY NAME	STATUS	
RUNWAY 01-19	CLOSED	
RUNWAY 10-28	OPEN	
TAXIWAY A	PARTIALLY CLOSED NORTH OF TAXIWAY M AND SOUTH OF TAXIWAY D	
TAXIWAY B	CLOSED	
TAXIWAY C	OPEN	
TAXIWAY D	OPEN	
TAXIWAY E	CLOSED	
TAXIWAY F	CLOSED	
TAXIWAY G	OPEN	
TAXIWAY M	OPEN	
TAXIWAY Q	CLOSED	

COORDINATE WITH OWNER THE ISSUING OF NOTAMS PERTAINING TO PAVEMENT CLOSURES AS INDICATED ABOVE.

- NORTH CONTRACTOR'S STAGING AREA
- CONTRACTOR'S ACCESS THROUGH EXISTING GATE 15A
- CONTRACTOR'S ACCESS TO WORK AREA "A"
- TEMPORARY LIGHTED CLOSED RUNWAY MARKING AT BOTH ENDS OF RUNWAY 1-19 (1 END NOT SHOWN ON PLAN), ITEM C-106. SEE DETAIL B1/GC501.
- TEMPORARY INTERLOCKING BARRICADES, ITEM C-106 (TYP.). SEE DETAIL A1/GC501.
- BARRICADE LOCATIONS TO BE PLACED ON RUNWAY AND TAXIWAYS TO PREVENT ACCESS TO RUNWAY 1-19. SEE NOTE 3 THIS SHEET.
- TEMPORARY THRESHOLD LIGHTS, JUMPER CABLES, AND CONDUIT, SEE DETAILS ON GC502

	WORK AREA "A" LIMITS		CLOSED RUNWAY MARKING
	BARRICADE LOCATION WITH WORK AREA DESIGNATION		CONSTRUCTION HAUL ROUTE
	FLAG PERSON LOCATION		AIRCRAFT TAXI ROUTE
	GATE GUARD LOCATION		

THIS SHEET IS INTENDED TO BE PRINTED IN COLOR

C&S COMPANIES
 C&S Engineers, Inc.
 41 State Street, Suite 600
 Albany, New York 12207
 Phone: 518-915-7349
 www.cscos.com



RUNWAY 01-19 REHABILITATION AND LIGHTING UPGRADES
ALBANY INTERNATIONAL AIRPORT
COLONIE, NEW YORK

MARK	DATE	DESCRIPTION
REVISIONS		
	PROJECT NO:	Q23014001
	DATE:	FEBRUARY 2024
	DRAWN BY:	M.D. HERNANDEZ
	DESIGNED BY:	R.J. KOLLER
	CHECKED BY:	C.D. BRUBACH

NO ALTERATION PERMITTED HEREON EXCEPT AS PROVIDED UNDER SECTION 7209 SUBDIVISION 2 OF THE NEW YORK EDUCATION LAW

CONSTRUCTION SAFETY AND PHASING PLAN - WORK AREA A

GC101

Feb 16, 2024, 1:25pm P:\Projects\23 - Albany County Airport Authority\Q23014001 - R17Y 1-19 Rehab\Design\CAD\Sheet Files\Q23014001_GC101.dwg

A1 PHASING AND WORK AREA NOTES
SCALE: NOT TO SCALE

A2 RUNWAY AND TAXIWAY OPERATIONAL REQUIREMENTS
SCALE: NOT TO SCALE

A3 KEYED NOTES
SCALE: NOT TO SCALE

A4 LEGEND
SCALE: NOT TO SCALE

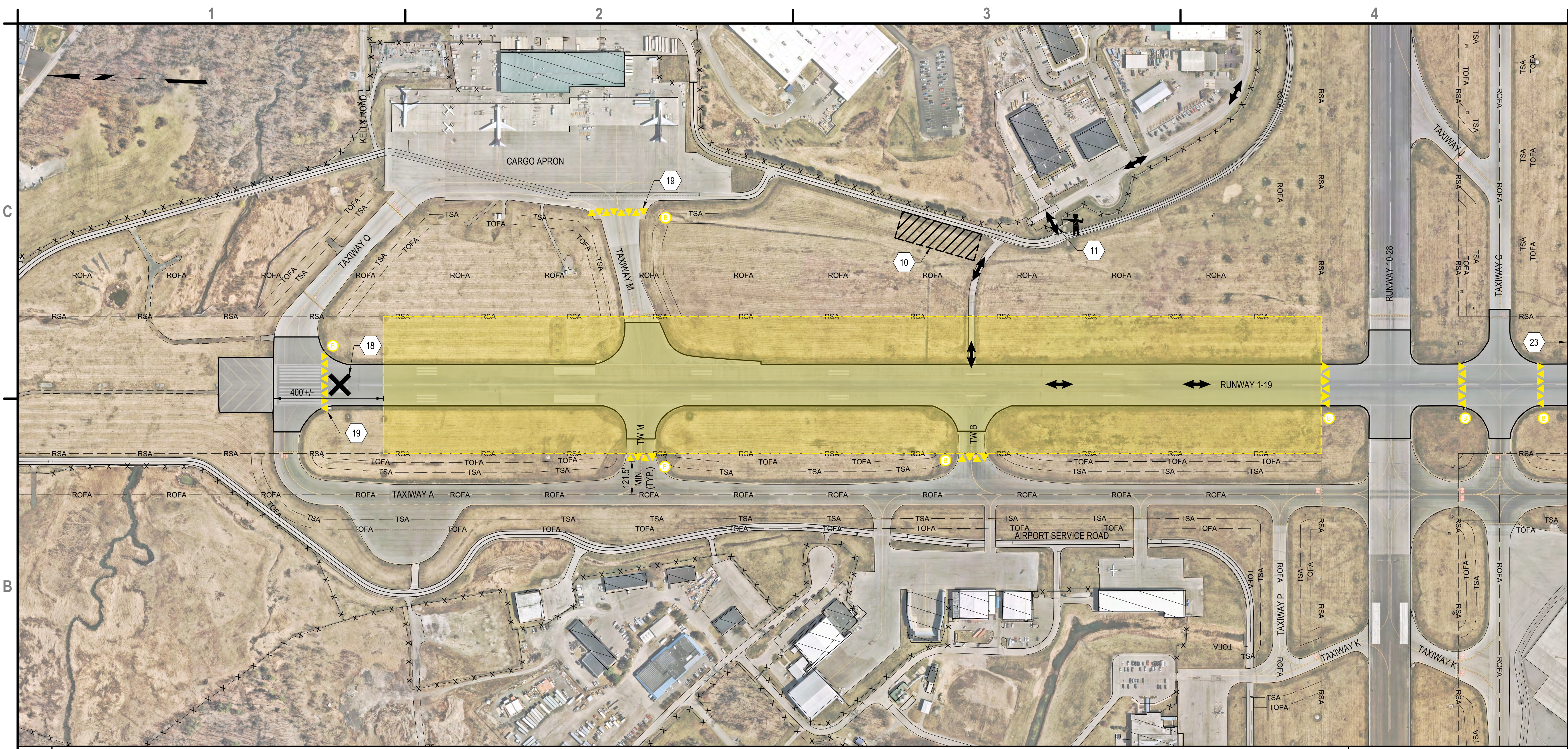

B1 CONSTRUCTION SAFETY AND PHASING PLAN - WORK AREA B
SCALE: 1" = 200'

WORK AREA:
WORK AREA B - WORK AREA INCLUDES THE AREA FROM THE NORTHERN TOFA LIMIT OF TAXIWAY M TO THE NORTHERN RSA LIMIT OF RUNWAY 10-28 (APPROXIMATE STA. 106+95 TO 141+10).

NOTES:

- ALL WORK IN AREA B MUST BE COMPLETED BETWEEN THE HOURS OF 10:00PM AND 5:00AM ONLY.
- BARRICADES SHALL BE PLACED AT THE TAXIWAY OBJECT FREE AREA (TOFA) LIMIT OF THE OPEN TAXIWAY OR RUNWAY SAFETY AREA (RSA) LIMIT OF THE OPEN RUNWAY UNLESS OTHERWISE SHOWN ON PLANS.
- FOR WORK AREAS A, B AND C BARRICADES ARE REQUIRED OUTSIDE THE LIMITS OF THIS PLAN, LOCATED SOUTH OF RUNWAY 10-28 AS FOLLOWS:
 - BARRICADES SHALL BE PLACED ON TAXIWAYS E, F AND A CLOSING ACCESS TO RUNWAY 1-19.
 - BARRICADES SHALL BE PLACED ON RUNWAY 1-19 ALONG BOTH SIDES OF TAXIWAY D FOR AIRCRAFT TAXI ROUTE TO CROSS THE RUNWAY.
 - CONFIRM SPECIFIC LOCATIONS WITH AIRPORT OPERATIONS.

WORK AREA B		
RUNWAY/TAXIWAY NAME		STATUS
RUNWAY 01-19		CLOSED
RUNWAY 10-28		OPEN
TAXIWAY A		PARTIALLY CLOSED SOUTH OF TAXIWAY F
TAXIWAY B		CLOSED
TAXIWAY C		OPEN
TAXIWAY D		OPEN
TAXIWAY E		CLOSED
TAXIWAY F		CLOSED
TAXIWAY G		OPEN
TAXIWAY M		CLOSED
TAXIWAY Q		OPEN

COORDINATE WITH OWNER THE ISSUING OF NOTAMS PERTAINING TO PAVEMENT CLOSURES AS INDICATED ABOVE.

- CONTRACTOR'S ACCESS TO WORK AREAS "B" & "C"
- ALTERNATIVE STAGING AREA FOR WORK AREAS "B" AND "C" FOR EQUIPMENT ONLY
- CONTRACTOR'S ACCESS THROUGH EXISTING GATE 14C
- TEMPORARY LIGHTED CLOSED RUNWAY MARKING AT BOTH ENDS OF RUNWAY 1-19 (1 END NOT SHOWN ON PLAN), ITEM C-106. SEE DETAIL B1/GC501.
- TEMPORARY INTERLOCKING BARRICADES, ITEM C-106 (TYP.). SEE DETAIL A1/GC501.
- BARRICADE LOCATIONS TO BE PLACED ON RUNWAY AND TAXIWAYS TO PREVENT ACCESS TO RUNWAY 1-19. SEE NOTE 3 THIS SHEET.

	WORK AREA "B" LIMITS		CLOSED RUNWAY MARKING
	BARRICADE LOCATION WITH WORK AREA DESIGNATION		CONSTRUCTION HAUL ROUTE
	FLAG PERSON LOCATION		AIRCRAFT TAXI ROUTE
	GATE GUARD LOCATION		

THIS SHEET IS INTENDED TO BE PRINTED IN COLOR

A1 PHASING AND WORK AREA NOTES
SCALE: NOT TO SCALE

A2 RUNWAY AND TAXIWAY OPERATIONAL REQUIREMENTS
SCALE: NOT TO SCALE

A3 KEYED NOTES
SCALE: NOT TO SCALE

A4 LEGEND
SCALE: NOT TO SCALE



C&S Engineers, Inc.
41 State Street, Suite 600
Albany, New York 12207
Phone: 518-915-7349
www.cscos.com



RUNWAY 01-19 REHABILITATION AND LIGHTING UPGRADES
ALBANY INTERNATIONAL AIRPORT
COLONIE, NEW YORK

MARK	DATE	DESCRIPTION
REVISIONS		

PROJECT NO: Q23014001
DATE: FEBRUARY 2024
DRAWN BY: M.D. HERNANDEZ
DESIGNED BY: R.J. KOLLER
CHECKED BY: C.D. BRUBACH

NO ALTERATION PERMITTED HEREON EXCEPT AS PROVIDED UNDER SECTION 7209 SUBDIVISION 2 OF THE NEW YORK EDUCATION LAW

CONSTRUCTION SAFETY AND PHASING PLAN - WORK AREA B

GC102

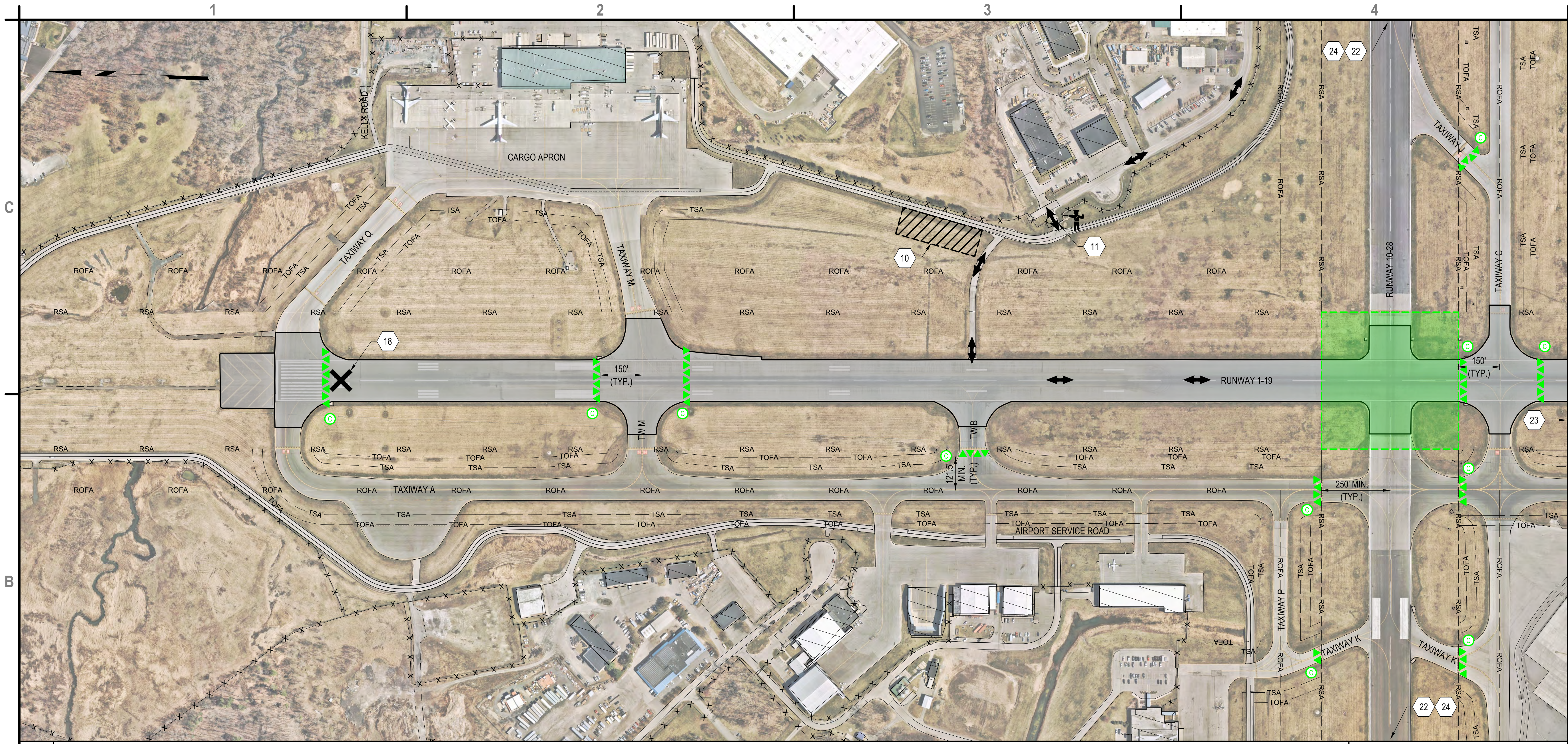

C&S Engineers, Inc.
 41 State Street, Suite 600
 Albany, New York 12207
 Phone: 518-915-7349
 www.cscos.com



**RUNWAY 01-19 REHABILITATION
 AND LIGHTING UPGRADES**

ALBANY INTERNATIONAL AIRPORT
COLONIE, NEW YORK

B1 CONSTRUCTION SAFETY AND PHASING PLAN - WORK AREA C

SCALE: 1" = 200'

- WORK AREA:**
 WORK AREA C - WORK AREA INCLUDES THE INTERSECTION OF RUNWAY 1-19 AND 10-28 INSIDE THE RSA OF THE RUNWAY 10-28 (500' WIDTH).
- NOTES:**
- WORK AREA C MUST BE COMPLETED ON WEEKEND NIGHTS ONLY BETWEEN 1:00AM SUNDAY TO 4:30AM SUNDAY AND BETWEEN 1:00AM SUNDAY TO 4:30AM SUNDAY. WORK HOURS MAY VARY BASED ON WEATHER AND AIRPORT OPERATIONAL NEEDS. CONTRACTOR IS ADVISED TO COORDINATE WITH OWNER TO PERFORM WORK IN WORK AREA C AS EARLY IN THE CONSTRUCTION SCHEDULE AS POSSIBLE WITH THE ASSUMPTION MULTIPLE WEEKEND TIME PERIODS WILL BE REQUIRED TO COMPLETE WORK AREA C. THE OWNER CANNOT GUARANTY WORK AREA C WILL BE AVAILABLE FOR WORK ON ANY GIVEN DAY BASED ON WEATHER OPERATIONAL NEEDS.
 - BARRICADES SHALL BE PLACED AT THE TAXIWAY OBJECT FREE AREA (TOFA) LIMIT OF THE OPEN TAXIWAY OR RUNWAY SAFETY AREA (RSA) LIMIT OF THE OPEN RUNWAY UNLESS OTHERWISE SHOWN ON PLANS.
 - FOR WORK AREAS A, B AND C BARRICADES ARE REQUIRED OUTSIDE THE LIMITS OF THIS PLAN, LOCATED SOUTH OF RUNWAY 10-28 AS FOLLOWS:
 - BARRICADES SHALL BE PLACED ON TAXIWAYS E, F AND A CLOSING ACCESS TO RUNWAY 1-19.
 - BARRICADES SHALL BE PLACED ON RUNWAY 1-19 ALONG BOTH SIDES OF TAXIWAY D FOR AIRCRAFT TAXI ROUTE TO CROSS THE RUNWAY.
 - CONFIRM SPECIFIC LOCATIONS WITH AIRPORT OPERATIONS.
 - FOR WORK AREA C BARRICADES ARE REQUIRED OUTSIDE THE LIMITS OF THIS PLAN, LOCATED EAST OF RUNWAY 1-19 AS FOLLOWS:
 - BARRICADES SHALL BE PLACED ON TAXIWAYS H AND N CLOSING ACCESS TO RUNWAY 10-28.
 - BARRICADES SHALL BE PLACED ON TAXIWAY C AT BOTH ENDS OF RUNWAY 10-28 CLOSING ACCESS TO RUNWAY 10-28.
 - CONFIRM SPECIFIC LOCATIONS WITH AIRPORT OPERATIONS.

WORK AREA C		
RUNWAY/TAXIWAY NAME		STATUS
RUNWAY 01-19		CLOSED
RUNWAY 10-28		CLOSED
TAXIWAY A		CLOSED
TAXIWAY B		CLOSED
TAXIWAY C		CLOSED
TAXIWAY D		CLOSED
TAXIWAY E		CLOSED
TAXIWAY F		CLOSED
TAXIWAY G		CLOSED
TAXIWAY M		CLOSED
TAXIWAY Q		CLOSED
ALL OTHER TAXIWAYS		CLOSED

COORDINATE WITH OWNER THE ISSUING OF NOTAMS PERTAINING TO PAVEMENT CLOSURES AS INDICATED ABOVE.

- CONTRACTOR'S ACCESS TO WORK AREAS "B" & "C"
- ALTERNATIVE STAGING AREA FOR WORK AREAS "B" AND "C" FOR EQUIPMENT ONLY
- CONTRACTOR'S ACCESS THROUGH EXISTING GATE 14C
- TEMPORARY LIGHTED CLOSED RUNWAY MARKING AT BOTH ENDS OF RUNWAY 1-19 (1 END NOT SHOWN ON PLAN), ITEM C-106. SEE DETAIL B1/GC501.
- TEMPORARY INTERLOCKING BARRICADES, ITEM C-106 (TYP.). SEE DETAIL A1/GC501.
- TEMPORARY LIGHTED CLOSED RUNWAY MARKING FOR WORK AREA "D" AT BOTH ENDS OF RUNWAY 10-28 (BOTH ENDS NOT SHOWN ON PLAN), ITEM C-106. SEE DETAIL B1/GC501.
- BARRICADE LOCATIONS TO BE PLACED ON RUNWAY AND TAXIWAYS TO PREVENT ACCESS TO RUNWAY 1-19. SEE NOTE 3 THIS SHEET.
- BARRICADE LOCATIONS TO BE PLACED ON RUNWAY AND TAXIWAYS TO PREVENT ACCESS TO RUNWAY 10-28. SEE NOTE 4 THIS SHEET.

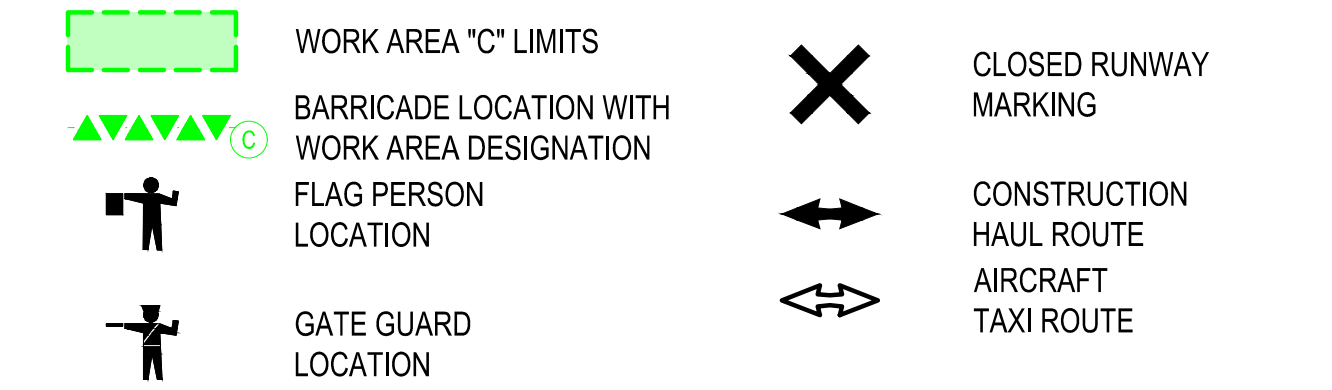

**THIS SHEET IS INTENDED
TO BE PRINTED IN COLOR**

A1 PHASING AND WORK AREA NOTES
SCALE: NOT TO SCALE

A2 RUNWAY AND TAXIWAY OPERATIONAL REQUIREMENTS
SCALE: NOT TO SCALE

A3 KEYED NOTES
SCALE: NOT TO SCALE

A4 LEGEND
SCALE: NOT TO SCALE

MARK	DATE	DESCRIPTION

REVISIONS	
PROJECT NO:	Q23014001
DATE:	FEBRUARY 2024
DRAWN BY:	M.D. HERNANDEZ
DESIGNED BY:	R.J. KOLLER
CHECKED BY:	C.D. BRUBACH

NO ALTERATION PERMITTED HEREON EXCEPT AS PROVIDED UNDER SECTION 7209 SUBDIVISION 2 OF THE NEW YORK EDUCATION LAW

**CONSTRUCTION
SAFETY AND
PHASING PLAN -
WORK AREA C**

GC103

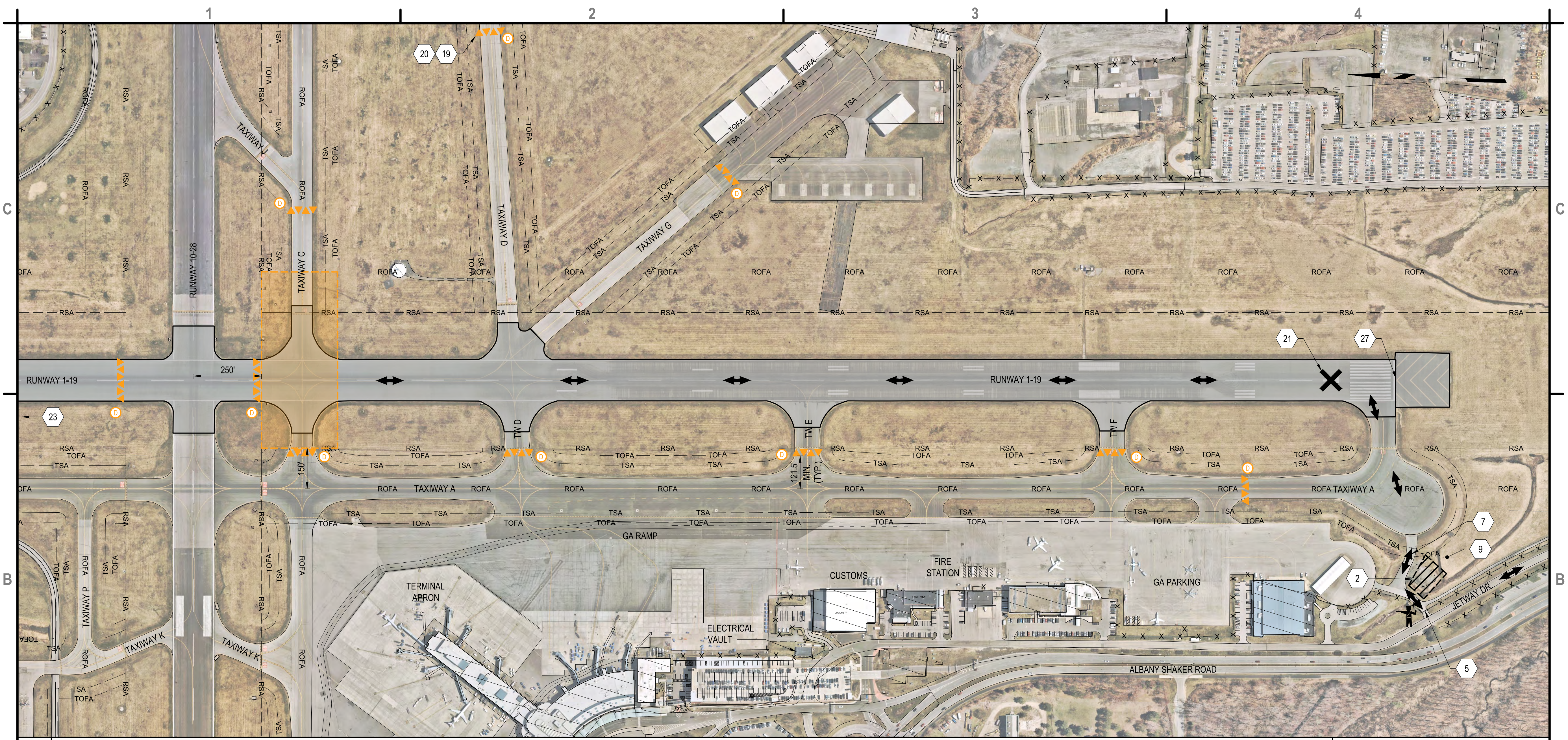

B1 CONSTRUCTION SAFETY AND PHASING PLAN - WORK AREA D
SCALE: 1" = 200'

WORK AREA:
WORK AREA D - WORK AREA INCLUDES THE AREA FROM THE SOUTHERN RSA LIMITS OF RUNWAY 10-28 TO THE SOUTHERN TOFA LIMIT OF TAXIWAY C (APPROXIMATE 146+10 TO 148+95).

NOTES:

- ALL WORK IN AREA D MUST BE COMPLETED BETWEEN THE HOURS OF 10:00PM AND 5:00AM ONLY.
- BARRICADES SHALL BE PLACED AT THE TAXIWAY OBJECT FREE AREA (TOFA) LIMIT OF THE OPEN TAXIWAY OR RUNWAY SAFETY AREA (RSA) LIMIT OF THE OPEN RUNWAY UNLESS OTHERWISE SHOWN ON PLANS.
- FOR WORK AREAS D AND E BARRICADES ARE REQUIRED, OUTSIDE THE LIMITS OF THIS PLAN, LOCATED NORTH OF RUNWAY 10-28 AS FOLLOWS:
 - BARRICADES SHALL BE PLACED ON TAXIWAYS A, B AND Q CLOSING ACCESS TO RUNWAY 1-19.
 - BARRICADES SHALL BE PLACED ON RUNWAY 1-19 ALONG BOTH SIDES OF TAXIWAY M FOR AIRCRAFT TAXI ROUTE TO CROSS THE RUNWAY.
 - CONFIRM SPECIFIC LOCATIONS WITH AIRPORT OPERATIONS.

WORK AREA D		
RUNWAY/TAXIWAY NAME		STATUS
RUNWAY 01-19		CLOSED
RUNWAY 10-28		OPEN
TAXIWAY A		PARTIALLY CLOSED SOUTH OF TAXIWAY F
TAXIWAY B		CLOSED
TAXIWAY C		PARTIALLY CLOSED BETWEEN TAXIWAYS A AND J
TAXIWAY D		OPEN
TAXIWAY E		CLOSED
TAXIWAY F		CLOSED
TAXIWAY G		OPEN
TAXIWAY M		CLOSED
TAXIWAY Q		OPEN

COORDINATE WITH OWNER THE ISSUING OF NOTAMS PERTAINING TO PAVEMENT CLOSURES AS INDICATED ABOVE.

- SOUTH CONTRACTOR'S STAGING AREA
- CONTRACTOR'S ACCESS THROUGH EXISTING GATE 6
- CONTRACTOR'S ACCESS TO WORK AREAS "D", "E", "F" & "G"
- ENGINEER'S FIELD OFFICE, FINAL LOCATION TO BE DETERMINED BY OWNER
- TEMPORARY INTERLOCKING BARRICADES, ITEM C-106 (TYP.), SEE DETAIL A1/GC501.
- BARRICADE LOCATION TO BE IMMEDIATELY WEST OF TAXIWAY INTERSECTION
- TEMPORARY LIGHTED CLOSED RUNWAY MARKING AT BOTH ENDS OF RUNWAY 1-19 (19 END NOT SHOWN ON PLAN), ITEM C-106. SEE DETAIL B1/GC501.
- BARRICADE LOCATIONS TO BE PLACED ON RUNWAY AND TAXIWAYS TO PREVENT ACCESS TO RUNWAY 1-19. SEE NOTE 3 THIS SHEET.
- TEMPORARY THRESHOLD LIGHTS, JUMPER CABLES, AND CONDUIT, SEE DETAILS ON GC502

	WORK AREA "D" LIMITS		CLOSED RUNWAY MARKING
	BARRICADE LOCATION WITH WORK AREA DESIGNATION		CONSTRUCTION HAUL ROUTE
	FLAG PERSON LOCATION		AIRCRAFT TAXI ROUTE
	GATE GUARD LOCATION		TAXI ROUTE

THIS SHEET IS INTENDED TO BE PRINTED IN COLOR

A1 PHASING AND WORK AREA NOTES
SCALE: NOT TO SCALE

A2 RUNWAY AND TAXIWAY OPERATIONAL REQUIREMENTS
SCALE: NOT TO SCALE

A3 KEYED NOTES
SCALE: NOT TO SCALE

A4 LEGEND
SCALE: NOT TO SCALE



C&S Engineers, Inc.
41 State Street, Suite 600
Albany, New York 12207
Phone: 518-915-7349
www.cscos.com



RUNWAY 01-19 REHABILITATION AND LIGHTING UPGRADES
ALBANY INTERNATIONAL AIRPORT
COLONIE, NEW YORK

MARK	DATE	DESCRIPTION
REVISIONS		
PROJECT NO: Q23014001		
DATE: FEBRUARY 2024		
DRAWN BY: M.D. HERNANDEZ		
DESIGNED BY: R.J. KOLLER		
CHECKED BY: C.D. BRUBACH		

NO ALTERATION PERMITTED HEREON EXCEPT AS PROVIDED UNDER SECTION 7209 SUBDIVISION 2 OF THE NEW YORK EDUCATION LAW

CONSTRUCTION SAFETY AND PHASING PLAN - WORK AREA D

GC104



C&S Engineers, Inc.
41 State Street, Suite 600
Albany, New York 12207
Phone: 518-915-7349
www.cscos.com



RUNWAY 01-19 REHABILITATION AND LIGHTING UPGRADES

ALBANY INTERNATIONAL AIRPORT COLONIE, NEW YORK

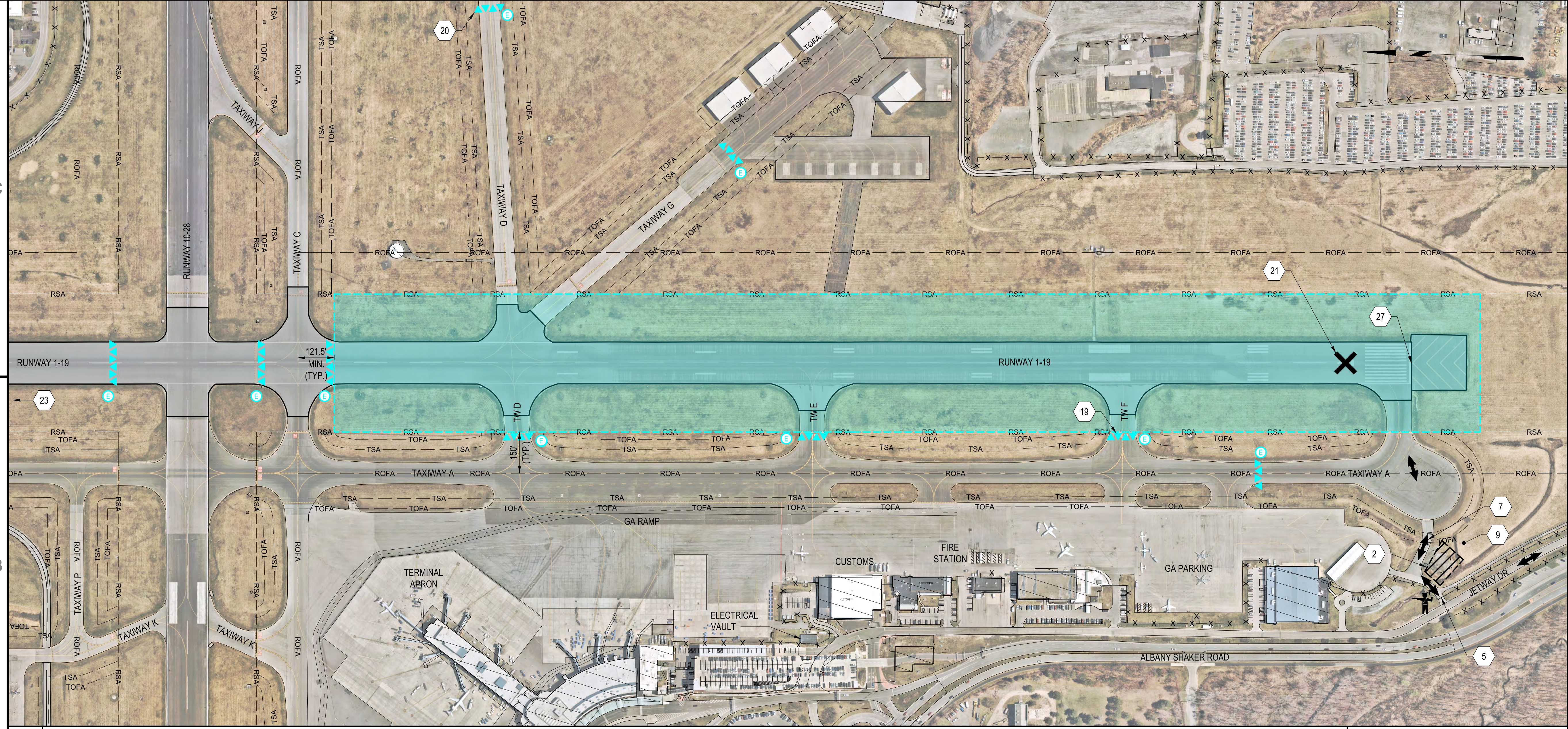

B1 CONSTRUCTION SAFETY AND PHASING PLAN - WORK AREA E
SCALE: 1" = 200'

WORK AREA:
WORK AREA E - WORK AREA INCLUDES THE RUNWAY 01 END TO THE SOUTHERN TOFA LIMIT OF TAXIWAY C (APPROXIMATE STA. 148+95 TO 190+45), AS WELL AS TAXIWAY E TO THE WEST TOFA LIMIT OF TAXIWAY A.

WORK AREA E1 - WORK AREA INCLUDES THE INTERSECTION OF TAXIWAY D CROSSING RUNWAY 1-19. WORK AREA E1 CANNOT BE CONCURRENT WITH WORK AREA D.

NOTES:

- ALL WORK IN AREA E MUST BE COMPLETED BETWEEN THE HOURS OF 10:00PM AND 5:00AM ONLY.
- BARRICADES SHALL BE PLACED AT THE TAXIWAY OBJECT FREE AREA (TOFA) LIMIT OF THE OPEN TAXIWAY OR RUNWAY SAFETY AREA (RSA) LIMIT OF THE OPEN RUNWAY UNLESS OTHERWISE SHOWN ON PLANS.
- FOR WORK AREAS D AND E BARRICADES ARE REQUIRED, OUTSIDE THE LIMITS OF THIS PLAN, LOCATED NORTH OF RUNWAY 10-28 AS FOLLOWS:
 - BARRICADES SHALL BE PLACED ON TAXIWAYS A, B AND Q CLOSING ACCESS TO RUNWAY 1-19.
 - BARRICADES SHALL BE PLACED ON RUNWAY 1-19 ALONG BOTH SIDES OF TAXIWAY M FOR AIRCRAFT TAXI ROUTE TO CROSS THE RUNWAY.
 - CONFIRM SPECIFIC LOCATIONS WITH AIRPORT OPERATIONS.

WORK AREA E		
RUNWAY/TAXIWAY NAME		STATUS
RUNWAY 01-19		CLOSED
RUNWAY 10-28		OPEN
TAXIWAY A		PARTIALLY CLOSED SOUTH OF TAXIWAY D
TAXIWAY B		CLOSED
TAXIWAY C		OPEN
TAXIWAY D		PARTIALLY CLOSED WEST OF T-HANGAR DURING WORK IN AREA E1
TAXIWAY E		CLOSED
TAXIWAY F		CLOSED
TAXIWAY G		CLOSED
TAXIWAY M		OPEN
TAXIWAY Q		CLOSED

COORDINATE WITH OWNER THE ISSUING OF NOTAMS PERTAINING TO PAVEMENT CLOSURES AS INDICATED ABOVE.

- SOUTH CONTRACTOR'S STAGING AREA
- CONTRACTOR'S ACCESS THROUGH EXISTING GATE 6
- CONTRACTOR'S ACCESS TO WORK AREAS "D", "E", "F" & "G"
- ENGINEER'S FIELD OFFICE, FINAL LOCATION TO BE DETERMINED BY OWNER
- TEMPORARY INTERLOCKING BARRICADES, ITEM C-106 (TYP.), SEE DETAIL A1/GC501.
- BARRICADE LOCATION TO BE IMMEDIATELY WEST OF TAXIWAY INTERSECTION
- TEMPORARY LIGHTED CLOSED RUNWAY MARKING AT BOTH ENDS OF RUNWAY 1-19 (19 END NOT SHOWN ON PLAN), ITEM C-106. SEE DETAIL B1/GC501.
- BARRICADE LOCATIONS TO BE PLACED ON RUNWAY AND TAXIWAYS TO PREVENT ACCESS TO RUNWAY 1-19. SEE NOTE 3 THIS SHEET.
- TEMPORARY THRESHOLD LIGHTS, JUMPER CABLES, AND CONDUIT, SEE DETAILS ON GC502

LEGEND

	WORK AREA "E" LIMITS		CLOSED RUNWAY MARKING
	BARRICADE LOCATION WITH WORK AREA DESIGNATION		CONSTRUCTION HAUL ROUTE
	FLAG PERSON LOCATION		AIRCRAFT TAXI ROUTE
	GATE GUARD LOCATION		

THIS SHEET IS INTENDED TO BE PRINTED IN COLOR

MARK	DATE	DESCRIPTION
REVISIONS		

PROJECT NO: Q23014001
DATE: FEBRUARY 2024
DRAWN BY: M.D. HERNANDEZ
DESIGNED BY: R.J. KOLLER
CHECKED BY: C.D. BRUBACH

CONSTRUCTION SAFETY AND PHASING PLAN - WORK AREA E

GC105

Feb 16, 2024 - 12:25pm P:\Projects\23 - Albany County Airport Authority\Q23014001 - R1Y1 1-19 Rehab\Design\A1D1\Sheet Files\Q23014001_GC105.dwg

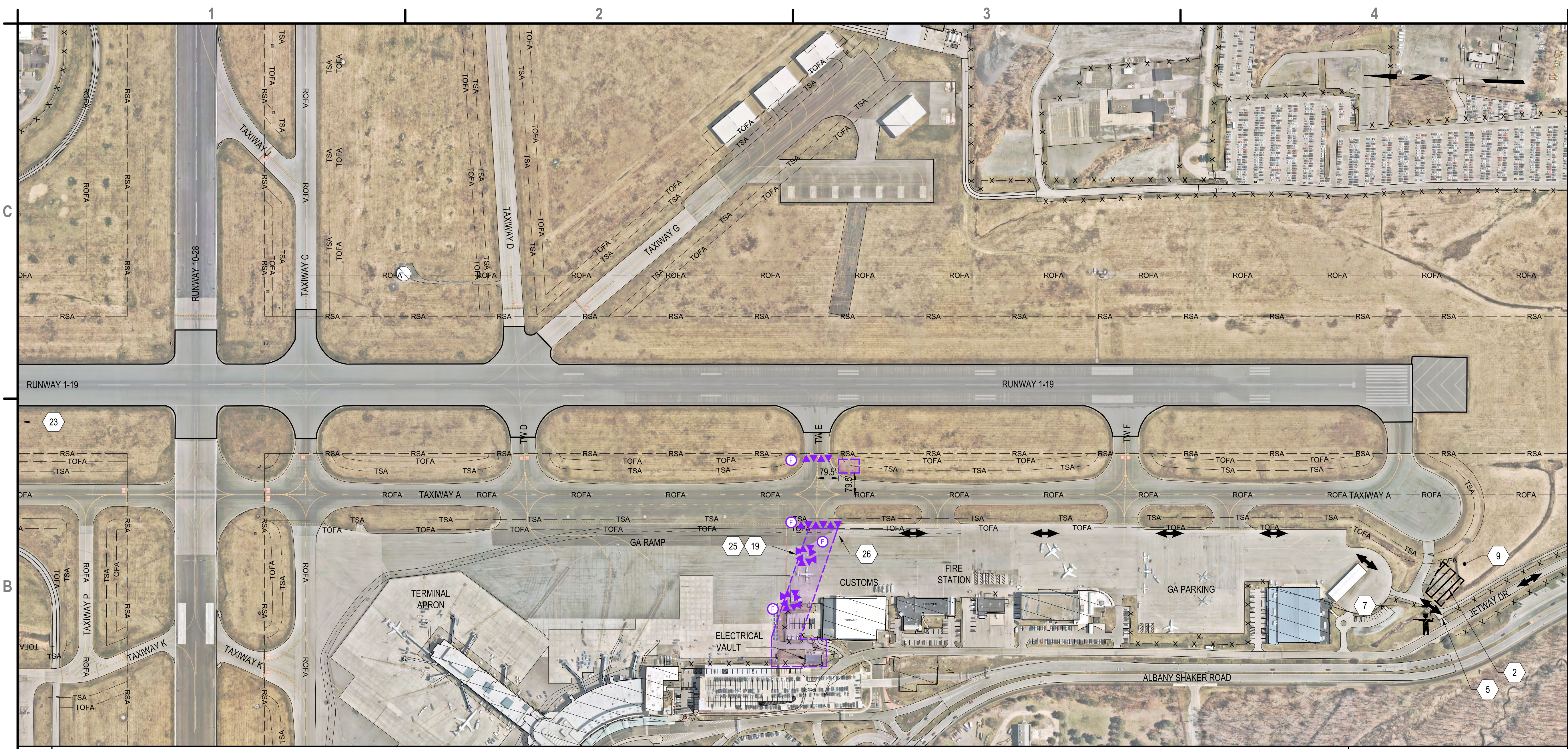

B1 CONSTRUCTION SAFETY AND PHASING PLAN - WORK AREA F
SCALE: 1" = 200'

WORK AREA:
WORK AREA F - WORK AREA INCLUDES THE AREA FROM THE TAXIWAY A WEST OF A LIMIT TO THE ELECTRICAL VAULT. FOLLOWING THE AIRFIELD ELECTRICAL HOMERUN DUCT BANK ROUTE.

NOTES:

- ALL WORK IN AREA F MUST BE COMPLETED BETWEEN THE HOURS OF 10:00PM AND 5:00AM ONLY.
- BARRICADE PLACEMENT FOR WORK IN AREA F MUST BE COORDINATED WITH THE OWNER FOR EACH SMALL WORK AREA.
- WORK AREA F MUST BE COMPLETED DURING VFR CONDITIONS WITH THE OWNER TO ENSURE AIRFIELD CABLES CONTAINED IN ELECTRICAL STRUCTURES AND/OR DUCT BANKS ARE DEENERGIZED BEFORE CONTRACTOR REMOVES AND REPLACES CABLES WITHIN WORK AREA F.
- COORDINATE WITH OWNER THE ISSUING OF NOTAM RESTRICTING TAXIWAY A TO ADG III AIRCRAFT OR SMALLER (MAX. 118' WINGSPAN) WHILE WORK TAKES PLACE IN WORK AREA F EAST OF TAXIWAY F.

WORK AREA F	
RUNWAY/TAXIWAY NAME	STATUS
RUNWAY 01-19	
RUNWAY 10-28	
TAXIWAY A	OPEN TO AIRCRAFT OPERATIONS DURING WORK IN AREA F, CONTINGENT ON LIMITATIONS/RULES STIPULATED FOR WORK AREAS
TAXIWAY B	
TAXIWAY C	
TAXIWAY D	
TAXIWAY E	CLOSED
TAXIWAY F	
TAXIWAY G	OPEN TO AIRCRAFT OPERATIONS DURING WORK IN AREA F, CONTINGENT ON LIMITATION/RULES STIPULATED FOR WORK AREAS
TAXIWAY M	
TAXIWAY Q	

COORDINATE WITH OWNER THE ISSUING OF NOTAMS PERTAINING TO PAVEMENT CLOSURES AS INDICATED ABOVE.

- SOUTH CONTRACTOR'S STAGING AREA
- CONTRACTOR'S ACCESS THROUGH EXISTING GATE 6
- CONTRACTOR'S ACCESS TO WORK AREAS "D", "E", "F" & "G"
- ENGINEER'S FIELD OFFICE, FINAL LOCATION TO BE DETERMINED BY OWNER
- TEMPORARY INTERLOCKING BARRICADES, ITEM C-106 (TYP.), SEE DETAIL A1/GC501.
- BARRICADE LOCATIONS TO BE PLACED ON RUNWAY AND TAXIWAYS TO PREVENT ACCESS TO RUNWAY 1-19. SEE NOTE 3 THIS SHEET.
- ENCLOSE AREA SURROUNDING ELECTRICAL STRUCTURE (30'X30' MIN.) WITH TEMPORARY BARRICADES WHILE PERSONNEL AND VEHICLES ARE IN WORK AREA "F". CONTRACTOR'S PERSONNEL AND VEHICLES SHALL REMAIN WITHIN BARRICADED AREAS WHILE WORK TAKES PLACE IN WORK AREA "F"
- TWO-WAY TRAFFIC SHALL BE MAINTAINED ON VSR AT ALL TIMES

	WORK AREA "F" LIMITS		CLOSED RUNWAY MARKING
	BARRICADE LOCATION WITH WORK AREA DESIGNATION		CONSTRUCTION HAUL ROUTE
	FLAG PERSON LOCATION		AIRCRAFT TAXI ROUTE
	GATE GUARD LOCATION		

THIS SHEET IS INTENDED TO BE PRINTED IN COLOR

A1 PHASING AND WORK AREA NOTES
SCALE: NOT TO SCALE

A2 RUNWAY AND TAXIWAY OPERATIONAL REQUIREMENTS
SCALE: NOT TO SCALE

A3 KEYED NOTES
SCALE: NOT TO SCALE

A4 LEGEND
SCALE: NOT TO SCALE



C&S Engineers, Inc.
41 State Street, Suite 600
Albany, New York 12207
Phone: 518-915-7349
www.cscos.com



RUNWAY 01-19 REHABILITATION AND LIGHTING UPGRADES
ALBANY INTERNATIONAL AIRPORT
COLONIE, NEW YORK

MARK	DATE	DESCRIPTION
REVISIONS		
PROJECT NO:	Q23014001	
DATE:	FEBRUARY 2024	
DRAWN BY:	M.D. HERNANDEZ	
DESIGNED BY:	R.J. KOLLER	
CHECKED BY:	C.D. BRUBACH	

NO ALTERATION PERMITTED HEREON EXCEPT AS PROVIDED UNDER SECTION 7209 SUBDIVISION 2 OF THE NEW YORK EDUCATION LAW

CONSTRUCTION SAFETY AND PHASING PLAN - WORK AREA F

GC106

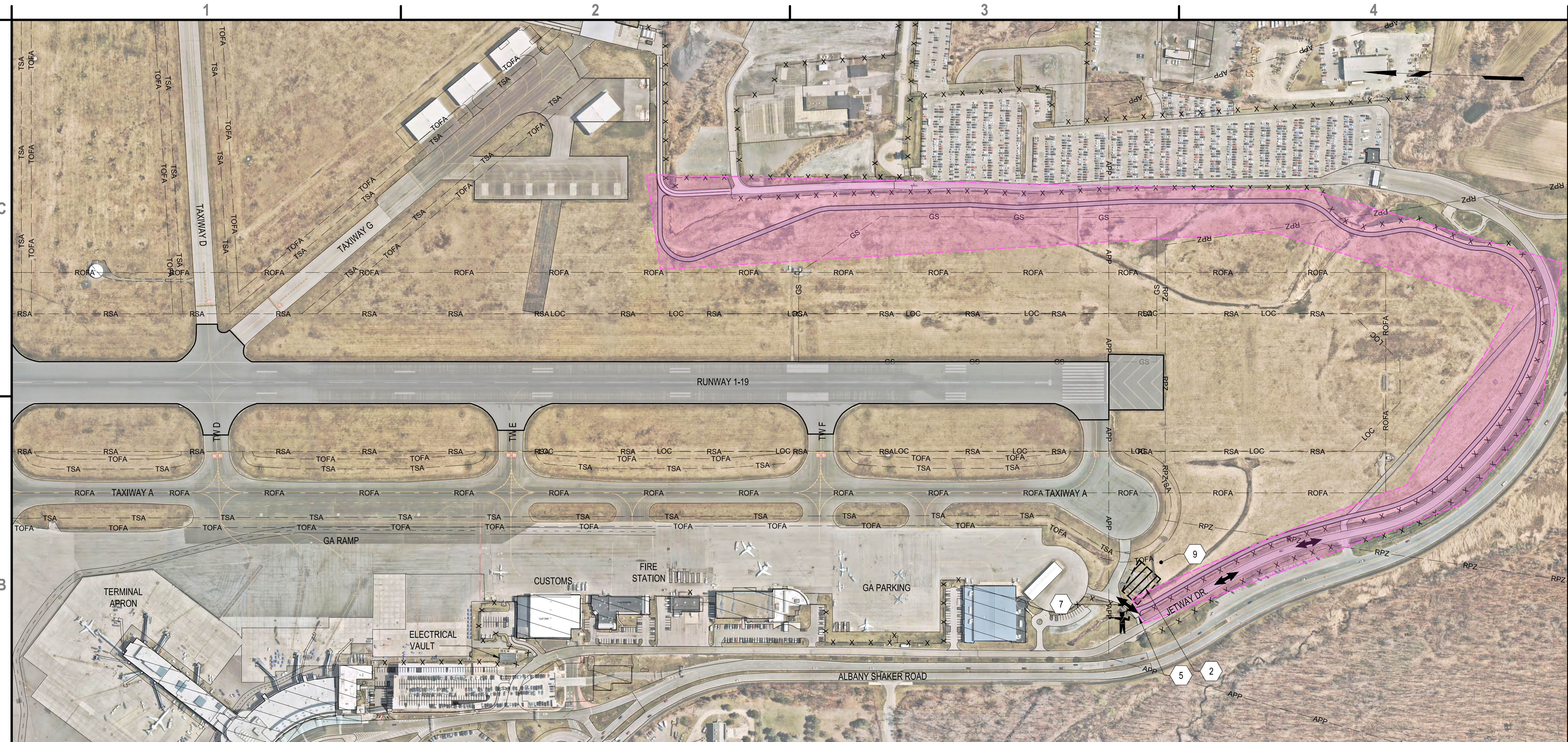

C&S Engineers, Inc.
 41 State Street, Suite 600
 Albany, New York 12207
 Phone: 518-915-7349
 www.cscos.com



RUNWAY 01-19 REHABILITATION AND LIGHTING UPGRADES
ALBANY INTERNATIONAL AIRPORT
COLONIE, NEW YORK

B1 CONSTRUCTION SAFETY AND PHASING PLAN - WORK AREA G
 SCALE: 1" = 200'

WORK AREA:
 WORK AREA G - WORK AREA INCLUDES THE AREA OF SERVICE ROAD ALONG THE PERIMETER FENCE PAST THE SOUTHERN END OF RUNWAY 1-19.

NOTES:
 1. ALL WORK IN AREA G MUST BE COMPLETED BETWEEN THE HOURS OF 10:00PM AND 5:00AM ONLY

WORK AREA G	
RUNWAY/TAXIWAY NAME	STATUS
RUNWAY 01-19	
RUNWAY 10-28	
TAXIWAY A	
TAXIWAY B	
TAXIWAY C	
TAXIWAY D	
TAXIWAY E	
TAXIWAY F	
TAXIWAY G	
TAXIWAY M	
TAXIWAY Q	

ALL AIRPORT PAVEMENTS MAY BE OPEN TO AIRCRAFT OPERATIONS DURING WORK IN WORK AREA G, CONTINGENT ON LIMITATIONS / RULES STIPULATED FOR WORK AREAS RUNNING CONCURRENTLY

- 2. SOUTH CONTRACTOR'S STAGING AREA
- 5. CONTRACTOR'S ACCESS THROUGH EXISTING GATE 6
- 7. CONTRACTOR'S ACCESS TO WORK AREAS "D", "E", "F" & "G"
- 9. ENGINEER'S FIELD OFFICE, FINAL LOCATION TO BE DETERMINED BY OWNER

	WORK AREA "G" LIMITS		CLOSED RUNWAY MARKING
	BARRICADE LOCATION WITH WORK AREA DESIGNATION		CONSTRUCTION HAUL ROUTE
	FLAG PERSON LOCATION		AIRCRAFT TAXI ROUTE
	GATE GUARD LOCATION		

THIS SHEET IS INTENDED TO BE PRINTED IN COLOR

MARK	DATE	DESCRIPTION
REVISIONS		

PROJECT NO:	Q23014001
DATE:	FEBRUARY 2024
DRAWN BY:	M.D. HERNANDEZ
DESIGNED BY:	R.J. KOLLER
CHECKED BY:	C.D. BRUBACH

NO ALTERATION PERMITTED HEREON EXCEPT AS PROVIDED UNDER SECTION 7209 SUBDIVISION 2 OF THE NEW YORK EDUCATION LAW

CONSTRUCTION SAFETY AND PHASING PLAN - WORK AREA G

GC107

A1 PHASING AND WORK AREA NOTES
 SCALE: NOT TO SCALE

A2 RUNWAY AND TAXIWAY OPERATIONAL REQUIREMENTS
 SCALE: NOT TO SCALE

A3 KEYED NOTES
 SCALE: NOT TO SCALE

A4 LEGEND
 SCALE: NOT TO SCALE

COORDINATE TABLE					
POINT ID	LATITUDE	LONGITUDE	DESCRIPTION	MAX. HEIGHT	ELEV.
A	N42° 45' 40.22"	W73° 48' 15.73"	WORK AREA A	20'	260.00'
B	N42° 45' 33.81"	W73° 48' 15.45"	WORK AREA A	20'	259.08'
C	N42° 45' 33.66"	W73° 48' 22.15"	WORK AREA A	20'	261.87'
D	N42° 45' 40.07"	W73° 48' 22.43"	WORK AREA A	20'	262.28'
E	N42° 45' 33.81"	W73° 48' 15.45"	WORK AREA B	20'	259.08'
F	N42° 45' 00.08"	W73° 48' 13.99"	WORK AREA B	20'	276.88'
G	N42° 44' 59.92"	W73° 48' 20.69"	WORK AREA B	20'	274.50'
H	N42° 45' 33.66"	W73° 48' 22.15"	WORK AREA B	20'	261.87'
I	N42° 45' 00.08"	W73° 48' 13.99"	WORK AREA C	20'	276.88'
J	N42° 44' 55.14"	W73° 48' 13.78"	WORK AREA C	20'	274.15'
K	N42° 44' 54.98"	W73° 48' 20.48"	WORK AREA C	20'	272.25'
L	N42° 44' 59.92"	W73° 48' 20.69"	WORK AREA C	20'	274.50'
M	N42° 44' 55.19"	W73° 48' 11.77"	WORK AREA D	20'	274.49'
N	N42° 44' 52.41"	W73° 48' 11.65"	WORK AREA D	20'	274.35'
O	N42° 44' 52.20"	W73° 48' 20.36"	WORK AREA D	20'	271.16'
P	N42° 44' 54.98"	W73° 48' 20.48"	WORK AREA D	20'	272.25'
Q	N42° 44' 52.36"	W73° 48' 13.66"	WORK AREA E	20'	273.52'
R	N42° 44' 11.40"	W73° 48' 11.89"	WORK AREA E	20'	283.16'

COORDINATE TABLE					
POINT ID	LATITUDE	LONGITUDE	DESCRIPTION	MAX. HEIGHT	ELEV.
S	N42° 44' 11.24"	W73° 48' 18.59"	WORK AREA E	20'	280.31'
T	N42° 44' 52.20"	W73° 48' 20.36"	WORK AREA E	20'	271.16'
U	N42° 44' 35.33"	W73° 48' 23.30"	WORK AREA F	20'	275.12'
V	N42° 44' 33.58"	W73° 48' 19.83"	WORK AREA F	20'	276.45'
W	N42° 44' 34.53"	W73° 48' 30.01"	WORK AREA F	20'	271.93'
X	N42° 44' 36.50"	W73° 48' 30.09"	WORK AREA F	20'	271.85'
Y	N42° 45' 32.10"	W73° 48' 29.60"	NORTH STAGING	20'	262.81'
Z	N42° 45' 29.20"	W73° 48' 28.76"	NORTH STAGING	20'	265.73'
AA	N42° 45' 28.63"	W73° 48' 32.37"	NORTH STAGING	20'	266.58'
BB	N42° 45' 31.53"	W73° 48' 33.20"	NORTH STAGING	20'	264.10'
CC	N42° 44' 12.48"	W73° 48' 23.92"	SOUTH STAGING	20'	277.90'
DD	N42° 44' 11.69"	W73° 48' 24.81"	SOUTH STAGING	20'	277.12'
EE	N42° 44' 12.49"	W73° 48' 26.10"	SOUTH STAGING	20'	276.63'
FF	N42° 44' 13.05"	W73° 48' 25.45"	SOUTH STAGING	20'	277.02'
GG	N42° 44' 33.76"	W73° 48' 20.07"	HOME RUN	20'	276.23'
HH	N42° 44' 35.39"	W73° 48' 24.61"	HOME RUN	20'	274.31'
II	N42° 44' 36.24"	W73° 48' 29.55"	HOME RUN	20'	272.07'
JJ	N42° 44' 12.69"	W73° 48' 25.80"	WORK AREA G	20'	276.78'

COORDINATE TABLE					
POINT ID	LATITUDE	LONGITUDE	DESCRIPTION	MAX. HEIGHT	ELEV.
KK	N42° 44' 02.99"	W73° 48' 19.87"	WORK AREA G	20'	281.55'
LL	N42° 43' 59.35"	W73° 48' 10.98"	WORK AREA G	20'	287.64'
MM	N42° 44' 08.12"	W73° 48' 07.76"	WORK AREA G	20'	284.91'
NN	N42° 44' 29.96"	W73° 48' 10.54"	WORK AREA G	20'	280.62'
OO	N42° 44' 30.57"	W73° 48' 05.94"	WORK AREA G	20'	282.21'
PP	N42° 44' 06.65"	W73° 48' 05.70"	WORK AREA G	20'	286.45'
QQ	N42° 43' 57.69"	W73° 48' 08.80"	WORK AREA G	20'	282.22'
RR	N42° 43' 58.23"	W73° 48' 15.98"	WORK AREA G	20'	281.70'
SS	N42° 44' 00.95"	W73° 48' 20.67"	WORK AREA G	20'	280.05'
TT	N42° 44' 12.29"	W73° 48' 27.02"	WORK AREA G	20'	276.45'

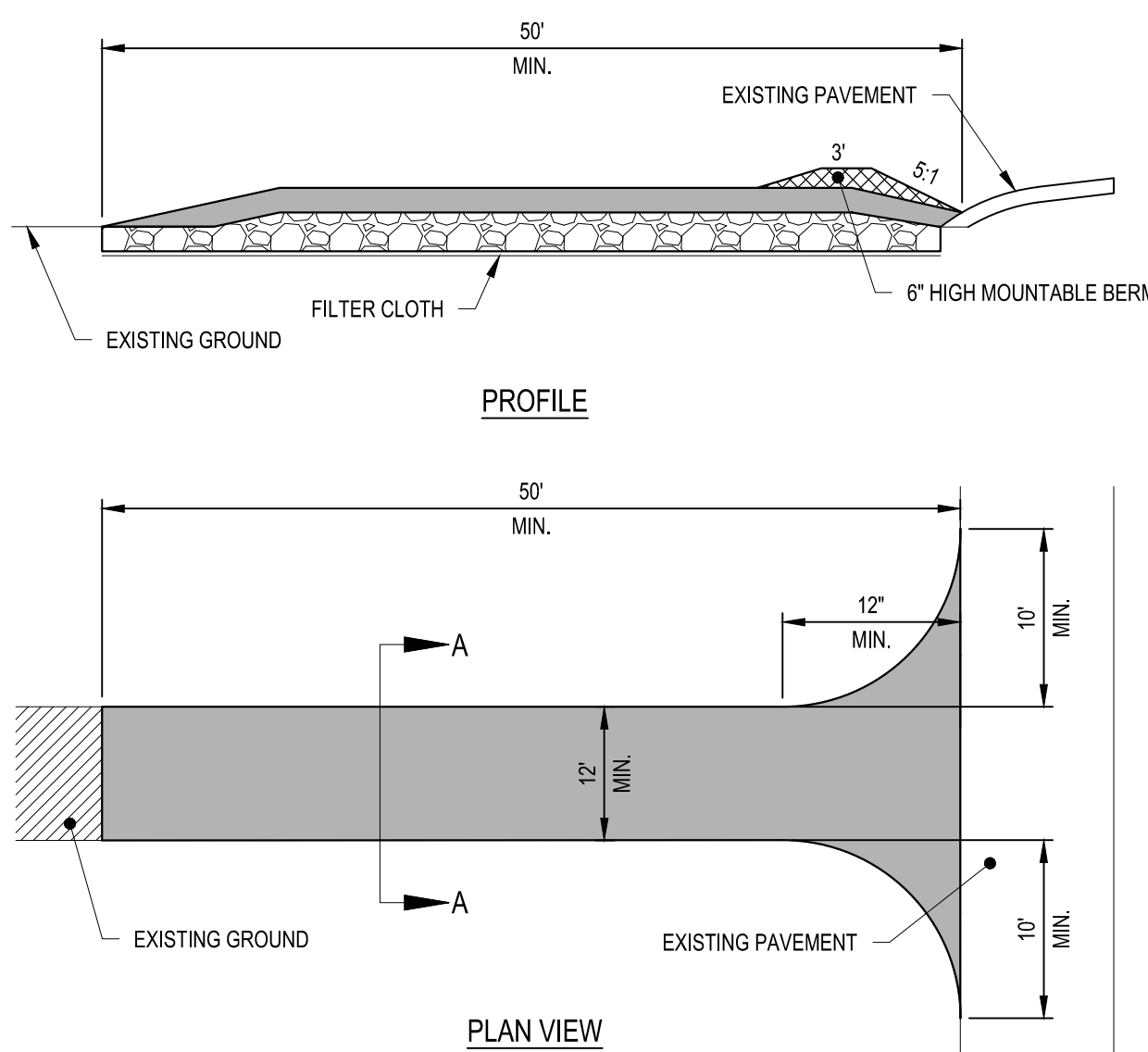

- STABILIZED CONSTRUCTION ENTRANCE NOTES:**
- WIDTH - TWELVE (12) FOOT MINIMUM, BUT NOT LESS THAN THE FULL WIDTH AT POINTS WHERE INGRESS OR EGRESS OCCURS. TWENTY-FOUR (24) FOOT IF DUAL DIRECTION ENTRANCE / EXIT TO SITE.
 - FILTER CLOTH - WILL BE PLACED OVER THE ENTIRE AREA PRIOR TO PLACING OF STONE.
 - SURFACE WATER - ALL SURFACE WATER FLOWING OR DIVERTED TOWARD CONSTRUCTION ENTRANCES SHALL BE PIPED ACROSS THE ENTRANCE AS DIRECTED BY THE ENGINEER. IF PIPING IS IMPRACTICAL, A MOUNTABLE BERM WITH 5:1 SLOPES WILL BE PERMITTED.
 - MAINTENANCE - THE ENTRANCE SHALL BE MAINTAINED IN A CONDITION WHICH WILL PREVENT TRACKING OR FLOWING OF SEDIMENT ONTO PUBLIC RIGHTS-OF-WAY. ALL SEDIMENT SPILLED, DROPPED, WASHED OR TRACKED ONTO PUBLIC-RIGHTS-OF-WAY MUST BE REMOVED IMMEDIATELY.
 - WHEN WASHING IS REQUIRED, IT SHALL BE DONE ON AN AREA STABILIZED WITH STONE AND WHICH DRAINS INTO AN APPROVED SEDIMENT TRAPPING DEVICE.
 - PERIODIC INSPECTION AND NEEDED MAINTENANCE SHALL BE PROVIDED AFTER EACH RAIN.
 - THE STABILIZED CONSTRUCTION ENTRANCE SHALL BE REMOVED UPON SITE STABILIZATION AND RESTORED TO EXISTING CONDITION UNLESS ORDERED TO REMAIN BY ENGINEER.
 - ALL MATERIALS REQUIRED FOR THIS ITEM SHALL BE PAID FOR UNDER ITEM C-102 BY THE UNIT COST PER EACH FOR STABILIZED CONSTRUCTION ENTRANCE.

C1 WORK AREA COORDINATE TABLE
SCALE: NOT TO SCALE

C3 STABILIZED CONSTRUCTION ENTRANCE DETAIL
SCALE: NOT TO SCALE

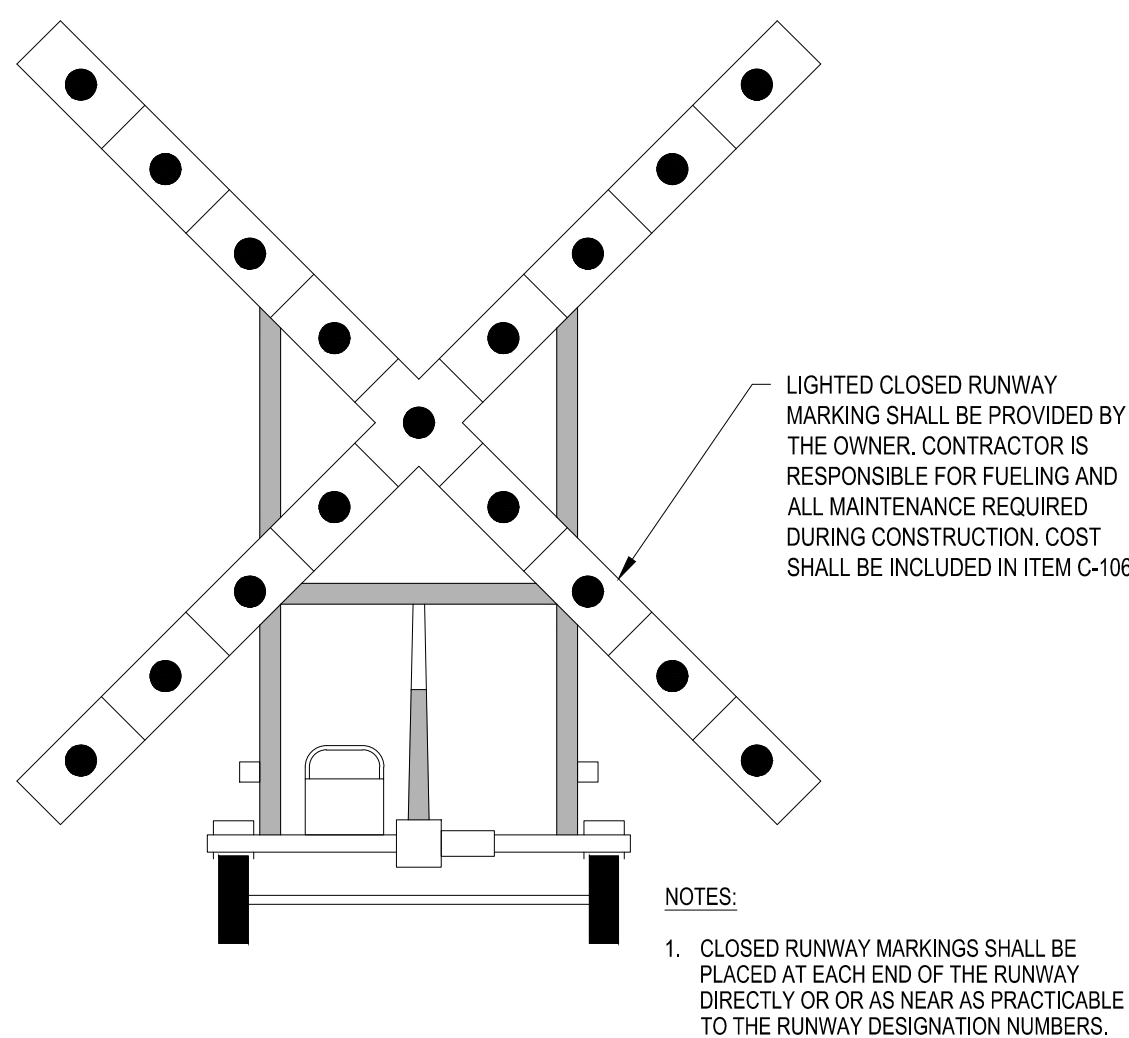

B1 LIGHTED CLOSED RUNWAY MARKING DETAIL
SCALE: NOT TO SCALE

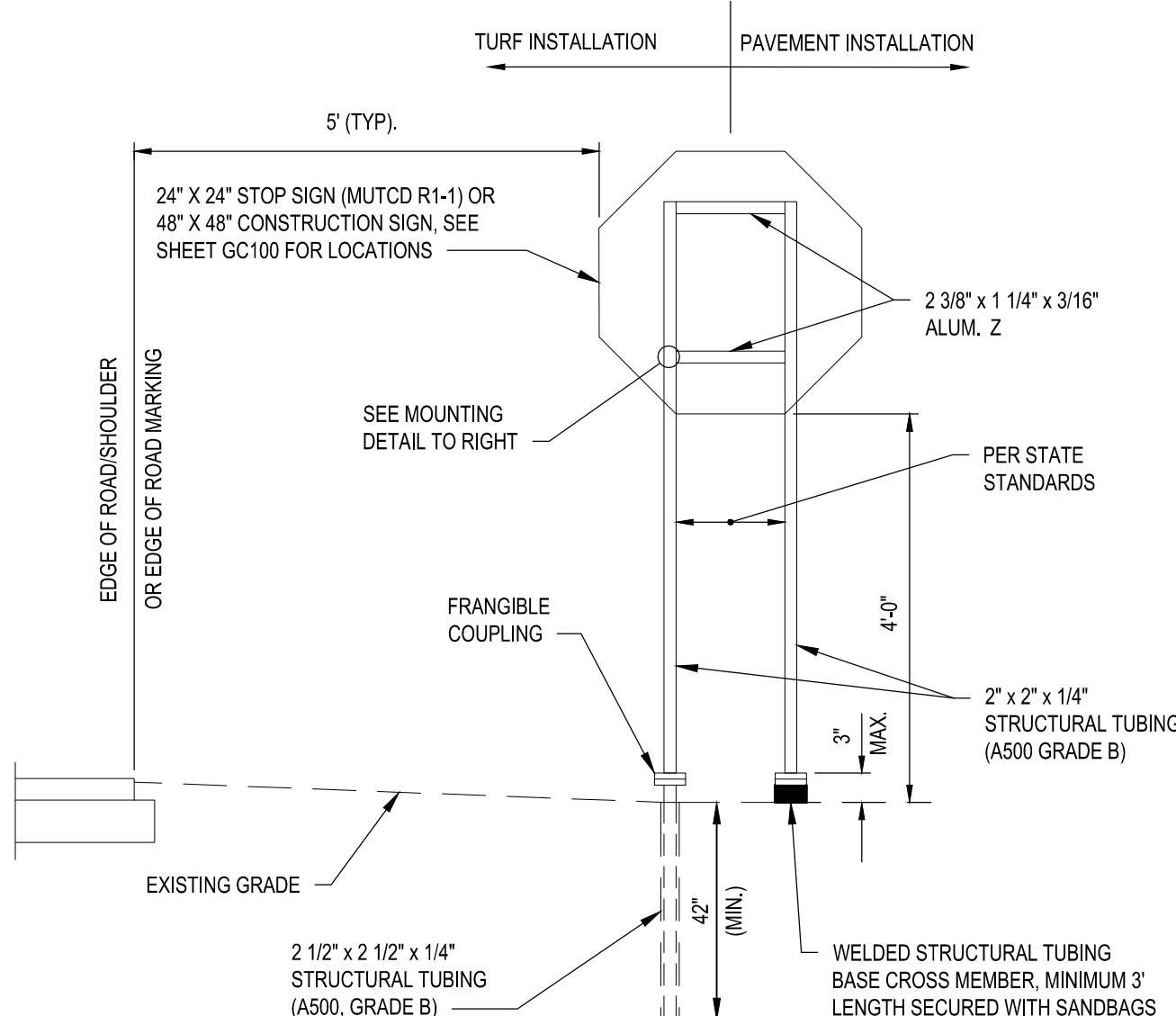

B2 TEMPORARY CONSTRUCTION SIGN ASSEMBLY DETAIL
SCALE: NOT TO SCALE

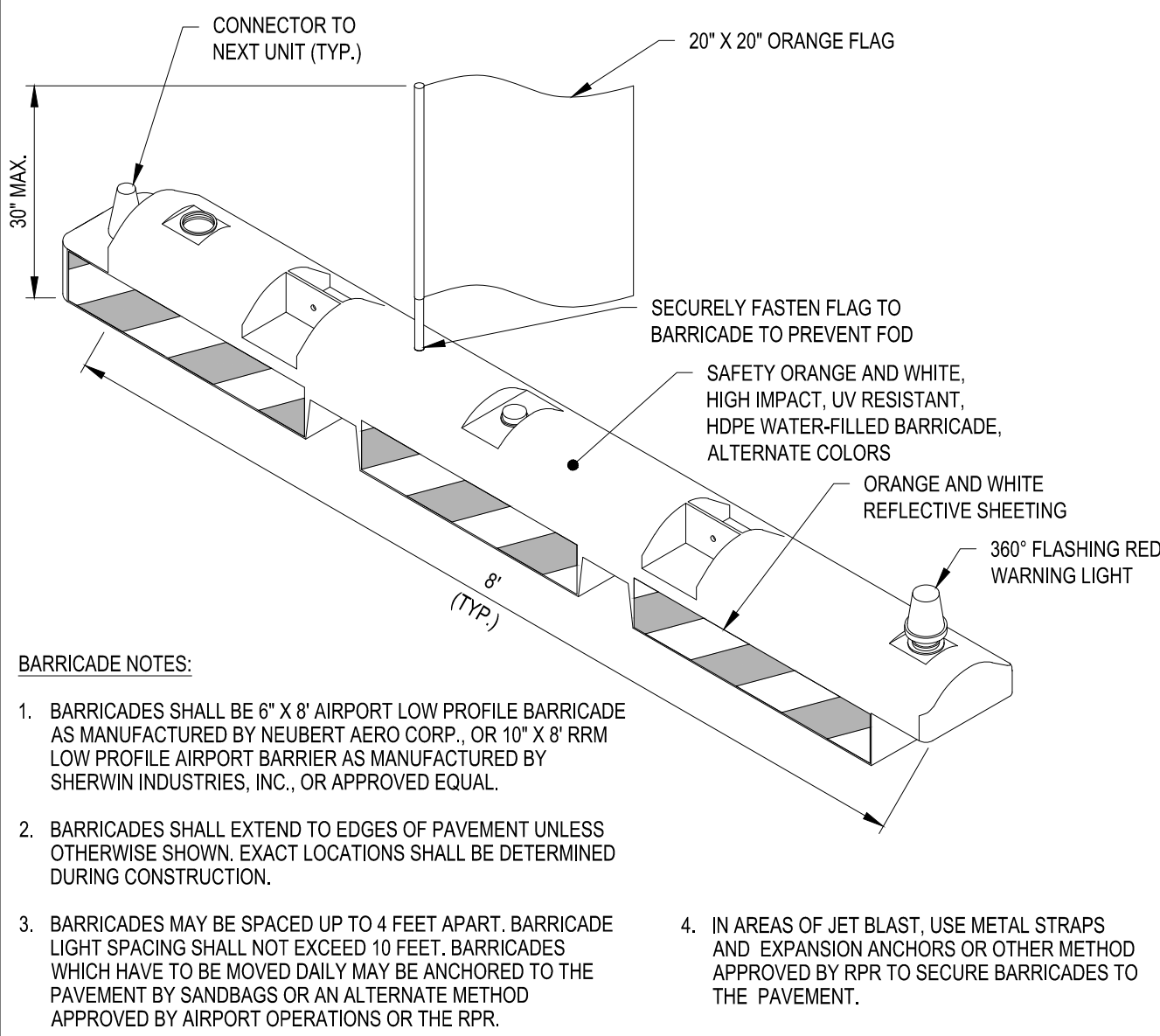

A1 INTERLOCKING AIRFIELD BARRICADE DETAIL
SCALE: NOT TO SCALE

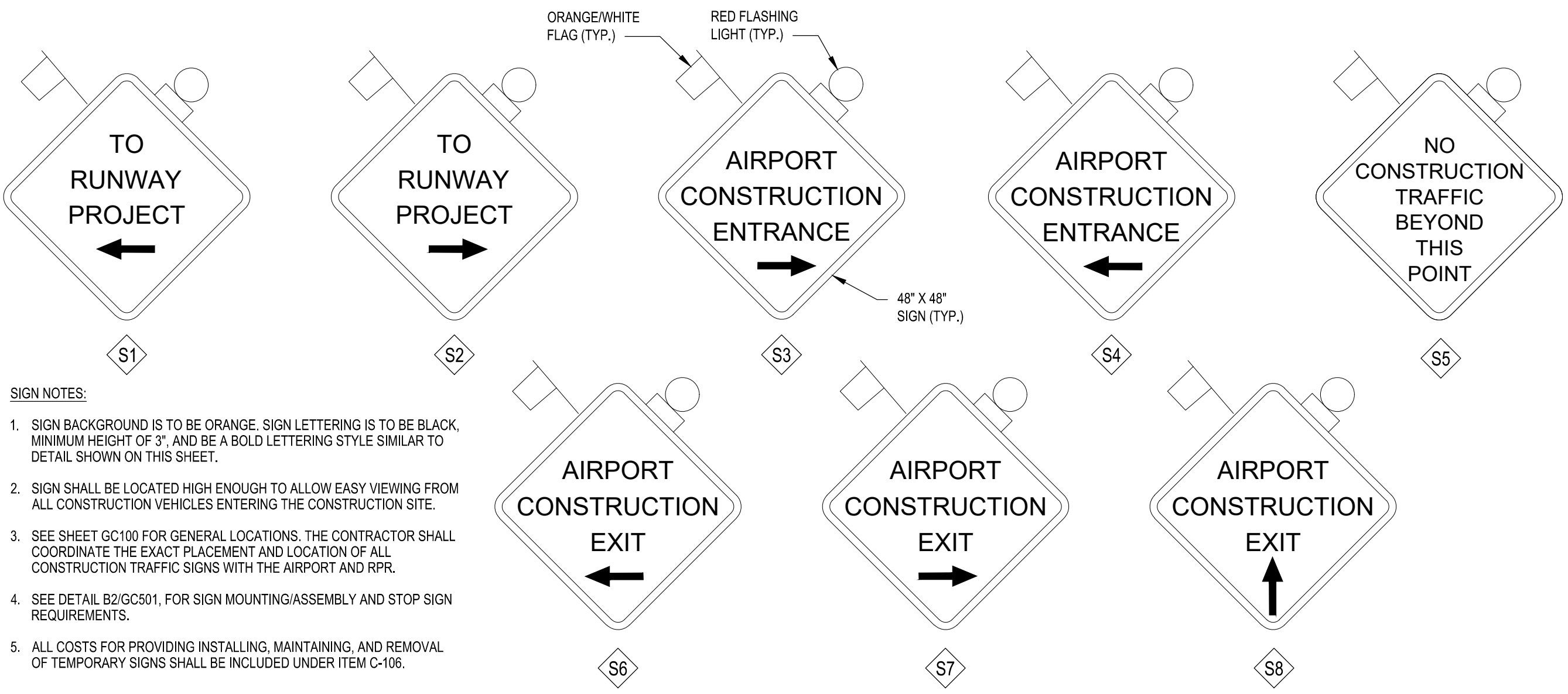

A2 TEMPORARY CONSTRUCTION SIGN DETAIL
SCALE: NOT TO SCALE



C&S Engineers, Inc.
41 State Street, Suite 600
Albany, New York 12207
Phone: 518-915-7349
www.cscos.com



RUNWAY 01-19 REHABILITATION AND LIGHTING UPGRADES
ALBANY INTERNATIONAL AIRPORT COLONIE, NEW YORK

MARK	DATE	DESCRIPTION
REVISIONS		
PROJECT NO: Q23014001		
DATE: FEBRUARY 2024		
DRAWN BY: M.D. HERNANDEZ		
DESIGNED BY: R.J. KOLLER		
CHECKED BY: C.D. BRUBACH		

CONSTRUCTION SAFETY AND PHASING DETAILS

GC501

AGENDA ITEM NO. 13

Informational Only

Old Business

New Business

Executive Session
Attorney-Client Privilege Matters

