



ALBANY COUNTY AIRPORT AUTHORITY
 ALBANY INTERNATIONAL AIRPORT
 ADMINISTRATION BUILDING
 SUITE 200
 ALBANY, NEW YORK 12211-1057

TEL: 518-242-2222
 ADMIN FAX: 518-242-2641
 FINANCE FAX: 518-242-2640
 SITE: www.albanyairport.com

Minutes of the Regular Telephonic Meeting of the Albany County Airport Authority

June 8, 2020

**ACAA Approved
 07-20-2020**

Pursuant to notice duly given and posted, the regular telephonic meeting of the Albany County Airport Authority was called to order on Monday, June 8, 2020 at 11:30 a.m. via telephonic by Chairman Kenneth J. Doyle with the following present:

MEMBERS PRESENT

Rev. Kenneth J. Doyle
 Tony Gorman
 Lyon M. Greenberg, M.D.
 Steven H. Heider (via telephone)
 Kevin R. Hicks
 Samuel A. Fresina
 Sari M. O'Connor

MEMBERS ABSENT

STAFF

Philip F. Calderone, Esq.
 Michael F. Zonsius
 Liz Charland
 Steve Iachetta
 John LaClair
 Helen Chadderdon (via telephone)
 Margaret Herrmann (via telephone)
 Kathy Greenwood (via telephone)
 Matt Cannon (via telephone)
 Chris Quinn (via telephone)

ATTENDEES

Fred Acunto, Airport Manager, AvPorts (via telephone)
 John DelBalso, Assistant Airport Manager, AvPorts (via telephone)
 Dennis Feeney, Majority Leader (via telephone)
 Bob Heitz, Million Air (via telephone)
 Eric Anderson, Times Union (via telephone)
 Ray Casey, Airport Consultant (via telephone)
 John O'Donnell, Airport Consultant (via telephone)

General:

1. Chairman's Remarks

2. Approval of Minutes

Mr. Hicks moved to approve the minutes of the April 6, 2020 regular meeting.

The motion was adopted unanimously.

3. Communications and Report of Chief Executive Officer

Mr. Calderone presented the Communications and Report of the Chief Executive Officer for the month of June 2020

4. Interesting Correspondence

Management Reports:

5. Chief Financial Officer

Mr. Zonsius presented the Financial Report for the month of June 2020

6. Project Development

Mr. LaClair presented the Project Development Report for the month of June 2020.

7. Counsel

8. Concessions/Ambassador Program Month of June 2020

9. Public Affairs Month of June 2020

Action Items:

10. Authorization of Contracts/Leases/Contract Negotiations/Contract Amendments

10.1 Construction Contract: Authorization to Award Construction Contract 1039-GC Passenger Boarding Bridge Improvements to AERO Bridgeworks, Inc.

Mr. Iachetta recommended authorization to award Contract 1039-GC for Passenger Boarding Bridge Improvements to qualified low bidder AERO Bridgeworks, Inc. in the amount of \$2,520,000. The contract scope includes replacement of existing passenger boarding bridges A-3, A-5, B-10 & C-1 and the removal of the Over-the-Wing bridges at gates C-2 & C-3. The existing passenger boarding bridges are over 20 years old and the maintenance costs to keep them operational increases annually. The new bridge installation will include removal of the existing unit and installation of a newly fabricated unit at each location. Award contingent upon FAA concurrence and compliance with Apprenticeship Program. He advised this contract will be funded

from CPN account number 2251 and will be 90% Federally funded and 10% CARES Act funded.

Mr. Fresina moved to authorize Contract 1039-GC for Passenger Boarding Bridge Improvements to AERO Bridgeworks, Inc. to AERO Bridgeworks, Inc. to AERO Bridgeworks, Inc. in the amount of \$2,520,000 contingent upon FAA concurrence and compliance with the Apprenticeship Program. The motion was adopted unanimously.

10.2 Construction Contract: Authorization to Award Construction Contract 1039-E Passenger Boarding Bridge Improvements to AERO Bridgeworks, Inc.

Mr. Iachetta recommended authorization to award Contract 1039-E for Passenger Boarding Bridge Improvements to qualified low bidder AERO Bridgeworks, Inc. in the amount of \$694,000. The contract scope includes all electrical removal and replacement of electrical equipment for passenger boarding bridges A-3, A-5, B-10 & C-1 and the removal of the Over the Wing (OTW) bridges at gates C-2 & C-3. The existing passenger boarding bridges are over 20 years old and the maintenance costs to keep them operational increases annually. New bridge installation will include removal of the existing unit and installation of a newly fabricated unit at each location. The award is contingent upon FAA concurrence and compliance with Apprenticeship Program. He also advised this contract will be funded from CPN account number 2251 and will be 90% Federally funded and 10% CARES Act funded.

Mr. Fresina moved to authorize Contract 1039-E for Passenger Boarding Bridge Improvements to AERO Bridgeworks, Inc. in the amount of \$694,000 contingent upon FAA concurrence and compliance with the Apprenticeship Program. The motion was adopted unanimously.

10.3 Construction Contract: Authorization to Award Construction Contract 1009-PAV Long Term and Employee Parking Lot Paving to New Castle Paving

Mr. LaClair recommended authorization to award Contract 1009-PAV Long Term and Employee Parking Lot Paving to New Castle Paving in the amount of \$195,892. The contract scope includes removal (milling) of 2" of the existing pavement, cleaning and tack coating of the surface and paving the areas with 2" of Hot Mix Asphalt. The award of this contract is contingent on compliance with the M/WBE requirements.

In addition, each successful contractor and subcontractor utilized by the successful bidder, which are performing work shall have an apprenticeship agreement appropriate for the type and scope of work performed in all trades that has been registered with and approved by the NS Commissioner of Labor. The award of this contract is contingent on compliance with the M/WBE requirements. This contract will be funded from CPN account number 2261 and will be 100% airport funded.

Dr. Greenberg moved to authorize Contract 1009-PAV for the long term and employee parking lot paving to New Castle Paving in the amount of \$195,892 contingent upon compliance with M/WBE requirements. In addition, each successful contractor and subcontractor utilized by the successful bidder, which are performing work shall have an apprenticeship agreement appropriate for the type and scope of work performed in all trades that has been registered with and approved by the NS Commissioner of Labor. The motion was adopted unanimously.

10.4 Professional Services: Authorization to Award Contract S-1042 with CHA Consulting, Inc. for Preparation of the Airport Master Plan

Mr. Iachetta requested authorization to award professional engineering service Contract S-1042 with CHA Consulting, Inc. in the amount of \$749,965. Authorization to negotiate with CHA Consulting, Inc. was authorized at the May 4 ACAA Board meeting. He advised the last full FAA Airport Master Plan was completed in 1979 with a comprehensive Airport Layout Plan Update completed in 1998 by CHA to support Terminal and Air Cargo Improvements completed in 2002. Award will be contingent on satisfaction of Federal DBE program compliance, FAA Contract Concurrence and AIP grant issuance. Funding is programmed with FAA as AIP Entitlement grant #3-36-0001-141-2020 This contract will be funded from CPN account number 2290 and will be 90% Federally funded and 10% CARES Act funded.

Mr. Hicks moved to authorize Contract S-1042 with CHA Consulting, Inc. for Preparation of the Airport Master Plan in the amount of \$749,965 contingent on satisfaction of Federal DEB program compliance. The motion was approved unanimously.

11.1 Change Order #7: Authorization to award Change Order #7 (credit) to Contract # 989-SF New Parking Garage Site and Foundations to LeChase Construction Services, LLC.

Mr. LaClair recommended authorization of Change Order #7 for Contract 989-SF for New Parking Garage Site and Foundations, to LeChase Construction Services LLC in the credit amount of (-\$162,000.00). This item is a credit for the depressurization well which was never completed by the contractor in accordance with the plans and specifications.

Dr. Greenberg moved to authorize Change Order No. 7 for Contract No. 989-SF for the New Parking Garage General Construction to LeChase Construction Services, LLC in the credit amount of (-\$162,000.00). The motion was adopted unanimously.

11.2 Change Order #8: Authorization to award Change Order #8 to Contract # 989-GCr New Parking Garage (Gateway Sign) General Construction to LeChase Construction Services, LLC

Mr. LaClair recommended authorization of Change Order #8 for Contract 989-GCr for the New Parking Garage General Construction to LeChase Construction Services LLC in the amount of \$200,000.00 the contract incentive for early completion. The Contractor completed this project 20 days ahead of schedule, per the incentive \$10,000.00 a day to a maximum of \$200,000.00.

Mr. Hicks moved to authorize Change Order No. 8 or Contract 989-GCr for the New Parking Garage General Construction to LeChase Construction Services LLC in the amount of \$200,000.00 the contract incentive for early completion. The motion was adopted unanimously

12. Authorize CEO to Issue Safety Directives to Ground Transportation Providers at the Airport Due to Covid-19

Mr. Calderone requested to adopt the Special Rule below so that the CEO can issue safety directives to ground transportation companies in the quickly changing environment relative to Covid-19.

SPECIAL RULE RELATED TO GROUND TRANSPORTATION SAFETY
DIRECTIVES
Due to COVID-19

Due to the Covid-19 health epidemic, the Albany County Airport Authority hereby authorizes its Chief Executive Officer to issue directives relative to the operation of ground transportation businesses (Taxicabs, Transportation Network Companies, shuttles and limousines) at the Airport to ensure safety. These directives may include, but not be limited to the wearing of personal protection equipment by vehicle operators and passengers, limitation on shared rides and numbers of passengers, and disinfection of vehicles.

Father Doyle moved to authorize CEO to Issue Safety Directives to Ground Transportation Providers at the Airport Due to Covid-19 and adopt the Special Rule below so that the CEO can issue safety directives to ground transportation companies in the quickly changing environment relative to Covid-19.

SPECIAL RULE RELATED TO GROUND TRANSPORTATION SAFETY
DIRECTIVES
Due to COVID-19

Due to the Covid-19 health epidemic, the Albany County Airport Authority hereby authorizes its Chief Executive Officer to issue directives relative to the operation of ground transportation businesses (Taxicabs, Transportation Network Companies, shuttles and limousines) at the Airport to ensure safety. These directives may include, but not be limited to the wearing of personal protection equipment by vehicle operators and passengers, limitation on shared rides and numbers of passengers, and disinfection of vehicles. The motion was adopted unanimously.

13. Authorization of Federal and State Grants

13.1 Acceptance of Federal Airport Improvement Program Grant No. 3-36-0001-141 2020; Prepare Airport Master Plan

Mr. Iachetta recommended Acceptance of Federal Airport Improvement Grant No. **3-36-0001-141 2020; Prepare Airport Master Plan** as follows in the amount of \$676,039 Federal Share 90% and Federal CARES Act \$75,116.00 for a total of \$751,155.0.

Mr. Fresina moved to authorize the Acceptance of Federal Airport Improvement Grant No. **3-36-0001-141 2020; Prepare Airport Master Plan** as follows in the amount of \$676,039 Federal Share 90% and Federal CARES Act 10% \$75,116 for a total of \$751,155.00. The motion was adopted unanimously.

13.2 Federal/State Grant: Acceptance of Federal Airport Improvement Program Grant #3-36-0001-142-2020; Replace Boarding Bridges A3, A5, B10, and C1; Remove OTW Bridge C2 and C3; Design and Construction; Phase 4 of 6

Mr. Iachetta recommended Acceptance of Federal Airport Improvement Grant No. 3-36-

0001-142-2020; Replace Boarding Bridges A3, A5, B10, and C1; Remove OTW Bridge C2 and C3; Design and Construction; Phase 4 of 6 in the amount of \$3,140,730 Federal Share 90% and Federal CARES Act 10% \$348,970 for a total of \$3,489,700 to support Contracts S-1039; 1039-GC and 1039-E

Ms. O'Connor moved to authorize the Acceptance of Federal Airport Improvement Grant No. 3-36-0001-142-2020; Replace Boarding Bridges A3, A5, B10, and C1; Remove OTW Bridge C2 and C3; Design and Construction; Phase 4 of 6 in the amount of \$3,140,730 Federal Share 90% and Federal CARES Act 10% \$348,970 for a total of \$3,489,700. The motion was adopted unanimously.

Old Business: None

New Business: None

Executive Session: Attorney-Client Privilege Matters:

Mr. Gorman made a motion to go into Executive Session to discuss two matters of Attorney-Client Privilege:

ES-1 – Employment history of a particular individual.

ES-2 – Employment history of a particular individual.

Dr. Greenberg moved to go out of Executive Session. The motion was adopted unanimously.

There was no action taken on either of the Executive Session items.

There being no further business, the meeting was adjourned at 12:30 p.m.

ALBANY COUNTY AIRPORT AUTHORITY

REGULAR MEETING

AGENDA

June 8, 2020

General:

- 3. Chairman's Remarks**
- 4. Approval of Minutes**
Regular Meeting – April 6, 2020
- 4. Communications and Report of Chief Executive Officer**
- 4. Interesting Correspondence**

Management Reports:

- 5. Chief Financial Officer**
- 6. Project Development**
- 7. Counsel**
- 8. Concessions/Ambassador Program (Refer to report.)**
- 9. Public Affairs (Refer to report.)**

Action Items:

- 10. Authorization of Contracts/Leases/Contract Negotiations/Contract Amendments**
 - 10.1 Construction Contract: Authorization to Award Construction Contract 1039-GC Passenger Boarding Bridge Improvements to AERO Bridgeworks, Inc.**
 - 10.2 Construction Contract: Authorization to Award Construction Contract 1039-E Passenger Boarding Bridge Improvements to AERO Bridgeworks, Inc.**
 - 10.3 Construction Contract: Authorization to Award Construction Contract 1009-PAV Long Term and Employee Parking Lot Paving to New Castle Paving**
 - 10.4 Professional Services: Authorization to Award Contract S-1042 with CHA Consulting, Inc. for Preparation of the Airport Master Plan**

11. **Authorization of Change Orders**
 - 11.1 **Change Order #7: Authorization to award Change Order #7 (credit) to Contract # 989-SF New Parking Garage Site and Foundations to LeChase Construction Services, LLC.**
 - 11.2 **Change Order #8: Authorization to award Change Order #8 to Contract # 989-GCr New Parking Garage (Gateway Sign) General Construction to LeChase Construction Services, LLC**
12. **Authorize CEO to Issue Safety Directives to Ground Transportation Providers at the Airport Due to Covid-19**
13. **Authorization of Federal and State Grants**
 - 13.1 **Acceptance of Federal Airport Improvement Program Grant No. 3-36-0001-141 2020; Prepare Airport Master Plan**
 - 13.2 **Federal/State Grant: Acceptance of Federal Airport Improvement Program Grant #3-36-0001-142-2020; Replace Boarding Bridge A3, A5, B10, and C1; Remove OTW Bridge C2 and C3; Design and Construction; Phase 4 of 6**

Old Business:

New Business:

Executive Session - Attorney-Client Privilege Matters:

Add On:

ES-1 – Employment history of a particular individual.

ES-2 – Employment history of a particular individual.

ACAA

Moderator: Liz Charland
June 8, 2020
11:21 a.m.

Man 1: All right. It's 11:30 so we're going to call the meeting to order. And thanks, for everybody who is here and everybody who is online. It's nice to see faces again. The first order of business is to approve the minutes from our last meeting which was April 6th. Any additions or changes to those minutes? If not, I'll take a motion to approve. (Kevin Hicks). Second, (Sari). All of those in favor?

Man: Aye.

Man: Aye.

Man 1: The minutes are approved. Phil Calderone will give us a report now.

Phil Calderone: I'm going to echo (Father)'s comments about it's nice to see faces and everyone - having everyone in the room again. And we're - welcome to everyone who is listening in remotely. I thought what I would begin doing is just take us through since we're, you know, moving into hopefully a new phase, the reopening phase for our state. I'll take us back through a little bit of where we were in February and what the airport did in response to the

Coronavirus pandemic crisis.

Beginning in February, we - reading about what was happening throughout the world and other locations, particularly in China and Europe, we began taking steps here proactively at Albany International, by convening a Coronavirus taskforce. The members of the task force grew over time to include (unintelligible) center. But Dr. (Greenberg) has been there from the beginning along with representatives from the Sheriff's Department and from Air Traffic Control and TSA, Homeland Security and our own fire department (unintelligible) and authority of staff.

And with that task force, we began reviewing and implementing plans that we had already had in place here at the Authority, including our disaster preparedness plan, the pandemic preparedness plans which were very well done. But we did tweak them a bit and we for example, worked with Air Traffic Control to work on a remote plan should there be a need to close down this - our operation. That was something that was not in the pandemic preparedness plan and it's something that we did early on that helped us in a way I think that avoided problems with other airports.

We also were fortunate that we had (Cyber WA) on retainer. We brought them in after we had the ransomware attack. And they were in the process of meeting with all of the different operation centers here at the airport, accepting and putting together a plan for critical needs at the airport should there be any kind of a disaster. And we worked with (Cyber WA) to refine that plan to tailor it to specific needs for remote working in the event that that's the single possibility. And of course, that is exactly what happened.

Moving into thinking of March through April, we saw a dramatic change in - as did the world, in the way operations took place here. We went from having

nearly 4000 folks going through the TSA checkpoints to having nearly - by the end of April, a 97% reduction in folks going through the checkpoint. And that required us to begin early in March, doing some things to assure passengers that we were doing everything possible to protect their safety.

It began with simple things in the beginning like installation of hand sanitizers and the distribution of our now infinite bottles of hand lotion. But it again became a much more involved protocol. We followed CDC guidelines, we purchased high intensity cleaning sprayers. We began a protocol of disinfecting all surfaces in the terminal. We purchased touchless timekeeping systems to protect our employees, we began working with the employees' unions to share with the airlines, the concessions, and the media, to get the message out of what is happening at the airport and what the steps were that we were taking to ensure the traveling public that we at the airport were ready for travel to be as safe as possible.

We also looked at our financial situation because with a 97% reduction in folks at the checkpoint obviously our passenger facility charges, our parking fee revenue and landing weight charges from the airlines were being impacted in significant ways on the revenue side. So we began looking at the expense side to see how we could limit expenditures, toe the line on discretionary spending, limit capital expenditures where possible and working with the unions very successfully, to repurpose employees so that money that we would have spent on outside contractors, we repurposed employees to do that kind of work so that we were able to avoid furloughing or laying off employees.

We also closed the below parking areas, we closed the parking garages, we ended shuttle and valet services all in an effort to save money on the expense side. We also were faced with the governor to approve executive orders to try

to make the state stay safe. Those orders included (CS40). We were part of the state workforce that was ordered to reduce our nonessential workforce, (ICE), risk employees here at the (surety) by as much as 50%. We did that.

And as I mentioned earlier, because of the work that had been done by (Cyber WA), (ES) and our own IT department, we were able to set up employees so that they were able to work remotely. We began having daily call-ins with all of our employees every morning, routinely both to keep track of work that was going on and also to keep morale up.

In February we had a lot of work going on here at the Authority as (John LaClair)'s filing will attest to. At that point of February we were literally meeting every single day, with different groups of contractors and subcontractors as well as our general construction manager, Turner, on the status of different aspects of the airport that were under construction. Work in the terminal, work, you know, in the new parking garage and we had a deadline, if you'll recall, a deadline of March 31 which we were very successfully moving toward and which we did accomplish.

But during that time period the governor's executive order also included shutting down all non-essential work. We made determinations of projects that were going to be put on hold and we gave the move forward and met our deadline of completing the essential projects by March - that deadline of March 31st. But it also required us to coordinate safety protocols with all of the construction workers here working in the terminal or in the garage.

And thanks (John) and Turner for ensuring the safety of all the workers who were coming into the airport, to complete those construction projects. Simultaneously, we were at this point, realizing that the world of aviation was in the disaster mode and we began working with our colleagues and our

lobbying groups through AAAP and New York Association of Airline Executives, to lobby for CARES Act funding. Our folks here at the Authority, made direct contact with our Congressional leaders and with Senator Schumer's office in particular.

Airports were not included in the first CARES Act round of funding, the first draft of the bill. We pushed hard to explain that if we weren't successful the beer and wine industry was not going to be successful in a recovery. We were able successfully, to make our case and happily \$10 billion in CARES Act funding was included for airports and our share of it was a significant amount of money, over \$15 million which we'll get more to in a minute.

We also began working on enhancing at the same time, the importance of airports to the economy and impressing on folks the work that we were doing. And I did in that regard, a number of outreach opportunities, some provided by the County Executive, others provided by local media, to tell our story of what we were doing and our importance to the region. Once we did receive notice that the CARES Act funding had been approved and the \$15 million plus to our airport, we began the process of obtaining FAA approval to use that CARES Act money to begin paying payroll and debt service at the airport.

It's critical to us. It's my goal. We'll talk about it to ensure that we have adequate revenue and have adequate revenue to meet our bond covenant. And that's why we structured our CARES Act funding as we have. And FAA was very pleased with our proposal and I'm happy to say that we've already received over - we received two installments of CARES Act funding already. And I'm hopeful that the remainder of the CARES Act funding we'll come in so the rest of you will carry up through without having to dip into reserves if we continue to be prudent.

At the same time that we were working on CARES Act funding, we were again focused on getting our message out to the public and letting the public know, both public coming into the terminal as well as general traveling public, the steps that we were taking here at the airport to protect those coming into the terminal. And we began putting into place requirements that folks coming here are needing to wear. And we did this earlier than I think most other airports throughout the country.

Wear face masks in not only the terminal but all airport buildings. We began working with all of the businesses here at the airport and there are many including all of the concessionaires, to put into place the governor's return to work plans that are required to be in place before businesses can reopen. We also began installing throughout the terminal, things like the social distancing footprint that you see. We work with TSA on cleaning protocols, we work with the airlines, TSA and concessionaires on installing Plexiglas shields at all contact point interactions with the public, to protect both the workers and the public.

We purchased and have installed UV lighting treatments for the handrails on the escalators. We installed high filtration screens on all air handlers in the terminal, as well as increased air flow in the terminals to create better circulation and better purification of the air. Again, I mentioned the touchless time clock. We are now going to be working with ground transportation at the airport and I'll talk more about that later on in the meeting, to ensure that those coming to the airport can pick folks up, packaged as Uber, Lyft or shuttle buses will have sanitation protocols in place.

We're beginning to explore new touchless - we're continuing to (explore) new touchless technology. And in that regard, we're working with critical partners

who reached out to GE Research and Development, through (RPI), and to (AC)'s Pleasant Valley Community College, to help us in this regard. I'm thrilled that Dr. (Jackson) has assigned two of her top (unintelligible) to work with us. And we will be able to discuss exploring the partnership and ways they can work with us.

Our relationship with GE has been very, very productive. Dr. (Nelson) who is one of their top scientists, he's actually working on one of the critical Coronavirus vaccines, has volunteered to be a resource to us to review new touchless technologies that we've already asked his opinion on. And so we're very fortunate to have some very high level, high caliber folks working with us as we move forward. Preparing for the recovery we're working on our master plan and that's inflating opportunity. We'll be talking about that also later on in the meeting.

It's going to be an opportunity for us to again tell the public about the exciting plans we have here in the future, in the very near future hopefully, as we begin to grow and expand our footprint as an economic development driver for the region. And in that regard, we have a number of projects that we're seeking approval from the AIA for capital projects going forward in the future. And we're working with the airlines on renewing our use and lease agreements with them.

We had a very productive meeting at the end of last week with both Southwest and American. And we're sending that - (Michael) and I, a letter summarizing that meeting. So hopefully if they are in agreement, we will bring back a proposal to the board at the next meeting of the board. And we are continuing to work with the airlines, with TSA and all of our partners, to instill confidence that the airline industry is back and ready and will rebound.

In March I see that just this morning we were down by 97% as I mentioned earlier, by the end of March, the beginning of April. This past Tuesday we had 543 folks through the TSA turnstile and on Friday we did 1000 again. Going into - the younger generation will not remember this movie, but there's a movie Being There with Chance the gardener, it's a Peter Sellers movie. It's an allegorical film, one of my favorites. And this is a line from Chance the gardener. Growth has its seasons. First, comes spring and summer. We've been through a tough spring and summer, we probably will have a challenging fall and winter as well.

But we're going to have a new spring and we're going to have a new summer and we'll be back. The country will be back. Our airport will be back and we're ready. So that's my presentation. And I included this photo, I wish those on the line could see it. It's a photo of a number of (hosta) flowers that you might see around the airport. One of the things that I did do, we had an opening that asked for a gardener. I enticed the former city gardener, (Judy Stacy). Many of you might remember her. She's an award-winning gardener and extraordinary woman.

She used to fly to Holland and pick out the tulip bulbs herself that she would plant for the city. I enticed her to be our gardener at Albany International. So I expect great things for the airport to be blooming again, literally and figuratively. So thank you everyone.

Man: Well, thanks, Phil. I - you never dreamed when you took this job that you'd have to learn so much all at once because of the circumstances. But you've kept on top of it all and we're (unintelligible). Any questions for (Phil)?

Man: (Unintelligible) of bringing in the medical aspect to things and (technical) on top of (unintelligible). And just the implication is (unintelligible). And we

were aware and we were thinking about - Phil was thinking about things long before the (unintelligible).

Man: Terrific. Terrific. Next, Michael Zonsius. You may not recognize him with the haircut.

Michael Zonsius: Thank you, (unintelligible). Interesting times but we're really getting better and we're passionate with (unintelligible) we're going to be okay. This is where we work. This is (unintelligible) and as we continue we have to (unintelligible) going back, you know, to April we were about 300,000 (unintelligible). Well over the next, you know, eight months, May through December, we expect probably around another 300,000 (unintelligible). The reason is, is what we've seen from Fitch, you know, the rating agency (unintelligible) they came out with what the projections are.

I mean correct (unintelligible) gap but they're pretty solid here and it's what we're going with. And after discussions with Phil, we decided on what (unintelligible). The imaging that we were (unintelligible) for this year we were (unintelligible) down 40%, next year 80%, the year after '22, is 84%, the year 2023 86% and thereafter 2024, we'll be up 102%. And that's 102% of what we did in 2019. Although we had 1.48 million passengers, so round it out I use 1.5 million. So what you can see here in the dark purple (unintelligible) color, that's where we are and that we're right here.

And then this green line is what we project for the next eight months. Again, January through April, 293,000 passengers, call it 300,000. So that's what we're projecting for the end of the year, 600,000 passengers. And (unintelligible) running 12-month average, and I use 12-months of running average, just to take the variability out of the (graph). We continue - by giving it would look like a (unintelligible) make sense. But this is where we are right

now. And as we go through the next two months probably down here will be in December.

And then this is the recovery period here. And so then in 2021 we're up 80%, in 2022, 84%, in 2023 I think I said 86% not 88%. And then full recovery by November of 2024. I did want to mention this light green line right here, that's what we project out in 2021. This is- now this is interesting for me. This is the throughput from TSA and the throughput at the airport.

Throughput is the number of people that are going through the - standing at the terminal. Keep in mind some of those people are employees and they're including in those (unintelligible) in material amounts. This is where we were in March and how it came down. This (unintelligible) a weekly basis because every day there's a different number of flights scattered into (unintelligible) Monday through Thursday.

So again, by doing it on a seven-day running average and taking out the (unintelligible) this was (unintelligible). And it looked kind of bleak. I mean it was kind of flat but I'm very hopeful these past few days, Friday, Saturday, Sunday, they came up. You know, 453,000 people go through - nationwide for throughput. So that reached the largest we had and that was yesterday. And in case I didn't mention and I forgot, the blue is the national average or the national amount, the red is the (unintelligible) Albany International Airport.

I've been on sites for (unintelligible) a lot and I should say, you know, pretty much 50% of what the load factor is. So our people flying came in last night. We had people coming off of American, United and Southwest and we're really excited. Oh. I also put the screen back here. And gain, this is where we were at December, around 12,000 passengers per week. That will give us the 600,000 threshold that we are modeling again.

This is the revenues (unintelligible) operating expenses and probably for the first time you've seen operating expenses greater than operating revenues and that is shown on this screen as well. Operating revenue (unintelligible) of course, you know, most of them parking. (Unintelligible) parking. We've got the concession sales. Ranging (unintelligible) are down, however with (unintelligible) be able to (unintelligible) we will get that back at the back end of this. But again, (unintelligible) here. I wish I could.

Man: Does the operating revenue include the federal money?

Michael Zonsius: No. It would not. It will not, because what we regard as secured debt, those are non-operating expenses. And so I don't - and it's good that way because, you know, as I showed you everything would look good. And (unintelligible) it will be good. And here we have the operating revenue divided by the (FPO) (unintelligible) rest of the airport. I separate those because those are kind of like a separate business. Not every airport has one. So I think (unintelligible) at the airport.

Operating expenses are coming down which is probably one of the few good things. (Unintelligible) for the past (two) years. Operating expense again, (unintelligible) for expenses for the (FPO) or course is the (unintelligible) sales across from the fuel for the sale (unintelligible) processing fuel yes, for the sale. And that's broken down between (Jet) A and the (unintelligible) which is for the (unintelligible).

I understand the (unintelligible) is still doing good. It still has cash in these times. You know, so (unintelligible) says, you know, it's a good idea that we, you know, when we get this CARES money perhaps we defer some of it to the next year, only because it will help us meet our debt service coverage into the

next year.

Because, you know, right (unintelligible) right now, this next year when we start in 2021 that we just don't know what it's going to look like. We're planning on, you know, \$1.2 billion in finance which is good. Anything over \$1.1 billion, you know, I (unintelligible). Cash and cash equivalents, everything was good on that. Capital - we're finishing up our project here for the garage. So we spent a lot of capital.

We don't have any really major, major deposits going out at this time. And then of course, the debt (unintelligible) very important. The second project would then - we're just leading our capital. This is the net passenger schedule and I'll just put this for some reference. And this is on a monthly basis. When it's provided to you though in the financial reports, I provided that on a weekly basis for the third week of the last month.

The reason is because it's scheduled to change so frequently and they change from one day Monday, to Friday, the 7th. They're all different. But in the financial statements, I grouped them all and I gave you one week because they are grouped. If you look at the third week of April or the third week of May versus what they put out the third week of June, you'll see a decrease of 45 (flight)s and then we have a decrease of (30) (flights on United to Chicago. But (unintelligible) reflective of the (unintelligible) weeklies in your financial report is automatic to follow the monthly (unintelligible). Any questions?

Man: Questions for Michael?

Man: This is a substantial jump between May and June, so that's going to be a good benchmark.

Michael Zonsius: That's going to get a lot of (unintelligible) for Southwest. Southwest is going to increase their traffic to Baltimore and Orlando.

Man: Even in - even on (commanded) weights and seats? I mean it's all pretty much a big jump between now and next month.

Michael Zonsius: It was a big jump. Yes. You know, and that's why (unintelligible) compared the third week of January to the (unintelligible) the other way. That took effect in April and May and now (unintelligible). But yes, (unintelligible), Baltimore (unintelligible).

((Crosstalk))

Michael Zonsius: Delta now maintains its service (unintelligible).

((Crosstalk))

Man: Is that going to be an issue for us as far as...

Michael Zonsius: I believe that other - I don't think it will. No.

Man: Okay.

Man: AAAE (unintelligible) shouldn't (unintelligible). One good thing that's from Southwest I think, you know, because we have a strong relationship with them, they gave us notice by September (unintelligible).

Man: Okay. Any other questions for Mike? Thank you, Mike. (John LaClair), project development?

(John LaClair): Thank you, Mr. Chairman. Okay. This is the project development report. The first item on the list is (unintelligible) each other (unintelligible) and I hate to say it but (unintelligible) COVID, but we were able to really expedite this job with the reduced number of flights. (Unintelligible) was able to get a lot of work done during the day that normally you wouldn't be able to do.

They had a substantial amount of thresholds (unintelligible) under (tax) (UA)s, existing (tax) (UA)s that were able to be done during the day. It really sped this job up. This job is on track to complete shortly. The only hold up is we have a - we have one set of lights that we're waiting on. The manufacturing company that makes them was shut down for a while. But we are expecting them in July and we'll put them in.

But the rest of this project should be complete by the end of this week as far as everything else. It's just to be we have to plug in the lights and be done. So this - we took advantage of a bad situation. Let's leave it at that. Okay. The drainage job - the drainage job - this is right (unintelligible) road. They had work to do at the South end from wave one. And that definitely affected the flights. We had to shorten the approach pattern, we had - the landing approach for that was short enough.

We gave - the other (unintelligible) with us and we set it up with them to go into two weeks. But the (unintelligible) the whole area, two (unintelligible) they put it all the way across the end of the runway and then did all re-drainage and they were done in less than two weeks.

It's been my (unintelligible) and it turned out that what we did actually made the (unintelligible) better. So that was again, we took advantage of the situation. That was all going to be done (unintelligible) over seven, eight weeks and we did it in about 13 days.

Man: That was (unintelligible)?

(John LaClair): That was (unintelligible). Yes. Moving onto bridges, the jet bridges, this will be an action item for later in this meeting, but we did bid the (unintelligible). Also included in that is the removal of the tool to the wing jet bridges. So that will be an action item for later in this meeting. (Steve) will be presenting those to you for approval. I think the number (unintelligible) produce but they're good.

All the new equipment is in. Unfortunately we don't really get a chance to use it as much as we want. We did close down the garage, the old garage, which actually worked out well for me because we had (unintelligible) do a quick little ceiling patching (unintelligible). With all the floors empty they were able to get in and out in five days and seal all the floors. And we did it with our own in house (unintelligible). All we had to do was buy the material.

We saved a substantial amount of money doing it that way; way over half a million dollars was saved doing it that way. And they were in and out in five days. They did (unintelligible) and sprayed it and put the (unintelligible) and sprayed it and (unintelligible). That looks good. So in doing so we had one weekend where we had one level of the garage, we opened level three. And we did test the (revenue) equipment and it was working very well.

You can see (unintelligible) and you see the number on that board by one. So it's working. Unfortunately it's not getting tested as much as we'd like to but we're working on it. There's the parking garage. It's in the (unintelligible) working on just a little (unintelligible) items, you know, had a little. But other than that it's ready to go. We're ready to open this up and when we get the okay to do so all of the equipment has been tested. Unfortunately the license

plate reader equipment that goes inside the (unintelligible) equipment needs cars in there to actually learn. So we can't test reading license plates.

But in the meantime it's ready to go, it's ready to be tested. We shut it down just to save energy as far as bills (unintelligible) so we've shutdown the lighting as much as we can. Only essential lighting now. We shut down the power for other equipment. We're trying to save some money. But it's ready. When they're ready we're ready. (Unintelligible) square the new ceiling on top, the new lighting. You can see the (unintelligible) set up notes with the bar. We did that all stone and (unintelligible) the new furniture inside, the new tile, the new terrazzo.

Again, that's - we got (unintelligible) people here and there doing (unintelligible) work but I mean again, we're ready to put (unintelligible) and open things up when they're ready. I know Phil and everybody (unintelligible) concessions and get them open again. And as they open we'll adjust the furniture accordingly for social distancing and that type of thing. But it's there. I mean you can see it's there and it's ready to go.

So here is another action item. Again, I'm taking advantage of a bad situation. That is actually our long term parking behind short term, on the grass. We closed up a large section of this and also closed off the employee parking lot and moved them. So we put out bids to repave it. And we got some phenomenal numbers on this. The contract is (resolving) (unintelligible) production. It's not piecemeal work and actually blocked out about a half million to do it. But because we can do it in one fell swoop without any interference, our prices are actually coming in very low.

We have to see it's (unintelligible) for approval, but it's under \$200,000 which is pretty good again. Again, making the best of a bad situation. Air traffic

control - we're ready when they are. Unfortunately as Phil told you, they have their own protocols. We have to wait for them. They're on lockdown. They're really not letting us in except for basic maintenance items. That's all they'll let us do.

They have their own protocols. The one thing that changed their protocol where they open up more it's like we're ready to go in and complete the work (unintelligible) elevator work, and roof work. We have - and it's actually (unintelligible) so it's site work that - we're ready but we're on hold until they let us.

The (unintelligible) is the - replacing the old (unintelligible) another one of our and that's the (unintelligible). The work stopped because it was considered nonessential. So work was stopped on that. We do have all of the equipment. All of the equipment is here ready to be installed. All of the new (unintelligible), the tile work is basically done. But as of right now, HMS has put a hold on it with their contractor. HMS is the concessionaire. They put a hold on that with the contractor.

So once they get ready it'll be about - take about three weeks. I talked to (unintelligible) doing the work. They said they can get it up and running in about three weeks. So - but that's (unintelligible) that. And I'm happy to take any questions if you have any.

Man:

Questions for (John)? Thank you, (John). (Peter Stuto) is there a counsel report? I guess not. The concessions report and the public affairs report you have in print on your program so you can read that at your leisure. And we'll go right to the action items. The first one, 10.1 is (Steve) and this is about the boarding bridge improvements.

(Steve): Thank you very much, Mr. Chairman, Father (Doyle). I'm very pleased to report agenda item 10.1 received very competitive bids for (unintelligible) bidding environment. (Unintelligible) to award our first FAA airport improvement (unintelligible) contract number (unintelligible) general construction has programs with the Federal Aviation Administration under this year's entitlement grant number 142.

The three competitive bids were received after wide advertising. The low bidder is (Harrow) Bridgeworks Incorporated of Marietta, Georgia and has been vetted and recommended by the (unintelligible) hearing in (unintelligible). And so we're recommending your authorization to proceed with this general funded contract, \$2,520,000. Let me clarify, the funding is 90% under the passenger entitlement grant number 142 of 2020, and 10% CARES Act funded.

So those two combined at the 100% federal, AIP plus 10% CARES Act. There is no state or Authority share on this (unintelligible) related item.

Phil Calderone: And that was an additional piece of the CARES Act that we lobbied for. So this is over and above the \$10 million. This is money - this is not over and above the \$15 billion money so there is no local match that applies the CARES Act.

Man: Terrific.

(Steve): So a final note, the final execution of the contracts will be contingent on (unintelligible) contract work because their program over the past years and very favorable bidding once again, competitive bidding and (unintelligible). I'd be happy to answer any questions on this (item).

Man: So in the C terminal there won't be any more back entrances to the planes, right?

(Steve): You would be over the wing (unintelligible) Southwest terminated (unintelligible) here December 31st by Southwest. So the removal of the tool (unintelligible) was a late add to this program which replaces the 20-year-old bridges in A3, A5, P10 and Charles 1.

Man: So I want to clarify that scope (unintelligible).

(Steve): After 20 years of abuse our non-functioning (unintelligible).

Man: Yes. Any other questions for (Steve)? So we need a motion to approve this contract. (/sari). Second, Dr. (Greenberg). All those in favor. Aye. Okay. That's approved. And (Steve), I think you're on for 10.2 again on the boarding bridges, right?

(Steve): Thank you, Mr. Chairman. I have 10.2 relating to the prior item, to contract (unintelligible) which is required to be broken out under the New York State (WIX) law for the same program scope replacing the bridges A3, A5, P10 and Charlie 1. (Unintelligible) competitively bid, three bids were received. Very competitive bids again. Under the engineer's (unintelligible) for awards better than review by staff and the recommendation to work the contract (unintelligible) to the low bidder, (Arrow) Bridgeworks, Incorporated, Marietta, Georgia.

Again, this is a page 4 of 6 program, (unintelligible) bridge replacement of that also. And in prior phases (unintelligible) the low bidder for (unintelligible) also worked with a (unintelligible) electrician who bid on the (unintelligible). So this is not unusual (unintelligible) the same bidder. So the

(unintelligible) work here (unintelligible) the electric portion, the electric contract \$694,000 similarly funded under grant 142 of the share entitlement 90% and 10% carry back. So there is no state nor any Authority funding. It's 100% federal with 90% entitlement and 10% share. I'd be happy to answer your questions on this slide.

Man: Questions for (Steve) on that? Motion to approve the electrical, (Sam). Second, (Tony). All those in favor aye. Thank you. In 10.3 I want to make a comment on this before we start. And just to say that this award is contingent upon the compliance with the minority and women requirements. And each contractor and subcontractor have to have an apprentice agreement for all trade that's been registered and approved by the New York State Commission of Labor. So all of that covers this 10.3.

And (John LaClair), you're going to talk about that - the employee parking lot paving.

(John LaClair): Thank you, Mr. Chairman. As I said during the (unintelligible) taking advantage of the opportunity to have two big lots filled and paved. All bulk in doing so we bid this out and we got some really low prices. And the low bidder for this contract is 1009 (EAV) is \$195,800.92 and that was Newcastle Paving from Troy, New York.

The scope of this work is like I said, (unintelligible) pave it and (unintelligible) surprisingly that we had a half a million dollars earmarked and because it's vital (unintelligible) we got such great prices which is a good thing. So (unintelligible) airport funded but it's an opportunity that I don't know if we'll ever get again between now and (unintelligible) when we get in (unintelligible) done like this.

They could easily go two to three times higher if we had (unintelligible). So I think this is a really good opportunity, but I'm willing to take any questions on this.

Man: (Tony), who is Newcastle? Do you know them?

(Tony): (Dave Valenti) and...

Man: Oh, is that right? Yes.

((Crosstalk))

Man: (Unintelligible).

Man: Any questions on this? Motion to approve the parking lot pavement, Dr. (Greenberg). Second (Terry). All those in favor, aye. Thank you, (John). (Steve), we're going to talk to you about the CHA and the master plan, right?

(Steve): Thank you, Mr. Chairman. I have 10.4 on the agenda (unintelligible) authorization to (unintelligible) contract S1042 CHA. The whole thing is (unintelligible) in preparation of the airport master plan. As authorized at the prior board meeting (unintelligible) negotiation was granted and we have successfully negotiated with an independent fee estimate all in the FAA (unintelligible) for selection of professional consultant services for airport (unintelligible) project. And we come to the resolution that represents for your consideration today, full scope.

The contract (amount) is \$749,965 which will be (KIP) grant funded 90% and 10% CARES Act also, so it will be (unintelligible) share. At this time, Dr. (Folder) will provide a consolidated 20-year version for (unintelligible)

airport. That the master plan - the full master plan was done in 1976 by (unintelligible) who was (unintelligible) ALP update for terminal development.

(Unintelligible) and we've been doing (unintelligible) divisions on an annual basis for all other capital improvements and (revisions), but (unintelligible), the recession of 2008, et cetera.

So it's very timely and appropriate because (unintelligible) as our Chief Executive, has made (unintelligible). I'm excited to present this to you. The contract is contingent on satisfaction of federal (unintelligible) business programs. The program appears to be very well satisfied that that will be further concerns with (unintelligible) about 20% (unintelligible) 4% goal (GDP). Also, FAA (unintelligible) awards for the contract advantage (unintelligible).

So there may be minor technical decisions for the scope (unintelligible) deliverables (unintelligible). The final scope is 2/3 (unintelligible) agenda and we're really comfortable with it being that. And it does appear to satisfy and go above all FAA requirements of the advisory (unintelligible), the design of airports, the airport master plan in development, and (unintelligible) with FAA on this contract as well. So with that, I'd be happy to answer any questions about the federal funding (unintelligible) for the contract.

Man: What did we approve at the last meeting? We approved entering into negotiations...

(Steve): Correct.

Man: ...with (Bob Parker). Right? And this is the number that they've come up with

and...

((Crosstalk))

(Steve): This is the amount that we were awarded by FAA and this is what we told them we had.

Man: Good. Okay.

(Steve): They wanted a lot.

((Crosstalk))

(Steve): They were over a billion dollars with what they wanted and, you know, (unintelligible) negotiated with them and Michael as well, helped and we got to (unintelligible).

Man: Do they have a team leader?

Man: Yes. The team leader (unintelligible).

(Steve): There's a team leader and a consultant with which (unintelligible) financials were brought down. We had (unintelligible) adjustments with (unintelligible) coordination issue with the contract and that's the fee estimates (unintelligible) and he'll ask you where the (unintelligible) follow the FAA criteria and guidance of the (unintelligible) selection (unintelligible).

Man: The (ALP).

(Steve): They were (unintelligible) to meet in the middle or below the middle and still

ensure full deliverables even with the (unintelligible). So a quick synopsis of a full month's effort. Thank you.

Man: Motion to approve this contract with CHA and (unintelligible)? (Kevin) moves. (Sam) second. All those in favor. Aye. Thanks. Thank you, (Steve). And then we have a couple of change orders on the parking garage and (John), you're going to handle those. Right?

(John LaClair): Yes. Thank you, Mr. Chairman. Okay, let's - starting with Item 11.1, I'm looking for the board's authorization to (unintelligible) number 7 to (unintelligible) SF with the foundation for the new parking garage to (unintelligible) financial services. As you'll notice, this is a credit. This is for a well that was not developed and we didn't have the measures to handle this. This is the (unintelligible) that was brought in. This is a vital changeover for this job.

We're (unintelligible) this job out and assuming the changeover gets approved the vital contract increase over the original bid price will be under 7-1/2% on this job, which with that site was not bad at all. That was a pretty (unintelligible) as the board is aware from some of the (unintelligible) you have approved for me. But this is (district credit) and I wanted to make sure that the board knew that we realized that. It was something that didn't pan out the right way. So we didn't just let it go away. We made them pay back for that.

Man: So we need a motion to accept the \$162,000. Right?

(John LaClair): Actually we'll be getting 62.6 (unintelligible). Right?

Man: Correct.

(John LaClair): Is that enough?

Man: No.

Man: Motion from Dr. (Greenberg)? Second, (Sam). All those in favor.

Man: Aye. And let's see, (John) you have the sign, the gateway sign, right?

(John LaClair): (Unintelligible) for the many (unintelligible) parking guys. It does - which does include the gateway sign too but this is for the general construction part itself. Again, this is a vital changeover to close out the (unintelligible) as far as the (strategy) (construction). This is the GP. This is for (unintelligible) \$200,000 and by contract that's the contract of bonus money for completing ahead of time. They did complete it within 20 days in advance of the contract, so this is the bonus money.

There is a lot of other back up material. You'll see it at the board agenda and what that is, is negotiates prices back and forth between credits owed to us and additional work that they did which basically became zero. Not basically. Became zero. So the only thing we owe them is \$200,000 only and that will close this project up.

Man: We're meeting the timeline up at the (unintelligible).

(John LaClair): We're meeting the timeline (unintelligible) by contract 20 days (unintelligible) get that. So this will close - if the board approves this \$200,000 this will close this project out with the same percentages (Sam) that we looked at, and then (unintelligible). Just so you know, even with all of the changes including the (moment), the contract price came in at 7.7% over the original (date). We

were low in the (unintelligible) which was pretty good. But again, this site was a tough site and it's tough to see we're working there.

Man: And as I mentioned, you know, those last couple of weeks during the Coronavirus crisis they kept the work going.

(John LaClair): Yes. They kept the work going and we (unintelligible) and that's with the bonus. So that's pretty appreciable.

Man: We don't have any discretion here. We agreed in the contract that...

(John LaClair): Correct.

Man: ...that we do give them back this money.

(John LaClair): Correct.

Man: Okay. Motion to approve, (Sam). Second, (Sari). All those in favor. Thanks, (John). Phil, we're going to talk about the safety directive.

Phil Calderone: So I mentioned earlier in the slideshow, one of the things that we're proud of here is that we have been taking I think very proactive steps to make sure that all of those who enter our terminal are safe. I want to make sure that everyone also leaves the terminal safe as well. And so what we like to put into play with the board's permission, are some directives that are consistent with published CDC guidelines for the operation of Uber, Lyft, taxicab drivers and shuttle drivers, who come onto airport property.

It's requiring them to - the drivers to have face masks, requires passengers to wear face masks, will require a protocol that the cabs - the vehicles - Uber and

Lyft vehicles maintain a log of every (unintelligible) if it's sanitized after each passenger so if the passenger for the airport wanted to see that log that log would be produced. So it's another step that we're talking to ensure the traveling public that they're safe if they come to this airport and when they leave and get into a cab or a vehicle that is also taking steps to ensure they're safe.

Man: So there's no financial component to this? It's just...

((Crosstalk))

Man: ...Phil to make sure the ground transportation stays safely.

Phil Calderone: This is going to require me to directly (unintelligible) and possibly a member of (unintelligible).

Man: Motion to approve that, Dr. (Greenberg). Second, (Tony). All those in favor. Aye. Thank you, Phil. And now we have to authorize a couple of grants. (Steve), you're on the airport master plan, right?

(Steve): Thank you again, Mr. Chairman. For this report we're ready to accept the federal airport (unintelligible) program grant number 141 of 2020. There is no safety (unintelligible) deleted. As mentioned, it is 90% federal AIP with 10% (unintelligible) funding which is 100% federal. (Unintelligible) 90% share is going to be 5000, 1.6 is the 10% CARES Act for a total of \$751,155 with respect to the (unintelligible) contract authorized previously.

It was reviewed and confirmed with FAA staff and we do (unintelligible) the FAA grant documents. The backup presented to (unintelligible) agenda was the application (unintelligible) signed by (CDO). I'll be answering questions

on this federal (VIP) grant.

Man: I'm wondering about the figures. You said 700,000 and some and our materials...

((Crosstalk))

Man: Okay. Okay.

(Steve): I'm wondering which (unintelligible).

Man: Okay, great.

(Steve): I've got it here and it is strictly the (unintelligible) contract authorized the two items.(unintelligible) towards the agenda is 10.2 with (EHA) consulting (unintelligible) small independent estimate purchase order including for federal reimbursement as an eligible expense.

Man: Okay. So \$751,000 is correct?

(Steve): ...for that at the same (contract).

Man: Okay. Good. Motion to approve that? (Sam). Second, (Tony). All those in favor? Aye.

((Crosstalk))

(Steve): ...planning in a few years so it...

((Crosstalk))

Man: I mean one of the things that we depend on is (unintelligible). So - and it's a requirement, a number of community outreach efforts to advise the community (unintelligible) as well as we're going to want to go to the editorial board; we're going to want to, you know, inform the public we'll be looking for their input. So it's difficult to use a lot of that, you know, in a Coronavirus situation. So we may delay some of the (unintelligible).

(Steve): We're fully (unintelligible) periodic meeting reports among the multiple advisory committees and three public meetings (unintelligible). We'll work that (unintelligible).

Man: I think we have one more contract - a grant to approve. And that's the boarding bridges and that is the 3.5. (Tony)?

(Tony): Thank you, Mr. Chairman. Item 13.2 of the (unintelligible) federal airport (unintelligible) program grant number 142 of 2020 (unintelligible) design and construction. (Unintelligible) is the designer of record. The competitive bid has been authorized and the total combined design with construction budget is covered by this grant, totaling \$3,147,000 (unintelligible) the 90% (AIT) shares supplemented by the 10% CARES Act (248970) for a total program just shy of \$3-1/2 million, (unintelligible).

So this has been coordinated with FAA staff and the application was in the agenda and we do expect the federal paperwork to intend to moving things up so we see this as a July 4th meeting since the meetings are on the 4th of the month (unintelligible) favorite airports. They're keeping us on track as this is fully funded. So we appreciate your support.

Man: Motion to approve the acceptance of the FAA grant? (Sari). Second, (Sam).

All those in favor, aye. Thank you. Thanks, (Steve). Phil, anything else? Is there no old business, new business? No executive session?

Phil Calderone: No executive session unless the board feels there's a need for one. We'll have an opportunity afterwards to meet (unintelligible) and (Sue Blanchard) who will be starting (unintelligible) the (counties) of the council and the (unintelligible) directors. So it looks like we have them onboard.

Man: (Unintelligible). Can we go into executive session? I have a question.

Man: Sure. Absolutely. Motion to go in executive session. (Sari) moves, (Sam) second. All those in favor, aye. We're in executive session.

((Crosstalk))

Operator: Has left the conference.

END



ALBANY COUNTY AIRPORT AUTHORITY
ALBANY INTERNATIONAL AIRPORT
ADMINISTRATION BUILDING
SUITE 200
ALBANY, NEW YORK 12211-1057

TEL: 518-242-2222
ADMIN FAX: 518-242-2641
FINANCE FAX: 518-242-2640
SITE: www.albanyairport.com

ALBANY COUNTY AIRPORT AUTHORITY

REGULAR MEETING

AGENDA

June 8, 2020

General:

1. Chairman's Remarks
2. Approval of Minutes
Regular Meeting – April 6, 2020
3. Communications and Report of Chief Executive Officer
4. Interesting Correspondence

Management Reports:

5. Chief Financial Officer
6. Project Development
7. Counsel
8. Concessions/Ambassador Program (Refer to report.)
9. Public Affairs (Refer to report.)

Action Items:

10. Authorization of Contracts/Leases/Contract Negotiations/Contract Amendments
 - 10.1 Construction Contract: Authorization to Award Construction Contract 1039-GC Passenger Boarding Bridge Improvements to AERO Bridgeworks, Inc.
 - 10.2 Construction Contract: Authorization to Award Construction Contract 1039-E Passenger Boarding Bridge Improvements to AERO Bridgeworks, Inc.
 - 10.3 Construction Contract: Authorization to Award Construction Contract 1009-PAV Long Term and Employee Parking Lot Paving to New Castle Paving
 - 10.4 Professional Services: Authorization to Award Contract S-1042 with CHA Consulting, Inc. for Preparation of the Airport Master Plan

11. **Authorization of Change Orders**
 - 11.1 **Change Order #7: Authorization to award Change Order #7 (credit) to Contract # 989-SF New Parking Garage Site and Foundations to LeChase Construction Services, LLC.**
 - 11.2 **Change Order #8: Authorization to award Change Order #8 to Contract # 989-GCr New Parking Garage (Gateway Sign) General Construction to LeChase Construction Services, LLC**
12. **Authorize CEO to Issue Safety Directives to Ground Transportation Providers at the Airport Due to Covid-19**
13. **Authorization of Federal and State Grants**
 - 13.1 **Acceptance of Federal Airport Improvement Program Grant No. 3-36-0001-141 2020; Prepare Airport Master Plan**
 - 13.2 **Federal/State Grant: Acceptance of Federal Airport Improvement Program Grant #3-36-0001-142-2020; Replace Boarding Bridge A3, A5, B10, and C1; Remove OTW Bridge C2 and C3; Design and Construction; Phase 4 of 6**

Old Business:

New Business:

Executive Session:

Attorney-Client Privilege Matters:

None

NOTICE



ALBANY COUNTY AIRPORT AUTHORITY
ALBANY INTERNATIONAL AIRPORT
ADMINISTRATION BUILDING
SUITE 200
ALBANY, NEW YORK 12211-1057

TEL: 518-242-2222
ADMIN FAX: 518-242-2641
FINANCE FAX: 518-242-2640
SITE: www.flyalbany.com

*Facebook Lobby 5.28.20
Schald*

ALBANY COUNTY AIRPORT AUTHORITY

MEETING NOTICE

Notice is hereby given of the following regular meeting of the Albany County Airport Authority:

The Albany County Airport Authority will hold its regularly scheduled meeting on Monday, June 8, 2020 at 11:30 a.m.

Due to COVID-19 this will be a telephonic meeting. The call in number for the meeting is 866-590-5055 or 816-423-4282 Access Code 3535358.

TIMES UNION

timesunion.com

Albany Times Union
News Plaza
Box 15000
Albany, New York 12212

ALBANY INTERNATIONAL AIRPORT
737 ALBANY SHAKER RD
ADMINISTRATIVE BLDG SUITE 204
ATTN: KATIE KANE
ALBANY, NY 12211

Account Number: 061026000
Order Number: 0004111413
Order Invoice Text: Meeting Notice 6.8.20

R Bernard / T Duquette / C Finnegan / P Sheehan / A Rubel of the city of Albany, being duly sworn, says that he/she is principal Clerk of THE TIMES UNION, a daily newspaper printed in the county of Albany, Town of Colonie, and Published in the County of Albany, Town of Colonie and the city of Albany, aforesaid and that notice of which a printed copy is annexed has been regularly published in the said ALBANY TIMES UNION on the following dates

06-01-2020

SUSAN R WRIGHT
NOTARY PUBLIC, STATE OF NEW YORK
Registration No. 01WR4793115
Qualified in Albany County
My Commission Expires 1/31/22



Abigail Rubel 6-2-2020

Sworn to before me, this 2 day of June 2020

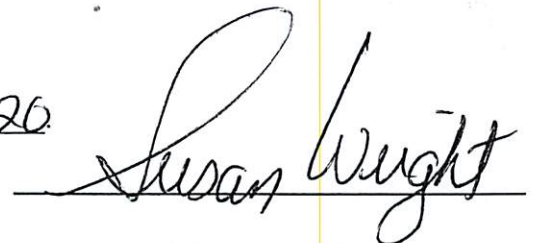

Susan Wright

Notary Public
Albany County

ALBANY COUNTY AIRPORT AUTHORITY

MEETING NOTICE

Notice is hereby given of the following regular meeting of the Albany County Airport Authority:

The Albany County Airport Authority will hold its regularly scheduled meeting on Monday, June 8, 2020 at 11:30 a.m.

Due to COVID-19 this will be a telephonic meeting. The call in number for the meeting is 866-590-5055 or 816-423-4282 Access Code 3535358.

TU1t 4111413

Liz Charland

From: Liz Charland
Sent: Thursday, May 28, 2020 10:44 AM
To: 'Kenneth Doyle'; 'Kevin R. Hicks, Sr. - IPAD'; 'Kevin R. Hicks, Sr. (Personal)'; 'Lyon Greenberg, MD'; 'Lyon Greenberg, MD - IPAD'; 'Rev. Kenneth Doyle (Personal)'; 'Samuel A. Fresina'; 'Samuel A. Fresina - IPAD'; 'Sari O'Connor'; Steve Heider; 'Steven H. Heider'; 'Tony Gorman'; 'Tony Gorman - IPAD'
Subject: ACAA Board Meeting Monday June 8, 2020 - THIRD FLOOR CONFERENCE ROOM IN TERMINAL
Importance: High

ALBANY COUNTY AIRPORT AUTHORITY

MEETING NOTICE

Notice is hereby given of the following regular meeting of the Albany County Airport Authority:

The Albany County Airport Authority will hold its regularly scheduled meeting on Monday, June 8, 2020 at 11:30 a.m.

Due to COVID-19 this will be a telephonic meeting. The call in number for the meeting is 866-590-5055 or 816-423-4282 Access Code 3535358.

Liz Charland

From: Liz Charland
Sent: Thursday, May 28, 2020 10:43 AM
To: TU Legals
Subject: Please publish one time ASAP. Thank you.
Importance: High

ALBANY COUNTY AIRPORT AUTHORITY

MEETING NOTICE

Notice is hereby given of the following regular meeting of the Albany County Airport Authority:

The Albany County Airport Authority will hold its regularly scheduled meeting on Monday, June 8, 2020 at 11:30 a.m.

Due to COVID-19 this will be a telephonic meeting. The call in number for the meeting is 866-590-5055 or 816-423-4282 Access Code 3535358.

Liz Charland

From: Liz Charland
Sent: Thursday, May 28, 2020 10:43 AM
To: 'Saratogian Newspapers'; 'The Colonie Spotlight'; 'The Gazette'; 'The Troy Record'
Subject: Please publish in the community section of your paper. Thank you.
Importance: High

ALBANY COUNTY AIRPORT AUTHORITY

MEETING NOTICE

Notice is hereby given of the following regular meeting of the Albany County Airport Authority:

The Albany County Airport Authority will hold its regularly scheduled meeting on Monday, June 8, 2020 at 11:30 a.m.

Due to COVID-19 this will be a telephonic meeting. The call in number for the meeting is 866-590-5055 or 816-423-4282 Access Code 3535358.

Liz Charland

From: Liz Charland
Sent: Thursday, May 28, 2020 10:42 AM
To: Bart Johnson; Bob Heitz; Brandon Russell, Majority Counsel; County Executive Daniel P. McCoy; Dave Collins; Douglas A. Bullock, Albany County Mass Transit Committee Chair; Eric Anderson; Fire Chief Dave Cook; Frank Mauriello, Albany County Minority Leader; Fred Acunto; George Penn (Albany County); Jill Bryce; John DelBalso; Lynne Lekakis Mass Transit Committee; Majority Leader Dennis Feeney; Mike DeMasi (Business Review); Mike DeSocio; Pam Allen; Pete Rea (prea@dot.state.ny.us); Spotlight News; WRGB News
Subject: ACAA Telephonic Meeting Monday June 8, 2020 at 11:30 a.m.

ALBANY COUNTY AIRPORT AUTHORITY

MEETING NOTICE

Notice is hereby given of the following regular meeting of the Albany County Airport Authority:

The Albany County Airport Authority will hold its regularly scheduled meeting on Monday, June 8, 2020 at 11:30 a.m.

Due to COVID-19 this will be a telephonic meeting. The call in number for the meeting is 866-590-5055 or 816-423-4282 Access Code 3535358.

AGENDA ITEM NO. 1

Chairman's Remarks

AGENDA ITEM NO. 2

Approval of Minutes

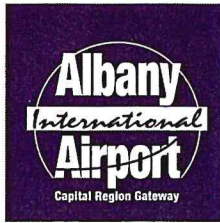

ALBANY COUNTY AIRPORT AUTHORITY
 ALBANY INTERNATIONAL AIRPORT
 ADMINISTRATION BUILDING
 SUITE 200
 ALBANY, NEW YORK 12211-1057

TEL: 518-242-2222
 ADMIN FAX: 518-242-2641
 FINANCE FAX: 518-242-2640
 SITE: www.albanyairport.com



ACAA Approved
06/08/2020

Minutes of the Regular Telephonic Meeting of the Albany County Airport Authority

April 6, 2020

Pursuant to notice duly given and posted, the regular telephonic meeting of the Albany County Airport Authority was called to order via teleconference on Monday, April 6, 2020 @ 11:30 a.m. by Chairman Kenneth J. Doyle with the following present:

MEMBERS PRESENT

Rev. Kenneth J. Doyle
 Tony Gorman (via telephone)
 Lyon M. Greenberg, M.D. (via telephone)
 Steven H. Heider (via telephone)
 Kevin R. Hicks (via telephone)
 Samuel A. Fresina (via telephone)
 Sari M. O'Connor (via telephone)

MEMBERS ABSENT

STAFF

Philip F. Calderone, Esq.
 Michael F. Zonsius (via telephone)
 Peter Stuto (via telephone)
 Liz Charland
 Matt Cannon
 Steve Iachetta (via telephone)
 Helen Chadderdon (via telephone)
 John LaClair
 Margaret Herrmann (via telephone)
 Kathy Greenwood (via telephone)

ATTENDEES

Fred Acunto, Airport Manager, AvPorts (via telephone)
 John DelBalso, Assistant Airport Manager, AvPorts (via telephone)
 Bob Heitz, Million Air Albany (via telephone)
 Frankie Cocoman, Risk Strategies ACAA Consultant/Agent (via telephone)
 Steve Cook, Daily Gazette (via telephone)
 Michael DeSocio, Business Review (via telephone)
 John O'Donnell, Airport Consultant (via telephone)

General:

- Chairman's Remarks**

2. Approval of Minutes

Ms. O'Connor moved to approve the minutes of the February 3, 2020 meeting.

The motion was adopted unanimously.

3. Communications and Report of Chief Executive Officer

Mr. Calderone presented the Communications Report of the Chief Executive Officer for the month of April 2020.

4. Interesting Correspondence

Management Reports:

5. Chief Financial Officer

Mr. Zonsius presented the Financial Report for the month of April 2020.

6. Project Development

Mr. LaClair presented the Project Development Status Report for the month of April 2020.

7. Counsel

8. Concessions/Ambassador Program

Ms. Chadderdon presented the Concessions/Ambassador Status Report for the month of April 2020.

9. Public Affairs

Action Items:

10. Authorization of Contracts/Leases/Contract Negotiations/Contract Amendments

None

11. Authorization of Change Orders

11.1 Change Orders #5 & 6: Authorization to award Change Orders No. 5 & 6 to Contract No. 989-GCr New Parking Garage General Construction to LeChase Construction Services, LLC.

Mr. LaClair recommended authorization of Change Orders No. 5 & 6 for Contract 989-GCr for the New Parking Garage General Construction to LeChase Construction Services LLC in the amounts of \$235,334.00 and \$96,755.00 respectively, for unforeseen conditions encountered by the contractor during construction. The additional work items for Change Order No. 5 includes changes made to comply with the requirements of the Building Permit, layout modifications to the east plaza, changes to the drainage downspouts and generator fuel tank modification. Included in this change order are two credit items; stair tower modifications and

change of conduit materials.

Mr. LaClair then advised the additional work items for Change Order No. 6 include Conduit protection system, relocation of an existing light pole, painting an existing overhead sign structure, modification of the slab in the Pedestrian bridge for stairs, additional drains, control booth HVAC changes, Level 5 pipe protection, Level 1 & 2 fencing and protection of a National Grid underground electric line.

Discussion in recording attached.

Mr. Hicks moved to authorize Change Orders No. 5 & 6 for Contract No. 989-GCr for the New Parking Garage General Construction to LeChase Construction Services, LLC in the amount of \$235,334.00 and \$96,755.00 respectively. The motion was adopted unanimously

Old Business: **None**

New Business:

Executive Session: Attorney-Client Privilege Matters:

There being no further business, the meeting was adjourned at 12:30 p.m.



ALBANY COUNTY AIRPORT AUTHORITY
 ALBANY INTERNATIONAL AIRPORT
 ADMINISTRATION BUILDING
 SUITE 200
 ALBANY, NEW YORK 12211-1057

TEL: 518-242-2222
 ADMIN FAX: 518-242-2641
 FINANCE FAX: 518-242-2640
 SITE: www.albanyairport.com

ALBANY COUNTY AIRPORT AUTHORITY

REGULAR MEETING

AGENDA

April 6, 2020

General:

- 3. **Chairman’s Remarks**
- 4. **Approval of Minutes**
Regular Meeting – February 3, 2020
- 5. **Communications and Report of Chief Executive Officer**
- 4. **Interesting Correspondence**

Management Reports:

- 5. **Chief Financial Officer**
- 6. **Project Development**
- 7. **Counsel**
- 8. **Concessions/Ambassador Program**
- 9. **Public Affairs**

Action Items:

- 10. **Authorization of Contracts/Leases/Contract Negotiations/Contract Amendments**
None
- 11. **Authorization of Change Orders**
 - 11.1 **Change Orders #5 & 6: Authorization to award Change Orders No. 5 & 6 to Contract No. 989-GCr New Parking Garage General Construction to LeChase Construction Services, LLC.**

Old Business:

New Business:

Executive Session:

Attorney-Client Privilege Matters: None

ALBANY COUNTY AIRPORT AUTHORITY

**Moderator: Liz Charland
April 6, 2020
10:20 am CT**

Ken Doyle: Okay thank you everybody for being here or joining in the magic of cyberspace. Here at the airport, Phil is here and Liz Charland and John LaClair and (Mike Cannon) and myself Father Ken Doyle and I think everybody's on the phone, right?

Phil Calderone: Yes Father if I could just make an opening statement. So, this is a public meeting. It is a regular meeting of the airport's board and it has been duly publicized. This phone call is being tape recorded in accordance with Governor Cuomo's Executive Order 202. So, we're going to proceed under that order and just so that everyone knows, there will be a transcript made of this call to memorialize this meeting of the board.

Ken Doyle: Thank you Phil. Our first order of business is to approve the minutes of our last regular meeting of the February 3.

Ken Doyle: Good.

Ken Doyle: So, a motion to approve the minutes...

Woman: So moved.

Man: Other board members would - others move to approve the minutes. Does the board member...

Man: So moved.

Man: (Unintelligible).

Man: Okay good. I'll second it. All those in favor.

Group: Aye.

Ken Doyle: Thank you. Now we have Phil Calderone's report.

Phil Calderone: Good morning everyone. I hope everyone is staying safe and, you know, following the state and federal guidelines to try to make sure that we practice social distancing, good hygiene and all of the things that have been recommended to make sure that we get through this safely and as soon as possible.

So I wanted to first talk about the effect of the COVID-19...

Woman: (Unintelligible) legislature...

Recording: ...has joined the conference.

Phil Calderone: I wanted to talk about the effects of the COVID-19 crisis on the airport. As you all know, there has been a precipitous decline in the number of flights

coming into the airport and the number of passengers going through TSA terminal.

Last Friday we had probably a good average for the week, less than 150 people going through the TSA checkpoint and probably 30% plus reduction in the number of planes landing at the airport.

So, what does this mean for the airport and its revenues going forward? It's something that we have already begun dealing with. Our CFO will be giving us a report in a few minutes but with his department, we have been looking at all the different cost centers, the expenses of the Authority, and putting together a plan of mitigation to deal with the uncommon loss of revenues that we anticipate experiencing.

We also have these (unintelligible) regarding the CARES Act that the federal stimulus relief package will include \$12 billion for airlines. I was on a very long conversation with AAAE, Airline Association of America on Friday that talked about the distribution of that \$12 billion in CARES Act funding. The good news is that the money will be available for any airport purposes without significant restrictions so that it could come in when it comes in to our general fund as revenue which will help alleviate concerns that we may have to maintain proper get service - reserve coverage for our bond holders. And that's good news.

We will, in the next few days, get a better understanding of how much money exactly Albany International will be getting out of the CARE Act fund. There will be no need, we believe, at the moment, to apply for those funds. The anticipation is that the FAA will, based on a fairly complicated formula, be distributing those funds to equity airports without the need for us to apply.

Just a rough breakdown - and I'll go through this quickly - there will be \$3.7 billion of funds that will be allocated based on 2018 employment, \$3.7 billion based on debt service coverage ratios, \$2 billion based on existing airport improvement entitlement formula without regard to the local match, and then the rest based on a distribution of grant money given to airports.

So, we'll have an understanding hopefully in the next couple of weeks on how those funds will help offset the significant loss of revenues we're going to be experiencing.

In the meantime, you know, and I hope the board is in agreement with this, until we fully understand what the effect of the CARE Act funding will be on our budget and while we're still looking at ways to reduce discretionary funding and expenses related to, for example, utilities, I have decided that we're not going to, unless the board feels otherwise, make any cuts to employees. As you know the Authority, it has been required to reduce staffing levels by as much as 50% pursuant to the governor's executive order and that is an order that directed us to make those reductions without charging employees' accruals. With regard to the other employees here at the airport, for example, employees of AvPorts and employees of Million Air, we've asked AvPorts and Million Air to look at different cost centers to hold on discretionary funding unless they receive my approval.

And with regard to employees, we're trying to see how best we can repurpose employees, for example, shuttle bus drivers, cashier's and the like so that they're, you know, there are other ways that, you know, working with their unions, we can use those employees to fulfill roles that we might otherwise in the past have contracted out for services.

For example, you know, offsetting expenses that we might have spent for landscaping where we might be able to use some of those employees to do general landscaping around the airport.

Painting, repairs, maintenance - those kinds of jobs that we would have paid for through contracted expense lines with the keeping employees employed at least through the end of April.

And then we evaluate where we are once we have a better understanding of the effect of the CARES Act and a better understanding of where we might, you know, be with regard to the airline industry as a whole.

So that's the plan with regard to the financial impact on the airport, going forward at least through the next month.

We meet to some - an update on the Corona virus task force, we meet now once a week. We've been meeting almost daily with the Corona virus task force. It's a task force that I've put together that includes a number of individuals who are essential, you know, to operations here at the airport including, for example, Chief Cook, the folks at Million Air, the folks at AvPorts as well as county health officials who take part in the call, Dr. Dailey from Albany Med has now agreed to be part of that task force and Dr. Greenberg from our board has been extremely valuable to us as an advisor to me throughout this process.

We have been extremely proactive going back probably a month and a half in taking steps to try to protect passengers and staff alike here at the airport and we have been meeting with Homeland Security and TSA and FAA representatives also. All of those agencies have representatives on our task force.

We got a meeting, (Matt Cannon) and I, the other day with a regional representative from Homeland Security. We outlined some of the steps we've been taking at the airport to protect staff and passengers and the comment was their impression is Albany International is ahead of the curve in terms of their comparison of what we're doing with regard to protecting folks as opposed to other airports.

With regard to an update on how we're handling, you know, staff given the fact that 50 to 60% are working from home. We have daily call-ins. Father just sat in on this morning's call-in where we check in on staff mainly to check on their well-being, to review the status of some of the projects that they're working on, to give them an update of what's happening on a daily basis here at the airport and those meetings generally get 100% attendance by staff members. And I'm pleased to say I think they've been proven to be very productive.

And then lastly, with regard to an update on construction projects, we completed work other than punch list items on both the garage and on the terminal within our time frame by the end of March. You know, good news in that, you know, the work was done on a timely basis. It looks beautiful. I just wish you all had the opportunity to be here and to see how great everything looks but that will happen soon enough hopefully and we'll have an opportunity to celebrate and thank everyone who was responsible for doing such a wonderful job in getting the construction projects done on time and on budget.

We had sent out over the past month several RFQs, one on the master plan for the airport. We had three very good responses which we'll be interviewing the three firms shortly and making a recommendation to the board. We had, I

think, almost a half-dozen responses for the office relocation and we'll be reporting back to you on that. And we had three very good responses on the hotel feasibility study and we'll be scheduling interviews on - with those firms, making a recommendation to the board shortly.

And then lastly, we had again continued our relationship with (Cyberlaw) to provide IT services in the field of cybersecurity. I can't think of a more important time than right now with a lot of the mischief that's going on in the world in the cybersecurity world with bad actors trying to take advantage of the COVID-19 crisis and so we're fortunate to have (Cyberlaw) on board protecting the Authority and making sure that we are in a good position with regard to our IT on services.

And then lastly, I just wanted to report to you that discussions continue on with Hudson Valley Community College and looking for - with them to establishing a mechanic certification program here at the airport. I had a conversation with the folks at Hudson Valley on Friday where they remain committed to working with us to create a mechanic certification program here and we will report back to you next month hopefully on progress on that front.

And Father, that's my report.

Ken Doyle: Thank you Phil and thanks for keeping a steady hand on us through this difficult time. Any questions or comments about Phil's report? And Phil I think this is good that we'll keep employees on through the end of April and then we'll take another look at it at the end of the month.

Phil Calderone: Thank you.

Ken Doyle: Michael Zonsius the financial report.

Michael Zonsius: Thank you Father Doyle. February ended on the 29th and it was a very strong month. As you can see in the enplanements we were up 8.3 over budget. For February 19 it was 6.1. Year to date was 6.5 and the previous 12 months we were up 4.1%. Now part of the strong enplanements was because this year we did have a leap year, an extra year, and that accounted probably for about 4,000 enplanements. Had we not had leap year we probably would've went from 1.532 million to 1.528 million which still is a record year or one that would have been a record year as we projected.

I will not go over the PowerPoint presentation, but I'll just go over the financial statements. If you have any questions, please do not hesitate to ask.

On the balance sheet right now, my concern is the cash, cash and cash. And if you look on my narrative, you'll see that we have nine months of operating cash and that's a number that I am very much concentrating on and making sure that we'll have plenty as the CEO had indicated, the big concern is for the debt service covenants which is 1.25 times our debt service.

As for the revenues, we came in approximately 1.9 million year to date and for the month was 1.1 million year to date. For the revenues of 2020 I did make a - that should be 7.34 million, not 73.4 million but both operating revenues and operating expense are both favorable compared to budget and last year.

Million Air operations - the operating profits were favorable for the budget. They were lower than the last year but the reason for that is because last year we had a more snowy February. When it snows more, there's more deicing and hence there's more revenues and more expenses so that less - that amount being less than last year is not of concern to me at this time.

We continue to project for the end of the year according to how Phil had indicated prior and will keep him apprised of how our enplanements are going. Right now, our enplanements - we do not receive them until March or April 10 and at that time we'll release what the enplanements for March are.

I have no other comments unless there are any questions and thank you.

Ken Doyle: Thank you. Questions for Michael? We'll look forward with anticipation and a little bit of fear for your March report.

Michael Zonsius: Probably will be the later.

Ken Doyle: Project development, Steve? Or John?

John LaClair: Thank you Father Doyle I'll do it because I'm here.

Ken Doyle: Okay good.

John LaClair: And probably give you the most current update. Project status as far as airside improvements, the runway tense way and taxi way (unintelligible) job which was started last year is going to resume work by the end of this week. We're taking advantage of the fact that the planes are not - there's a lot fewer planes coming in and out so they're going to be able to get the work done quicker in the intersection.

I just had a conference call this morning so that's going to start up.

The airport drainage and culvert replacement - that actually is - has resumed a week ago. Rifenburg did the work on Old Niskayuna Road and finished that

up last week so that the overflow is there. They're bringing in additional pipe for the safety area of runway one so that's getting stockpiled.

We've been in conference with the FAA regarding shutting that down - the runway down to let them do their work in early May. That may change, obviously, due to circumstances beyond our control but the material's here and Rifenburg's ready to go with that.

The design of the new passenger boarding bridges A3, A5, B10, and C1 is ongoing with C&S. We're anticipating getting that out to bid once we have a better handle on where the finances are going this year and how the AIP money is going - when that's going to be disbursed to us.

As far as the landscape jobs the revenue upgrades and park system, the park system in the old garage is up and running. It - we've shut down the garage but that just gives them a chance to refine the system a little and aim the camera a little better. But, it's ready to go. (Unintelligible) so you can see the way it's going. The LPRs and EZ-Pass is all set in all the parking lots and same with the new garage. Everything is being wired in. There's a few little punch list items to do but that system will be ready to go and it's currently in what they call a learning stage. Apparently, it takes three weeks of the system to learn but the empty spaces are okay so it's learning. You'll see the lights will change color once they go. They're currently in a purple color. They'll change to a green for open spaces. That's working.

Let's go on to the new garage. The new parking garage is for all intents and purposes is done. It's ready to go. There is some punch list items. There always are to do here. Some can't be done until the weather's started to change - some landscaping, some sidewalk but all in all very small items. It's ready to be put into use when we're allowed to use it and when we have a

need for it. So that's good news. And again, as Phil said, the terminal amenities. Same thing, they're - we're doing some punch list work, but the floors are looking good. The lights are in. As Phil, you know, said, it would be nice if people would come take a look at it. It's kind of hard to describe it. One nice thing, anybody can drive by and take a look. The new Albany Airport - Albany International Airport sign is up on the top of the terminal and on the garage so - and at night they are - they do light, so they are lit up. The one on terminal should be lit I believe tomorrow. They're working on the final wiring for it. They just put the letters up so it's all there. You can drive by and you can see even if you're just going by. It's kind of a nice thing that you can drive by and see it.

The rest of the project entirely said they're finishing up some furniture in the seating areas, which is - with Chic-fil-A and both Starbucks closed made it very easy and fast for these people to get in and get their work done. They've had pretty much an open terminal to do their work which is nice so that should be cleaned up.

The water sprinkler service for Building 211, I can't get anything from Layton Water District. They basically shut down due to COVID-19 so they take calls after this subsides, understandable.

The air traffic control tower - pretty much the same thing. We've had designers we've been working with them. I have 90% plans. Not much I can do with them right now because the tower is kind of on lock down. They're not coming in or out due again due to the COVID-19.

And finally, the terminal concessions, the Hudson Valley Wine Bar was shut down and they were starting work on the (Barry Union) but that work is, again, taking a side track due to the COVID-19. They did take the liberty of

all the needed equipment last week, so it is here. It's just a matter of getting the contractor back in to come in and do the final installation and complete the wall finishing, floor finishing's, and it's probably - you're probably looking at two to three weeks of work left to do once they get back. So, that's where we are.

Ken Doyle: Thank you John, any questions for John LaClair? Uh, Helen Chadderdon on concessions and ambassador program?

Helen Chadderdon: Hi Father, how are you?

Ken Doyle: Good thank you, how about you?

Helen Chadderdon: I am doing well, thank you. Along the concessions, of course, the employee count has been impacted dramatically as it has with everything else so when this was written there was 23 employees of the 159 and now, of course have much less. HMS Host has all locations closed except their DBE operator, Dunkin.

OHM now has everything closed. You'll see in my notes there that Chic-fil-A was open when this was written but their last day was actually now Friday so that's pretty much it. There's no food and beverage on the air side at all.

However, Dunkin Donuts is staying open from 4 am until 8 pm and will continue to stay open because now honestly, they're the only game in town. So, they still have five employees so they're at 60% on their minority percentages.

Paradies is keeping up the B store limited hours and the C store limited hours, like, if there's a Southwest flight, the C will stay open. The other flights for

Jet Blue, Delta and American will - the B store will stay open. However, as you can imagine the sales are quite low.

The - as I mention there all of the HMS Host stuff is closed. Dunkin, again, is the only game in town and I just mentioned about the gift shop. With the closing of these locations there was a lot of food in the freezers and the refrigerators. So, we've arranged for all of that to go down to the City Mission.

Ken Doyle: Okay.

Helen Chadderdon: In fact, there's a big - there's a big huge order going down today, you know, several hundred pounds of chicken and hundreds of pounds of other things so it's quite a huge donation.

And of course, on the ambassador side of things, we asked them weeks ago to please stay home because they are primarily an older population and I want them to take care of themselves, so the numbers are of course down dramatically. The hours that we had for the first half of March was only 491 and about 1,800 guests served.

Very light on K9 due to the TDI which does a lot of the certification asked them to please don't bring your pets out during this COVID-19 issue and the numbers at the business center were very light. So that I'm happy to answer any questions should anyone have anything.

Ken Doyle: Thank you Helen and thank you for steering us through this tough time.

Doug Myers, public affairs?

Doug Myers: Thank you Father. I've been working at home since the 17th of March. I'm with uninterrupted communication with all the media. They have my home phone, my cell phone numbers, and my email as well.

I've been providing news releases and advisories that we distribute when things change or when the media must be updated and I'm taking part in the task force phone conversations as well as the staff conversations.

And again, I've been in contact with Phil at any time that he needs me.

We've cancelled all real events at the airport other than allowing the Red Cross to use the observation deck for a blood drive. They have informed us there is a great - for blood in the region and so we've let them use that. I have not heard if they plan on using it at all but if they do, you'll get that in the morning news wrap that I've been sending out and try to update it every afternoon as well in late in the afternoon with events from the Capital Region including the airport.

Happy to answer any questions Father.

Ken Doyle: Thanks Doug. Any questions for Doug?

For action items I think we just have one item that's a change order on a parking garage and John LaClair, you going to tell us about that.

John LaClair: Yes, thank you Mr. Chairman, yes, it's actually a combination of two. If you'll notice it's Change Orders #5 and 6. I combined them.

There's - it's a change order for the Contract 989DCR. It's to LeChase Construction, Inc. Change Order #5, the value is \$235,334 and Change Order

#6 is \$96,755 for a total of \$332,089. This is a - this is part of the garage. It's additional items that were encountered and this does include some credits in there. There's a couple of credits that are involved. But there's additional items to Change Order #5 which include the modification of the East Plaza which is the entry plaza behind the garage.

We had to modify it for the new LPR and part system to make it work. It's just a modification to the islands so that we had to expand them out to make them longer for the cameras to work properly. We had some changes that had to be done to that.

There were some changes to the drainage and the downspouts, just due to the configuration of the garage and what had to get moved as we put the foundation in the garage. We ended up moving some pipes and - that weren't originally anticipated being moved which had been in change orders which were in the SF package so now we had to modify the downspout to meet that.

Well you'll see there a change in the generator fuel tank modification. The tank - the original tank that was spec'd was too tall to be used in the spot that we needed so we bought another tank. Luckily as it turns out, airfield maintenance has a generator that needed a new tank so we took the tank that we replaced and we're using that over there for - so it didn't go to waste so it was a win-win for us that way. And we'll be hooked up to that and there was some modifications to - there's a couple of credits of a spare tire modification and also a decent size credit for the change in the kind of materials in Change Order #5.

In Change Order #6 is some small items that was kind of a protection to protect as we put the thing together and striped the garage some of the ways that they had to route the conduits made them vulnerable to hits as cars came

around ramps so we had to put protection there - protection so we don't damage anything. We relocated an existing light pole and it's the one right outside the Authority building that was never anticipated to be moved but as we did the parking lots we realized it was so close to the edge it was just in danger of falling over so we had them move it and we still need it. You need light for the entrance, so we did that.

And then there's a few other small items that are level five fire protection and level one and two fencing but the fencing in level one and two was never anticipated. But when we put the canopy over the entrance ramps, we realized that somebody would be able to jump through the opening, get on the roof and jump over the security fence and it was a TSA consideration. So that's what brought that apart. That brought that out so those are the items. In the back-up material, there's a lot more information but if anybody has any questions, I will happily answer them.

Ken Doyle: Questions for John LaClair.

(Kevin): I have a question, Father.

Ken Doyle: (Kevin).

(Kevin): John, what percentage are we at now in change orders?

John LaClair: Just over 6%. Not even 6.1, it's 6.0587. I can go out about seven decimal points. Not quite 6.1% yet (Kevin).

(Kevin): And what - does that include the artisan issue?

John LaClair: No actually the artisan well has been the SF contract and no we have not - we're still getting - we're still working with LeChase to get the credit back for that. That has not disappeared. That's in the SF package but that is still an item to be credited back, yes.

(Kevin): Okay so we're looking at on 15, 7, which was the big number, now you're at it's almost 16,7 so you're almost a million dollars in change orders so far.

John LaClair: Correct.

(Kevin): Is that correct?

John LaClair: That is correct.

(Kevin): Okay thanks. That's just trying to crunch my own numbers here.

Ken Doyle: And that's in the ball park in terms of change orders?

Man: Yes, that's well within - I mean in the concession impact on 15, 7 but you know you like to keep them as low as possible.

John LaClair: Absolutely true.

Man: You can argue a little bit on, you know, it's a (unintelligible).

John LaClair: We have. You - the original numbers came in (Kevin) with I would say every one of them has been cut down anywhere from 25 to 35, 40% on some and a couple of them I just sent right back. Didn't even (unintelligible) wouldn't even entertain them so believe me I negotiate these down from a lot higher number.

(Kevin): No, I know that. I trust that John you've been around the block a few times, so you know (unintelligible).

John LaClair: You know (unintelligible) about these things.

(Kevin): Yes, I'm sure of that so thank you very much.

Ken Doyle: Any other questions for John? I think a motion to approve these Change Orders #5 and 6.

Tony Gorman: Tony Gorman...

Ken Doyle: Hi Tony.

Kevin Hicks: So moved.

Tony Gorman: Hi Father.

Ken Doyle: Kevin Hicks makes the motion to approve the Change Orders 5 and 6.

Sari O'Connor: Second.

Man: Second.

Ken Doyle: Sari? Is that Sari?

Man: That was Sari.

Sari O'Connor: Yes it is.

Dr. Greenberg: It's Dr. Greenberg.

Ken Doyle: Sari, okay. We're ready for a vote. A vote to approve the Change Orders 5 and 6. All those in favor?

Group: Aye.

Ken Doyle: Okay anything else? I think we're good, huh?

Man: I do have a question for Phil (unintelligible).

Tony Gorman: It's a great day. That was a great time for me to call.

Ken Doyle: Yeah Tony you called at a perfect time.

Tony Gorman: I thought it was noon, my mistake.

Phil Calderone: Just so the board, you know, is aware, I mentioned earlier that, you know, we're cutting back on utility expenses and then there was some discussion about the new garage not opening up. Part of that is, you know, I'm not, you know, turning on the lights in the new garage. We're trying to, you know, conserve energy there but I've also asked that the old garage also be closed temporarily. We're moving parking in to surface lots and consolidating parking closer to the terminal.

As you know, a while ago we closed the economy lot so we're doing, you know, everything we can to look at ways to reduce cost centers and that's one way by keeping the lights off in both of the garages.

With regarding to just construction contracts, and what work is, you know, being done here, just so you know, the governor has issued an executive order. The 202 Executive Order the general overriding executive order, you know, dealing with the COVID-19 crisis has been subsequently added onto by other executive orders which have given additional direction on dealing with COVID-19 in various different ways and so 2.28 dealt with keeping open essential services that were not subject to the mandatory shut down in aviation was one of those essential services so the airport was exempted, not the Authority but airport operations as an exempted essential service.

202.11, which was issued by the governor not this Friday but the prior Friday dealing with construction contracts it referred back to essential services as defined in that 202.8 order that allowed construction contracts that were essential to aviation purposes to go forward. So projects that are necessary here at the airport with regard to improvements to, you know, the terminal to the runways, etcetera, those are allowed to go forward but things like we mentioned, the Beer Hall, which were, you know, under a separate contract but, you know, not part of the Authority's work and not critical to aviation, we've stopped. And so that's kind of where things stand with construction projects here at the airport. I just wanted to give you a little background on that.

Man: Thank you.

Man: Thank you Phil.

Man: Thank you for (unintelligible).

Ken Doyle: And part of the cost cutting is that we've saved money on having no lunch today for the board. But there's a big pile of cupcakes here and if I can be the board's designee I'll try and take care of those.

Man: Now let me tell you why those cupcakes are here and I want a big round of happy birthdays from everyone. That will be a motion for Father Doyle's 80th birthday.

Ken Doyle: Thank you.

Man: So, let's have a round of applause.

Man: Happy birthday.

Ken Doyle: Thank you very much and thank you for being part of this today and stay well and stay safe and stay home.

Man: Father, I do have a question for Phil.

Phil Calderone: Yes.

Man: Phil I - when you mentioned earlier about trying to transfer some of the...

Man: ...airport personnel on to, you know, so that we could maintain the current staffing levels that we have.

Phil Calderone: Yes.

Man: Have you been getting any push back from their respective unions?

Phil Calderone: No, I think that, you know, based on my conversations with (Fred) and with (John) I think that, you know, there's gratitude and appreciation.

Man: Right, I would hope.

Phil Calderone: Yes, there's also been gratitude and appreciation by the airlines for, you know, our working with them and being good partners.

Southwest called me - the representatives from Southwest last week. While they have nationally reduced when they put out their flight schedule for May and June - May through June and they reduced flights nationally by over 50% for most airports throughout the country. Albany International's flights were only reduced by 25% and they specifically said because of their appreciation for the partnership that we've established with them.

And so, you know, I think that that, you know, attempt here by the airport to try to work with the airlines to try to work with the different partners that we have here whether it's Million Air, whether it's AvPorts, the different unions to get through this together.

The airport has been incredibly successful. I mentioned this to Father before the board meeting. We have substantial reserves and it's not been the result of any one group of individuals. It's been a collective effort here and I think to the extent that we can work together at least through the next, you know, few weeks, to see how this all kind of shakes out and try to support one another. That's kind of the philosophy of management that I've been taking and that I appreciate the board supporting.

Man: Yes I want to thank you for your - for, like, as Father - to echo his comments of your leadership at this time but certainly nothing any of us has ever

experienced before and it's - for the new guy on the block it's kind of a tough introduction to running the airport but this should bring you up to speed pretty quick.

Phil Calderone: I have a great team around me and I appreciate all of their support so thank you very much and thanks to the board.

Man: Thanks Kevin. Well said.

Phil Calderone: Thank you.

Ken Doyle: Motion to adjourn.

Man: So moved.

Ken Doyle: Okay, second.

Man: Everybody stay healthy please.

END

AGENDA ITEM NO. 3

**Communications and
Report of Chief Executive Officer**

Albany
Westchester County
Airport

June 2020



Albany
Westchester County
Airport

COVID-19

**Response
and
Recovery**



Albany
Westchester County
Airport

PRE-PAUSE

Task Force created February 2020

- Albany County Airport Authority Staff
- TSA
- Air Traffic Control
- Albany County Sheriffs Office
- Chief Cook, ARFF
- Dr. Elizabeth Whalen, Albany County Health Commissioner
- Dr. Michael Daily, Albany Medical Center
- Dr. Lyon Greenberg, Airport Authority Board

 **PRE-PAUSE**
Task Force created February 2020

Reviewed & implemented Disaster Preparedness Plans to assure safety of passengers, staff, construction teams, & monitored CDC guidelines



 **PRE-PAUSE**
Task Force created February 2020

Worked with Air Traffic Control on remote work plan for tower operations



 **PRE-PAUSE**
Task Force created February 2020

Worked with CyberWA and airport staff on Disaster Preparedness Plan & security issues for remote work



Albany
Westchester County
Airport
Local Airport Authority

THE PAUSE

March & April

**97%
Reduction
in Traffic**

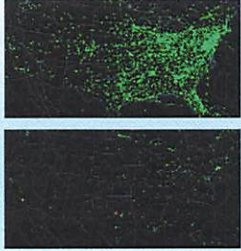

Albany
Westchester County
Airport
Local Airport Authority

THE PAUSE

March & April

**ASSURE SAFETY OF
PASSENGERS**

- Install hand sanitizers
- Distribute bottles sanitizer & lotion to passengers



Albany
Westchester County
Airport
Local Airport Authority

THE PAUSE

March & April

**NEW CLEANING
SAFETY PROTOCOLS**

- CDC approved cleaning solutions
- High intensity sprayers
- Disinfect all Terminal surfaces
- Touchless timekeeping



Albany
The Airport Council
Airport

THE PAUSE

March & April

COMMUNICATE AIRPORT CHANGES

- Unions
- County Sheriff
- Airlines
- Concessionaires
- Media



Albany
The Airport Council
Airport

THE PAUSE

March & April

2020 BUDGET

- Hold discretionary spending
- Limit Capital expenditures
- Repurposing employees





Albany
The Airport Council
Airport

THE PAUSE

March & April

2020 Budget

- Closed remote parking
- Closed parking garages
- Ended shuttles and valet



Albany
International General
Airport
Albany, New York

THE PAUSE
 March & April

COMPLIED WITH EXECUTIVE ORDERS

Remote working-non-essential & high risk groups

Remote construction meetings



Albany
International General
Airport
Albany, New York

THE PAUSE
 March & April

CORDINATED SAFETY PROTOCOLS

Ongoing essential construction projects



Albany
International General
Airport
Albany, New York

THE PAUSE
 March & April

Lobbied for CARE Act funding

Enhanced Airport public messaging

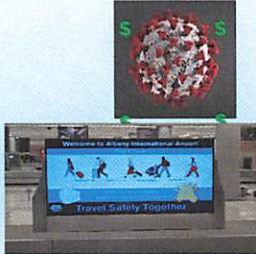

Albany
Westchester County
Airport
Albany, New York

PREPARING FOR RECOVERY



- Obtain FAA approval for allocating CARES Act Funding to payroll & debt service
- New signage & Terminal messaging On COVID-19 protocol
- Enhanced community messaging & updated website & social media



Albany
Westchester County
Airport
Albany, New York

PREPARING FOR RECOVERY



- Require passengers & staff to wear facial coverings In Terminal & Airport buildings
- Return to Work plans for all business at the Airport
- Installed social distancing ground markers throughout Terminal

Albany
Westchester County
Airport
Albany, New York

PREPARING FOR RECOVERY

- Worked with TSA on queuing protocols
- Installed plexiglass shields at contact points
- Installed UV light boxes on all escalators



PREPARING FOR RECOVERY

Installed high filtration screens on air handlers

Increased air flow to Terminal

Installed touchless time clocks for employees

Ground transportation document cleaning

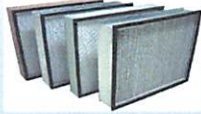



ALBANY COUNTY AIRPORT AUTHORITY
ALBANY INTERNATIONAL AIRPORT
ADMINISTRATION BUILDING
SUITE 200
ALBANY, NEW YORK 12211-1057

TEL: 518-242-2222
ADMIN FAX: 518-242-2641
FINANCE FAX: 518-242-2640
SITE: www.flyalbany.com

MEMO: June 8, 2020

TO: Albany County Airport Authority Board Members

FROM: Philip F. Calderone, Esq., Chief Executive Officer

Attached is the report of significant events for the period through May 31, 2020 as well as forward-looking, noteworthy items. If you have any questions regarding this report, please let me know.



ALBANY COUNTY AIRPORT AUTHORITY
ALBANY INTERNATIONAL AIRPORT
ADMINISTRATION BUILDING
SUITE 200
ALBANY, NEW YORK 12211-1057

TEL: 518-242-2222
ADMIN FAX: 518-242-2641
FINANCE FAX: 518-242-2640
SITE: www.flyalbany.com

CHIEF EXECUTIVE OFFICER'S JUNE 2020 REPORT

Pre-PAUSE (February)

- Convened Coronavirus Task Force (Authority staff, TSA, Air traffic control, Sheriff's Department, Chief Cook, Dr. Whalen, Dr. Dailey & Dr. Greenburg)
- Reviewed & implemented Disaster Preparedness Plans & Pandemic Preparedness Plans to assure safety of passengers, staff, construction teams & monitored CDC guidelines
- Worked with Air traffic control on a remote work plan for tower operations
- Worked with CyberWa and airport staff on a Disaster Preparedness Plan & security issues for remote work

The PAUSE (March & April)

- 97% reduction in traffic
- Took additional steps to assure the safety of passengers including installing hand sanitizer stations & distributed bottles of hand sanitizer lotion to passengers
- Implemented new safety protocols for cleaning (e.g. Purchasing CDC approved cleaning solutions & high intensity sprayers to spray, disinfect all surfaces in the Terminal, and installed new touchless time keeping systems for employees)
- Reached out to strategic partners (Unions, County, Sheriff, Airlines & Concessionaires) to communicate changes being made at the Airport
- Focused on adjusting 2020 budget (holding line on discretionary spending, limiting Capital expenditures, repurposing employees to perform previously outsourced services to avoid layoffs or furloughs, closed remote parking lots, closed parking garages, ended shuttle and valet services)
- Complied with Executive Orders on staffing (e.g. remote working for non-essential workers and those in high risk groups) and Operations (e.g. remote meeting on construction projects)
- Coordinated safety protocols for ongoing essential construction projects
- Lobbied for CARE Act funding
- Enhanced public messaging on the Airport's efforts to deal with the Coronavirus pandemic



ALBANY COUNTY AIRPORT AUTHORITY
ALBANY INTERNATIONAL AIRPORT
ADMINISTRATION BUILDING
SUITE 200
ALBANY, NEW YORK 12211-1057

TEL: 518-242-2222
ADMIN FAX: 518-242-2641
FINANCE FAX: 518-242-2640
SITE: www.flyalbany.com

CHIEF EXECUTIVE OFFICER'S JUNE 2020 REPORT

Preparing for the Recovery (May & June)

- Obtained FAA approval for allocating CARES Act funding to payroll & debt service
- New signage & Terminal messaging on COVID-19 protocol
- Enhanced community messaging & updated website & social media platforms
- Required passengers & staff to wear facial coverings in the Terminal and in all Airport buildings
- Worked on putting into place Return to Work plans for all businesses at the Airport
- Installed social distancing ground markers throughout the Terminal
- Worked with TSA on adequate queuing protocols
- Worked with all Airlines & tenants on installing plexiglass shields at all contact points
- Installed UV lights boxes on all Terminal escalators
- Installed high filtration screens on all air handlers & increased fresh airflow in the Terminal
- Applied antibacterial shields on door handles throughout the Terminal
- Installed new touchless Time clocks for employee time keeping
- Worked with ground transportation companies serving the Airport to ensure documented cleaning protocols are in place



ALBANY COUNTY AIRPORT AUTHORITY
ALBANY INTERNATIONAL AIRPORT
ADMINISTRATION BUILDING
SUITE 200
ALBANY, NEW YORK 12211-1057

TEL: 518-242-2222
ADMIN FAX: 518-242-2641
FINANCE FAX: 518-242-2640
SITE: www.flyalbany.com

CHIEF EXECUTIVE OFFICER'S JUNE 2020 REPORT

Moving Forward

- Exploring Touchless Technologies
- Establishing Critical Partnerships to explore & implement new technologies
 - GE
 - RPI
 - HVCC
- Moving forward with Master Plan & the Airport's role in Economic Development
- Working on AIA application for Future Capital Projects
- Working with Airlines on renewing Use & Lease Agreements
- Working with TSA & Airlines to ensure all steps are being taken to install confidence in the traveling public

AGENDA ITEM NO. 4

Interesting Correspondence

AGENDA ITEM NO. 5

Financials

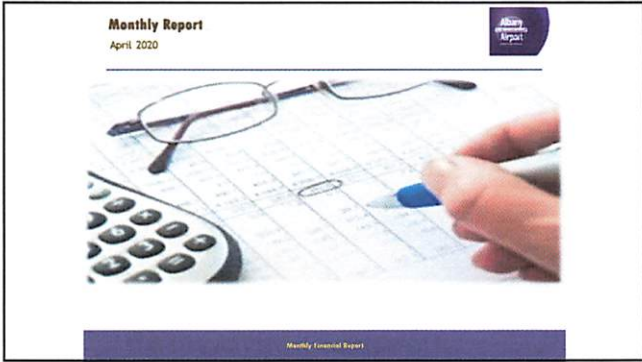

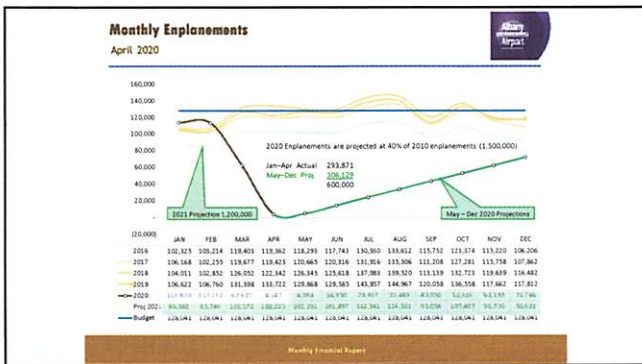

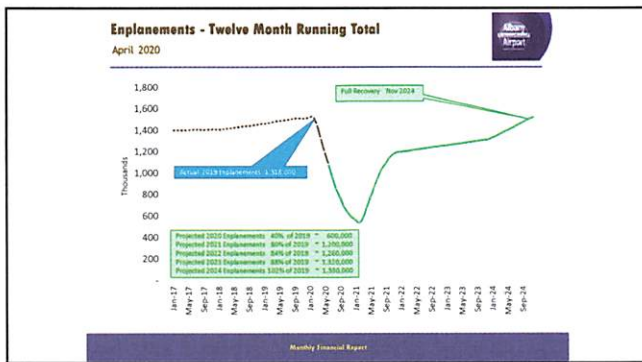

Monthly Scheduled Passenger Airline Service
April 2020



	Airlines	Non-Stop Originating Airports	Non-Stop Certificated Cities	Non-Stop Scheduled Flights	Average Flights per Day	Monthly Seats Available	Monthly Landed Weight
Jan20	7	17	13	1,391	44.9	141,803	147,829K
Feb20	7	16	12	1,374	47.4	141,833	147,219K
Mar20	7	18	14	1,549	50.0	161,752	162,630K
Apr20	7	17	13	891	30.0	109,200	102,522K
May20	7	12	10	418	13.5	49,913	45,124K
Jun20	7	15	12	556	18.5	65,955	65,335K

Monthly Financial Report

Monthly Report



THANK YOU

Monthly Financial Report



June 2, 2020

ACAA Members

INTRODUCTION

The COVID -19 pandemic had a devastating effect on the Albany County Airport Authority’s (“ACAA”) April 2020 financial and statistical results as shown below:

	<u>Current Year versus</u>			
	<u>2020</u>	<u>2019</u>	<u>2019</u>	<u>2019</u>
	<u>Budget</u>	<u>Month</u>	<u>YTD</u>	<u>Prev.</u>
	<u>12 Mo.</u>			
Enplanements	(96.8%)	(96.9%)	(38.5%)	(10.4%)
Cargo	2.7	1.4	(8.8)	9.8
Operations	(60.1)	(59.0)	(20.2)	(9.3)
Landed Weight	(71.0)	(71.0)	(21.2)	(5.3)

	<u>Month</u>	
	<u>2019</u>	<u>2020</u>
Average Daily Flights	58	18.5
Seat Capacity	167,206	118,798
Load Factor	80.0%	3.5%

FINANCIAL INFORMATION

Cash Position – Unrestricted (Operating)

Despite the unfavorable above results, the Airport continues to have a strong cash position. The Statements of Net Position provided on Page 3 reports unrestricted cash of \$27,261,979. This unrestricted cash balance equates to approximately 7.1 months of operating reserves (Notes to Financial Statements #2, Page 11), this is a 0.5 month decrease from the prior month.

Cash Position – Restricted

Restricted cash available for capital purposes is as follows:

Cash	\$ 4,688,273
Receivables	<u>8,077,376</u>
	\$12,765,649

Accounts Receivable

The Accounts Receivable balance is approximately 10.91 of average day total operating revenues.

Equity – YTD Earnings

The Summary of Revenues, Expenses and Net results is provided on Page 4. As shown, the Airport has an increase in net position of \$1,881,039 and \$6,035,202 for the month and year-to-date, respectively, itemized as follows:

	<u>Month</u>	<u>YTD</u>
Airport Operating	(\$ 671,295)	\$2,150,085
FBO Profit	<u>(19,635)</u>	<u>336,825</u>
	(690,930)	2,486,910
Other Rev/Exp (d.ser.)	(693,589)	(2,835,185)
Capital Contributions	3,331,433	6,678,664
Airline Incnt. Payts.	<u>(65,886)</u>	<u>(295,187)</u>
	<u>2,571,958</u>	<u>3,548,292</u>
	\$1,881,0281	\$6,035,202

As shown above, the results would have been materially different had Capital Contributions not been included in the calculation.

Operating Revenues

Monthly operating revenues were approximately \$1,506K and \$3,961K for 2020 and 2019, respectively, a difference of \$2,455K. Most of this decrease is attributable to a \$1,560K loss in Parking Revenue. YTD operating revenues were approximately \$12,121K and \$15,071K for 2020 and 2019, respectively. This \$2,950K decrease is likewise attributed to a decrease in parking operations.

Operating Expenses

Monthly operating expenses were approximately \$2,177K and \$2,259 for 2020 and 2019, respectively. YTD operating expenses were \$9,971K and \$10,045K for 2020 and 2019 respectively. The differences in both periods are less than 3 percent.

ALBANY COUNTY AIRPORT AUTHORITY

Monthly Financial Report

April 2020

Table of Contents

Transmittal Letter	1
Financial Report	
Statement of Net Position	3
Summary of Revenues, Expenses and Net Results	4
Schedule of Operating Revenues	5
Schedule of Operating Expenses	6
FBO Summary of Revenues, Expenses and Net Results	10
Notes to Financial Statements	11
Schedule of Statistics	12
Schedule of Scheduled Passenger Airline Services	13



June 2, 2020

ACAA Members

INTRODUCTION

The COVID -19 pandemic had a devastating effect on the Albany County Airport Authority’s (“ACAA”) April 2020 financial and statistical results as shown below:

	<u>Current Year versus</u>			
	<u>2020</u> Budget	<u>2019</u> Month	<u>2019</u> YTD	<u>2019</u> Prev. 12 Mo.
Enplanements	(96.8%)	(96.9%)	(38.5%)	(10.4%)
Cargo	2.7	1.4	(8.8)	9.8
Operations	(60.1)	(59.0)	(20.2)	(9.3)
Landed Weight	(71.0)	(71.0)	(21.2)	(5.3)

	<u>Month</u>	
	<u>2019</u>	<u>2020</u>
Average Daily Flights	58	18.5
Seat Capacity	167,206	118,798
Load Factor	80.0%	3.5%

FINANCIAL INFORMATION

Cash Position – Unrestricted (Operating)

Despite the unfavorable above results, the Airport continues to have a strong cash position. The Statements of Net Position provided on Page 3 reports unrestricted cash of \$27,261,979. This unrestricted cash balance equates to approximately 7.1 months of operating reserves (Notes to Financial Statements #2, Page 11), this is a 0.5 month decrease from the prior month.

Cash Position – Restricted

Restricted cash available for capital purposes is as follows:

Cash	\$ 4,688,273
Receivables	<u>8,077,376</u>
	\$12,765,649

Accounts Receivable

The Accounts Receivable balance is approximately 10.91 of average day total operating revenues.

Equity – YTD Earnings

The Summary of Revenues, Expenses and Net results is provided on Page 4. As shown, the Airport has an increase in net position of \$1,881,039 and \$6,035,202 for the month and year-to-date, respectively, itemized as follows:

	Month	YTD
Airport Operating	(\$ 671,295)	\$2,150,085
FBO Profit	<u>(19,635)</u>	<u>336,825</u>
	(690,930)	2,486,910
Other Rev/Exp (d.ser.)	(693,589)	(2,835,185)
Capital Contributions	3,331,433	6,678,664
Airline Incnt. Payts.	<u>(65,886)</u>	<u>(295,187)</u>
	<u>2,571,958</u>	<u>3,548,292</u>
	\$1,881,0281	\$6,035,202

As shown above, the results would have been materially different had Capital Contributions not been included in the calculation.

Operating Revenues

Monthly operating revenues were approximately \$1,506K and \$3,961K for 2020 and 2019, respectively, a difference of \$2,455K. Most of this decrease is attributable to a \$1,560K loss in Parking Revenue. YTD operating revenues were approximately \$12,121K and \$15,071K for 2020 and 2019, respectively. This \$2,950K decrease is likewise attributed to a decrease in parking operations.

Operating Expenses

Monthly operating expenses were approximately \$2,177K and \$2,259 for 2020 and 2019, respectively. YTD operating expenses were \$9,971K and \$10,045K for 2020 and 2019 respectively. The differences in both periods are less than 3 percent.

BUDGET

Monthly operating revenues were unfavorable by approximately \$2,305K, again, due in large part to the decrease in parking revenue. On a pleasant note, monthly operating expenses were favorable by approximately \$222K due to cost saving measures enacted as a result of COVID-19.

YTD operating revenues were unfavorable by approximately \$2,382K. YTD operating expense were favorable by approximately \$756K.

MILLION AIR FBO OPERATIONS

Revenues derived from the sale of JetA and AvGas fuels, is the largest contributor of FBO revenue. Below is the decrease of the fuel sold in gallons as a result of decreased operations attributed to the COVID-19 pandemic.

	<u>Current Year versus</u>			
	2020	2019	2019	2019
	Budget	Month	YTD	Prev.
				<u>12 Mo.</u>
JetA (gals)	(38.7%)	(31.3%)	(18.4%)	(4.0%)
AvGas (gals)	(38.9)	(29.4)	(.5)	21.9

The FBO Summary of Revenues, Expenses and Net results are shown on Page 4.

Operating Profits for YTD 2020 are \$20,433 lower and \$282,109 lower than budget and the previous year, respectively.

Commercial AvGas Fuel Sales has decreased substantially from the prior year due to Cape Air leaving the Boston and Ogdensburg markets.

Albany County Airport Authority
Statements of Net Position

	Unaudited April 30, 2019	Unaudited April 30, 2020
<u>ASSETS</u>		
CURRENT ASSETS		
Unrestricted Assets		
Cash and cash equivalents	\$28,890,485	\$27,261,979
Accounts receivable - net	1,258,704	1,366,345
Prepaid Expenses	658,804	460,318
Total Unrestricted Assets	30,807,993	29,088,642
Restricted Assets		
CFC Funds	--	448,023
Capital Funds	23,227,335	12,765,649
PFC Funds	14,040,308	16,747,183
Revenue Bond Funds	15,230,893	11,773,756
Refunding Bonds Escrow	1,475,000	44,825,991
FAA Restricted Funds	1,067,062	203,208
Concession Improvement Funds	798,041	696,656
Total Restricted Assets	55,838,639	87,460,465
Total Current Assets	86,646,632	116,549,107
NON-CURRENT ASSETS		
Bond Insurance Premiums	280,784	227,192
Capital Assets	241,512,737	289,765,955
Prepaid Expenses	--	225,103
Total Non-Current Assets	241,793,521	290,218,251
Total Assets	328,440,153	406,767,358
<u>DEFERRED OUTFLOWS OF RESOURCES</u>		
Refunding	3,031,914	2,145,790
OPEB Expenses	34,725	621,658
Pension Expenses	782,773	541,970
Total Deferred Outflows of Resources	3,849,412	3,309,418
TOTAL ASSETS AND DEFERRED OUTFLOWS	332,289,565	410,076,776
<u>LIABILITIES AND NET ASSETS</u>		
CURRENT LIABILITIES		
Payable from Unrestricted Assets	5,442,037	6,849,117
Payable from Restricted Assets	5,465,254	18,879,266
Total Current Liabilities	10,907,291	25,728,383
NON-CURRENT LIABILITIES		
Bonds and other debt obligations	94,230,495	128,767,876
Net OPEB liability	6,686,550	7,680,692
Net pension liability - proportionate share	238,153	407,198
Total Non-Current Liabilities	101,155,198	136,855,766
Total Liabilities	112,062,489	162,584,149
<u>DEFERRED INFLOWS OF RESOURCES</u>		
Concession Improvement Funds	888,499	700,260
OPEB expenses	64,289	48,217
Pension expenses	492,514	119,207
Total Deferred Inflows of Resources	1,445,302	867,684
<u>NET POSITION</u>		
Invested in Capital Assets, net of Related Debt	169,998,434	159,049,281
Restricted	29,940,946	72,034,254
Unrestricted	18,842,393	15,541,408
Net Position	218,781,774	246,624,943
TOTAL LIABILITIES, DEFERRED INFLOWS AND NET POSITION		
	332,289,565	410,076,776

Albany County Airport Authority
2020 Summary of Revenues, Expenses and Net Results
For the four months ended April 30, 2020

	Current Month			Year to Date		
	2020 Budget	2019 Actual	2020 Actual	2020 Budget	2019 Actual	2020 Actual
AIRPORT						
OPERATING REVENUES						
Airline	\$ 1,135,502	\$ 1,191,712	\$ 835,716	\$ 4,544,824	\$ 4,786,088	\$ 4,219,992
Non-Airline	2,676,485	2,768,826	670,545	9,959,879	10,285,737	7,901,859
Total Revenues	3,811,987	3,960,538	1,506,261	14,504,703	15,071,825	12,121,851
OPERATING EXPENSES						
Personal Services	786,193	744,432	682,407	3,373,455	3,103,861	3,002,410
Employee Benefits	450,151	396,801	398,454	1,831,023	1,617,919	1,680,598
Utilities & Communications	162,033	182,847	182,338	880,751	835,578	840,967
Purchased Services	511,729	483,904	465,356	2,453,793	2,408,393	2,364,338
Material & Supplies	380,525	343,098	344,665	1,742,420	1,694,568	1,549,433
Office	31,867	20,360	66,341	162,449	116,988	290,878
Administration	77,486	87,747	37,995	281,228	268,214	243,142
Total Expenses	2,399,984	2,259,189	2,177,556	10,725,119	10,045,521	9,971,766
AIRPORT OPERATING RESULTS	1,412,003	1,701,349	(671,295)	3,779,584	5,026,304	2,150,085
FBO OPERATING RESULTS	64,132	80,357	(19,635)	357,258	618,934	336,825
TOTAL OPERATING RESULTS	1,476,135	1,781,706	(690,930)	4,136,842	5,645,238	2,486,910
OTHER REVENUES (EXPENSES)						
Interest Earnings	77,322	134,449	11,539	309,288	506,348	223,041
Passenger Facility Charges	345,076	376,345	345,076	1,380,306	1,505,380	1,380,306
ACAA Debt Service	(920,797)	(993,368)	(1,089,954)	(3,683,184)	(3,973,472)	(4,514,187)
Line of Credit Interest	-	-	(2,350)	-	(2,187)	(33,467)
Non-Capital Equipment	(32,917)	(113,753)	-	(131,669)	(169,154)	(47,878)
Insurance Recoveries	-	-	-	-	8,704	-
Customer Facility Charges Income	-	131,374	-	-	186,056	-
Customer Facility Charges Expense	-	(2,000)	-	-	(309,457)	-
Grant Income	9,967	11,400	11,400	58,750	45,600	34,200
Improvement Charges	30,700	30,700	30,700	122,800	122,800	122,800
Total Other Revenues(Expenses)	(490,649)	(424,853)	(693,589)	(1,943,709)	(2,079,382)	(2,835,185)
INCOME/(LOSS) BEFORE CAPITAL CONTRIBUTIONS	985,486	1,356,853	(1,384,519)	2,193,133	3,565,856	(348,275)
AIRLINE INCENTIVES		(164,009)	(65,886)		(448,725)	(295,187)
CAPITAL CONTRIBUTIONS		941,929	3,331,433		1,094,983	6,678,664
INCREASE IN NET POSITION		\$ 2,134,773	\$ 1,881,028		4,212,114	6,035,202
NET POSITION, BEGINNING OF PERIOD					214,569,660	240,589,741
NET POSITION, END OF PERIOD					\$ 218,781,774	\$ 246,624,943
RECONCIATION TO AIRLINE FUNDS REMAINING:						
NET RESULTS BEFORE RESERVES	985,486	1,356,853	(1,384,519)	2,193,133	3,565,856	(348,275)
Less: Capital Improvements	(275,956)	(275,511)	(275,956)	(1,103,822)	(1,102,045)	(1,103,822)
Less: Reserve Requirements	(10,473)	(36,323)	(10,473)	(41,893)	(145,293)	(41,893)
NET RESULTS	699,057	1,045,019	(1,670,948)	1,047,417	2,318,518	(1,493,991)
Revenue Sharing:						
Transfer to/from Airlines (50%)	349,529	522,509	(835,474)	523,709	1,159,259	(746,995)
Authority Share (50%)	349,529	522,509	(835,474)	523,709	1,159,259	(746,995)
Less: Airline Incentives	(83,333)	(164,009)	(65,886)	(83,333)	(448,725)	(295,187)
Net Authority Share	\$ 266,195	\$ 358,500	\$ (901,360)	\$ 440,375	\$ 710,534	\$ (1,042,182)

Albany County Airport Authority
Operating Revenues
For the four months ended April 30, 2020

	Current Month			Year to Date		
	2020 Budget	2019 Actual	2020 Actual	2020 Budget	2019 Actual	2020 Actual
AIRLINE REVENUES						
COMMERCIAL						
Landing Fees	\$ 454,814	\$ 497,383	\$ 132,110	\$ 1,647,166	\$ 1,803,874	\$ 1,294,799
Airline Apron Fees	56,674	67,457	74,762	226,694	267,131	258,084
Glycol Disposal Fee	13,806	8,931	3,508	223,407	238,777	169,096
CARGO						
Landing Fee	39,893	44,675	41,609	166,295	183,242	163,102
TERMINAL						
Loading Bridges	55,336	57,643	59,592	221,343	230,571	238,368
Space Rental	514,980	515,623	524,136	2,059,920	2,062,493	2,096,543
TOTAL AIRLINE REVENUES	1,135,502	1,191,712	835,716	4,544,824	4,786,088	4,219,992
NON-AIRLINE REVENUES						
AIRFIELD						
Tenant Maintenance	779	985	0	20,159	26,986	7,810
Total Airfield	779	985	0	20,159	26,986	7,810
TERMINAL						
Utility Reimbursement	1,852	1,734	1,732	8,548	8,141	8,115
Tenant Maintenance	572	1,047	1,047	2,462	(624)	22,428
Space Rent - Non Airline	61,638	60,917	60,955	246,554	244,192	244,427
Food & Beverage	82,276	106,136	49,584	303,132	391,038	310,614
Retail	79,781	88,164	14,379	269,619	293,677	173,566
Advertising	25,000	20,985	8,919	100,000	104,537	70,299
Foreign Currency Concession	0	2,217	0	0	8,867	0
Payphones	190	109	18	759	473	194
ATM	2,965	3,301	2,547	11,859	11,558	10,822
Museum Shop	0	13,689	0	0	55,922	0
Operating Permits	18,181	24,499	4,615	65,319	86,965	75,984
Vending Machines	2,372	2,400	(143)	10,068	10,088	7,273
Baggage Cart Rentals	1,383	1,200	322	5,531	3,870	2,773
Total Terminal	276,209	326,396	143,974	1,023,852	1,218,704	926,494
GROUND TRANSPORTATION						
Parking	1,619,411	1,609,555	49,678	5,913,734	5,837,153	3,888,230
Rental Cars	322,740	316,211	71,176	1,108,711	1,126,032	996,140
Access Fees	30,507	33,107	67	142,314	144,493	81,188
TNCs	22,055	26,720	1,772	83,133	100,718	81,249
Garage Space Rent	7,708	7,708	8,123	30,831	30,210	30,477
Total Ground Transportation	2,002,420	1,993,301	130,816	7,278,722	7,238,606	5,077,283
OTHER AIRPORT						
Telephone System - Tenants	5,833	5,739	4,844	23,333	23,410	23,644
Building Rental	8,451	8,927	8,338	56,761	53,360	56,003
Control Tower Rental	55,481	55,481	55,481	221,925	221,925	221,925
Air Cargo Facility	39,005	78,010	42,947	156,020	312,039	184,209
State Executive Hangar	103,924	103,924	103,924	415,694	415,694	415,694
T Hangars	8,361	8,820	11,208	33,443	34,549	43,111
Tie Downs	355	355	241	1,419	1,419	964
AV Gas Fuel Sales	2,958	1,515	3,395	9,757	6,873	13,647
Industrial Park	48,170	46,470	47,381	192,679	187,211	189,362
Land Rental	26,278	26,167	23,625	105,347	114,665	99,938
Eclipse Hangar	27,806	27,700	28,279	111,225	110,801	113,117
Hangar Rental	42,848	42,356	43,356	171,390	169,423	173,424
Internet and Cable Access	1,040	1,040	985	2,960	2,960	2,795
Fingerprinting	2,500	4,398	1,345	10,000	11,680	9,746
Tenant Maintenance	83	0	0	333	889	0
Purchasing Proposals	83	0	0	333	450	75
Ebay/Scrap/Equipment Sales	1,250	10	295	5,000	2,006	1,508
Utility Reimbursement	15,984	18,219	18,501	77,121	83,173	71,243
Reim of Property Taxes	0	0	0	15,736	17,189	18,128
Other	6,667	19,013	1,611	26,667	31,724	251,738
Total Other Airport	397,077	448,144	395,755	1,637,145	1,801,440	1,890,272
TOTAL NON AIRLINE REVENUES	2,676,485	2,768,826	670,545	9,959,879	10,285,737	7,901,859
TOTAL REVENUES	\$ 3,811,988	\$ 3,960,538	\$ 1,506,261	\$ 14,504,703	\$ 15,071,825	\$ 12,121,851

Albany County Airport Authority
Operating Expenses
For the four months ended April 30, 2020

	Current Month			Year to Date		
	2020 Budget	2019 Actual	2020 Actual	2020 Budget	2019 Actual	2020 Actual
PERSONAL SERVICES						
Salaries	\$ 725,912	\$ 667,752	\$ 655,944	\$ 3,044,291	\$ 2,703,410	\$ 2,733,671
Overtime 1.5	56,191	72,548	25,733	302,207	354,650	240,804
Overtime 2.0	3,257	4,132	730	23,623	30,806	16,873
Temporary Help	833	0	0	3,333	14,996	11,062
Total Personal Services	786,193	744,432	682,407	3,373,455	3,103,861	3,002,410
EMPLOYEE BENEFITS						
Social Security	65,990	55,494	50,729	253,543	229,844	222,929
Health Insurance	238,760	217,849	218,164	955,041	868,008	897,649
OPEB	34,314	27,083	34,314	137,257	108,333	137,257
Health-Dental	3,595	3,424	3,590	14,380	13,695	14,829
Health-Vision	522	516	557	2,090	2,065	2,099
Health - AFLAC	600	606	(645)	2,400	2,379	1,127
Medical Exams	1,550	640	229	6,200	5,556	6,651
EAP Program	0	0	0	613	613	0
Smoking Cessation Class	100	0	0	400	0	0
Uniforms & Laundry	4,392	4,446	3,663	17,567	15,089	15,046
Uniform Purchases	3,067	1,682	2,707	12,267	4,642	14,886
Disability Insurance	11,193	17,343	17,784	47,559	56,347	55,270
Unemployment Insurance	3,015	2,204	1,605	51,753	43,684	39,951
Workers Compensation	46,178	30,072	30,083	184,711	122,959	123,481
NYS Retirement	21,065	21,682	23,529	84,261	86,728	94,117
Airport & FBO 401K	15,810	13,759	12,145	60,983	57,977	55,306
Total Employee Benefits	450,151	396,801	398,454	1,831,023	1,617,919	1,680,598
UTILITIES & COMMUNICATIONS						
Electric	116,396	145,787	140,710	518,010	501,409	527,024
Natural Gas	32,102	29,040	28,512	153,127	146,149	107,956
Sewer	0	0	0	91,400	79,331	91,820
Water	0	0	0	64,075	62,742	61,383
Telephone Charges-Local	1,579	1,582	1,486	6,317	6,184	5,922
Tele Chg-Long Dist	560	250	1,543	2,242	733	3,022
Telephone - Sheriff	335	334	344	1,342	1,332	1,352
Telephones-Monthly Service	1,167	0	1,236	4,667	3,701	4,954
Telephones-Monthly Usage	250	1,336	23	1,000	1,662	101
Payphones-Annual & Mo Serv	1,042	1,439	1,442	4,167	4,082	4,095
Payphones-Monthly Usage	25	19	9	100	82	39
Telephone Repairs	1,750	(1,945)	245	7,000	10,580	3,428
Telephone-Cellular	3,667	3,571	3,975	14,667	11,314	20,093
Internet Access	2,937	1,437	2,812	11,749	5,748	9,898
Cable Television	223	0	0	890	527	(119)
Total Utilities & Communications	162,033	182,847	182,338	880,751	835,578	840,967
PURCHASED SERVICES						
Accounting & Auditing						
Financial Services	6,958	(140)	40,690	34,285	76,184	75,817
Rates & Charges	6,000	5,322	6,000	6,000	5,322	6,000
Total Accounting & Auditing	12,958	5,182	46,690	40,285	81,506	81,817
Insurance						
Airport Liability Insurance	499	970	485	235,999	229,121	255,576
Automotive Insurance	7,294	6,333	6,350	42,902	45,396	43,708
Environmental Liability	0	0	0	39,866	38,705	35,350
Property Insurance	22,139	18,705	19,573	131,697	132,762	140,389
Crime Insurance	0	0	0	6,774	6,577	6,604
Fiduciary Insurance	0	0	0	0	0	14,209
Public Official Liability	0	0	0	25,813	25,061	39,615
Cyber Liability	0	0	0	16,644	5,073	0
Agency Fee	0	0	0	30,000	30,000	30,000
Insurance Claims	1,292	0	0	5,167	2,461	0
Total Insurance	31,224	26,008	26,408	534,862	515,156	565,451

Albany County Airport Authority
Operating Expenses
For the four months ended April 30, 2020

	Current Month			Year to Date		
	2020 Budget	2019 Actual	2020 Actual	2020 Budget	2019 Actual	2020 Actual
Legal						
Legal Services	8,333	2,418	0	33,333	4,909	0
Total Legal	8,333	2,418	0	33,333	4,909	0
Public Safety						
Public Safety	233,233	227,655	233,233	932,932	910,620	932,932
Outside Security Services	26,385	6,394	10,438	112,135	86,866	101,562
Armored Car Service	750	740	804	3,000	2,952	3,262
Parking Valet Service	44,544	41,238	25,020	164,033	160,420	113,226
Employee Shuttle Service	0	0	0	15,000	15,000	0
Ground Transportation	0	19,880	0	0	19,880	0
Total Public Safety	304,911	295,907	269,495	1,227,100	1,195,738	1,150,983
Janitorial						
Janitorial Services	43,069	40,153	45,701	172,276	158,073	157,442
Refuse Removal Services	5,677	6,539	3,252	22,707	24,498	21,052
Total Janitorial	48,746	46,691	48,954	194,983	182,571	178,494
Public Communications						
Public Relations	8,542	8,159	1,844	34,167	39,814	30,461
Artistic Exhibits	8,395	4,418	2,255	34,585	38,946	30,203
Museum Shop	0	21,018	156	0	74,375	626
Advertising	16,667	10,739	0	66,667	21,484	18,338
Passenger Information Booth	12,859	12,594	12,846	51,434	50,376	51,385
Total Public Communications	46,461	56,927	17,102	186,852	224,995	131,013
Studies						
Special Studies	4,750	0	2,500	19,000	0	9,990
GIS Services	1,017	0	3,424	4,067	2,992	6,164
Total Studies	5,767	0	5,924	23,067	2,992	16,155
Professional Services						
Appraisal	417	0	0	1,667	0	0
Architectural	5,833	0	0	23,333	(7)	0
Consultant	4,167	8,469	5,684	16,667	15,688	50,167
Engineering Services	3,000	3,121	0	12,000	29,374	9,860
Professional Management	35,417	35,417	35,417	141,667	140,417	141,667
Code Enforcement	4,495	3,763	9,683	17,979	15,053	38,733
Total Professional Services	53,328	50,770	50,784	213,312	200,525	240,427
Total Purchased Services	511,729	483,904	465,356	2,453,793	2,408,393	2,364,338
MATERIALS & SUPPLIES						
Airfield						
Fencing	178	0	775	2,678	1,944	2,453
Airfield Lighting	16,561	8,657	6,891	46,235	15,543	64,538
Pavement Repairs	108	0	0	125	83	0
Apron Maintenance	1	0	0	2,572	18	45,244
Runway Painting	0	0	0	691	0	0
Airfield Shop Supplies	2,083	4,167	589	8,333	6,896	4,360
Snow Removal Supplies	5,790	0	0	153,516	140,259	69,580
Rubber Removal	0	0	19,104	3,872	0	19,104
EMS Supplies	1,000	2,190	0	4,000	2,190	0
ARFF Supplies	2,083	254	1,134	8,333	2,030	12,950
Hazardous Material Supplies	500	0	0	2,000	0	760
Foam	2,000	0	0	8,000	0	0
Wastewater Conveyance	7,500	7,500	0	7,500	7,500	0
Electric	13,412	11,727	10,910	56,785	42,313	48,185
Sewer District Charges	0	0	0	5,000	0	0
Water District Charges	3,630	2,353	1,771	14,397	17,917	6,200
System Maint & Repairs	13,844	12,090	10,374	50,103	39,905	47,712
Total Airfield	68,692	48,938	51,548	374,140	276,598	321,086

Albany County Airport Authority
Operating Expenses
For the four months ended April 30, 2020

	Current Month			Year to Date		
	2020 Budget	2019 Actual	2020 Actual	2020 Budget	2019 Actual	2020 Actual
Buildings						
Alarm & PA Systems	9,042	16,031	0	36,167	28,224	18,817
Card Access Control	6,250	194	5,935	25,000	18,480	9,966
CTV Repair	3,333	326	8,288	13,333	13,711	8,746
Key Access System	2,083	4,390	0	8,333	4,246	1,977
Baggage System	2,083	0	0	8,333	77,299	0
Electrical Repairs & Supplies	21,000	20,100	22,635	84,000	78,982	137,444
Elevator Repairs & Supplies	10,708	50,611	5,636	42,833	51,900	40,007
HVAC	18,591	20,231	5,575	79,139	86,292	64,362
Roof	2,375	977	868	9,500	2,725	7,222
Plumbing Repairs & Supplies	7,917	4,301	9,115	31,667	46,379	34,972
Automatic Door Repairs	792	681	0	3,167	1,873	258
Pest Control	2,441	2,481	23,897	9,765	8,834	33,201
Services	0	0	0	0	7,542	0
Fire Equipment Services	417	1,341	1,131	1,667	1,341	1,237
Fire Equipment Testing	333	0	0	1,333	89	1,259
US Customs	5,445	1,234	46	7,506	1,790	414
Control Tower	25,000	18,968	19,893	100,000	99,531	104,912
Storage Space Rental	625	0	1,093	2,500	1,703	3,030
Building Maintenance	51,458	58,587	92,502	205,833	208,226	296,307
Janitorial Supplies	13,583	12,847	24,922	54,333	45,784	77,672
Window Washing	5,969	0	4,996	23,876	67	14,987
ID Tags	2,917	3,238	4,860	11,667	8,816	7,305
Sign Expense	417	1,218	0	1,667	2,438	1,700
Flight Information Displays	8,045	0	0	32,181	2,787	8,371
Total Buildings	200,825	217,756	231,393	793,801	799,059	874,165
Grounds						
Landscaping	3,217	383	0	3,228	383	680
Fencing	125	0	0	500	14,264	0
Pavement Repairs	3,217	4,282	325	5,662	26,958	56,710
Utility Repairs	42	0	0	167	0	0
Sign Expense	1,250	1,275	10,396	5,000	3,213	16,224
Traffic Light Repairs	167	0	0	667	0	0
Catch Basin Maintenance	250	0	0	1,000	0	0
Snow Removal Supplies	0	0	0	19,566	0	27,420
Snow Removal Services	26,192	0	0	205,845	262,644	24,559
NYS Police Hangar Maint	10,417	11,449	6,917	41,667	67,044	23,197
Dump Fees - Landfill	763	612	0	3,050	1,462	604
Hazardous Waste Mgmt	425	0	525	1,700	600	525
Wildlife Hazard Management	3,167	3,727	1,622	12,667	19,201	7,736
Liquid Waste Disposal	2,500	0	0	10,000	0	1
Land Lease	2,411	16,286	1,286	9,645	26,145	5,145
T-Hangar Facility Maintenance	6,648	4,876	17,027	32,648	29,929	46,751
Total Grounds	60,788	42,891	38,099	353,009	451,845	209,553
Vehicles						
Gasoline	4,891	3,742	1,572	20,249	18,794	14,506
Diesel Fuel	5,365	3,395	4,703	61,547	61,618	31,314
Oil / Grease	2,333	192	1,750	9,333	568	3,452
CNG Fuel	2,324	1,936	1,362	8,178	6,568	7,084
Vehicle / Equipment Tires	3,583	1,030	229	14,333	7,079	33,781
Vehicle Repair & Maintenance	6,000	11,793	3,975	24,000	21,520	11,684
Vehicle Communication Equip	583	69	0	2,333	69	641
Sheriff Vehicle Repair & Maint	0	0	0	0	0	(53)
General Equip Repair & Maint	4,092	1,148	3,170	16,367	6,935	10,625
Heavy Equipment Maint	5,000	1,073	947	20,000	9,433	5,015
ARFF Vehicle Repair & Maint	1,667	566	563	6,667	4,515	3,214
Snow Equip Repair & Maint	9,067	2,648	217	19,627	11,635	7,441
Mower Repair & Maintenance	1,148	1,208	2,894	2,169	3,032	4,309
Vehicle Shop Tools & Supplies	4,167	4,714	2,244	16,667	15,301	11,615
Total Vehicles	50,220	33,514	23,625	221,470	167,067	144,628
Total Material & Supplies	380,525	343,098	344,665	1,742,420	1,694,568	1,549,433

Albany County Airport Authority
Operating Expenses
For the four months ended April 30, 2020

	Current Month			Year to Date		
	2020 Budget	2019 Actual	2020 Actual	2020 Budget	2019 Actual	2020 Actual
OFFICE						
Office Equipment Rental	1,403	2,350	1,550	5,611	5,089	6,110
Copy Machine Use	83	243	952	333	243	952
Office Equipment Serv Agrmnt	861	610	699	2,468	2,292	2,730
Office Equipment Repairs	67	0	0	267	0	0
Computer System Supplies	4,588	(1,449)	1,342	18,350	6,251	26,556
Hardware/Software Maint	10,489	7,153	50,541	81,271	55,907	178,181
Computer Equipment	2,135	840	2,658	8,540	5,278	39,191
Office Furniture & Fixtures	1,596	368	300	6,383	875	4,510
Printed Forms / Letterhead	392	0	1,091	1,567	103	1,104
Parking Ticket Stock	1,333	0	0	5,333	5,647	4,244
Printing Outside Services	1,675	677	681	6,700	9,838	1,704
Postage	708	(162)	1,500	2,833	3,789	4,151
Express Mail	108	152	45	433	298	(82)
Reference Materials	233	736	255	933	736	255
Office Supplies	2,408	3,028	634	9,633	9,220	7,002
Payroll Services	3,787	5,816	4,093	11,792	11,423	14,269
Total Office	31,867	20,360	66,341	162,449	116,988	290,878
ADMINISTRATION						
Dues & Subscriptions	1,522	1,120	602	13,036	10,783	7,913
Airport Membership (ACI)	0	0	0	14,500	14,217	14,787
A.A.A.E. Memberships	325	275	0	1,200	825	275
G.F.O.A.	0	0	0	290	780	0
NYS Bar Association	0	0	0	0	0	145
NY Airport Managers Assoc	5,000	8,000	0	5,000	8,000	5,000
Local Chamber Of Commerce	3,056	3,700	4,000	3,751	4,568	4,175
AvPorts/MA Training & Travel	10,151	19,867	1,239	31,791	29,082	16,064
Authority Travel & Education	42	0	0	167	0	0
Authority Mgmt Travel & Educ	1,891	1,007	1,942	5,821	4,343	3,494
Function Refreshments	1,465	1,217	190	5,183	4,333	2,264
Outside Functions	417	0	0	1,667	2,828	2,700
Tuition Reimbursement	208	0	0	833	0	0
Advertising - Public Meetings	2,250	865	1,432	9,000	8,229	5,049
Economic Development	917	0	0	3,667	0	0
Property Taxes	0	0	0	11,314	11,224	11,367
Credit Card Service Charges	37,124	37,117	28,528	126,765	124,452	139,397
EZ Pass Fees	12,286	12,636	0	43,910	41,442	28,451
Bank & Paying Agent Fees	833	1,943	63	3,333	3,109	2,063
Total Administration	77,486	87,747	37,995	281,228	268,214	243,142
TOTAL EXPENSES	\$ 2,399,984	\$ 2,259,190	\$ 2,177,556	\$ 10,725,119	\$ 10,045,520	\$ 9,971,766

Albany County Airport Authority
FBO Results
For the four months ended April 30, 2020

	Current Month			Year to Date		
	2020 Budget	2019 Actual	2020 Actual	2020 Budget	2019 Actual	2020 Actual
OPERATING REVENUES						
Retail Fuel						
Jet A Fuel Sales	\$ 381,590	\$ 336,176	\$ 167,526	\$ 1,584,196	\$ 1,568,963	\$ 1,145,410
AvGas Fuel Sales	25,555	23,186	11,919	78,624	74,232	67,548
Commercial AvGas Fuel Sales	1,965	33,237	512	7,860	117,426	4,463
Auto & Diesel Fuel Sales	19,983	21,351	7,761	143,858	143,164	94,087
Retail Fuel Sales	429,093	413,950	187,719	1,814,539	1,903,785	1,311,508
Into Plane Fees	57,418	60,055	18,580	211,447	222,840	173,235
Fuel Farm Fees	55,194	57,753	11,329	216,682	215,721	165,719
General Aviation Landing Fees	20,772	21,197	5,063	74,944	74,191	54,593
Aircraft Parking Fees	14,911	11,831	4,866	49,331	42,125	40,120
Deicing Services	51,246	41,136	10,269	796,553	1,020,911	667,922
FBO Properties	24,493	25,656	28,628	139,015	121,749	130,176
FBO Services	4,989	10,917	2,710	19,907	32,540	26,408
TOTAL REVENUES	658,116	642,494	269,164	3,322,418	3,633,863	2,569,681
COST OF SALES						
Fuel Costs - Jet A	219,556	194,256	61,278	911,502	897,396	581,971
Fuel Discounts - Jet A	25,571	24,234	20,316	106,161	110,757	97,231
Fuel Costs - AvGas	19,153	19,188	8,105	58,929	60,113	52,639
Fuel Discounts - AvGas	353	276	125	1,088	1,036	1,135
Fuel Costs - Commercial AvGas	1,576	29,740	631	6,504	104,177	4,405
Fuel Costs - Auto & Diesel	14,978	16,829	7,637	119,408	107,740	68,282
Total Fuel Costs	281,188	284,523	98,093	1,203,591	1,281,219	805,663
Deicing Costs - Type I & IV	36,537	20,896	4,945	588,668	561,565	363,191
Catering, Oil & Other	417	25	238	1,667	885	238
Total Cost of Sales	318,141	305,443	103,275	1,793,925	1,843,669	1,169,092
Net Operating	339,974	337,051	165,889	1,528,493	1,790,194	1,400,589
OPERATING EXPENSES						
Personal Services						
Salaries	103,173	96,629	96,481	438,484	412,194	411,684
Overtime	13,900	18,626	246	56,609	81,428	48,664
Total Personal Services	117,073	115,254	96,727	495,093	493,622	460,348
Employee Benefits	42,512	55,795	32,662	181,260	188,950	142,223
Utilities & Communications	9,157	11,889	6,014	44,841	43,131	33,955
Purchased Services	54,535	32,854	23,931	225,634	237,070	269,721
Materials & Supplies						
Buildings	8,919	10,226	4,709	28,773	23,770	16,562
Grounds	1,883	3,329	7,096	7,533	10,280	9,026
Vehicles	26,033	12,986	8,808	114,815	108,573	73,958
Total Materials & Supplies	36,835	26,541	20,613	151,121	142,622	99,546
Administrative Expenses	15,730	14,360	5,577	73,286	65,865	57,972
Non-Capital Equipment	0	0	0	0	0	0
TOTAL EXPENSES	275,843	256,694	185,524	1,171,235	1,171,261	1,063,764
FBO Net Operating Results	\$ 64,132	\$ 80,357	\$ (19,635)	\$ 357,258	\$ 618,934	\$ 336,825

Notes to Financial Statements

1. Accounting Basis

This financial information is presented for the purposes of comparing budget to actual results and for indicating generally how revenues and expenses have compared to budgeted revenues and expenses through on a monthly basis. The financial information presented herewith is prepared on the Albany County Airport Authority's budgetary basis of accounting.

This report includes preliminary operating and performance statistics, and financial forecasts based upon the budgetary basis of accounting estimates that involve uncertainties that could result in actual financial results differing materially from preliminary estimates.

2. Cash Reserves

2020 Operating Budget	\$38,819,754
2020 Debt Service	10,950,553
2020 Debt Service Paid by PFCs	<u>(4,140,917)</u>
	\$45,629,390

Monthly Cash Outflow	(\$45,629,390/12)
	\$3,802,449

Months Operating Reserves	
\$27,261,979/3,802,449	~ 7.1 months

3. Accounts Receivable

The amount of accounts receivables represents approximately 10.91 days of average annual daily revenues calculated as follows:

$$\$45,728,390 / 365 = \$125,283$$

$$\$1,366,345 / \$125,283 = 10.91$$

Albany International Airport
For the four months ended April 30, 2020

	Current Month			Year to Date			12 Month Running	
	Budget	2019	2020	Budget	2019	2020	2019	2020
Enplanements	131,408	133,722	4,147	470,360	478,502	294,120	1,489,951	1,334,587
Operations								
<i>Passenger</i>	3,672	3,444	938	12,966	12,660	9,070	39,090	32,856
<i>Cargo</i>	344	304	248	1,395	1,304	1,020	4,082	3,466
<i>Charter, Corporate & Diversions</i>	262	250	63	1,018	1,014	635	3,418	3,366
<i>General Aviation</i>	775	955	754	3,353	3,333	3,642	12,942	14,172
<i>Military</i>	309	265	138	1,007	956	1,013	3,190	3,001
	5,362	5,218	2,141	19,739	19,267	15,380	62,722	56,861
Landed Weight (1,000 lbs)	147,698	147,433	42,819	534,907	534,079	420,954	1,642,398	1,554,671
Cargo/Mail & Express	1,510.8	1,530.0	1,551.1	5,861.9	6,113.0	5,575.0	18,718.5	20,546.9
Jet A Gallons	81,017	72,253	49,670	336,347	341,996	279,058	1,202,011	1,154,142
AvGas Gallons	5,121	4,431	3,128	15,756	15,038	14,956	54,075	65,911
Deicing Consortium	3,259	1,282	1,060	62,552	46,412	36,902	82,861	77,839
Deicing sprayed/retail	2,585	2,601	466	35,543	57,386	40,868	86,549	82,937
Parking Revenue	\$ 1,619,411	\$ 1,609,555	\$ 49,678	\$ 5,913,734	\$ 5,837,153	\$ 3,888,230	\$ 15,527,202	\$ 14,303,261
Revenue per enplanement		\$ 12.04	\$ 11.98		\$ 12.20	\$ 13.22	\$ 10.42	\$ 10.72
Transactions		59,471	2,926		210,925	135,076	637,611	566,798
Average transaction		\$ 27.06	\$ 16.98		\$ 27.67	\$ 28.79	\$ 24.35	\$ 25.24
Concession Sales								
Rental Cars		\$ 3,162,110	\$ 792,141		\$ 11,260,319	\$ 8,742,573	\$ 52,826,065	\$ 51,447,792
Revenue per enplanement		\$ 23.65	\$ 191.02		\$ 23.53	\$ 29.72	\$ 35.45	\$ 38.55
Food and Beverage		\$ 843,347	\$ 2,178		\$ 3,104,830	\$ 2,175,892	\$ 8,967,658	\$ 8,714,988
Revenue per enplanement		\$ 6.31	\$ 0.53		\$ 6.49	\$ 7.40	\$ 6.02	\$ 6.53
Retail		\$ 388,680	\$ 19,746		\$ 1,364,111	\$ 763,553	\$ 4,186,992	\$ 3,857,584
Revenue per enplanement		\$ 2.91	\$ 4.76		\$ 2.85	\$ 2.60	\$ 2.81	\$ 2.89

SCHEDULED AIRLINE PASSENGER SERVICE

Monthly Scheduled Flights are as follows:

	Airlines	Destination Airports	Non-Stop Destination Cities ⁽¹⁾	Non-Stop Scheduled Flights	Average Flights per Day	Mo. Seats Available	Mo. Landed Weight (lbs.)
Jan20	7	17	13	1,391	44.9	141,803	147,829,062
Feb20	7	16	12	1,374	47.4	141,833	147,219,632
Mar20	7	18	14	1,549	50.0	161,752	162,630,904
Apr20	7	17	13	891	30.0	103,200	102,522,032
May20	7	12	10	418	13.5	45,913	45,124,706
Jun20	7	15	12	556	18.5	65,955	65,335,083

⁽¹⁾ Four (4) cities may be served by two (2) airports; Chicago, Orlando, Tampa, and Washington DC.

Weekly schedule flight changes for the third week of May 2020 (#22) versus June 2020 (#26) and the third week of January 2020 (#3) versus June 2020 (#26) are as follows:

		Week				Year-To-Date (net)			
		#22	+	(-)	#26	#3	+	(-)	#26
ATL	Atlanta, GA	-	-	-	-	20	-	(20)	-
BWI	Baltimore, MD	14	12	-	26	26	-	-	26
MDW	Chicago-Midway	7	6	-	13	12	1	-	13
ORD	Chicago-O'Hare	19	-	(3)	16	40	-	(24)	16
CLT	Charlotte, NC	9	5	-	14	19	-	(5)	14
DEN	Denver, CO	7	-	-	7	-	7	-	7
DTW	Detroit, MI	14	-	-	14	25	-	(11)	14
FLL	Fort Lauderdale, FL	2	1	-	3	10	-	(7)	3
RSW	Fort Myers, FL	-	-	-	-	4	-	(4)	-
MYR	Myrtle Beach, SC	-	3	-	3	-	3	-	3
EWR	Newark, NJ	-	-	-	-	31	-	(31)	-
MCO	Orlando, FL	5	8	-	13	27	-	(14)	13
SFB	Orlando/Sanford, FL	2	-	-	2	2	-	-	2
PHL	Philadelphia, PA	10	-	-	10	30	-	(20)	10
PGD	Punta Gorda, FL	-	3	-	3	2	1	-	3
TPA	Tampa, FL	-	-	-	-	9	-	(9)	-
PIE	Tampa/St. Pete, FL	2	-	-	2	2	-	-	2
DCA	Washington DC-Reagan	-	7	-	7	33	-	(26)	7
IAD	Washington DC-Dulles	<u>7</u>	<u>-</u>	<u>-</u>	<u>7</u>	<u>21</u>	<u>-</u>	<u>(14)</u>	<u>7</u>
		98	45	(3)	140	313	12	(185)	140

Flight schedule changes for the third week of May 2020 (week #22) versus the third week of June 2020 (week #26) are as follows:

Airline Flight#	Destination	Departure Time	Daily Scheduled Flights	Type AC	# of Seats	AC Landed Weight	# Flights
-----------------	-------------	----------------	-------------------------	---------	------------	------------------	-----------

Third week of May 2020 (week #22 of 2020) weekly number of flights: 98

Additions

AA 557	Charlotte, NC	13:31	M T Th F Sa	A319	128	137,700	5
AA 5229	Wash. DC-Reagan	07:00	S M T W Th F Sa	CR7	65	67,000	7
JBlue 87	Fort Lauderdale, FL	16:00	M	A320	162	142,198	1
JBlue 119	Orlando, FL	16:01	F	A320	150	142,198	1
Algnt 491	Myrtle Beach, SC	17:20	Sa	A320	186	142,198	1
Algnt1129	Myrtle Beach, SC	19:20	M F	A320	186	142,198	2
Algnt1506	Punta Gorda, FL	18:24	S Th	A320	177	142,198	2
Algnt1564	Punta Gorda, FL	10:13	Sa	A320	177	142,198	1
SWest133	Baltimore, MD	11:45	S M Th F Sa	B737W	143	187,700	5
SWest506	Baltimore, MD	18:20	S M T W Th F Sa	B737H	175	146,300	7
SWest1580	Orlando, FL	09:00	S M T W Th F Sa	B737H	175	146,300	7
SWest1550	Chicago - MDW	07:00	<u>S M T W Th F</u>	B737W	143	187,700	<u>6</u>
			6 8 5 4 7 8 7				45

Deductions

UA 1544	Chicago-ORD	15:22	<u>S T Sa</u>	CR7	70	67,000	(3)
			1 - 1 - - - 1				(3)

Third week of June 2020 (week #26 of 2020) weekly number of scheduled flights: **140**

Monthly Report

April 2020



Monthly Enplanements

April 2020

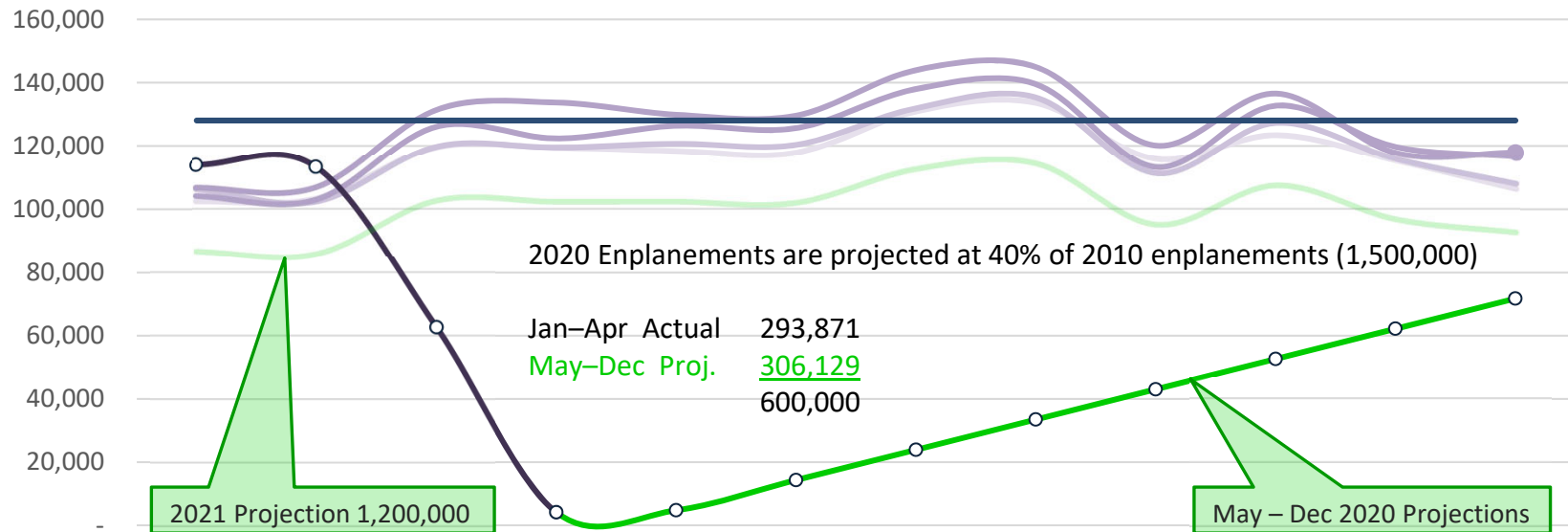

	JAN	FEB	MAR	APR	MAY	JUN	JUL	AUG	SEP	OCT	NOV	DEC
2016	102,325	103,214	119,403	119,362	118,293	117,743	130,930	133,612	115,752	123,374	115,220	106,206
2017	106,168	102,255	119,677	119,423	120,665	120,316	131,916	135,306	111,208	127,281	115,758	107,862
2018	104,011	102,852	126,052	122,342	126,345	125,618	137,983	139,520	113,139	132,723	119,639	116,482
2019	106,622	106,760	131,398	133,722	129,868	129,585	143,957	144,967	120,058	136,558	117,662	117,812
2020	113,870	113,232	62,622	4,147	4,784	14,350	23,917	33,483	43,050	52,616	62,183	71,746
Proj 2021	86,582	85,746	102,572	102,225	102,291	101,897	112,541	114,321	95,058	107,407	96,736	92,621
Budget	128,041	128,041	128,041	128,041	128,041	128,041	128,041	128,041	128,041	128,041	128,041	128,041

Enplanements - Twelve Month Running Total

April 2020

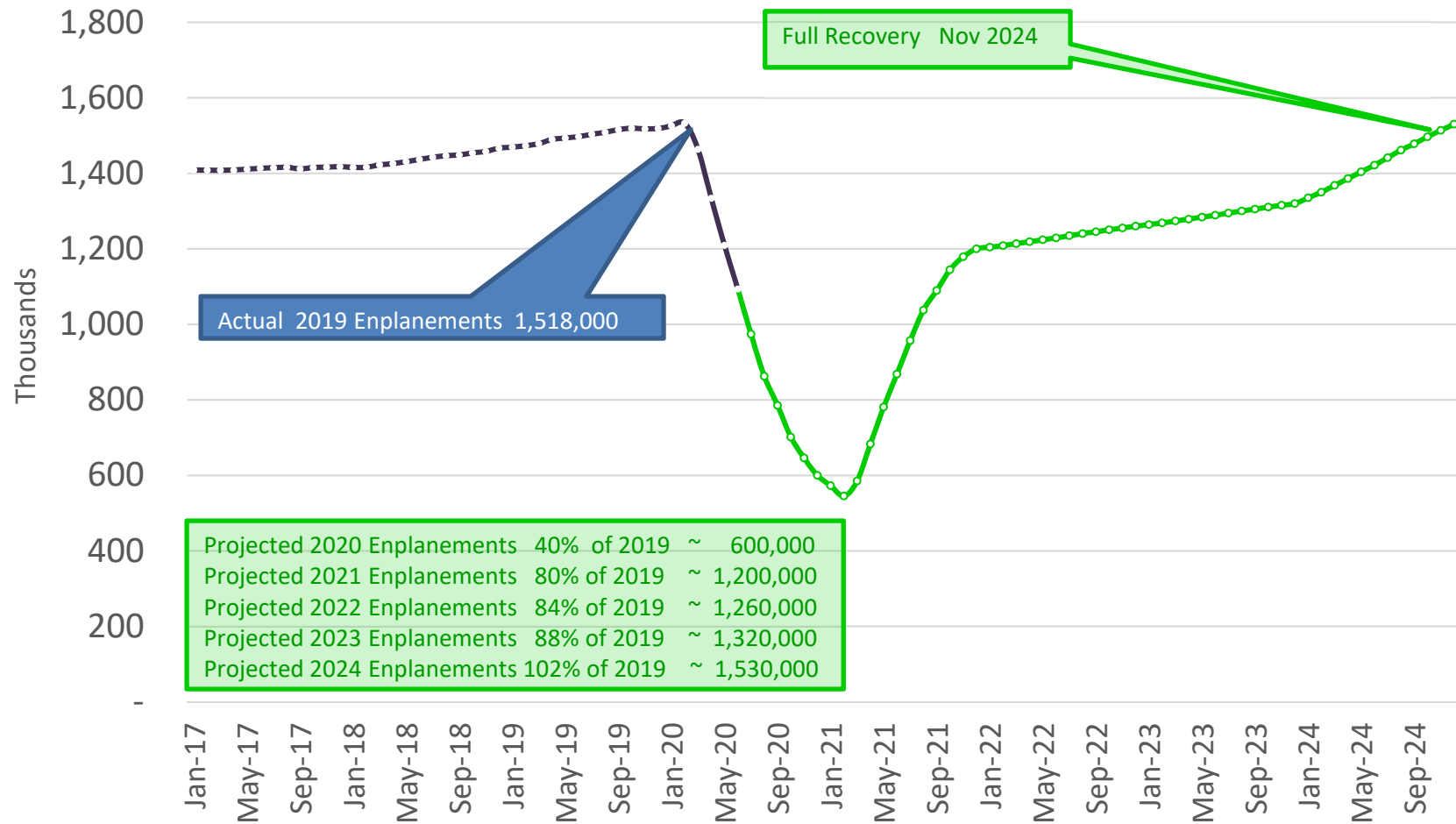

Enplanements – Running Weekly Throughput since March 7

April 2020



Running Seven (7) Day Throughput National vs. ALB

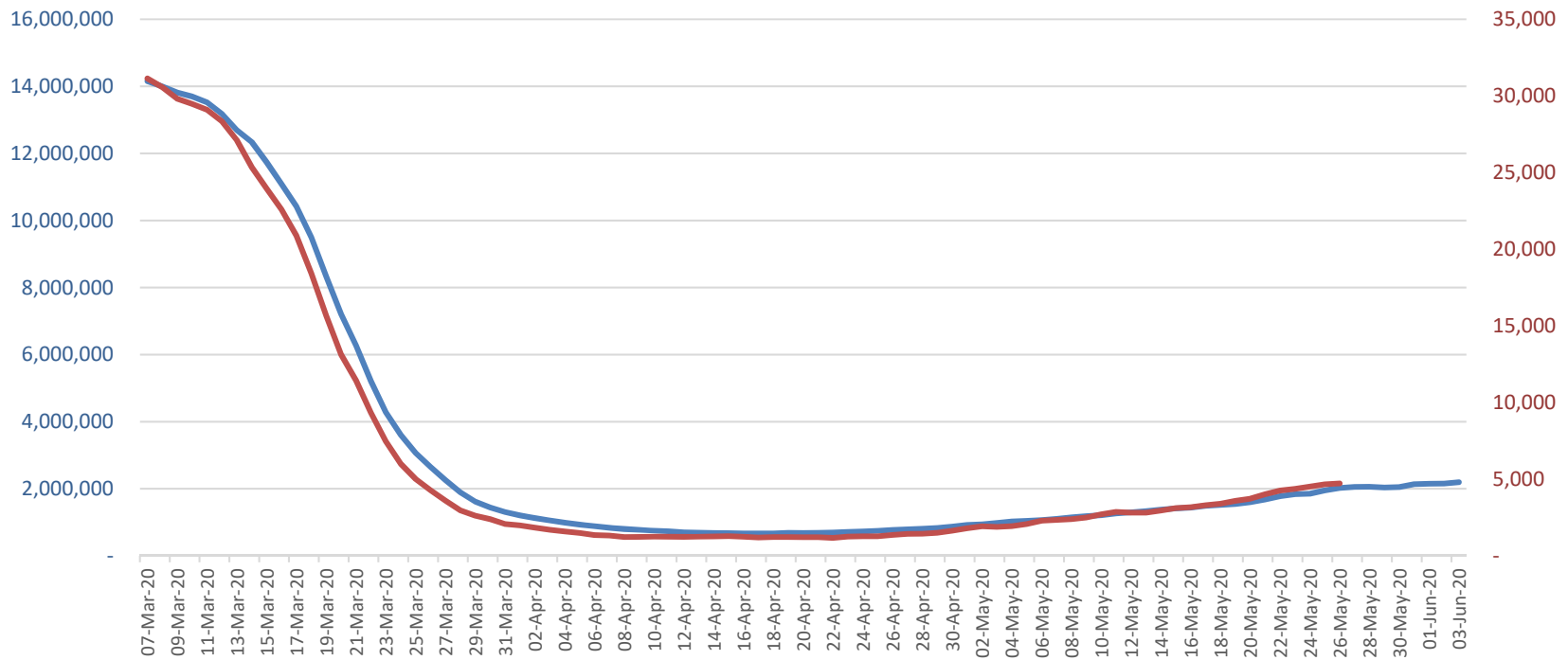

Operating Revenue vs Operating Expense (including FBO)

April 2020

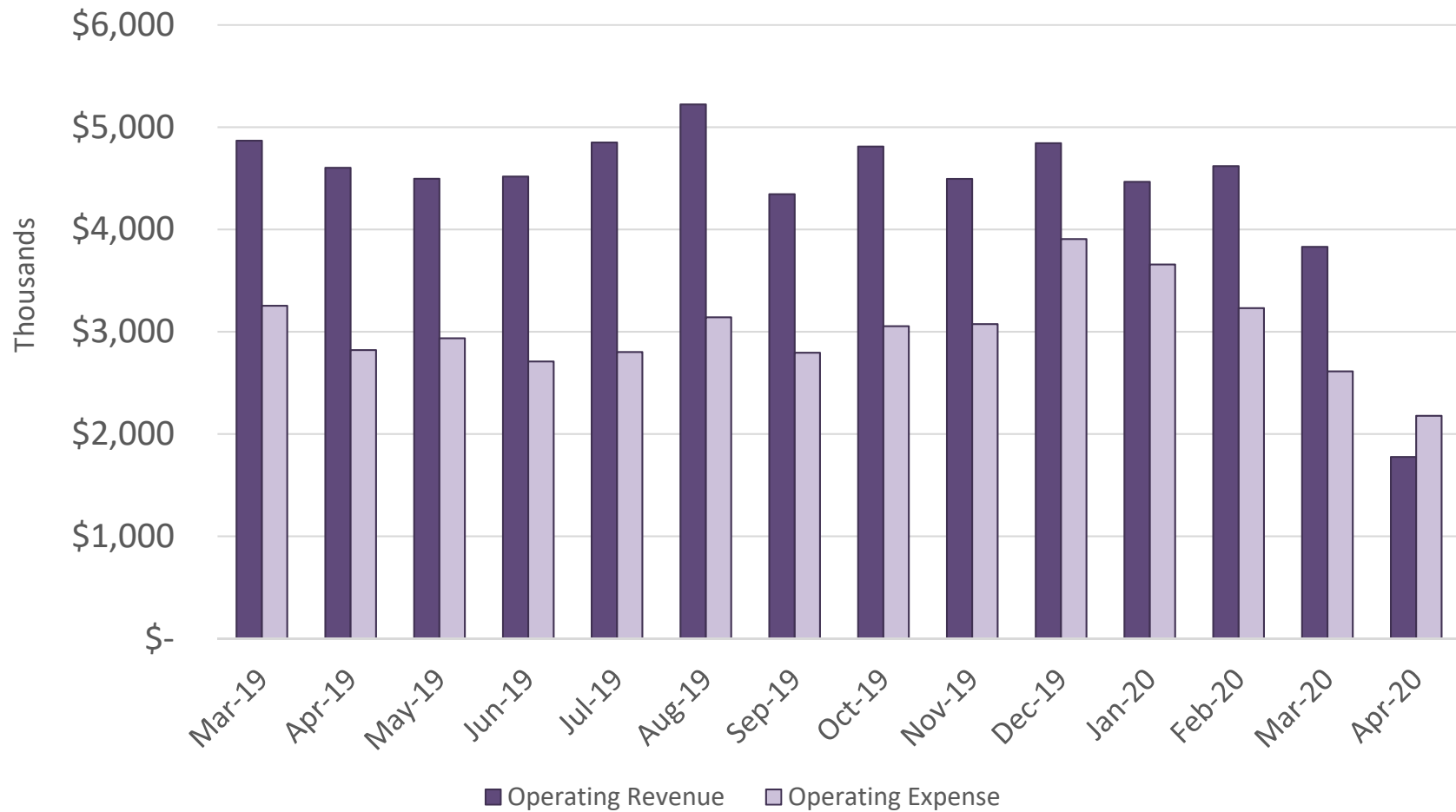

Operating Profit w FBO Operating Profit

April 2020

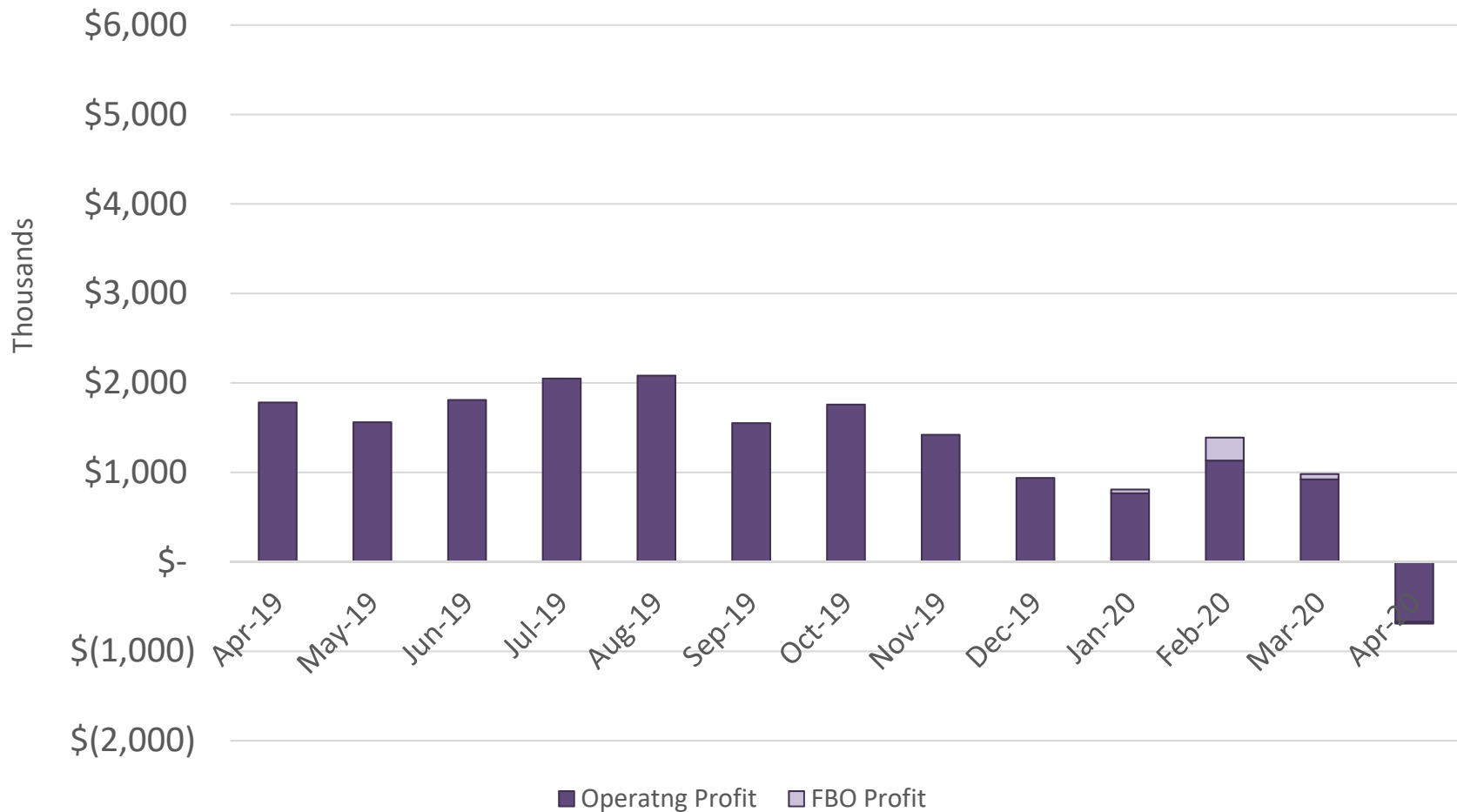

Operating Revenue

April 2020

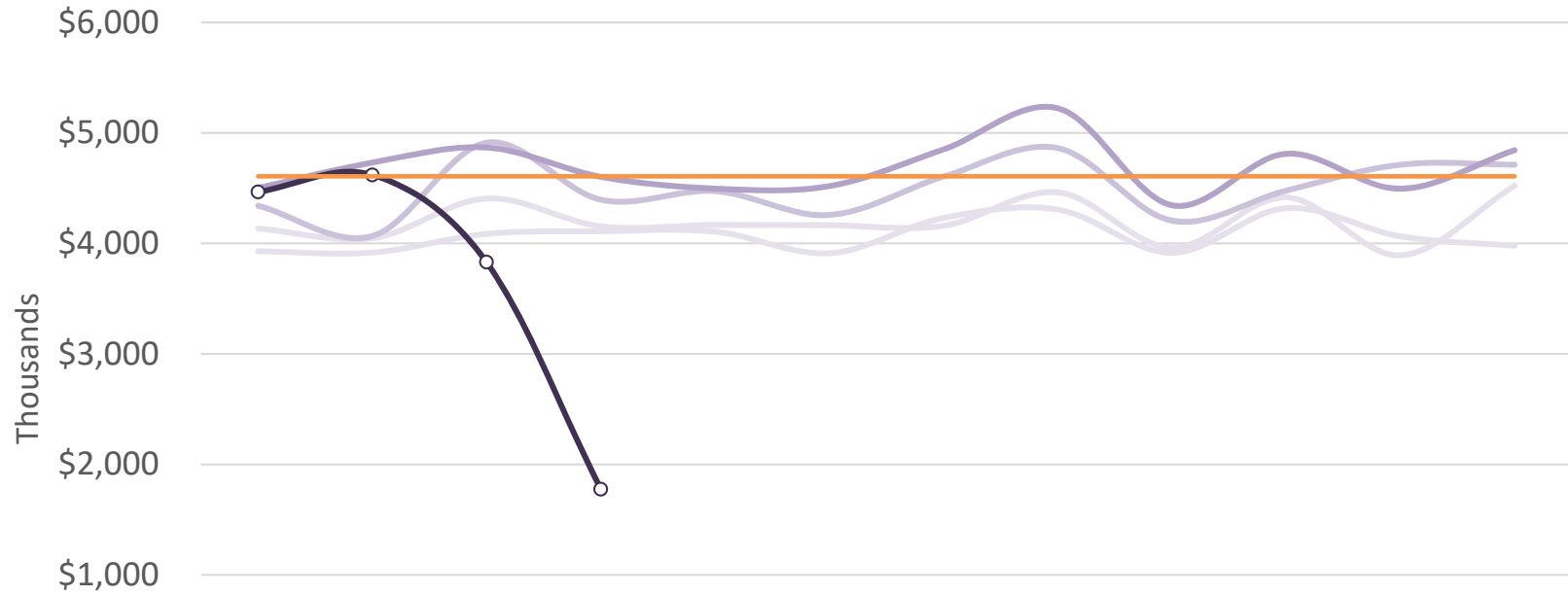

\$-	JAN	FEB	MAR	APR	MAY	JUN	JUL	AUG	SEP	OCT	NOV	DEC
2016	3,928,860	3,917,499	4,087,012	4,109,382	4,106,818	3,910,886	4,231,228	4,307,318	3,914,972	4,319,343	4,064,148	3,978,554
2017	4,135,262	4,046,736	4,407,251	4,154,501	4,167,155	4,164,833	4,159,376	4,462,139	3,960,352	4,418,382	3,892,433	4,521,852
2018	4,341,336	4,067,370	4,912,273	4,395,345	4,473,235	4,256,906	4,604,285	4,863,261	4,206,101	4,477,987	4,712,918	4,712,918
2019	4,502,220	4,732,146	4,868,289	4,603,032	4,496,366	4,518,483	4,850,750	5,223,544	4,345,347	4,811,613	4,494,835	4,843,995
2020	4,465,887	4,619,737	3,830,483	1,775,425								
Budget	4,607,697	4,607,697	4,607,697	4,607,697	4,607,697	4,607,697	4,607,697	4,607,697	4,607,697	4,607,697	4,607,697	4,607,697

Operating Revenue

April 2020

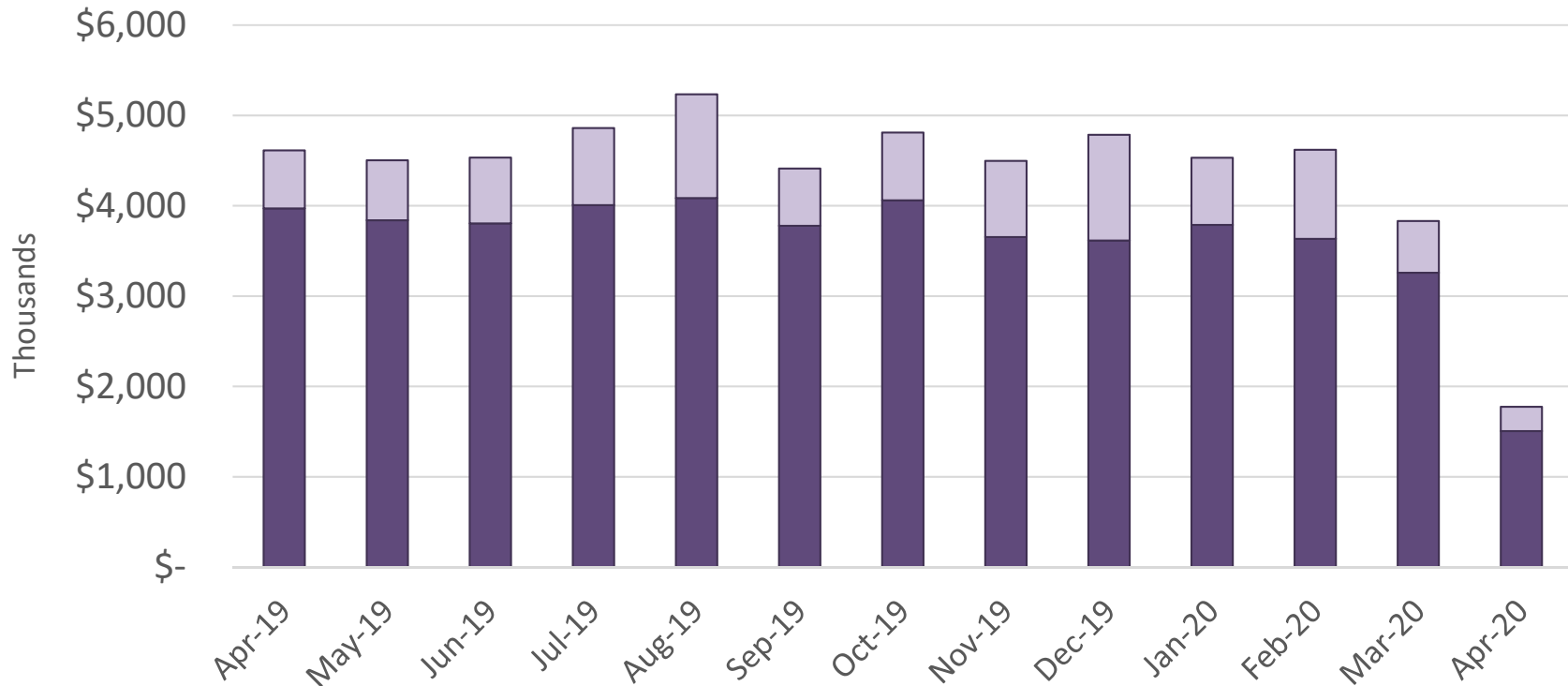

	Apr-19	May-19	Jun-19	Jul-19	Aug-19	Sep-19	Oct-19	Nov-19	Dec-19	Jan-20	Feb-20	Mar-20	Apr-20
■ FBO	642,494	664,296	729,805	852,230	1,148,274	634,829	751,308	841,822	1,170,465	742,496	986,533	571,488	269,164
■ Airport	3,971,151	3,839,041	3,804,268	4,007,541	4,085,761	3,777,875	4,059,831	3,654,429	3,615,318	3,788,835	3,633,204	3,258,995	1,506,251

■ Airport ■ FBO

Operating Expense

Apr 2020

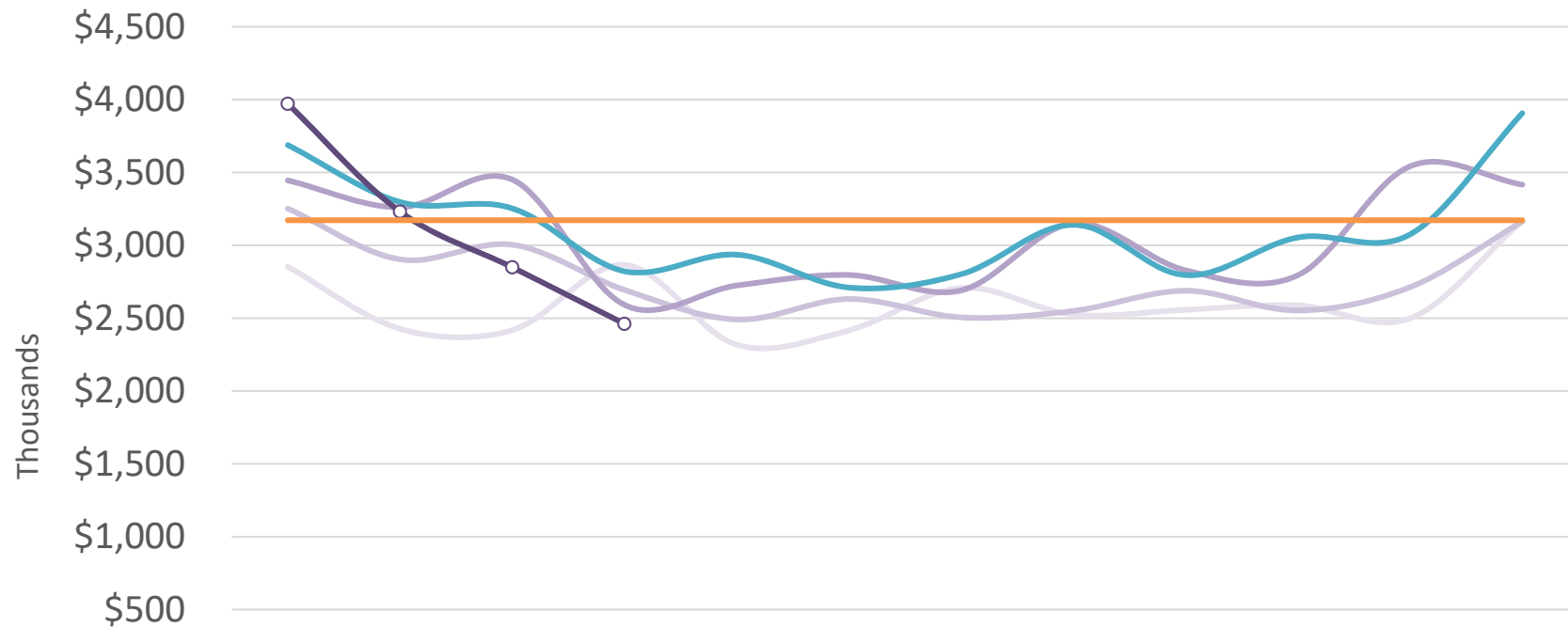

\$-	JAN	FEB	MAR	APR	MAY	JUN	JUL	AUG	SEP	OCT	NOV	DEC
2016	2,852,717	2,427,095	2,418,031	2,866,213	2,318,096	2,417,098	2,708,221	2,524,316	2,557,925	2,587,711	2,499,105	3,168,810
2017	3,251,894	2,903,201	3,004,037	2,694,039	2,491,006	2,631,640	2,505,195	2,550,098	2,688,234	2,552,571	2,712,782	3,163,109
2018	3,445,227	3,260,564	3,451,165	2,590,563	2,724,077	2,796,448	2,690,407	3,150,598	2,828,280	2,794,640	3,542,749	3,416,310
2019	3,687,922	3,297,104	3,254,095	2,821,328	2,935,808	2,710,040	2,801,912	3,141,724	2,794,858	3,054,094	3,074,811	3,906,218
2020	3,970,707	3,230,788	2,849,086	2,461,173								
Budget	3,172,139	3,172,139	3,172,139	3,172,139	3,172,139	3,172,139	3,172,139	3,172,139	3,172,139	3,172,139	3,172,139	3,172,139

Operating Expense

April 2020

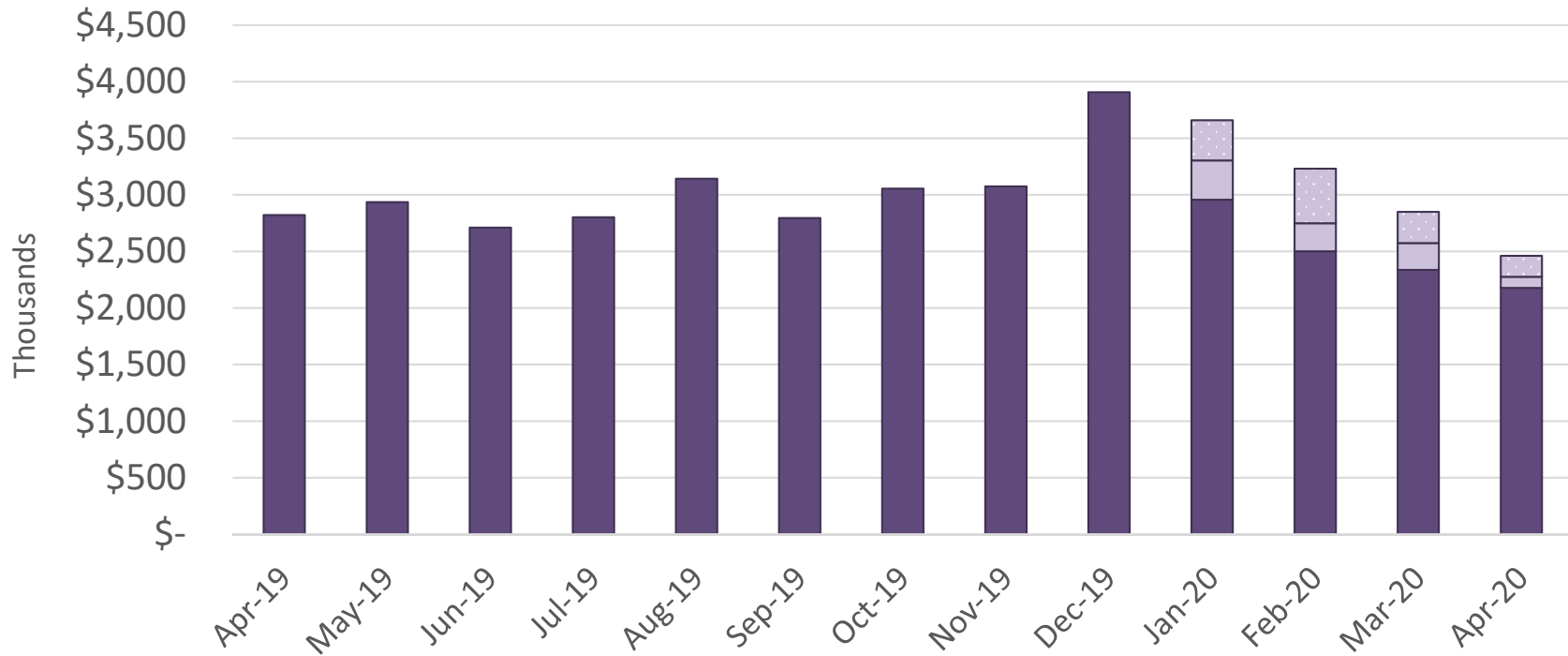

	Apr-19	May-19	Jun-19	Jul-19	Aug-19	Sep-19	Oct-19	Nov-19	Dec-19	Jan-20	Feb-20	Mar-20	Apr-20
FBO - Admin	-	-	-	-	-	-	-	-	-	354,206	481,772	275,733	185,524
FBO - COGS	-	-	-	-	-	-	-	-	-	347,579	248,301	236,466	98,093
Airport	2,821,328	2,935,808	2,710,040	2,801,912	3,141,724	2,794,858	3,054,094	3,074,811	3,906,218	2,956,612	2,500,715	2,336,887	2,177,556

■ Airport
 ■ FBO - COGS
 ■ FBO - Admin

Unrestricted and Restricted Funds

As of April 2019 & 2020



	2019	2020
Operating	\$28,890,485	\$27,261,971
Capital	39,132,746	30,860,719
Reserves – Debt Service	16,705,893	56,599,747
	\$84,729,124	\$111,722,437

2020 Reserves – Debt Service includes Bond Series 2010 held in escrow.

Cash and Cash Equivalents - Operating

April 2020

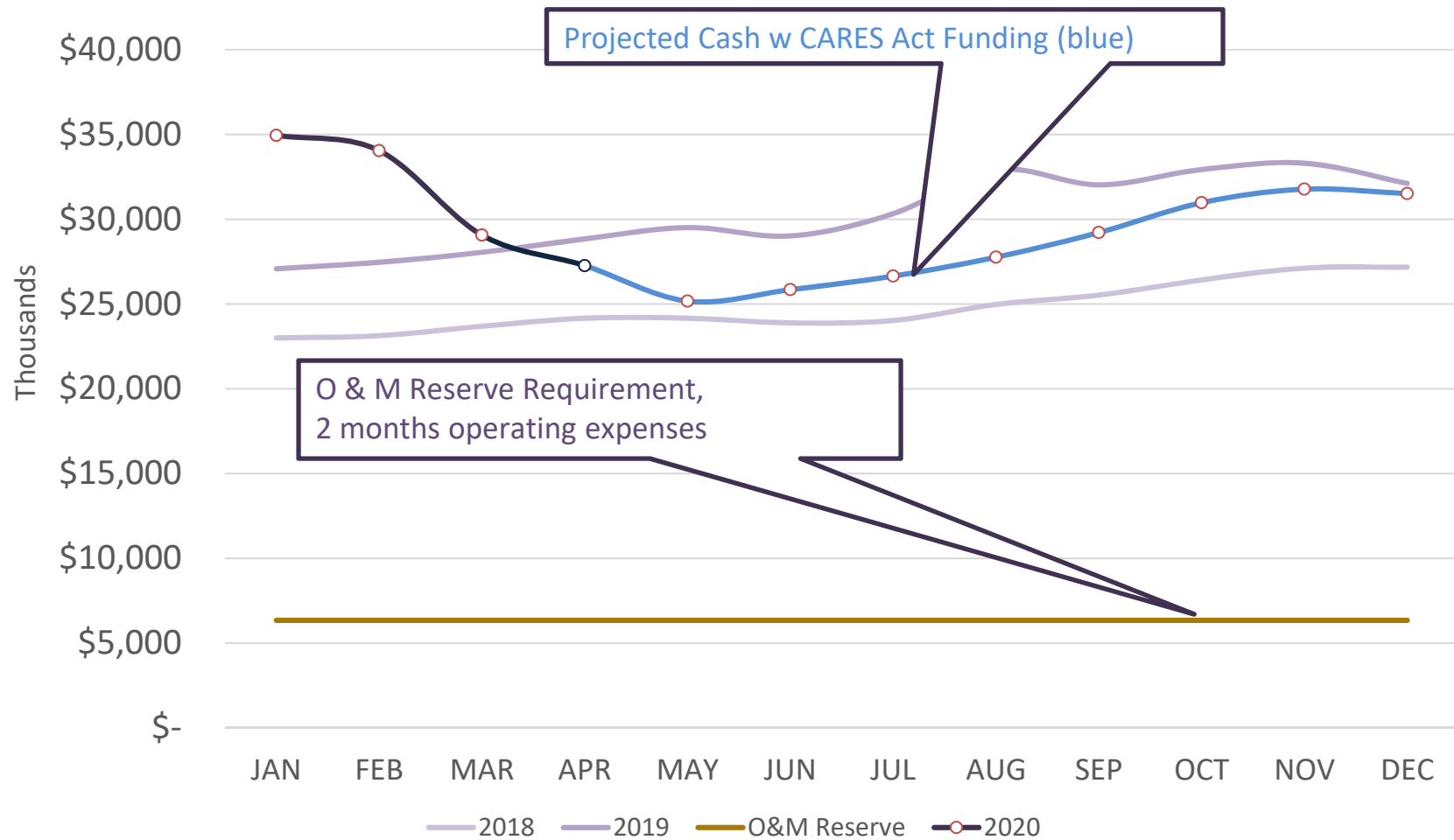

Cash and Cash Equivalents - Capital

April 2020

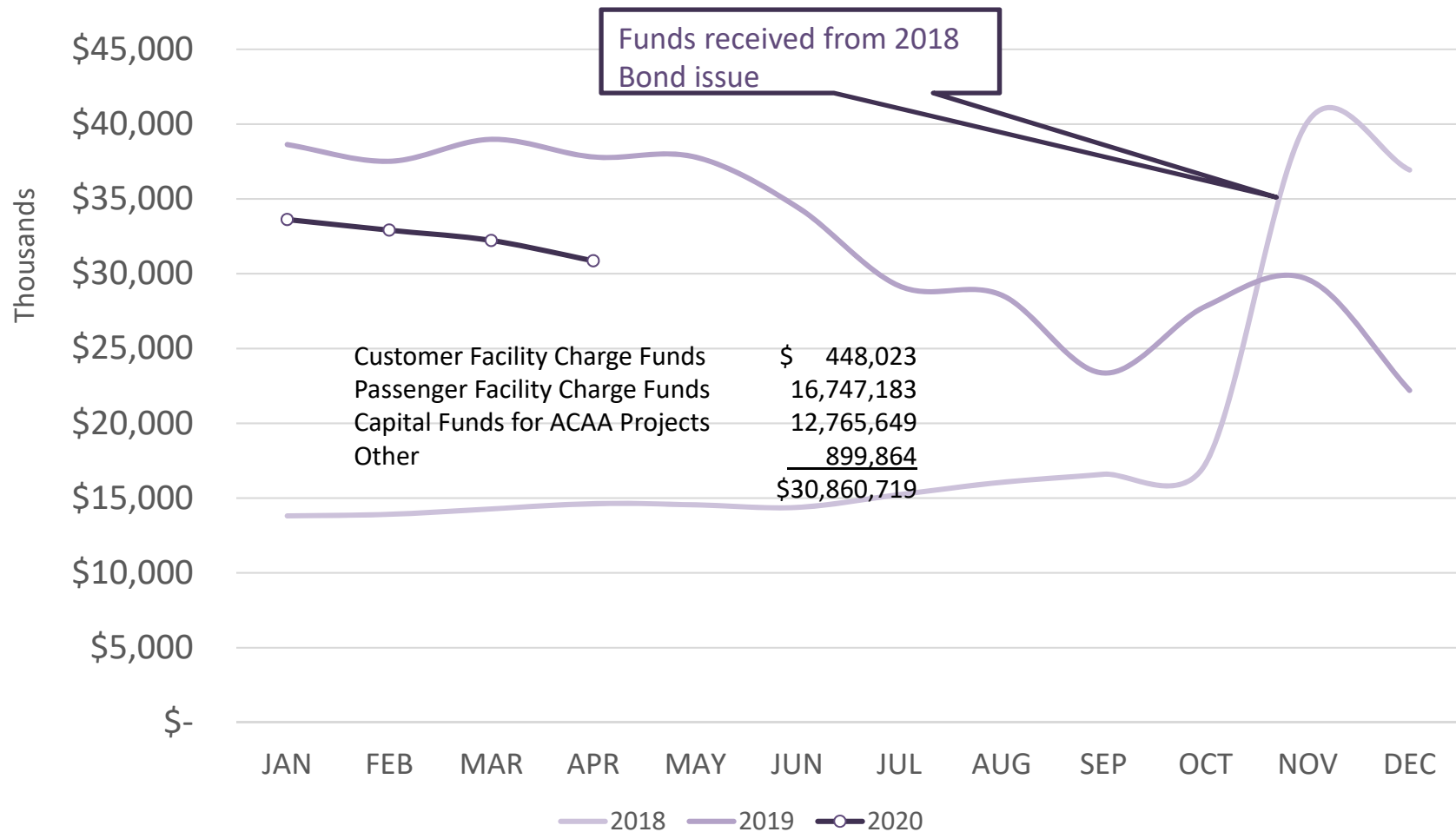

Cash and Cash Equivalents— Reserves & Debt Service

April 2020

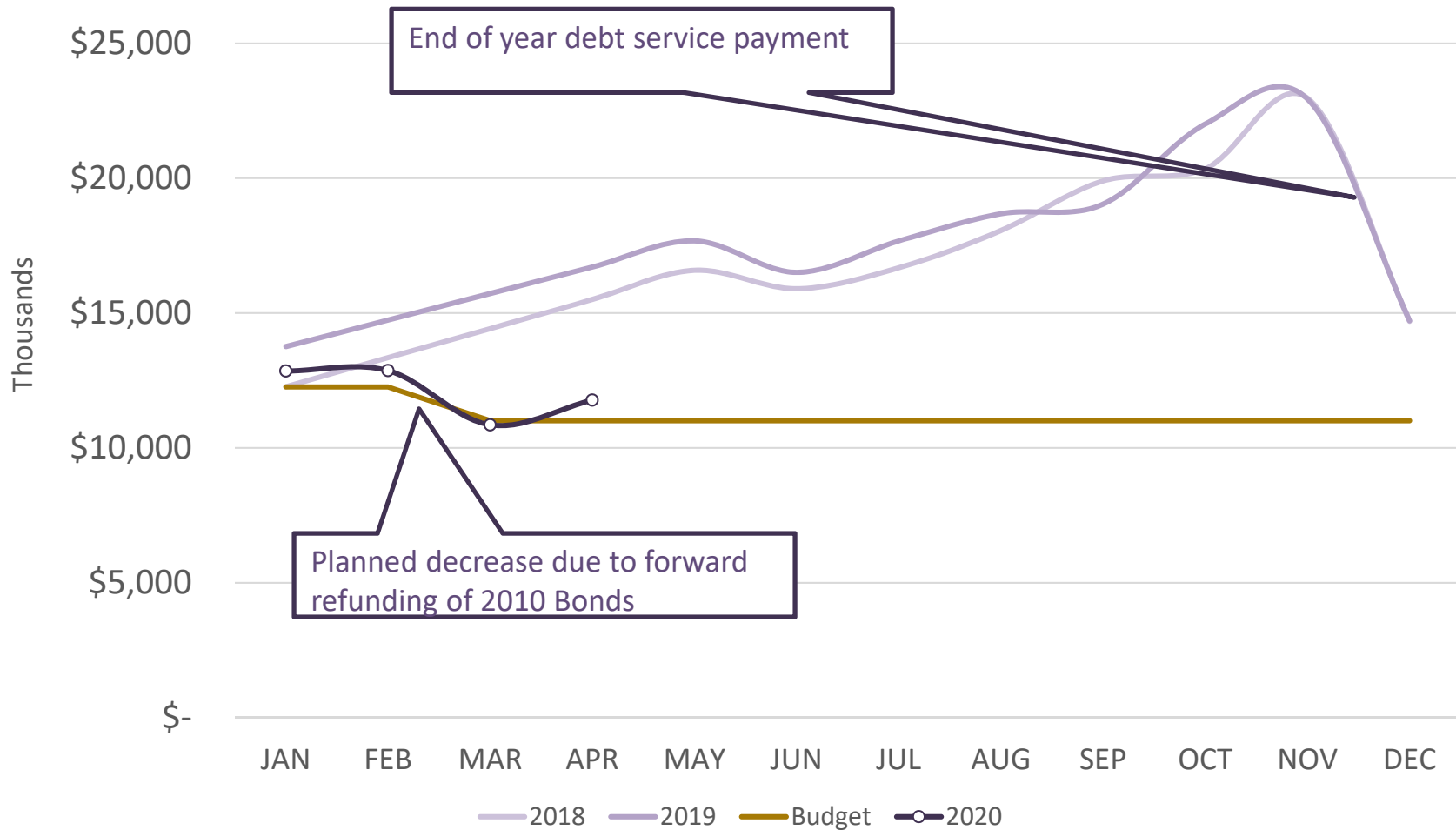



Capital Projects (including \$11.0M of Debt Service)

April 2020 (as of May 30)

	Mar 2020	Apr 2020	May 2020
Capital Project Sources			
FAA	\$14,773,654	\$14,058,521	\$11,158,840
NYS DOT	4,867,565	3,449,159	1,897,497
PFCs	12,390,298	12,390,298	12,135,298
Bond Funds Remaining (2018B & 2019A)	2,554,399	953,568	985,174
ACAA Capital Cash on Hand	751,506	4,067,805	410,472
ACAA Receivables, NYSDOT, Airlines	5,520,398	2,557,640	2,134,835
ACAA Future Operating Cash (Debt Ser.)	<u>6,908,636</u>	<u>6,908,636</u>	<u>6,908,636</u>
	\$47,766,456	\$44,385,627	\$35,630,752
Capital Project Uses			
Project Costs 26 Current Projects	\$94,272,148	\$95,505,362	91,156,775
Cost To Date	<u>(58,569,512)</u>	<u>(61,889,941)</u>	<u>(66,417,702)</u>
	35,702,636	33,615,421	24,739,073
Debt Service	<u>11,049,553</u>	<u>11,049,553</u>	<u>11,049,553</u>
Commitment Balance	\$46,752,189	\$44,664,974	\$35,788,626

Monthly Scheduled Passenger Airline Service

April 2020



	Airlines	Non-Stop Destination Airports	Non-Stop Destination Cities	Non-Stop Scheduled Flights	Average Flights per Day	Monthly Seats Available	Monthly Landed Weight
Jan20	7	17	13	1,391	44.9	141,803	147,829K
Feb20	7	16	12	1,374	47.4	141,833	147,219K
Mar20	7	18	14	1,549	50.0	161,752	162,630K
Apr20	7	17	13	891	30.0	103,200	102,522K
May20	7	12	10	418	13.5	49,913	45,124K
Jun20	7	15	12	556	18.5	65,955	65,335K

Monthly Report



THANK YOU

AGENDA ITEM NO. 6

Project Development



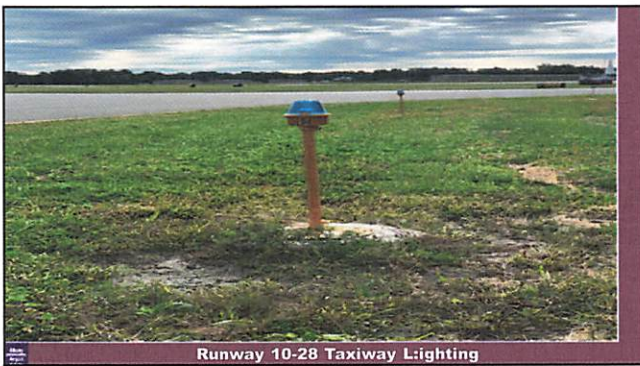







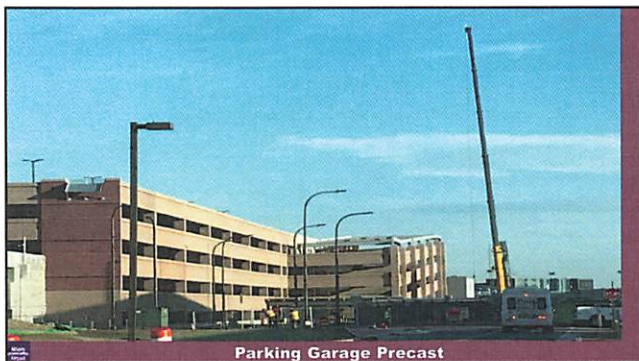



Terminal Amenities



Long Term Parking Lot Paving



Air Traffic Control Tower

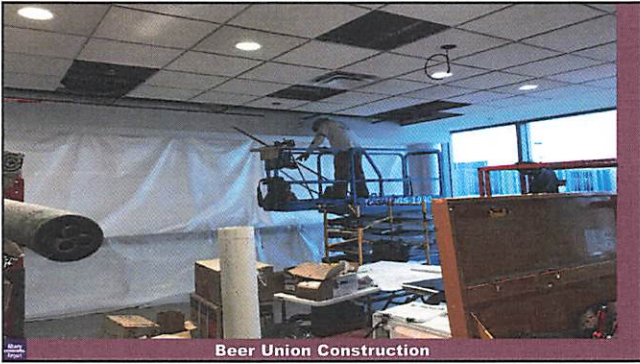





ALBANY COUNTY AIRPORT AUTHORITY
ALBANY INTERNATIONAL AIRPORT
ADMINISTRATION BUILDING
SUITE 200
ALBANY, NEW YORK 12211-1057

TEL: 518-242-2222
ADMIN FAX: 518-242-2641
FINANCE FAX: 518-242-2640
SITE: www.albanyairport.com

PROJECT STATUS REPORT

June 8, 2020

I. AIRSIDE IMPROVEMENTS

A) Runway 10-28 and Taxiway C Edge Light Replacement (Contract No. 946-E)

DLC Electric remobilized and is continuing the installation of the new Runway 10-28 and Taxiway C edge lights. The project includes directional drilling under several taxiways, installation of new wind cones along with the new LED edge lights and wiring. Due to the current COVID-19 situation, the contractor has been able to work longer hours and work days instead of nights, speeding up the project schedule. The new edge lights and wind cones have been installed. The contractor is pulling new wires to connect and energize the new system.

B) Airport Drainage Culvert Replacement (Contract No. 930-GC)

Rifenburg Contracting has remobilized and completed the pipe crossing under old Niskayuna Road and restored the road for use last week. The airfield grading and pipe installation work at the end of Runway 1 was completed in less than 2 weeks. The contractor made repairs to damaged glycol trenches that were discovered when they were cleaned. The contractor is demobilizing and cleaning up the work areas.

C) Replacement of Boarding Bridges A3, A5, B10 & C1 (Contract No. S-1039)

C & S Engineering completed the design and the project was advertised and sent out for bid. The low bids for both 1039-GC and 1039-E are action items for this Board meeting.

II. LANDSIDE IMPROVEMENTS

A) Revenue Upgrades and PARCS System (Contract #990-GC)

The existing parking revenue system has been replaced with the PARCS system. Amano McGann is working with ATI Access Control to monitor and upgrade the new PARCS system that includes LPR's (License Plate Readers) and EZ Pass Plus antennas,

which are all in place and active. The Long Term, Short Term and North Garage entrances and exits are operating with the new equipment. The new equipment has been installed in the new garage. Testing of the new equipment is in progress but has been put on hold until the new garage is opened.

B) New Parking Garage (Contract No. S-989, GCR, DEM, PC, SF, EL)

The project was divided into 4 separate contracts to expedite the construction. The Precast Concrete Contract 989-PC, which is the fabrication and erection of the precast garage, includes caulking the joints and sealing the top of the double T's. This has been completed. The contractor was onsite last week cleaning the brick veneer. Contract 989-SF, which is the site and utility relocations, pile driving and concrete pile caps that LeChase Construction is working on project closeout. This is still ongoing. Contract 989-EL is for the elevators (3 units) two for the Garage and one for the Pedestrian Bridge. This was awarded to Kone, Inc. Kone has installed and tested the two elevators in the new parking garage and one in the new pedestrian bridge. All equipment has been approved for use. LeChase Construction is the contractor for 989-GCR, which includes the pedestrian bridge to the Terminal, the vehicle bridge to the garage, electrical, communication and plumbing work inside the new precast structure. The contractor has completed the work on the new pedestrian bridge that connects the new garage to the Terminal. The contractor has received a Temporary Certificate of Occupancy and is currently working on punch list items.

C) Terminal Amenities (Contract No. S-991, GC, P, R, W, ES)

This project was divided into 5 separate contracts. Contract 991-GC is for the new Terminal flooring (terrazzo tile and carpet), soffit lighting, new ceiling in Times Square and various wall finishes was awarded to VMJR Companies. VMJR has completed the terrazzo and tile work, as well as wall finishes. The crew continues to work on punch list items. Contract 991-P is for the bathrooms rehab and upgrades, the Pet Relief area, the ceiling and lighting in the baggage carousel area, HVAC upgrade at the ticket counters and door refinishing and replacements. This contract was awarded to VMJR Companies and work has been completed for this contract. Turner Construction and VMJR are working to close out this project. Contract 991-R is for the removal of the existing skylight in A Concourse and replacement with a metal roof and photovoltaic panels mounted on top. This was awarded to Kasselmann Electric. Kasselmann is working with Turner Construction to close out this project. Contract 991-ES is for the replacement of the escalators in the existing parking garage and was awarded to Wainschaf Associates. Wainschaf has completed the installation of the new escalators and is in the process of closing out the contract. Contract 991-W is for all new Wayfinding signs throughout the Terminal and the new parking garage to guide people to all the Terminal amenities. The Color Ad crew completed the sign installation in the new garage this week and is working on their punch list items and contract closeout.

The Gateway Sign foundations are in and the precast columns are in place. The structural steel and signage including wiring is complete and the sign is stored onsite and is ready to be erected when the COVID-19 pandemic is over.

D) Long Term and Employee Parking Lot Paving (Contract 1009-PAV)

Due to the COVID-19 virus, passenger parking is greatly reduced which allowed for a unique opportunity to empty two parking lots completely and let a contractor mill and pave them. The project is an action item on today's Board meeting.

E) Air Traffic Control Tower (Contract 1013-SW, M & E)

The FAA has requested some upgrades to their facility. Sage Engineering put together bid packages for Sitework (SW), HVAC (M) and Electrical (E) which were bid the end of September and approved by the Board in October. J.H.Maloy Construction has completed all the sitework except landscaping which will be completed when FAA restrictions are lifted. Eckert Mechanical and Stilsing Electric have completed the installation of the new equipment and are in working with ACAA and the FAA to complete the punch list. Sage Engineering is completing the design for the roof and elevator replacements to be bid later this year. The FAA is restricting access to their facility due to COVID-19.

F) New Terminal Concessions

The Hudson Valley Wine Bar was closed on January 2, 2020. Construction work was progressing but has been halted due to COVID-19. The vendor, HMS Host, has taken delivery of the new equipment, which will be installed when work resumes. The space is being converted to the Beer Union, which is going to feature craft beers. It will be advertised as part of the Taste New York campaign.

AGENDA ITEM NO. 7

Counsel

AGENDA ITEM NO. 8

Concessions/Ambassador Program



ALBANY COUNTY AIRPORT AUTHORITY
 ALBANY INTERNATIONAL AIRPORT
 ADMINISTRATION BUILDING
 SUITE 200
 ALBANY, NEW YORK 12211-1057

TEL: 518-242-2222
 ADMIN FAX: 518-242-2641
 FINANCE FAX: 518-242-2640
 SITE: www.albanyairport.com

June 8, 2020

Marketing, Concessions & Ambassador Program

Minority Percentages in the Concession's Workforce

Date	HMS Host	OHM	Paradies	Dunkin Donuts
May 2019	18/67=26.8%	28/43=65%	15/22=68%	5/9=55%
June 2019	20/64=31.2%	24/41=58.5%	15/24=62.5%	6/10=60%
July 2019	20/64=31.2%	23/40=57.5%	15/24=62.5%	7/12=58.3%
Aug 2019	20/58=34.5%	27/33=81.8%	13/22=59%	6/10=60%
Sept 2019	21/55=38.2%	25/32=78%	12/20=65%	6/9=66.6%
Oct 2019	23/61=37.7%	37/48=77%	16/24=66%	7/10=70%
Nov 2019	29/61=47.5%	37/45=82%	15/22=68%	8/12=66.6%
Dec 2019	27/69=39%	64/75=85.3%	15/22=68%	5/11=45.45%
Jan 2020	26/67=38.8%	60/70=86%	15/22=68%	5/11=45.45%
Feb 2020	26/60=43.3%	50/63=79.3%	13/25= 52%	5/11=45.45%
Mar 2020	0/4=0%	2/4=50%	2/10=20%	3/5=60%
April 2020	0/1	0	1/8=12.5%	3/5=60%
May 2020	0/1	0	2/9 = 22%	4/6=66.6%

159 employees/now 16

Concessions

Adirondack Lodge – closed
 Silks of Saratoga – closed/plans for remodeling on hold.
 Starbucks – closed
 The Local – closed
 Burger King - closed
 Hudson Valley Beer Union – closed under remodel

Empire Deli – closed
 Wolfgang Puck Pizza - closed
 Chick fil A – closed

Dunkin Donuts – Open, hours of operation – 4:00 am – 8:00 pm
 Plans for remodeling are on hold.

Gift/News on A – closed
 Gift News on B – limited hours
 Gift/News on C - open

AGENDA ITEM NO. 9

Public Affairs



ALBANY COUNTY AIRPORT AUTHORITY
ALBANY INTERNATIONAL AIRPORT
ADMINISTRATION BUILDING
SUITE 200
ALBANY, NEW YORK 12211-1057

TEL: 518-242-2222
ADMIN FAX: 518-242-2641
FINANCE FAX: 518-242-2640
SITE: www.flyalbany.com

Public Affairs Report June 2020

EVENTS

The Airport Authority closed the third floor Observation Level following the onset of the Coronavirus. This resulted in the cancellation of events planned for the Observation Level including an AOPA Safety Seminar. Both the Patriot Flight and Leatherstocking Honor Flight cancelled their spring veterans' flights to Washington. Pre-flight welcoming ceremonies for the veterans are normally held in the baggage claim area at 6:00 a.m.



REAL ID NEWS CONFERENCE

A planned summer news conference to alert travelers of the need of a REAL ID by October 1, 2020 was cancelled. Due to the Coronavirus, the federal government has extended the REAL ID requirement until October 1, 2021.

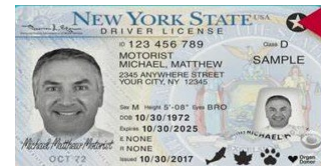

GLOBAL ENTRY

Customs and Border Patrol had planned to conduct a Global Entry registration program in March. The event was postponed due to the Coronavirus. No new date has been set for the event.

MEDIA

Media is being kept up-to-date on Airport actions during the pandemic via news releases, advisories and phone interviews.

AGENDA ITEM NO. 10

**Authorization of Contracts/Leases/Contract
Negotiations/Contract Amendments**

AGENDA ITEM NO. 10.1

**Authorization to Award Construction
Contract 1039-GC Passenger Boarding
Bridge Improvements to AERO
Bridgeworks, Inc.**

AGENDA ITEM NO: 10.1
MEETING DATE: June 8, 2020

ALBANY COUNTY AIRPORT AUTHORITY
REQUEST FOR AUTHORIZATION

ACAA Approved
06/08/2020
Contingent on FAA
concurrence and
compliance with
Apprenticeship Program

DEPARTMENT: *Planning and Engineering*
Contact Person: *John LaClair, P.E., Chief Engineer*

PURPOSE OF REQUEST:

Construction Contract: *Authorization to Award Construction Contract 1039-GC
Passenger Boarding Bridge Improvements to AERO
Bridgeworks, Inc.*

CONTRACT AMOUNT:

Base Amount: \$2,520,000.00

BUDGET INFORMATION:

Federal Airport Improvement Program
Anticipated in Current ALB Capital Plan: Yes ✓ No ___ NA
Funding Account No.: CPN 2251

AWARD CONDITIONS MET:

Apprenticeship Pending DBE Y MWBE N/A

Service Disable Veteran Owned Business (SDVOB) N/A

FISCAL IMPACT - FUNDING (Dollars or Percentages)

Federal 90% CARES Act 10%
Term of Funding: 2020-2021
Grant No.: 3-36-0001-142-2020 STATE PIN: pending

JUSTIFICATION:

Request to award Contract 1039-GC for Passenger Boarding Bridge Improvements on Gates A3, A5, B10 & C1 programmed under the Federal FFY 2020 Airport Improvement Program passenger entitlement program, to qualified low bidder AERO Bridgeworks, Inc. of Marietta, GA for \$2,520,000.00 Base Bid. The contract scope includes replacement of an existing passenger boarding bridges A-3, A-5, B-10 & C-1 and the removal of the Over-the-Wing bridges at gates C-2 & C-3. The existing passenger boarding bridges are over 20 years old and the maintenance costs to keep them operational increases annually. New bridge installation will include removal of the existing unit and installation of a newly fabricated unit at each location. Award contingent upon FAA concurrence and compliance with Apprenticeship Program.

AGENDA ITEM NO: 10.1
MEETING DATE: June 8, 2020

CHIEF EXECUTIVE OFFICER'S RECOMMENDATION:

Recommend approval.

FINAL AGREEMENT SUBJECT TO APPROVAL BY COUNSEL: YES ✓ NA _____

PROCUREMENT DEPARTMENT APPROVAL:

Procurement complies with Authority Procurement Guidelines and Chief Financial Officer has approved. YES ✓ NA _____

BACK-UP MATERIAL:

Please refer to the attached Contract 1039-GC Bid Table, Bid Offering and C & S Engineer's Letter of Recommendation for Award.

CONTRACT #1039-GC
Replacement of Passenger Boarding Bridges A3, A5, B10 & C1 - Phase 4

Company Name	AeroBridge	Oxford Engineering	VRH Jetworks
Addendum #1	X	X	X
Addendum #2	X	X	X
Addendum #3	X	X	X
Addendum #4	X	X	X
Addendum #5	X	X	X
Lump Sum Bid	\$2,520,000.00	\$2,937,853.00	\$3,457,000.00
Bid Bond	5%	5%	5%
Board of Directors	X	Corporate Acknowledgment	X
Non-Collusion	X	X	X
Qualification Questionnaire	X	X	X
Acknowledgment	X	X	X

I, Kathryn Kane, certify that this bid tabulation is a true copy of the prices submitted by each bidder for the construction project shown above.

Albany Airport Authority Purchasing Department

 Kathryn Kane
 Deputy Purchasing Agent

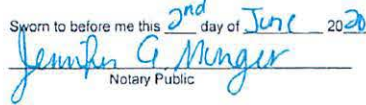
Sworn to before me this 2nd day of June, 2020.

 Notary Public

JENNIFER A. MUNGER
 Notary Public, State of New York
 No. 01MUG246332
 Qualified in Schenectady County
 Commission Expires Aug. 08, 2023

ALBANY COUNTY AIRPORT AUTHORITY
INVITATION FOR BID

Sealed bids are hereby requested by the Albany County Airport Authority for **Contract No. 1039-GC & E for Replacement of Passenger Boarding Bridges A3, A5, B10 & C1 – Phase 4 at Albany International Airport**. This project consists of replacement of passenger boarding bridges at Gates A, A5, B10, and C1 as well as new pre-conditioned Air and Ground Power Units at the impacted bridges. Additionally included is the removal and salvage of Over the Wing Boarding Bridges at Gates C2 and C3. Bid DOCUMENTS MAY BE OBTAINED beginning at 10:00 AM on **May 7, 2020**, from Bid Net Direct by visiting www.bidnetdirect.com/albany-county-airport-authority or AT THE ALBANY COUNTY AIRPORT AUTHORITY PURCHASING OFFICE for a non-refundable fee of \$75.00. No bid shall be considered unless the organization making the bid has first obtained a copy of the IFB. This project has a Disadvantaged Business Enterprise (DBE) goal of 7.4%. In accordance with State Finance Law §§139-j and 139-k, this solicitation includes and imposes certain restrictions on communications between the Airport Authority and an Offerer/bidder during the procurement process. An Offerer/bidder is restricted from making contacts from the earliest notice of intent to solicit offers by this solicitation through final award and approval of the Procurement Contract by the Authority (“restricted period”) to other than designated staff unless it is a contact that is included among certain statutory exceptions set forth in State Finance Law §139-j(3)(a). Designated staff, as of the date hereof, is Bobbi Matthews, Purchasing Agent. Authority employees are also required to obtain certain information when contacted during the restricted period and make a determination of the responsibility of the Offerer/bidder pursuant to these two statutes. Certain findings of non-responsibility can result in rejection for contract award and in the event of two findings within a 4 year period the Offerer/bidder is debarred from obtaining governmental Procurement Contracts. Further information about these requirements can be found by request to the designated staff and the New York State Office of General Services Advisory Council on Procurement Lobbying Web site at: <https://www.ogs.ny.gov/acpl/>. A non-mandatory pre-bid meeting will be held on **May 18, 2020 at 9:00 A.M.** in the Albany County Airport Authority Conference Room, located in the Administration Building, Second Floor at Albany International Airport. All interested parties **MUST** pre-register for this meeting by emailing the Airport Purchasing Agent at bmatthews@albanyairport.com or call 518-242-2213. In order to comply with social distancing, the Authority may schedule a second pre-bid meeting. Only those bids in the hands of the ALBANY COUNTY AIRPORT AUTHORITY, PURCHASING OFFICE, ADMINISTRATION BUILDING, ROOM 204, SECOND FLOOR, ALBANY, NEW YORK 12211 at **2:00 P.M. (EST) May 28, 2020**, shall be considered. Bids shall be opened and read at such time. Bidders will not physically attend the bid opening. Bidders may listen via telephonic mean. Instructions will be distributed to bidders. This opening will be recorded and available upon request to the Airport Authority Purchasing Department. DBE RESPONSES ARE ENCOURAGED.



C&S Companies
499 Col. Eileen Collins Blvd.
Syracuse, NY 13212
p: (315) 455-2000
www.cscos.com

June 4, 2020

John LaClair, P.E., G.G.P.
Airport Engineer
Albany County Airport Authority
Albany, NY 12211

Re: Albany County Airport Authority
Passenger Boarding Bridge Improvements – Phase 4
General Construction Contract

File: Q23.008.001

Dear Mr. LaClair:

Three Bids for the above referenced contract were received on or prior to June 2, 2020 at 11:00 AM. The bids were opened by the Albany County Airport Authority. The bids were tabulated and reviewed by C&S Engineers, Inc. The lowest qualified bid is as follows:

<u>CONTRACTOR</u>	<u>BID AMOUNT</u>
AERO BridgeWorks, Inc. 2700 Delk Road SE, Suite 150 Marietta, GA 30067 PH: (770) 423-4200	Base Bid \$2,520,000

The bid was reviewed by C&S Engineers, Inc. and found to be in order. For a complete breakdown of the bid amounts and the remaining bidders, please refer to the attached bid tabulation.

C&S performed a search of AERO BridgeWorks, Inc. and determined that they do not have an active exclusion. In addition, we have verified that the low bidder is not on the NYSDOL List of Debarred Contractors.

The Contractor was contacted and stated that they were comfortable with the amount of their bid and would stand by it if awarded. The low bidder has completed similar work at airports across the Country. The Bid Documents were reviewed and found to be competent and had completed DBE participation forms.

Based on our review of information submitted, we recommend award of the Contract for Base Bid and allowance in the amount of \$2,520,000 to AERO BridgeWorks, Inc. in accordance with the conditions of award stipulated in their bid and contingent upon the following:

Mr. John LaClair
June 3, 2020
Page 2

1. Receipt of financial statement required in item 10 of Bidder's Qualification Questionnaire

If you agree with our recommendation of award please feel free to utilize the enclosed sample Notice of Award letter. Please contact us should you disagree with our recommendation and decide not to award to AERO BridgeWorks, Inc. We will be happy to discuss your options within the Contract Documents. Please note as per Part 17 of the Information to Bidders in the Project Manual; the Authority has 45 days to award the contract from the bid opening date of June 2, 2020.

If you have any questions or need additional information, please do not hesitate to contact me.

Very truly yours,



I
Principal Architect

AIA

AGENDA ITEM NO. 10.2

**Authorization to Award Construction
Contract 1039-E Passenger Boarding Bridge
Improvements to AERO Bridgeworks, Inc.**

AGENDA ITEM NO: 10.2
MEETING DATE: June 8, 2020

ALBANY COUNTY AIRPORT AUTHORITY
REQUEST FOR AUTHORIZATION

DEPARTMENT: *Planning and Engineering*
Contact Person: *John LaClair, P.E., Chief Engineer*

**ACAA Approved
06/08/2020
Contingent on FAA
concurrence and
compliance with
Apprenticeship
Program**

PURPOSE OF REQUEST:

Construction Contract: *Authorization to Award Construction Contract 1039-E
Passenger Boarding Bridge Improvements to AERO
Bridgeworks, Inc.*

CONTRACT AMOUNT:

Base Amount \$694,000.00

BUDGET INFORMATION:

Federal Airport Improvement Program
Anticipated in Current ALB Capital Plan: Yes ✓ No ___ NA
Funding Account No.: CPN 2251

AWARD CONDITIONS MET:

Apprenticeship Pending *DBE* Y *MWBE* N/A

Service Disable Veteran Owned Business (SDVOB) N/A

FISCAL IMPACT - FUNDING (Dollars or Percentages)

Federal 90% CARES Act 10%
Term of Funding: 2020-2021
Grant No.: 3-36-0001-142-2020 STATE PIN: pending

JUSTIFICATION:

Request to award Contract 1039-E for Passenger Boarding Bridge Improvements on Gates A3, A5, B10 & C1 programmed under the Federal FFY 2020 Airport Improvement Program passenger entitlement program, to qualified low bidder AERO Bridgeworks, Inc. of Marietta, GA for \$694,000.00 Base Bid. The contract scope includes all electrical removal and replacement of electrical equipment for passenger boarding bridges A-3, A-5, B-10 & C-1 and the removal of the Over the Wing (OTW) bridges at gates C-2 & C-3. The existing passenger boarding bridges are over 20 years old and the maintenance costs to keep them operational increases annually. New bridge installation will include removal of the existing unit and installation of a newly fabricated unit at each location. Award contingent upon FAA concurrence and compliance with Apprenticeship Program.

AGENDA ITEM NO: 10.2
MEETING DATE: June 8, 2020

CHIEF EXECUTIVE OFFICER'S RECOMMENDATION:

Recommend approval.

FINAL AGREEMENT SUBJECT TO APPROVAL BY COUNSEL: YES ✓ NA _____

PROCUREMENT DEPARTMENT APPROVAL:

Procurement complies with Authority Procurement Guidelines and Chief Financial Officer has approved. YES ✓ NA _____

BACK-UP MATERIAL:

Please refer to the attached Contract 1039-E Bid Table, Bid Offering and C & S Engineer's Letter of Recommendation for Award.

ALBANY COUNTY AIRPORT AUTHORITY
INVITATION FOR BID

Sealed bids are hereby requested by the Albany County Airport Authority for **Contract No. 1039-GC & E for Replacement of Passenger Boarding Bridges A3, A5, B10 & C1 – Phase 4 at Albany International Airport**. This project consists of replacement of passenger boarding bridges at Gates A, A5, B10, and C1 as well as new pre-conditioned Air and Ground Power Units at the impacted bridges. Additionally included is the removal and salvage of Over the Wing Boarding Bridges at Gates C2 and C3. Bid DOCUMENTS MAY BE OBTAINED beginning at 10:00 AM on **May 7, 2020**, from Bid Net Direct by visiting www.bidnetdirect.com/albany-county-airport-authority or AT THE ALBANY COUNTY AIRPORT AUTHORITY PURCHASING OFFICE for a non-refundable fee of \$75.00. No bid shall be considered unless the organization making the bid has first obtained a copy of the IFB. This project has a Disadvantaged Business Enterprise (DBE) goal of 7.4%. In accordance with State Finance Law §§139-j and 139-k, this solicitation includes and imposes certain restrictions on communications between the Airport Authority and an Offerer/bidder during the procurement process. An Offerer/bidder is restricted from making contacts from the earliest notice of intent to solicit offers by this solicitation through final award and approval of the Procurement Contract by the Authority (“restricted period”) to other than designated staff unless it is a contact that is included among certain statutory exceptions set forth in State Finance Law §139-j(3)(a). Designated staff, as of the date hereof, is Bobbi Matthews, Purchasing Agent. Authority employees are also required to obtain certain information when contacted during the restricted period and make a determination of the responsibility of the Offerer/bidder pursuant to these two statutes. Certain findings of non-responsibility can result in rejection for contract award and in the event of two findings within a 4 year period the Offerer/bidder is debarred from obtaining governmental Procurement Contracts. Further information about these requirements can be found by request to the designated staff and the New York State Office of General Services Advisory Council on Procurement Lobbying Web site at: <https://www.ogs.ny.gov/acpl/>. A non-mandatory pre-bid meeting will be held on **May 18, 2020 at 9:00 A.M.** in the Albany County Airport Authority Conference Room, located in the Administration Building, Second Floor at Albany International Airport. All interested parties **MUST** pre-register for this meeting by emailing the Airport Purchasing Agent at bmatthews@albanyairport.com or call 518-242-2213. In order to comply with social distancing, the Authority may schedule a second pre-bid meeting. Only those bids in the hands of the ALBANY COUNTY AIRPORT AUTHORITY, PURCHASING OFFICE, ADMINISTRATION BUILDING, ROOM 204, SECOND FLOOR, ALBANY, NEW YORK 12211 at **2:00 P.M. (EST) May 28, 2020**, shall be considered. Bids shall be opened and read at such time. Bidders will not physically attend the bid opening. Bidders may listen via telephonic mean. Instructions will be distributed to bidders. This opening will be recorded and available upon request to the Airport Authority Purchasing Department. DBE RESPONSES ARE ENCOURAGED.

CONTRACT #1039-E

Replacement of Passenger Boarding Bridges A3, A5, B10 & C1 - Phase 4

Company Name	AeroBridge Works Inc.	Kasselman Electric Co.	Oxford Engineering
Addendum #1	X	X	X
Addendum #2	X	X	X
Addendum #3	X	X	X
Addendum #4	X	X	X
Addendum #5	X	X	X
Lump Sum Bid	\$694,000.00	\$1,097,981.00	\$810,106.00
Bid Bond	5%	Check	5%
Board of Directors	X	X	Corporate Acknowledgment
Non-Collusion	X	X	X
Qualification Questionnaire	X	X	X
Acknowledgment	X	X	X

I, Kathryn Kane, certify that this bid tabulation is a true copy of the prices submitted by each bidder for the construction project shown above.

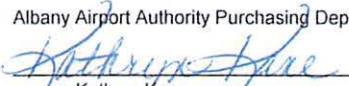
Albany Airport Authority Purchasing Department

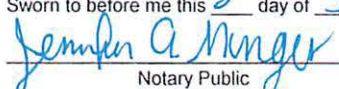
 Kathryn Kane
 Deputy Purchasing Agent

Sworn to before me this 2nd day of June 2020

 Jennifer A. Munger
 Notary Public

JENNIFER A. MUNGER
 Notary Public, State of New York
 No. 01MU6246332
 Qualified in Schenectady County
 Commission Expires Aug. 08, 2023



C&S Companies
499 Col. Eileen Collins Blvd.
Syracuse, NY 13212
p: (315) 455-2000
www.cscos.com

June 4, 2020

John LaClair, P.E., G.G.P.
Airport Engineer
Albany County Airport Authority
Albany, NY 12211

Re: Albany County Airport Authority
Passenger Boarding Bridge Improvements – Phase 4
Electrical Construction Contract

File: Q23.008.001

Dear Mr. LaClair:

Three Bids for the above referenced contract were received on or prior to June 2, 2020 at 11:00 AM. The bids were opened by the Albany County Airport Authority. The bids were tabulated and reviewed by C&S Engineers, Inc. The lowest qualified bid is as follows:

<u>CONTRACTOR</u>	<u>BID AMOUNT</u>
AERO BridgeWorks, Inc. 2700 Delk Road SE, Suite 150 Marietta, GA 30067 PH: (770) 423-4200	Base Bid \$694,000

The bid was reviewed by C&S Engineers, Inc. and found to be in order. For a complete breakdown of the bid amounts and the remaining bidders, please refer to the attached bid tabulation.

C&S performed a search of AERO BridgeWorks, Inc. and determined that they do not have an active exclusion. In addition, we have verified that the low bidder is not on the NYSDOL List of Debarred Contractors.

The Contractor was contacted and stated that they were comfortable with the amount of their bid and would stand by it if awarded. The low bidder has completed similar work at airports across the Country. The Bid Documents were reviewed and found to be competent and had completed DBE participation forms.

Based on our review of information submitted, we recommend award of the Contract for Base Bid and allowance in the amount of \$694,000 to AERO BridgeWorks, Inc. in accordance with the conditions of award stipulated in their bid and contingent upon the following:

Mr. John LaClair
June 4, 2020
Page 2

1. Receipt of financial statement required in item 10 of Bidder's Qualification Questionnaire

If you agree with our recommendation of award please feel free to utilize the enclosed sample Notice of Award letter. Please contact us should you disagree with our recommendation and decide not to award to AERO BridgeWorks, Inc. We will be happy to discuss your options within the Contract Documents. Please note as per Part 17 of the Information to Bidders in the Project Manual; the Authority has 45 days to award the contract from the bid opening date of June 2, 2020.

If you have any questions or need additional information, please do not hesitate to contact me.

Very truly yours,



Principal Architect

, AIA

AGENDA ITEM NO. 10.3

**Construction Contract: Authorization to
Award Construction Contract 1009-PAV
Long Term and Employee Parking Lot
Paving to New Castle Paving**

AGENDA ITEM NO: 10.3
MEETING DATE: June 8, 2020

ALBANY COUNTY AIRPORT AUTHORITY
REQUEST FOR AUTHORIZATION

DEPARTMENT: *Planning and Engineering* *ACAA Approved
06/08/2020
Contact Person: *John LaClair, P.E., Chief Engineer*

PURPOSE OF REQUEST:

Construction Contract: *Authorization to Award Construction Contract 1009-PAV
Long Term and Employee Parking Lot Paving to New Castle
Paving*

CONTRACT AMOUNT:

Base Amount \$195,892.00

BUDGET INFORMATION:

Anticipated in Current ALB Capital Plan: Yes ✓ No NA
Funding Account No.: CPN 2261

AWARD CONDITIONS MET:

Apprenticeship Y DBE N/A MWBE Pending

Service Disable Veteran Owned Business (SDVOB) N/A

FISCAL IMPACT - FUNDING (Dollars or Percentages)

Federal 0% State 0% Airport 100%
Term of Funding: 2019-2021
Grant No.: N/A STATE PIN: N/A

JUSTIFICATION:

Request to award Contract 1009-PAV for Long Term and Employee Parking lots to qualified low bidder New Castle Paving of Troy, NY for \$195,892.00. The contract scope includes removal (milling) of 2" of the existing pavement, cleaning and tack coating of the surface and paving the areas with 2" of Hot Mix Asphalt. The award of this contract is contingent on compliance with the M/WBE requirements.

CHIEF EXECUTIVE OFFICER'S RECOMMENDATION:

Recommend approval.

*Contingent upon compliance with M/WBE requirements. In addition each successful contractor and subcontractor utilized by the successful bidder, which are performing work shall have an apprenticeship agreement appropriate for the type and scope of work performed in all trades that has been registered with and approved by the NYS Commissioner of Labor.

AGENDA ITEM NO: 10.3
MEETING DATE: June 8, 2020

FINAL AGREEMENT SUBJECT TO APPROVAL BY COUNSEL: YES ✓ NA _____

PROCUREMENT DEPARTMENT APPROVAL:

Procurement complies with Authority Procurement Guidelines and Chief Financial Officer has approved. YES ✓ NA _____

BACK-UP MATERIAL:

Please refer to the attached Contract 1009-PAV Bid Table and Bid Offering.

CONTRACT #1009-PAV
Terminal Parking Solar Canopy Improvements and Paving

Company Name	DeiSignore Blacktop Paving	Callanan Industries	Best Paving	New Castle Paving	HMA Contracting
Addendum #1	X	X	X	X	X
Addendum #2	X	X	X	X	X
Lump Sum Bid	\$234,800.00	\$226,543.21	\$252,750.00	\$195,892.00	\$336,100.00
Bid Bond	5%	5%	5%	5%	5%
Board of Directors	X	X	X	N/A	X
Non-Collusion	X	X	X	X	X
Qualification Questionnaire	X	X	X	X	X
Acknowledgment	X	X	X	N/A	X

I, Bobbi Matthews, certify that this bid tabulation is a true copy of the prices submitted by each bidder for the construction project shown above.

Albany Airport Authority Purchasing Department

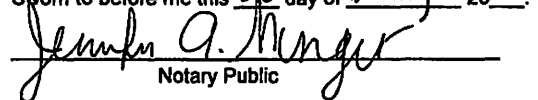

Bobbi Matthews
Purchasing Agent

Sworn to before me this 26th day of May, 2020

Notary Public

JENNIFER A. MUNGER
Notary Public, State of New York
No. 01MU6246332
Qualified in Schenectady County
Commission Expires Aug. 08, 2023

ALBANY COUNTY AIRPORT AUTHORITY
INVITATION FOR BID

Sealed bids are hereby requested by the Albany County Airport Authority for **Contract No. 1009-PAV for the Terminal Parking Solar Canopy Paving at Albany International Airport**. This project consists of cold-milling (2" depth), cleaning, tack coating and paving (2" of DOT Type 6 asphalt) approx. 14, 800 SY in the Long Term Parking Lot between the Entrance and Exit lanes and Approx. 10,400 SY in the Employee Parking Lot West of the Terminal at Hockey Lane. Bid DOCUMENTS MAY BE OBTAINED beginning at 10:00 AM on **May 11, 2020**, from Bid Net Direct by visiting www.bidnetdirect.com/albany-county-airport-authority or AT THE ALBANY COUNTY AIRPORT AUTHORITY PURCHASING OFFICE for a non-refundable fee of \$75.00. No bid shall be considered unless the organization making the bid has first obtained a copy of the IFB. In accordance with Article 15A of the Executive Law, this project includes a combined Minority Owned Business Enterprise Participation and Woman Owned Business Enterprise Participation goal of thirty percent (30%). A participation goal of (6%) six percent for Service Disable Veterans is requested for this project. In accordance with State Finance Law §§139-j and 139-k, this solicitation includes and imposes certain restrictions on communications between the Airport Authority and an Offerer/bidder during the procurement process. An Offerer/bidder is restricted from making contacts from the earliest notice of intent to solicit offers by this solicitation through final award and approval of the Procurement Contract by the Authority ("restricted period") to other than designated staff unless it is a contact that is included among certain statutory exceptions set forth in State Finance Law §139-j(3)(a). Designated staff, as of the date hereof, is Bobbi Matthews, Purchasing Agent. Authority employees are also required to obtain certain information when contacted during the restricted period and make a determination of the responsibility of the Offerer/bidder pursuant to these two statutes. Certain findings of non-responsibility can result in rejection for contract award and in the event of two findings within a 4 year period the Offerer/bidder is debarred from obtaining governmental Procurement Contracts. Further information about these requirements can be found by request to the designated staff and the New York State Office of General Services Advisory Council on Procurement Lobbying Web site at: <https://www.ogs.ny.gov/acpl/>. A non-mandatory pre-bid meeting will be held on **May 20, 2020 at 9:00 A.M.** in the Albany County Airport Authority Conference Room, located in the Administration Building, Second Floor at Albany International Airport. All interested parties **MUST** pre-register for this meeting by emailing the Airport Purchasing Agent at bmatthews@albanyairport.com or call 518-242-2213. In order to comply with social distancing, the Authority may schedule a second pre-bid meeting. Only those bids in the hands of the ALBANY COUNTY AIRPORT AUTHORITY, PURCHASING OFFICE, ADMINISTRATION BUILDING, ROOM 204, SECOND FLOOR, ALBANY, NEW YORK 12211 at **2:00 P.M. (EST) May 28, 2020**, shall be considered. Bids shall be opened and read at such time. Bidders may listen via telephonic mean. Instructions will be distributed to bidders. This opening will be recorded and available upon request to the Airport Authority Purchasing Department. MWBE/SDVOB RESPONSES ARE ENCOURAGED.

AGENDA ITEM NO. 10.4

**Professional Services: Authorization to
Award Contract S-1042 with CHA
Consulting, Inc. for Preparation of the
Airport Master Plan**

AGENDA ITEM NO: 10.4
MEETING DATE: June 8, 2020

ALBANY COUNTY AIRPORT AUTHORITY
REQUEST FOR AUTHORIZATION

ACAA Approved
06/08/2020
Contingent on satisfaction
of Federal DBE program
compliance, FAA Contract
Concurrence and AIP
Grant issuance.

DEPARTMENT: *Planning and Engineering*

Contact Person: *Stephen Iachetta, AICP, Airport Planner*

PURPOSE OF REQUEST:

Professional Services: *Authorization to Award Contract S-1042 with CHA Consulting, Inc. for Preparation of the Airport Master Plan*

CONTRACT AMOUNT:

Base Amount: \$749,965

BUDGET INFORMATION:

Anticipated in Current Capital Plan: Yes No NA
Funding Account No: CPN 2290

FISCAL IMPACT - FUNDING (Dollars or Percentages)

Federal 90% CARES Act 10% Airport 0%
Term of Funding: 2020-2022
Grant No. 3-36-0001-141-20 ; NYS DOT PIN – NA.

JUSTIFICATION:

Authorization is requested to award professional engineering service Contract S-1042 with CHA Consulting, Inc. of Albany as recommended by the ACAA Selection Committee and authorized for negotiations at the May 4 Board meeting. Negotiations have been completed following FAA guidance of Advisory Circular No. 150/5100-14E "Architectural, Engineering and Planning Consultant Services for Airport Grant Projects. The last full FAA Airport Master Plan was completed in 1979 with a comprehensive Airport Layout Plan Update completed in 1998 by CHA to support Terminal and Air Cargo Improvements completed in 2002. Award will be contingent on satisfaction of Federal DBE program compliance, FAA Contract Concurrence and AIP grant issuance. Funding is programmed with FAA as AIP Entitlement grant #3-36-0001-141-2020 with a 90% funding allocation and CARES Act supporting the former State and Airport 10% funding share, \$74,996 of the \$749,965 total contract.. There is no State nor ACAA funding share as programmed.

CHIEF EXECUTIVE OFFICER'S RECOMMENDATION:

Recommend approval.

AGENDA ITEM NO: 10.4
MEETING DATE: June 8, 2020

FINAL AGREEMENT SUBJECT TO APPROVAL BY COUNSEL: YES NA _____

PROCUREMENT DEPARTMENT APPROVAL:

Procurement complies with Authority Procurement Guidelines and Chief Financial Officer has approved. Yes NA _____

BACK-UP MATERIAL:

Please refer to the attached CHA Scope and Fee Proposal.

**AIRPORT MASTER PLAN UPDATE
ALBANY INTERNATIONAL AIRPORT (ALB)**

**SCOPE OF WORK (6-3-2020)
Contract S-1042**



INTRODUCTION

This Scope of Work was developed consistent with the guidance provided in Federal Aviation Administration (FAA) Advisory Circular (AC) 150/5070-6B, *Airport Master Plans*. The outcome of the Study will provide planning and development guidance necessary to address landside and airside facilities and land development considerations for the next 20 years and beyond.

TASK 1: PROJECT MANAGEMENT AND ADMINISTRATION

1.1. Project Definition and Scoping

The scope of services for the Study will be prepared by CHA Consulting, Inc. (the "Consultant") and project subconsultants (the "Consultant Team") and reviewed by the Albany County Airport Authority ("ACAA") and FAA. Following this review, the program will be further detailed and the level of effort and associated costs of accomplishing each component of this planning effort will be identified. Work activities under this task will include:

- Meetings/discussions with ACAA staff, FAA, and study subconsultants;
- Preparation of draft study scope, budget, and schedule; and
- Preparation of final work program, budget, and schedule for approval.

The Consultant Team will meet with ACAA to develop the study scope and procedures. Administrative issues will be discussed, and any questions addressed. A product of these meetings will be a final study scope of work and a description of management and administrative procedures to be followed (i.e., invoicing, memoranda format, media relations, communication protocols, etc.).

1.2. Kickoff Meeting & Working Schedule

The Consultant Team will hold a working session with ACAA to kickoff the study effort, review the project scope of work, and set procedures to be used throughout the planning study. The meeting will also discuss and refine the project schedule with the assistance of ACAA. This schedule will be agreed to by all parties and will be used as a benchmark of study progress. Any adjustment to the study procedures and schedule will be documented.

During the kickoff meeting, the Consultant will provide a list of existing relevant plans and reports to be provided, as well as a checklist of requested data (e.g., flight schedules, parking records, financial data, etc.).

1.3. Project Administration

The Consultant will develop and submit monthly progress reports for each active task during the reporting period. For each task, the progress reports will identify completed activities, schedule and financial status, issues encountered, and activities anticipated to be accomplished during the next reporting period. Progress reports will accompany the monthly invoices in a format specified by

ACAA. In addition, informal monthly meetings/teleconferences are suggested to discuss study activity and meeting schedule. Subconsultants will participate in these meetings as needed.

The Consultant will be responsible to oversee activities of all subconsultants, including DBE firms. Responsibilities include executing agreements, processing invoices, and documenting participation of DBE firms (via payment records). All required management and administration of subcontracts necessary for the project is included in this subtask.

Relevant technical data, drawings, and reports will be maintained by the Consultant and delivered to the ACAA at the completion of the study. Management and financial records will be maintained for possible review or audit for a period of three years following the completion of the contract.

The Consultant will maintain study files for this project that will include technical submissions, meeting notes, and key correspondence. The information prepared for the study will document methodologies and procedures used.

TASK 2: AIRPORT INVENTORY

This task will include a collection of existing available information and studies, field review of airport facilities, and meetings and interviews with airport staff and tenants. The product is a detailed overview of ALB for 2020 (current conditions).

2.1. Inventory of Airport Facilities

2.1.1. Inventory of Airfield Facilities

A comprehensive inventory of existing airfield facilities at ALB will be conducted. This inventory effort will include a desk-top review of runways, taxiways, aprons, lighting, marking, signage, landing aids, and navigational aids. Information will be gathered from discussions with ACAA staff, review of existing drawings and photographs, and from limited onsite visual inspection. It is understood that this information will be provided by ACAA and will only require review and refinement by the Consultant Team. In addition, the Consultant Team will collect and review existing pavement information provided by ACAA. It is understood that this data is available for incorporation into the master plan and ACIP and no new information will need to be generated. Problem areas and conditions will be considered in the development plans and financial plan.

2.1.2. Inventory of Passenger Terminal Facilities

Existing reports and studies pertaining to the Commercial Passenger Terminal facilities will be provided by ACAA prior to commencing this task and reviewed by the Consultant. Such documents, including terminal floorplans, will provide essential background and reference information for the project understanding of existing and projected terminal development activities, as well as provide insight into relevant planning issues and constraints. These previous and on-going programs will be utilized, to the greatest extent possible, as integral components of this Master Plan.

The Consultant Team will review existing data, studies, and schematics. A limited (one day) on-site observation of the existing terminal building conditions will be conducted to establish a general understanding of the current space utilization and operational characteristics. The Consultant will review the existing public and non-public areas of the terminal complex, with an emphasis on the security checkpoint. ACAA will provide the Consultant Team with electronic

CADD files of the terminal complex, including floorplans, as well as on-going studies and improvements to the existing terminal. These will be provided prior to initiating work. Documentation on the existing facilities will be reviewed, but not verified for accuracy. The Consultant may provide additional services to measure portions of the building solely for the purpose of verifying certain conditions. Under certain circumstances, (e.g., if the documentation of existing conditions is unavailable or appears to be unreliable) the Consultant may recommend a survey to document the existing conditions before proceeding with the planning activities.

The Consultant will review the materials relative to a variety of terminal functional areas, such as curb frontage, check-in counter utilization, SSCP utilization, gate/holdroom utilization, and baggage (inbound and outbound) utilization. The passenger corridor circulation, holdroom seating, airline lounges, and concession areas shall be reviewed (no survey or active data collection will be conducted). The intent of this subtask is to develop a general understanding of the current terminal building and its associated facilities.

2.1.3. Inventory of Support Facilities

An inventory of the various support facilities will be conducted. The support facilities to be inventoried will include, but are not limited to:

- Air Cargo Facilities
- General Aviation Facilities/FBO
- Aircraft Refueling Stations/Operations
- Aircraft Rescue and Fire Fighting (ARFF) Facilities
- Airfield Maintenance Facilities

2.2. Inventory of Operations, Airspace, and Air Traffic Control Procedures

2.2.1. Inventory of Air Traffic and Passenger Activity

Current data on passenger, cargo, and aircraft activities (e.g., air carrier, charter, cargo, general aviation, and military) at ALB will be collected to develop a profile of airport operations, including changes in use and levels of operations in recent years. Data sources will include but not be limited to FAA Air Traffic Statistics; Tower Airport Statistics Handbook; Statistical Handbook of Aviation; FAA Form 5010-1 and Terminal Area Forecasts; and ALB monthly and annual activity summaries.

2.2.2. Conduct Airfield Use Evaluation

An airfield use review will be conducted to identify runway and taxiway use patterns. Additionally, interviews with operations personnel will be conducted to identify operating procedures and assumptions. These procedures and assumptions will provide the framework for the future airfield facility requirements.

The following information, as available, will be collected for use in this effort: historical operations data; control tower logs; Standard Operating Procedures; and airline flight schedules. Historic ALB wind data obtained from the National Weather Service will be compiled and reviewed to calculate runway wind coverage. The data collected in this task will develop an inventory of operating practices and procedures at the Airport.

2.3. Interviews of Stakeholders

Information regarding key aviation activity drivers will be collected and organized by the Consultant Team. This process may include, but not be limited to, interviews with ACAA management, management contractors, and airport tenants to solicit opinions regarding satisfaction of present facility needs and perceived future aviation needs at ALB and the surrounding area. ACAA staff, management contractors, and FBOs will be queried regarding their perceptions of aviation trends in the region as well as their specific plans.

In addition to the data collection efforts of Task 2.2, the Consultant Team may survey select airport stakeholders including:

- *Terminal Tenants:* Discussions may be held with ALB airline station managers, TSA, rental car concessionaires, retail concessionaries, ground transportation operators, or their representatives, as available, to discuss their facilities, plans, and considerations for their activity at ALB. Stakeholder discussions and interviews will be half-hour blocks of meetings as scheduled in a contiguous two-day period, after stakeholders have had an opportunity to review and respond to any questionnaires sent thru the ACAA in advance.
- *FBO, Key Tenants, and Other Users:* Discussions will be held with the FBOs, key tenants, and other property lease holders. Questions will focus on their future plans and needs, activity, and changes in their business and operations.
- *Airlines:* Discussions may be held with the current airlines serving ALB to identify concerns related to current economic considerations and anticipated changes to aircraft fleet mix and passenger demand. Stakeholder discussions and interviews will be as scheduled in a contiguous two-day period, after stakeholders have had an opportunity to review and respond to any questionnaires sent thru the ACAA in advance.
- *Cargo Carriers:* Discussions will be held with FedEx and UPS to identify current and anticipated plans at ALB.
- *Airport Operations Personnel:* Discussions with airport staff and operations personnel will be held to identify existing concerns related to day-to-day airfield maintenance and or concerns that may be unique to ALB.
- *Air Traffic Control Personnel:* Discussions with ALB air traffic control personnel will be held to discuss airspace considerations at and surrounding ALB.

The Consultant Team will attempt to conduct the interviews during a two-day period. However, it is anticipated that some stakeholder input will be provided by use of a survey form and telephone follow-up, as needed. The goal of this effort is to identify information useful in the facility requirement and alternatives tasks.

2.4. Socio-Economic Data

Socio-economic data for the region will be collected and analyzed to identify trends that may impact the aviation forecasts. Woods and Poole Economic Data will be purchased and used as the basis for this analysis and will be supplemented by available regional data. This data may be used directly or indirectly to inform the forecast and will be summarized at the beginning of the forecast document to provide a snapshot of the current socio-economic trends in the Capital Region.

2.5. Inventory of Existing Parking Facilities

An inventory of existing conditions will develop baseline information to be used in the planning effort, including transaction, revenue, and peak occupancy, as available. The Consultant will compile any available data to develop a profile of public parking activity. This data will be used as a foundation for the parking demand model.

Parking information will include the number of parking spaces within walking distance of the terminal, parking rates, number of rental car ready and return spaces, airport and private shuttle parking, etc. The existing landside area will be reviewed based on customer service and revenue generation, both in terms of industry standards.

2.6. Passenger Ground Access Model

The Consultant Team will summarize historical activity data provided by the ACAA describing how passengers arrive to and depart from the Airport. These are likely to include parking transactions by facility, rental car transactions or revenue, commercial vehicle transactions via an AVI system output, self-reported transportation network company (TNC) transactions, and public transit schedules information. A ground access model will be developed at a monthly level for the past two years, which illustrates how TNCs have impacted ground access market shares at the Airport. The Consultant will lead a discussion with the ACAA to determine future ground access assumptions to be used in the requirements analysis.

2.7. Development of Airport Layout Plan Base Map

Airport facilities will be represented on the Existing Airport Layout Plan (ALP) base map. The most current versions of both of these base maps will be provided by the ACAA. Technical personnel will confirm with ACAA staff on the procedures for preparation of the digital records. Agreement on the materials to be digitized, the changes to be made, and the layering of the data will be discussed. The ACAA will supply to the Consultant base mapping/planimetric data and aerial imagery in electronic CADD format from their recently (2017) completed AGIS project.

TASK 3: FORECASTS OF AVIATION DEMAND

The following elements will be included in this task, which develops the 5, 10, and 20-year planning horizons at ALB. The forecasts that will be used through the remainder of the study for developing facilities requirements and identifying “trigger points” for airport investments and improvements.

Historical aviation activity data and present activity will also be collected from the FAA Terminal Area Forecast (TAF) and the Official Airline Guide (OAG) scheduled flight information.

3.1. Aviation Forecasts

The Consultant Team will use the FAA’s official Terminal Area Forecast (TAF) released in January 2020, or as revised by FAA, as the basis for the aviation activity forecasts for ALB for the short- (5 years), intermediate- (10 years), and long-term (20 years). No consideration will be given to loss of activity due to the COVID-19 pandemic, and no future activity scenarios will be developed to explore recovery options. The TAF will be documented, with derivatives prepared as needed for the following activity types:

- Enplanements
 - Annual domestic and international enplanements
 - Peak month and peak hour enplanements

- Operations
 - Total annual operations
 - Air carrier and air taxi operations (total and by fleet mix)
 - GA operations (total and by fleet mix)
 - GA operations by type (local versus itinerant)
 - Military operations
 - Cargo operations and tonnage
 - Peak month and peak hour operations (total and by type of operation)
- Based Aircraft
 - Based Aircraft by Fleet Mix
 - Critical Aircraft

3.2. FAA & State Coordination

The Consultant Team will prepare an Aviation Forecast chapter for submission to the FAA and NYSDOT for review. The Consultant will prepare for and attend a teleconference meeting with representatives of the ACAA, the NYADO and NYSDOT as necessary.

If new FAA guidance and requirements are established due to the COVID-19 pandemic during the time of the preparation of the forecast but before approval, additional scope and fee will be required in order to attain critical FAA and NYSDOT approval of the aviation activity forecasts, before further demand-driven planning can proceed.

3.3. Develop Future Design Day Flight Schedule

Once the forecast has been approved by the FAA, Design Day Flight Schedules (DDFS) for the base year and one future planning activity level will be developed. The DDFS will be based on the average day peak month departures from the forecast and will include anticipated future changes to aviation activity such as changes in fleet mix and changes in airlines service (new entrants and destinations as well as potential loss of service) anticipated within the planning period. The DDFS will help drive the need for passenger gates as well as the terminal and landside facility requirements. The DDFS will be reviewed and approved by the ACAA, prior to development of terminal gate requirements.

DELIVERABLE: Working Paper No. 1

This Working Paper will include an illustrated inventory of existing facilities and conditions at ALB as well as the comprehensive forecast of aviation demand. It will be provided to ACAA for review and comments, prior to being submitted to the Advisory Committees, and to FAA for review and approval. The approved forecasts are used in Task 4 to determine short and long-term facility requirements.

TASK 4: DEMAND/CAPACITY ANALYSIS AND FACILITY REQUIREMENTS

This task evaluates and identifies the existing and future demands for each airport component and provides the comprehensive determination of airport facility requirements throughout the planning period.

4.1. Determine Airfield Requirements

4.1.1. Airfield Capacity Analysis

With under 100,000 total annual operations currently and anticipated through the planning period, there is no need for a detailed airfield capacity analysis. As such, using the FAA's methodology for assessing airfield capacity and delay as described in FAA AC 150/5060-5, *Airport Capacity and Delay*,

Chapter 2, a brief assessment of the current and future level of airfield capacity will be developed and documented in the study report.

4.1.2. Airport Reference Code and Runway Design Group

Based on the activity forecasts and critical aircraft determination, this task will document the existing and future critical aircraft, as well as the associated Airport Reference Code (ARC) and Runway Design Group (RDG) for both runways. Existing and future airline and air cargo aircraft will be considered in this evaluation. It is noted that large military transport and refueling aircraft conduct regular training activity at ALB; however, these aircraft will not be considered as part of the Facility Requirement evaluation.

Other runway requirements to be addressed include the runway width, strength, configurations, FAA design standards, and clearances from taxiways and structures. Runway Safety Area (RSA) standards will be reviewed, including grades, and available FAA RSA determinations

4.1.3. Crosswind Runway Requirement

The ALB wind information obtained in Task 2, along with forecasted operational data developed as part of Task 3 will also be used to consider the FAA requirement for Crosswind Runway 10-28, including its FAA classification and anticipated use. FAA Order 5100.38D, the AIP Handbook, provides the eligibility requirements for crosswind and secondary runways and will be utilized to document the need for both runways at ALB.

4.1.4. Runway Length & Navigational/Landing Aide Requirements

The purpose of this subtask is to examine the existing runway length and navigational/landing aid facilities and their ability to accommodate current and forecast levels of demand. The Critical Aircraft, in terms of runway length, will be identified for each runway. Runway length requirements for the aircraft expected to use the Airport in the future will be identified for maximum payloads and for a range of stage lengths. In general, the runway length requirements of newer aircraft have been decreasing. As such, it is anticipated that the existing available runway lengths will be adequate throughout the planning period, even for longer stage lengths (i.e., non-stop west coast airline service).

Requirements for instrumentation, lighting, and visual aids will also be identified and compared to current conditions. Any deficiencies will be identified.

4.1.5. Taxiway Requirements and Airfield Geometry

The Consultant Team will evaluate the taxiway requirements with respect to need, safety, and new FAA design standards per changes to FAA AC 150/5300-13A. Based on this analysis, deficiencies will be identified and documented, as necessary. Considerations will include:

- Airfield intersections between runways, taxiways, and aprons
- Listed "hot spots" and line-of-sight conditions
- Direct apron-runway access
- 4 and 5 node intersections
- Surplus pavement areas
- Ambiguous configurations that may increase the potential for incursions

The new Taxiway Design Group (TDG) standard will also be used to determine the taxiway width requirements. The main taxiways at ALB are currently 75 feet wide to support aircraft such as the Boeing 757, in use by FedEx and UPS. Future requirements in the short- and long-term will be identified, including deficiencies in required geometry (e.g., fillets, turn radii, etc.), with sample diagrams and comparison to existing conditions.

4.2. Passenger Terminal Facility

4.2.1. Short-Term (up to 12 months) Passenger Terminal Facility Requirements

The terminal area demand capacity analysis will establish metrics that indicate demand levels below capacity, demand levels approaching capacity, and demand levels exceeding capacity. This review will be based on forecast passenger demand in the next six months up to twelve (recovery period). The passenger terminal facility requirements will be based on the latest best practices in terminal design.

This task will include a review of the capacity of the existing terminal based on available existing documentation.

For this review, the key individual terminal components will be considered, including:

- Ticket counters & facilities
- Security screening checkpoint/ TSA facilities
- Gates (holdrooms) and passenger concourses
- Public Circulation
- Baggage claim hall

4.2.2. Passenger Terminal Facility Planning

The Consultant shall utilize the existing and forecast passenger and aircraft activity to assess current and future terminal facility needs, including peak demands. These metrics will identify 5-year, 10-year, and 20-year planning horizons of existing and projected capacity correlated with planning activity levels. This effort will consider both the currently planned improvements to the existing terminal and the long-term development of the terminal. This task will commence with a review of the capacity of the existing terminal, with implementation of all planned upgrades based on available documentation provided, including the security screening checkpoint, FIS facility, vertical circulation, etc. The intent is to provide adequate space for existing and forecasted passenger volumes and enhance passenger spending while in the terminal.

This review will estimate when, and at what planning horizon, the existing facility will reach its level of service capacity. The critical facility shortfall(s) will be identified. Thereafter, the capacity analysis completed for the planned new terminal complex will be compared to the forecast passenger demand. The need and timing for development of the new complex will be identified.

For this review, the key individual terminal components for their relative space/quantities, will be considered, including:

- Curbside requirements
- Ticket counters & facilities

- Security screening checkpoint/TSA facilities
- Gates and passenger concourses
- Public Circulation
- Concessions program
- Customs and Border Protection (CBP) (as/if required)
- Federal Inspection Services (FIS)
- Inbound and Outbound Baggage handling systems and facilities
- Restrooms (fixture count demand to be estimated by aviation planning method, based on levels of service and average fixture utilization per enplaning/deplaning passenger)
- Airport Operation/Management
- Wayfinding and Signage
- Loading Dock
- Mechanical, Electrical, Plumbing System Spaces (as a percentage of terminal net)

4.2.3. Terminal Gate Requirements

Leveraging the future design day flight schedules (DDFS), the Consultant will provide a hypothetical future aircraft gating plan and ramp chart visualization. The gate plan will respect aircraft gate compatibility, airline allocation, and AIRPORT gate utilization. Additionally, summary statistics such as aircraft departures per gate will be provided and discussed with the ACAA.

4.2.4. Passenger Terminal Building Energy Efficiency Review

This section will include a brief review of the existing passenger terminal building's heating, ventilation, and air conditioning (HVAC) systems for review of energy efficiency and provide assessment of the existing conditions and recommendations of replacements or repairs to address immediate and planned needs. The existing HVAC systems and boilers are 22 years old. The Consultant will evaluate the existing HVAC systems and provide recommendations for upgrading or replacement. CHA will provide alternative options with cost analyses based on the energy efficiency and energy savings for HVAC upgrading or replacement to accommodate the current airport operations with consideration for future expansion of terminal buildings.

4.3. Determine Airport Parking and Curbside Requirements

The Consultant will project future parking demand based on enplanement projections through the 20-year planning horizon. This analysis will identify potential shortfalls in supply based on anticipated conditions, changes in mode split (between private vehicles, parking shuttles and express bus service) and other factors. The demand for and impact of the availability of additional off-site parking will be evaluated.

The Consultant will develop and evaluate requirements to balance parking supply and demand over the 20-year planning horizon. This will include potential expansion of parking supply as well as transportation demand management, as appropriate.

4.3.1. Develop Future Public Parking Requirements

The Consultant will assess historical daily peak and overnight parking demand for at least 12 months to identify the seasonality of parking demands and the typical design-day parking demand by facility. Parking requirements will be based primarily on the observed peak occupancy with allowances for any existing parking constraints. Future requirements will be

based on proportional growth between parking demand and forecast growth in annual originating airline passengers. The estimated public parking requirements will be compared with available parking spaces (including the new Garage) and estimated deficiencies (or surpluses) in available spaces will be identified.

4.3.2. Develop Future Employee Parking Requirements

The Consultant will estimate the existing demand for employee parking, based on available data summarizing peak period parking lot accumulation counts by parking lot location. Future employee parking requirements will be estimated by assuming that employee parking requirements will increase in proportion to the expected annual increase in the expected average growth in originating airline passenger volumes and aircraft activity. The requirements will be compared with available parking spaces and deficiencies/surpluses will be identified.

4.3.3. Develop Future Roadway & Curbside Requirements

The Consultant will project access roadway, circulation roadway and curb front traffic volumes using spreadsheet models to determine future requirements for number of lanes and expected level of service. Future requirements will be compared against existing available capacity to identify anticipated future roadway deficiencies. Due to the decreased activity attributable to COVID-19, no new traffic count data is expected. Therefore, the Consultant Team will rely entirely on historical data provided by the ACAA. If no traffic counts are available, the Team will develop roadway and curbside requirements using peak-hour passengers and assumptions from the ground access model.

4.3.4. Develop Future Rental Car Facility Requirements

The Consultant will prepare a high-level program for rental car facilities based on historical revenues and any available transaction information provided by the ACAA or the RAC tenants. The program will include elements such as ready/return spaces, quick turnaround fuel vacuum and car wash bays. If no tenant activity data is available, the Team will develop RAC requirements using peak-hour passengers and assumptions from the ground access model.

4.4. Evaluate Air Cargo Facility Requirements

Based on the interviews and plans of existing operators, and the forecast of cargo volume/tonnage, the need for additional air cargo facilities will be evaluated, and a demand/capacity analysis will be completed for cargo facilities at ALB. Specific industry methodologies will be used for each support element, considering the unique factors that influence its demand. Facility features to be analyzed include but are not limited to:

- Facility size and age
- Type of equipment
- Number of personnel, and parking spaces

In conjunction with the air cargo forecast analysis this task will compare capacity and future demand and identify future requirements for cargo facilities at the Airport, including but not limited to:

- Aircraft apron space / positions for narrow and wide body aircraft
- Processing/storage facilities
- Truck and Automobile Parking

4.5. Determine Corporate/FBO/General Aviation Requirements

The existing general aviation facilities requirements will be reviewed and compared to the forecasts of based aircraft and fleet mix. Future demand for the base forecast scenario will be used to identify future requirements for general aviation facilities at ALB, including:

- Aircraft parking (ramp, tie-down, hangar, etc.)
- Fixed based operator facilities
- Based corporate aviation facilities
- MRO and other facilities and functions

4.6. Develop Support Facility Requirements

For estimating the size of the Support Facility elements listed below, the Consultant shall use the facility information collected during the inventory phase supplemented with operational elements and space utilizations as provided by ACAA. The support facilities will include the following:

- Aircraft Maintenance Facilities
- FAA Facilities
- Aircraft Rescue and Fire Fighting (ARFF) Facilities
- Aircraft Fueling Systems Facilities

DELIVERABLE: Working Paper No. 2

This Working Paper will include the results of the demand/capacity analysis and recommended facility requirements for ALB.

TASK 5: AIRPORT DEVELOPMENT CONCEPTS

In this task, the Consultant Team will establish the approach and criteria for evaluating airport development concepts in a working session with the ACAA. It is anticipated that evaluation criteria will include the following factors:

- Construction and operating costs (order of magnitude based on unit of area or volume)
- Flexibility (to accommodate future demand and operational fluctuations)
- Convenience of passengers
- Construction impacts, including ease of phasing and construction
- Revenue generating potential
- Airfield access and operational factors
- Environmental impacts

Following the development of the evaluation approach and criteria, the following elements will be analyzed:

5.1. Airfield Improvement Concepts

This subtask will identify and evaluate potential runway and taxiway improvements that will address the overall aircraft flows between the runway system and the various functional areas. Schematic concept drawings and narrative descriptions will be provided for each concept. Runway and taxiway concepts will be screened through qualitative analyses of the following:

- Operational benefits
- Environmental considerations
- Implementation costs/feasibility
- Construction/phasing issues

- Community acceptance

It is anticipated the airfield alternatives will be limited in nature, but will likely include:

- Runway design standard upgrades
- Revised taxiway layouts to address revised FAA Standards
- Configuration changes for the following (and other identified areas):
 - Taxiway C West
 - Taxiway D & G
 - Extension of Taxiway P to Runway 10 end
 - Minor revisions to Taxiways J and K

New runways and runway extension alternatives are not anticipated.

5.2. Passenger Terminal Facility Concepts

5.2.1. Short-Term Terminal Facility

In light of the current changing passenger safety and wellness concerns, the Consultant will develop initial high-level recommendations to implementing changing passenger and processing needs, such as health and safety screening, social distancing, etc. The key finding will be to size and locate the likely facilities, and the ability of the existing passenger terminal to accommodate these anticipated needs and short-term requirements within the next six to twelve months.

5.2.2. Terminal Design Charrette/Visioning

Upon the commencement of Task 5.2., The Consultant will coordinate a virtual design charrette (or visioning session) with the ACAA and any other necessary parties, including the end-user and other parties required to make design decisions. The objective of the design charrette will be to review and discuss the design approach, goals, and objectives in order to establish the design direction for the Project. The Consultant will prepare minutes documenting the discussions and decisions made during the charrette. The minutes will also document any questions and issues which the parties may agree to address at a later stage.

5.2.3. Passenger Terminal Facility

Utilizing the terminal facility requirements developed in Task 4.2. and the design direction from the Design Charrette/Visioning, the Consultant will develop a phased enhancement of the passenger terminal facility to meet forecast demand by horizon in such areas as curbs, check in, security check point, retail, circulation, holdrooms, baggage claim and bag makeup. These shall be developed for planning horizons of 5-, 10-, and 20-years. Based on the goals and objectives and the Design Charrette/Visioning meeting, sustainability aspects shall be incorporated and compared as part of the evaluations.

5.2.4. Initial Terminal Facility Alternatives

The Consultant shall prepare and develop up to two (2) initial terminal alternatives for the long-term (20 years) period, with conceptual sketches of how each alternative may be developed from the near-term/short term through the intermediate term planning horizons. The development of each terminal alternative will focus on the utilization of existing terminal facilities until a point of saturation occurs. This ensures the maximum use of existing facilities up to a point when they must be significantly modified or replaced. The timing and scale of improvements will be based on the

preferred activity forecast and facility requirements as previously developed in Task 4.2. Alternative analysis will include planning level schematics of the alternatives for the purposes of presentation and comparison. Architectural and engineering level schematics will not be prepared. The Consultant will make recommendations related to aesthetic upgrades and full reconstruction depending on the condition and requirements associated with each facility. Consideration for the adaptable reuse of existing facilities (buildings) will be given before extending the current facility footprint.

At the midpoint of the initial terminal alternatives development, the Consultant will present them to ACAA for comment and feedback. The Consultant will refine the alternatives per the input and feedback.

Development of the initial alternatives will be presented by functional blocking and stacking diagrams, identifying key program functional areas and adjacencies.

5.2.5. Preferred Terminal Facility Alternative

The preferred terminal facility alternative will be developed further and refined per input and feedback. As with the initial alternatives, there will be a midpoint and final presentation to ACAA for comment and review.

At this planning stage, Code and Life Safety analysis of the preferred alternative shall be limited to overall strategies and approaches to life safety consistent with the Consultant Team's aviation experience on similar projects and identification of the governing codes and authorities having jurisdiction.

Development of the preferred alternative shall be by developed planning diagrams (assume overall terminal plan representations plotted at a scale of approximately 1:1200/1":100' on 34"x22" sheets) and basic building sections and up to two (2) 3D massing to illustrate building form. Schematic renderings are not included in this scope, and may be provided as an Additional Service, if requested.

5.2.6. Cost Estimates of Preferred Terminal Alternative

Planning level cost estimates, to a rough order of magnitude based on area or volume, will be prepared for the preferred terminal alternative.

5.3. Access and Parking Concepts

5.3.1. Develop Vehicle Parking Concepts

Based on the recommended airfield and terminal alternatives parking alternatives will be developed to meet the anticipated future demand. Alternatives will consider as appropriate the ability to meet the long-term quantity of parking, considerations for different parking products; such as short- and long-term, remote, rental car, and employee parking; and potential future locations for parking expansion as required to meet the facility requirements identified.

5.3.2. Develop Access & Roadway Concepts

Based on the recommended airfield and terminal alternatives, alternatives will be developed for airport roadways and access to the terminal area. Alternatives may consider additional or modified access to the terminal area depending on changes or potential relocations to roads, modifications

to the exit configuration of the terminal area, or other improvements to the flow of vehicles to and from the terminal. Of particular interest will be the new configuration created by traffic exiting the new parking garage and integration with the existing flow. Potential options for this location will be considered.

5.3.3. Develop Terminal Curb and Ground Transportation Alternatives

Based on the recommended terminal alternatives, terminal curb and ground transportation configurations will be prepared. Alternatives may consider additional curb front lanes, potential allocation of curb lanes, or modifications to pedestrian vehicle interactions.

5.3.4. Develop Rental Car Facility Alternatives

Based on the parking expansion concepts, alternatives will be developed to meet the anticipated rental car demand. It is assumed that all alternatives will continue with the current operating environment. Working with the ACAA, a preferred rental car alternative will be recommended.

5.4. General Aviation, Air Cargo, and Support Facility Concepts

The purpose of this subtask will be to add aviation-related support functions to the preferred terminal concept. Conceptual layouts of general locations, sizes, and configurations of general aviation, cargo, support facilities, etc. will be developed. The layouts will reflect the projected facility requirements as well as opportunities for other development.

5.4.1 General Aviation (GA)

Concepts will be based on anticipated demand and will include up to five (5) potential layouts, located in multiple areas of the airport, including on property for potential acquisition. As GA development is typically conducted by airport tenants (not the ACAA), the concepts will be intended to illustrate practical layouts that may be considered, but not the final size of facility siting.

5.4.2 Airline MRO Facilities

ALB currently has two Maintenance, Repair & Overhaul (MRO) facilities operated by regional airlines. Based on needs of these and other airlines, potential facility expansion, or new facility concepts will be identified. Any known airline requirements and aircraft types to be serviced will be incorporated into the development options.

5.4.3 Air Cargo

Currently air cargo operators are supported in the cargo facility in the northeast quadrant of the airport. Based on discussions with existing, or potential additional operators, layout options for expansion, relocations, or new developments will be identified. If the existing facility constraints prevent supporting of future needs, concepts for a second air cargo development area will be identified.

5.4.4 Support Facilities

The planning effort for support facilities will be limited in the master plan, but will include siting for requirements identified by ACAA, or for replacement of any existing development displaced by the master plan recommendations (i.e., existing administration building and equipment garage)

5.5. Final Concept Development

The purpose of this subtask is to integrate each airport development recommendation into an overall recommended improvement program. Combining individual recommendations into the overall plan

may identify additional necessary refinements for compatibility. General factors to be considered for the airside and landside components will include, overall passenger convenience, optimal use of available Airport land, order-of-magnitude construction and operating costs, engineering feasibility, ease of phasing and construction, and environmental impacts.

5.6. Environmental Overview

This subtask includes a brief environmental summary based on existing available studies and data, and to identify potential environmental impacts of the development alternatives and recommendations. The environmental overview will consider a range of environmental concerns associated with the development of ALB and identify those which may warrant further analysis prior to project implementation. Previous environmental evaluations conducted for the Airport will be utilized. The range of potential environmental concerns will be considered based on FAA Order 5050.4B, *National Environmental Policy Act (NEPA) Implementing Instructions for Airport Projects* and FAA Order 1050.1F: *Environmental Impacts: Policies & Procedures*.

Based on the Consultant's experience at ALB, key considerations will include the following:

- *Water Quality and Drainage (floodplains):* Shaker Creek transverses the airport property, include it unnamed tributaries that drain the airport property. High water table and standing water, including within the Runway Safety Area have been an issue addressed by the airport. The Consultant will review existing drainage evaluations and improvements completed by CHA and others, to identify any potential impacts of the development alternatives.
- *Wetlands:* Several portions of the airport property have been field-delineated in the past, and all areas of the airport and adjacent property have been generally mapped for wetland and hydric soils by USACOE and NYSDEC. The Consultant will review existing wetland delineations completed by CHA and others, to identify any potential impacts of the development alternatives.
- *Endangered and Threatened Species:* This task will include review of existing data available from regulatory agencies to identify any recent changes in species on concern. The alternatives will be review for likely impacts.
- *Historic, Architectural, Archaeological, and Cultural Resources:* The adjacent Shaker Historical Site is well documented and has been address by the airport for several projects (including the recent 1,000 space parking garage). These past studies will be reviewed for potential consideration of impacts that may be created by future recommendations.

The results of this effort task will be a generalized review of potential environmental impacts of the recommended airport improvements and to consider the potential extent of future environmental analyses and regulatory issues.

5.7. Airport Noise Evaluation

This task will provide a new airport noise evaluation, including existing and future noise contours based on the activity forecasts. The evaluation will identify if existing and future activity results in noise impacts based on the federal criteria provided in FAA Order 1050.1F, *Environmental Impacts –*

Policies and Procedures, and through the generation of Day-Night Average Noise Level (DNL) noise contours. The evaluation will identify if noise sensitive land uses (e.g., homes, schools, and place of worship) are exposed to noise levels above the federal threshold of impact (DNL 65 dB); however, the increase in DNL (if any) will not be calculate. This task will employ the most recent version of the FAA Aviation Environmental Design Tool (AEDT) for the evaluation.

5.7.1 Prepare Noise Model Inputs

Data input for the existing noise evaluation will use calendar year 2019 annual aircraft operations. The inputs will rely on existing available data, including Air Traffic Control Tower (ATCT) operation counts, FAA T100 data, FAA's Enhanced Traffic Management System Counts (ETMSC), and flight schedules. Operations will be identified by aircraft type for jet aircraft. Types that comprise less than two percent of the total activity may be grouped with a similar aircraft type. For general aviation turboprop and piston aircraft, operations will be categorized as single or twin engine, and input as a composite or representative aircraft.

ACAA will assist with setting up a teleconference with ATCT staff to discuss operational procedures and flight tracks in use at ALB as inputs to the noise model. Items to discuss will include the following, and other items as determined:

- Runway end distribution/percentage for takeoffs and landings
- Typical or estimated nighttime activity (before 7 AM and after 10 PM)
- Approach and departure procedures, and variations by aircraft type/category
- Touch & Go and closed traffic pattern procedures

The future year noise analysis will use the approved 5-year forecast of activity. The future operations will be assembled for a typical (average) day of the year. Operations will be divided into runway ends, aircraft type, day vs. night, operation type (landing, takeoff, touch-&-go, etc.) and input into the AEDT model. Helicopters and special operations can be added to the analysis (but are not currently included).

5.7.2 Noise Modeling

The FAA AEDT will be used to model and generate existing and future noise contours for the Airport, and will generate:

- Existing noise levels based on the current runway layout, airport activity, and operating procedures
- The anticipated future noise levels based on the forecasts, fleet mix, and recommended operational procedures.
- Produce Day-Night Sound Level (DNL) noise contours for the DNL 60, 65, 70, and 75 dBA levels.

The flight tracks identified by ATCT staff will be used to generate input data assignments to the AEDT model. If desired by ACAA or FAA, the scope can be expanded to include an evaluation of recorded historical radar track data available from the Approach Surveillance Radar (ASR) system to determine more detailed flight track use (radar tracks analysis is not currently included in the scope). This task will be conducted exclusively by standard modeling; no noise monitoring activities are included.

2.7.3 Land Use Compatibility

The DNL noise contours will be incorporated into a land use drawing depicting existing noise sensitive land use categories. The drawing scale will be adequate to illustrate the extents of the DNL 60 dBA contour. A combined drawing will be used for current and future noise contours. The noise analysis will identify any impacted areas per federal standards located within the DNL 65, 70, or 75 dBA noise contours, with a focus on the differences between the existing and future noise levels.

The location of noise sensitive land uses will be identified within the 65 DNL. All known noise-sensitive locations and facilities within the contours (e.g., homes, schools, churches, etc.) will be illustrated. A summary of findings will be prepared, including a description and illustrations of the following:

- For existing conditions, the number of homes, or other noise sensitive land uses, within the DNL 65, 70, or 75 dBA contours (if any)
- For forecast conditions, the number of homes, or other noise sensitive land uses, within the DNL 65, 70, or 75 dBA contours (if any)

5.8. Solid Waste and Recycling Plan

The 2012 FAA Reauthorization Act requires airport master plans to address the feasibility of solid waste recycling at airports. This task will review current waste generation and recycling activities and provide a description of best practices that may minimize the volume of solid waste disposal and/or recycling efforts.

The Consultant will discuss existing procedures with local waste and recycling providers for this brief review of the solid waste and recycling stream at the Airport. The waste review will be conducted through informal interviews with local providers, airport management, and vendors. The review will summarize the:

- Amount and types of solid waste generation at the Airport
- Current recycling programs and procedures in place
- Existing waste management contracts

Based on the finding of the review, recommendations for improving solid waste disposal and promoting recycling and waste minimization may be identified.

TASK 6: AERONAUTICAL & NON-AERONAUTICAL DEVELOPMENT EVALUATION

Complementary aeronautical dependent and non-aeronautical land use development can benefit the airport and surrounding community. This task reviews the general shortage and limitation of the airport property, addresses potential property acquisition, and overall development compatibility.

6.1. Property and Land Use Inventory

The existing airport property is rather limited for an airport with the activity of ALB. In several locations, private property existing within a few hundred feet of the airfield. For this task, the Consultant will review existing airport property limits and inventory adjacent parcels generally within 1,000 feet of the airport property line. Items of interest include:

- Ownership (public vs private)
- Land use/compatibility and zoning,
- Size, ground access, and utilities
- Known environmental sensitivity
- Assessed value
- Potential for airfield access

These properties will be listed and illustrated and may be included in the Land Use Plan drawing of the ALP drawing set.

6.2 Demand/Development Potential

This review will classify general land use areas, and the amount of land devoted to each land use category. It will identify existing land use regulations that impact development of the site, such as municipal zoning, overly zoning, and airport development standards. A general determination will be made with respect to what land parcels are the most suitable for immediate and short-term development for potential aviation or non-aeronautical.

An opportunities and constraints map will be created that illustrates where potential new improvements could occur to provide a stream of revenue for the Airport. Complementary non-aeronautical land use development can benefit the airport and surrounding community, in consideration of the recommended long-term airport dependent development, including any property reserved for potential airport needs.

The key to realizing maximum development potential is the assessment of the optimal uses the land will support based on physical, demand, and regulatory considerations. The general evaluation will focus on the airport and support services but may also include other future demand for various land uses (office/hotel/retail/industrial/logistics) in the surrounding area that have been identified by the Town, County, or regional organizations.

This task will include a recommendation for:

- Parcels needed to protect airspace and airport safety requirements
- Property acquisition for existing or future airport facilities
- Property Acquisition for land use compatibility or economic development potential
- Locations for environmental preservation
- Locations/parcels to have limited benefit to the airport

DELIVERABLE: Working Paper No. 3

This working paper will present the findings and recommendations of the development concepts, environmental overview, and the land use analysis.

TASK 7: AIRPORT PLANS

7.1 Recommended Phasing Plan and Costs

The purpose of this subtask will be to develop the phasing plan and cost estimates consistent with the refined development concept. The Consultant Team will evaluate the phasing plan for facilities construction within the 5-year, 10-, and 20-year planning horizons developed for the preferred

airport development concept. A focus will be on the next 10 years, with less details provide for remaining years of the plan.

7.2 Airport Layout Plan

The ALP set will be developed by the Consultant Team following consultation with ACAA staff and the FAA with regard to compliance with FAA AC 150/5070-6B, *Airport Master Plans*. The ALP sheets will be prepared in accordance with the FAA ALP Review Checklist (ARP SOP No. 2.00). However, the Inner Portion of the Approach, Runway Departure Surface, and Airport Airspace Drawing sheets have been completed under previous contract and are not included as part of this scope. The specific ALP sheets to be prepared are listed below. Planimetric mapping collected as part of Task 2.7 will be used to complete the sheets.

7.2.1 Update Title Sheet

The title sheet will include the title of the project, location and vicinity maps, and a sheet index.

7.2.2 Existing Airport Layout Map

The airport-based plan obtained during Task 2.5 will be used to illustrate airport facilities as they exist currently.

7.2.3 Airport Layout Plan

The ALP will be updated in accordance with the previously referenced FAA Advisory Circulars and will depict existing and future airport development projects in schematic form on a large-scale plan at 1" = 600'. The ALP will include basic information such as topographic detail, runway data, RPZ data, safety areas, property lines, and the Airport reference point. The ALPs will also include approval blocks and title and revision blocks.

7.2.4 Airport Data Sheet

The data sheet will include wind roses, wind coverage tables, Airport data tables, and runway data tables. Standardized templates for each table are provided in the FAA ALP Review Checklist.

7.2.5 Terminal Area Plan

A terminal area plan will be updated in accordance with the previously-referenced FAA Advisory Circulars. Terminal area plans will be developed for the proposed passenger terminal complex recommended for ALB. Details not depicted on the ALP will be depicted on the larger scale terminal area plans at a likely scale of 1" = 200'. The plan will include existing and future building data tables, known elevations of structures, passenger terminal building and parking details, and a legend.

7.2.6 Land Use Plan

This plan will be prepared in accordance with the previously referenced FAA Advisory Circulars. The land uses will be depicted by general use categories. This plan will be a key study product, since it will identify existing and recommended uses for all areas under Airport control, as well as surrounding areas within the Runway Protection Zones (RPZ) and DNL 65 noise contour (to be provided by ACAA).

7.2.7 Airport Property Map Preparation

This subtask will use available information provided by the ACAA (in AutoCAD) for updating the Property Map. The key purpose of this drawing is to identify the airport property boundary and history of parcel acquisition, including use of federal grants.

FAA ARP SOP No. 3.00 for FAA Exhibit 'A' Airport Property Inventory Maps will be used to determine any shortfalls in the property data. This task will add the available Exhibit A data to new airport mapping. No research, site surveys, searches of titles, deeds, or property history is included in this work effort. Any work effort needed to update, and supplement information provided by ACAA is considered extra work and out-of-scope.

Other ALP Sheets - including the airspace/inner approach surface drawings. A separate Airport AGIS and Obstruction Study contract is being completed for ACAA. That effort will include a drawing set that contains the Inner Approach Surface Plan and Profile Drawings, Airspace Drawing, and associated Obstruction Data Table Sheets. This drawing set is being delivered separately from the master plan and will not be duplicated. CHA can add those drawings (provided by others) to the ALP drawing set for consistency and submission to FAA and will provide a CADD template for use.

DELIVERABLE: ALP Drawing Set

The ALP drawings will consist of a set of formal plan sheet for review by ACAA, the Advisory Committees, and FAA. A formal draft will be provided for review and comment. The final ALP drawings are presented at the end of the study for FAA approval

TASK 8: FINANCIAL PLAN [Task Removed]

~~In consultation with the ACAA, the Consultant Team will develop estimates of net revenues available to pay debt service while maintaining ALB's financial ratios within those of comparable airports. When combined with estimates of local funds, passenger facility charges (PFCs), customer facility charges (CFCs), available Airport Improvement Program (AIP) grants, state grants, financing costs and interest rates, expected construction schedules, and inflation, a range for a project budget is established.~~

~~While the resulting project budget range is not intended to dictate the size of the CIP, it is meant to provide a guideline to develop a CIP within certain financial parameters that make it affordable to the ACAA. Any of the assumptions included in this analysis can be altered, which may increase or decrease the project budget. For example, if ALB believes it will receive more grants than assumed, the project budget will increase. The same is true with the accuracy of the activity, revenue, and expense forecasts. All of the metrics can be adjusted to determine the effect on the project budget. The financing capacity would include the following elements:~~

- ~~• Benchmarking analysis to provide perspective on the financial picture at ALB by comparing its financial metrics to its peers. This comparison will be developed with information included in the Federal Aviation Administration's (FAA) Certification Activity Tracking System data base for the most recent year for which data was available.~~
- ~~• Activity forecasts will be incorporated into the financing capacity.~~
- ~~• Airline revenues will be determined on a cost per enplanement basis.~~
- ~~• Operating expense and non-airline revenue projections will be developed.~~
- ~~• Operating expenses will be deducted from airline and non-airline revenues to determine net revenues available for debt service. Outstanding debt service will be deducted from this amount to determine net revenues available for future debt service.~~
- ~~• Potential funding sources of the CIP will be identified (i.e., AIP entitlement and discretionary funding, state funding, PFCs, CFCs, and ALB funds).~~
- ~~• Finally, the amount available for project costs is determined.~~

- This base case will be used as a benchmark from which scenarios will be prepared.

A summary report will be prepared documenting findings and baseline information to be utilized for preparation of the Financial Plan.

8.1 Financial Assumptions

The financial plan of the Master Plan presents the financial assumptions which will ultimately impact facility and funding requirements. Initial assumptions and project objectives are revised to reflect changes in activity forecasts and collateral development alternatives. Elements to be refined include the types of facilities to be built or rehabilitated, the total costs of these facilities, the timing of cash flows associated with the construction of planned facilities, and financing sources and terms. As part of this process, the Consultant Team will identify the specific financial data and information necessary to provide adequate financial evaluations of any proposed development resulting from the planning process. This information will pertain primarily to the following, as it is available:

- Historical activity data
- Comprehensive Annual Financial Reports for two years
- Rates and charges packages for the past year
- Operating budget for the most recent year
- Airline agreement
- Tenant agreements
- Bond resolution
- Outstanding debt service schedules
- Federal grant applications and approvals
- PFC applications
- CFC agreement
- Other pertinent data required to complete a financial feasibility unique to the airport

The estimated demand on operating revenues and the impact on tenant rates and charges will be identified and analyzed and recommended strategies for completing and funding the proposed projects will be presented. The preferred alternative will reflect a financial management structure in combination with a physical plan which accomplish ALB's objectives for strategic growth, economic development, air and ground transportation services, and environmental mitigation.

8.2 Sources & Uses of Funds Analysis

Review design cost and phasing to determine both the costs and the different sources of funding for the recommendations including any portion that must be financed through bonds.

8.3 Revenue Forecast Analysis

Project amount and timing of additional revenues from increased facilities and from activity forecasts, as well as reviewing concession tenant leases to determine if rates can be increased during the projection period.

8.4 Operating Expense Projections

Analyze historical trends and the impact of new facilities on projections.

8.5 Cash Flow Analysis

Calculate net revenue projections and project internal rates of return, net present values, and the effects of economic and financial constraints on project viability.

8.6 Debt Service Analysis

Determine the par amounts required for construction and or refinancing; calculation of required reserve funds, capitalized interest, and debt service coverage per the bond resolution.

DELIVERABLE: Working Paper No. 4

This final working paper will present the cost of the recommended plan (i.e., the long term Airport Capital Improvement Plan) and the Financial Plan. The ACAA may choose to release this working paper to Advisory Committees or provide the chapter in the overall Master Plan technical report (See Task 9 below).

TASK 9: DOCUMENTATION

9.1 Master Plan Technical Report

9.1.1 Revisions to Master Plan Working Papers

The results of the above tasks will be documented in separate working papers to serve as the primary data reference for the Study. All working papers, which will include narratives and supporting tables, charts, and other appropriate graphic materials, throughout the development of the Master Plan Update will be combined in to the “pre-draft” master plan report and distributed to ACAA and FAA for review and comments. Comments received will be incorporated and include in the formal “Draft” Airport Master Plan Update report.

9.1.2 Draft Master Plan Technical Report

The purpose of this task will be to provide the ACAA, FAA, airport committee, and general public with the opportunity review and comment on the study findings prior to publication of the final report. The Draft Report will be published for public review on the study website. Emails will be sent to all committee members (see Task 12) with notice of the availability of the draft report, as well as to persons on the study mailing list.

Ten (10) copies of a draft Master Plan Update technical report, including color exhibits where appropriate, will be prepared and submitted for ACAA and FAA review. The draft report will be amended as necessary based on this review and the comments provided.

9.1.3 Publish Final Master Plan Technical Report

The Final Master Plan Update technical report will be published in an electronic format, on the study website, and up to twenty (20) hard copies will be provided to ACAA.

9.2 Executive Summary

An executive summary of the Master Plan Update will be prepared for placement at the front of the final Master Plan Update technical report. The text will be formatted to allow for separate reproduction and distribution. It will include an overview of the analysis and findings, and a description of the recommendations. Graphics and maps will be provided to facilitate understanding by a wide range of potential readers. Up to 200 copies of the Executive Summary will be printed, with an electronic copy (in PDF) will be published on the study website.

TASK 10: STAKEHOLDER & COMMUNITY OUTREACH

The Stakeholder and Community Outreach program will commence at the initiation of the master plan and extend through the formal FAA approval of the Airport Layout Plan. This program will consist of public meetings, technical and regional advisory committee meetings, periodic briefings to the ACAA board, as well as a study website to post study related information.

As listed in the subtasks below the general schedule of meetings is outlined as follows, but subject to change at the direction of the ACAA. In all, 11 formal meetings are planned during the course of the study effort.

Timeframe for Study Meetings				
Meeting Type	Working Paper 1	Working Paper 2	Working Paper 3	Draft Report
Public Meetings	X	X		X
Technical Advisory Committee (TAC)	X	X	X	X
Regional Advisory Committee (RAC)	X	X	X	X

10.1 Study Website

The Consultant will design, develop, and host a custom website suited to the subject matter of the study. The website will be located on a separate registered domain with a name such as: www.ALB-master-plan.com

This website will provide narrative and graphical information and will be maintained and updated up to ten times throughout the study duration. The goal of the website is to provide a readily accessible, convenient location where the public can access project specific information, such as project public meeting announcements, meeting agendas, and minutes, contact information, working papers, and draft and final master plan reports. The website will also contain links to the Albany airport website, and others with pertinent information to the project.

Contact information for the Sponsor and an email address for submitting comments will also be included. The Consultant will assist the Sponsor with responses to email questions and comments. All email comments will be saved; however, responses to all comments are not anticipated.

Website visitor will have the option to sign-up for email notifications for new posted information. Persons signing up for announcements will be informed of the date, time, and location of each of the public meetings, as well as once a study report is uploaded for public review.

To assist with day-to-day collaboration between ACAA, FAA, and Consultant Team members, a password protected cloud-based file storage system will be included as part of the web services. This tool will operate as a traditional cloud based storage system site such as Microsoft SharePoint, providing defined folders to organize and centralize project data. The cloud-based storage system avoids limitations on file size transfers via email and provides for permanent storage and accessibility pre-draft documents by Airport staff.

10.2 Public Meetings/Workshops

Three public information meetings/workshops will be held following the release of working papers 1 and 2, and the draft master plan report. These meetings will be designed to inform the general public of study progress and findings as the study advances. It will also provide the opportunity for public comment on the program. The public meetings/workshops may be structured as traditional or "open house / workshop" type gatherings. The intent is to involve both the local community affected by Airport development and the larger regional community concerned with air service and economic development issues. Public meeting activities will include:

- Issue meeting notices to the news media, web postings, and email notifications
- Prepare presentation materials and handouts
- Attend and present at the meetings (3 Consultant Team members)
- Prepare comment forms, collect comments.
- Prepare meeting summaries and responses to key comments
- Posting of material on study website

Meetings will be held in the early evening in a location determined by ACAA that is large enough to accommodate the anticipated attendance. The public meetings may utilize a facility provided by the Town of Colonie, Albany County, or a local school. Alternatively, hotel conference space may be utilized, but will require a project eligible fee.

10.3 Technical Advisory Committee Meetings

A study technical advisory committee (TAC) will be formed to provide guidance and advice on technical issues to the ACAA and to the Consultant team. It will consist of representatives of ACAA, as well as airport users and operators including:

- Airport Operations/management
- Airlines and air cargo operators
- Other airport tenants (FBO's &
- Service vendors (rental car, parking, concessions)
- Corporate tenants (FBO, Business Aviation)
- ATCT staff
- Public Safety: TSA, Sheriff, NYS Police
- FAA & NYSDOT

The TAC will meet four (4) times during the course of the work program and include up to approximately 20 members. It is anticipated that the TAC meetings will be held as part of coordinated series of meetings at key decision points in the study process.

For each meeting 2 to 3 members of the Consultant Team will attend and will vary depending on the subject matter of the meeting (attendance may be virtual as needed). For each meeting, the Consultant will prepare and distribute a meeting announcement (via email), an agenda, presentation and/or handouts, and prepare the meeting notes for review and approval by ACAA. It is assumed that each meeting will be held in the main terminal conference room (terminal building 3rd floor) during regular business hours.

Consultant Team activities will include:

- Invitation letters via email/phone calls, as needed

- Preparation of presentation materials and briefing papers
- Attendance/presentations at meetings
- Meeting summaries
- Posting of materials on study website

10.4 Regional Advisory Committee Meetings

A separate regional advisory committee (RAC) will be formed to provide insight and information on non-technical issues that are pertinent to a broader community perspective. The RAC may also include up to approximately 20 members. The consultant team and the Authority will work together on identifying members of the RAC. Typically, the RAC will include representation from regional planning agencies, economic development organizations, and transportation planning groups, business-related organizations, and elected official (or their appointee). The RAC will meet four (4) times during the work program. These meetings will be programmed to occur after the TAC meetings, either on the same day or on the following day. It is anticipated that the RAC meetings will be held as part of coordinated series of meetings at key decision points in the study process. Potential membership may include:

- Albany County
 - Department of Public Works
 - Department of Economic Development, Conservation & Planning
- Town of Colonie
 - Department of Planning & Economic Development
 - Department of Public Works
- Capital District Regional Planning Commission (CDRPC)
- Capital District Transportation Authority (CDTA)
- Capital District Transportation Committee (CDTC)
- Capital Region Chamber
- Shaker Heritage Society of Albany
- NYS Senator and Assembly Representatives
- Municipal representatives (Albany County, City of Albany, & Town of Colonie)

Consultant Team activities will include:

- Invitation letters, via email/phone calls, as needed
- Preparation of presentation materials and briefing papers
- Attendance/Presentations at meetings
- Meeting summaries
- Posting of materials on study website

10.5 Briefings for the ACAA Board

During the Study, it is anticipated that the need will occur to brief the Airport Authority on areas of special concern or interest to them, ahead of broader public discussions and announcements. The program will include three (3) of these board briefings. This task covers preparation for and attendance at these briefings.

Fee proposal:

- CHA Consulting, Inc. \$424,052.68
- Jacobsen and Daniels \$120,046.79
- Gensler \$205,865.79

Total: \$749,965.26

FEE SUMMARY					
Task Title: Airport Master Plan/Airport Layout Plan Updates					
Albany International Airport (ALB)					
	CHA	JD	GENSLER	DKMG	Total
Tasks					
Task 1: STUDY DESIGN AND SCOPING					
1.1: Project Definition and Scoping	48				48
1.2: Kickoff Meeting & Working Schedule	40				40
1.3: Project Administration	216				216
Task 1 Subtotal	304				304
Task 2: AIRPORT INVENTORY					
2.1: Inventory of Airport Facilities	40		26		66
2.2: Inventory of Operations, Airspace, and Air Traffic Control Procedures	40				40
2.3: Interviews of Stakeholders	52	20	24		96
2.4: Socio-Economic Data		20			20
2.5: Inventory of Existing Parking Facilities		20			20
2.6: Passenger Ground Access		36			36
2.7: Development of Airport Layout Plan Base Map	60				60
Task 2 Subtotal	192	96	50		338
Task 3: FORECASTS OF AVIATION DEMAND					
3.1: Aviation Forecasts		56			56
3.2: FAA & State Coordination	32	12			44
3.3: Develop Future Design Day Flight Schedule		88			88
Task 3 Subtotal	32	156			188
Deliverable: Working Paper No.1					
	80				80
Task 4: DEMAND/CAPACITY ANALYSIS AND FACILITY REQUIREMENTS					
4.1: Determine Airfield Requirements	168				168
4.2: Passenger Terminal Facility	128	94	376		598
4.3: Determine Airport Parking & Curbside Requirements	20	40			60
4.4: Evaluate Air Cargo Facility Requirements	78	32			110
4.5: Determine Corporate/FBO/General Aviation Requirements		50			50
4.6: Develop Support Facility/Demand Capacity Analysis & Future Requirements		32			32
Task 4 Subtotal	394	248	376		1018
Deliverable: Working Paper No.2					
	80				80

FEE SUMMARY					
Task Title: Airport Master Plan/Airport Layout Plan Updates Albany International Airport (ALB)					
	CHA	JD	GENSLER	DKMG	Total
Tasks					
Task 5: AIRPORT DEVELOPMENT CONCEPTS					
5.1: Airfield Improvement Concepts	148				148
5.2: Passenger Terminal Facility Concepts	48		606		654
5.3: Access & Parking Concepts	56	232			288
5.4: General Aviation, Air Cargo, and Support Facility Concepts	192				192
5.5: Final Concept Development	80				80
5.6: Environmental Overview	64				64
5.7: Airport Noise Evaluation	88				88
5.8: Solid Waste and Recycling Plan	48				48
Task 5 Subtotal	724	232	606		1562
Task 6: Non-Aeronautical Development Evaluation					
6.1: Property and Land Use Review	40				40
6.2: Demand/Development Potential	100				100
Task 6 Subtotal	140				140
Deliverable: Working Paper No.3	80				80
Task 7: AIRPORT PLANS					
7.1: Recommended Phasing Plan and Costs	88				88
7.2: Airport Layout Plan	372				372
Task 7 Subtotal	460				460

FEE SUMMARY					
Task Title: Airport Master Plan/Airport Layout Plan Updates Albany International Airport (ALB)					
	CHA	JD	GENSLER	DKMG	Total
Tasks					
Task 8: FINANCIAL PLAN (Removed by ALB)					
8.1: Financial Assumptions					
8.2: Sources & Uses of Funds Analysis					
8.3: Revenue Forecast Analysis					
8.4: Operating Expense Projections					
8.5: Cash Flow Analysis					
8.6: Debt Service Analysis					
Task 8 Subtotal					
Deliverable: Working Paper No.4					
Task 9: DOCUMENTATION					
9.1: Master Plan Technical Report	72				72
9.2: Executive Summary Report	48				48
Task 9 Subtotal	120				120
Task 10: STAKEHOLDER & COMMUNITY OUTREACH					
10.1: Study Website	184				184
10.2: Public Meetings/Workshops	156	14	26		196
10.3: Technical Advisory Committee Meetings	148		14		162
10.4: Regional Advisory Committee Meetings	148		6		154
10.5: Briefings for the ACAA Board	4				4
Task 10 Subtotal	640	14	46		700
Task 11: OPTIONAL INTERACTIVE PLANNING TOOLS (AIP Eligible) - not included					
11.1: GIS Planning Tool					
11.2: Capital Program Development and Visualization					
Task 11 Subtotal					
TOTAL Hours	3006	746	1078		4830
TOTAL Costs	\$ 152,193	\$ 42,502	\$ 55,680	\$ -	\$ 250,375.24
Total Labor, Overhead & Profit	\$ 420,052.68	\$ 114,666.79	\$ 203,685.79	\$ -	\$ 738,405.27
Expenses	\$ 4,000.00	\$ 5,380.00	\$ 2,180.00	\$ -	\$ 11,560.00
Grand Total	\$ 424,052.68	\$ 120,046.79	\$ 205,865.79	\$ -	\$ 749,965.27

CHA Consulting, Inc.									
Task Title: Airport Master Plan/Airport Layout Plan Updates									
Albany International Airport (ALB)									
	Principal In Charge	Project Manager/Senior Principal Planner	Principal Planner/Engineer	Senior Planner/Engineer	Project Planner/Engineer	Planner/Engineer	CADD/Designer Tech	Project Tech	Total
Hourly Rate (Direct Labor)	\$90.00	\$75.00	\$61.50	\$53.25	\$44.00	\$35.50	\$34.00	\$26.50	
Tasks									
Task 1: STUDY DESIGN AND SCOPING									
1.1: Project Definition and Scoping	8	32	8						48
1.2: Kickoff Meeting & Working Schedule		20	20						40
1.3: Project Administration		120	48					48	216
Task 1 Subtotal	8	172	76	0	0	0	0	48	304
Task 2: AIRPORT INVENTORY									
2.1: Inventory of Airport Facilities		4	4	24	8				40
2.2: Inventory of Operations, Airspace, and Air Traffic Control Procedures		8	8	8	16				40
2.3: Interviews of Stakeholders		24	8		20				52
2.4: Socio-Economic Data									0
2.5: Inventory of Existing Parking Facilities									0
2.6: Passenger Ground Access									0
2.7: Development of Airport Layout Plan Base Map		8	4	8	30		10		60
Task 2 Subtotal	0	44	24	40	74	0	10	0	192
Task 3: FORECASTS OF AVIATION DEMAND									
3.1: Aviation Forecasts									0
3.2: FAA & State Coordination		16		16					32
3.3: Develop Future Design Day Flight Schedule									0
Task 3 Subtotal	0	16	0	16	0	0	0	0	32
Deliverable: Working Paper No.1		8	4	8		40	20		80
Task 4: DEMAND/CAPACITY ANALYSIS AND FACILITY REQUIREMENTS									
4.1: Determine Airfield Requirements		24	8	36	60		40		168
4.2: Passenger Terminal Facility		16	16	40	40	16			128
4.3: Determine Airport Parking & Curbside Requirements		4		8	8				20
4.4: Evaluate Air Cargo Facility Requirements		2		4	16	40	16		78
4.5: Determine Corporate/FBO/General Aviation Requirements									0
4.6: Develop Support Facility/Demand Capacity Analysis & Future Requirements									0
Task 4 Subtotal	0	46	24	88	124	56	56	0	394
Deliverable: Working Paper No.2		8	4	8		40	20		80
Task 5: AIRPORT DEVELOPMENT CONCEPTS									
5.1: Airfield Improvement Concepts		16	8	24	80		20		148
5.2: Passenger Terminal Facility Concepts		16	8	24					48
5.3: Access & Parking Concepts		16	8	32					56
5.4: General Aviation, Air Cargo, and Support Facility Concepts		24	8	24	80	16	40		192
5.5: Final Concept Development		8	4	16	8	32	12		80
5.6: Environmental Overview				8	16	40			64
5.7: Airport Noise Evaluation		4		8	8	60	8		88
5.8: Solid Waste and Recycling Plan				8	40				48
Task 5 Subtotal	0	84	36	144	232	148	80	0	724

CHA Consulting, Inc.									
Task Title: Airport Master Plan/Airport Layout Plan Updates									
Albany International Airport (ALB)									
	Principal in Charge	Project Manager/Senior Principal Planner	Principal Planner/Engineer	Senior Planner/Engineer	Project Planner/Engineer	Planner/Engineer	CADD/Designer Tech	Project Tech	Total
Hourly Rate (Direct Labor)	\$90.00	\$75.00	\$61.50	\$53.25	\$44.00	\$35.50	\$34.00	\$26.50	
Tasks									
Task 6: Non-Aeronautical Development Evaluation									
6.1: Property and Land Use Review		4		8		20	8		40
6.2: Demand/Development Potential	4	8	4	16		60	8		100
Task 6 Subtotal	4	12	4	24	0	80	16	0	140
Deliverable: Working Paper No.3		8	4	8		40	20		80
Task 7: AIRPORT PLANS									
7.1: Recommended Phasing Plan and Costs		8	16	24		40			88
7.2: Airport Layout Plan		8	4	40	160	40	120		372
Task 7 Subtotal	0	16	20	64	160	80	120	0	460
Task 8: FINANCIAL PLAN									
8.1: Financial Assumptions									0
8.2: Sources & Uses of Funds Analysis									0
8.3: Revenue Forecast Analysis									0
8.4: Operating Expense Projections									0
8.5: Cash Flow Analysis									0
8.6: Debt Service Analysis									0
Task 8 Subtotal	0	0	0	0	0	0	0	0	0
Deliverable: Working Paper No.4									0
Task 9: DOCUMENTATION									
9.1: Master Plan Technical Report		8		8		40	16		72
9.2: Executive Summary Report		8		8		24	8		48
Task 9 Subtotal	0	16	0	16	0	64	24	0	120

CHA Consulting, Inc.
 Task Title: Airport Master Plan/Airport Layout Plan Updates
 Albany International Airport (ALB)

	Principal In Charge	Project Manager/Senior Principal Planner	Principal Planner/Engineer	Senior Planner/Engineer	Project Planner/Engineer	Planner/Engineer	CADD/Designer Tech	Project Tech	Total
Hourly Rate (Direct Labor)	\$90.00	\$75.00	\$61.50	\$53.25	\$44.00	\$35.50	\$34.00	\$26.50	
Tasks									
Task 10: STAKEHOLDER & COMMUNITY OUTREACH									
10.1: Study Website		12	8	4	80	80			184
10.2: Public Meetings/Workshops	16	48	40		24	12	16		156
10.3: Technical Advisory Committee Meetings	16	40	40		24	12	16		148
10.4: Regional Advisory Committee Meetings	16	40	40		24	12	16		148
10.5: Briefings for the ACAA Board		4							4
Task 10 Subtotal	48	144	128	4	152	116	48	0	640
Task 11: OPTIONAL INTERACTIVE PLANNING TOOLS (AIP Eligible)									
11.1: GIS Planning Tool									0
11.2: Capital Program Development and Visualization									0
Task 11 Subtotal	0	0	0	0	0	0	0	0	0
TOTAL Hours	60	550	312	396	742	544	354	48	3006
TOTAL Costs	\$ 5,400	\$ 41,250	\$ 19,188	\$ 21,087	\$ 32,648	\$ 19,312	\$ 12,036	\$ 1,272	\$ 152,193.00

Expenses	
1. Travel (mileage, airfare, rental car, etc.)	\$ -
2. Lodging	\$ -
3. Meals/Per Diem	\$ -
4. Reproductions and Report Preparation	\$ 3,000.00
5. Meeting Room Rental & Associated Costs	\$ -
6. Special Meeting Materials (e.g., boards, posters, etc.)	\$ 1,000.00
7. Mailing Expenses	\$ -
8. Newspaper Advertisements/Misc	\$ -
9. Commercial Mailing Lists/Databases	\$ -
10. Database Acquisition	\$ -
TOTAL EXPENSES	\$ 4,000.00

Total Firm Costs	
TOTAL DIRECT LABOR COST	\$ 152,193.00
OVERHEAD @ 140%	\$ 213,070.20
TOTAL LABOR COST	\$ 365,263.20
FEE @ 15%	\$ 54,789.48
SUBTOTAL	\$ 420,052.68
TOTAL EXPENSES	\$ 4,000.00
TOTAL COSTS	\$ 424,052.68

Jacobson & Daniels								
Task Title: Airport Master Plan/Airport Layout Plan Updates								
Albany International Airport (ALB)								
	Senior Vice President	Director	Project Manager	Senior Consultant	Consultant	Analyst	Project Assistant	Total
Hourly Rate (Direct Labor)	\$106.01	\$74.28	\$68.15	\$41.83	\$36.54	\$31.50	\$22.00	
Tasks								
Task 2: AIRPORT INVENTORY								
2.3: Interviews of Stakeholders		4	16		0			20
2.4: Socio-Economic Data		12	8		0			20
2.5: Inventory of Existing Parking Facilities			16		4	0		20
2.6: Passenger Ground Access			32		4	0		36
Task 2 Subtotal	0	16	72	0	8	0	0	96
Task 3: FORECASTS OF AVIATION DEMAND								
3.1: Aviation Forecasts	0	20	32	0	4	0		56
3.2: FAA & State Coordination	4	4	4					12
3.3: Develop Future Design Day Flight Schedule	0	24	48	4	12			88
Task 3 Subtotal	4	48	84	4	16	0	0	156
Task 4: DEMAND/CAPACITY ANALYSIS AND FACILITY REQUIREMENTS								
4.2.1: Terminal Gate Requirements		8	40	32		10	4	94
4.3: Determine Airport Parking & Curbside Requirements		8	24	4	4			40
4.4: Evaluate Air Cargo Facility Requirements		8	8	8	8			32
4.5: Determine Corporate/FBO/General Aviation Requirements		8	0	24	18			50
4.6: Develop Support Facility/Demand Capacity Analysis & Future Requirements		8	8	8	8			32
Task 4 Subtotal	0	40	80	76	38	10	4	248
Task 5: AIRPORT DEVELOPMENT CONCEPTS								
5.3: Access & Parking Concepts	2	8	60	30	48	60	24	232
Task 5 Subtotal	2	8	60	30	48	60	24	232
Task 10: STAKEHOLDER & COMMUNITY OUTREACH								
10.2: Public Meetings/Workshops	0	2	12		0	0		14
10.3: Technical Advisory Committee Meetings	0	2	12		0	0		14
10.4: Regional Advisory Committee Meetings	0	0	0		0	0		0
Task 10 Subtotal	0	4	24	0	0	0	0	28

Jacobson & Daniels									
Task Title: Airport Master Plan/Airport Layout Plan Updates									
Albany International Airport (ALB)									
	Senior Vice President	Director	Project Manager	Senior Consultant	Consultant	Analyst	Project Assistant	Total	
Hourly Rate (Direct Labor)	\$106.01	\$74.28	\$68.15	\$41.83	\$36.54	\$31.50	\$22.00		
Tasks									
Task 11: OPTIONAL INTERACTIVE PLANNING TOOLS (Non AIP Eligible)									
11.1: GIS Planning Tool								0	
11.2: Capital Program Development and Visualization								0	
Task 11 Subtotal	0	0	0	0	0	0	0	0	
TOTAL Hours	6	116	320	110	110	70	28	760	
TOTAL Direct Costs	\$ 636	\$ 8,616	\$ 21,808	\$ 4,601	\$ 4,019	\$ 2,205	\$ 616	\$ 42,502	
Expenses				Total Firm Costs					
1. Travel (mileage, airfare, rental car, etc.)	\$ 1,200.00							TOTAL DIRECT LABOR COST	\$ 42,502.24
2. Lodging	\$ 280.00			134.6%				OVERHEAD @	\$ 57,208.02
3. Meals/Per Diem	\$ 400.00							TOTAL LABOR COST	\$ 99,710.26
4. Reproductions and Report Preparation	\$ 500.00			15%				FEE @	\$ 14,956.54
OGS Flight Schedule / Woods and Poole data	\$ 3,000.00							SUBTOTAL	\$ 114,666.79
6. GIS licensing costs (\$100 per year per read license)								TOTAL EXPENSES	\$ 5,380.00
TOTAL EXPENSES	\$ 5,380.00							TOTAL COSTS	\$ 120,046.79

CHA Consulting, Inc.
 Task Title: Airport Master Plan/Airport Layout Plan Updates
 Albany International Airport (ALB)

	Principal in Charge	Quality Assurance Reviewer	Project Manager	Senior Programmer / Lead Designer	Programmer / Planner	Administrator	Architect	Technical Designer	Total
Hourly Rate	\$97.50	\$75.00	\$67.50	\$60.00	\$48.00	\$45.00	\$36.00	\$30.00	
Tasks									
Task 2: AIRPORT INVENTORY									
2.1.2: Inventory of Passenger Terminal Facilities	0	0	1	0	0	1	16	8	26
2.3: Interviews of Stakeholders	0	0	1	20	0	1	2	0	24
Task 2 Subtotal	0	0	2	20	0	2	18	8	50
Task 4: DEMAND/CAPACITY ANALYSIS AND FACILITY REQUIREMENTS									
4.2: Passenger Terminal Facility	4	8	42	160	100	8	20	34	376
Task 4 Subtotal	4	8	42	160	100	8	20	34	376
Task 5: AIRPORT DEVELOPMENT CONCEPTS									
5.2: Passenger Terminal Facility Concepts	4	16	52	200	162	12	104	56	606
Task 5 Subtotal	4	16	52	200	162	12	104	56	606
Task 10: STAKEHOLDER & COMMUNITY OUTREACH									
10.2: Public Meetings/Workshops	0	0	0	8	0	2	12	4	26
10.3: Technical Advisory Committee Meetings	0	0	0	12	0	0	0	2	14
10.4: Regional Advisory Committee Meetings	0	0	0	4	0	0	0	2	6
Task 10 Subtotal	0	0	0	24	0	2	12	8	46
TOTAL Hours	8	24	96	404	262	24	154	106	1,078
TOTAL Costs	\$ 780	\$ 1,800	\$ 6,480	\$ 24,240	\$ 12,576	\$ 1,080	\$ 5,544	\$ 3,180	\$ 55,680.00

Expenses	
1. Travel (mileage, airfare, rental car, etc.)	\$ 1,600.00
2. Lodging	\$ 200.00
3. Meals/Per Diem	\$ 380.00
4. Reproductions and Report Preparation	\$ -
5. Special Meeting Materials (e.g., boards, posters, etc.)	\$ -
6. Mailing Expenses	\$ -
TOTAL EXPENSES	\$ 2,160.00

Total Firm Costs	
TOTAL DIRECT LABOR COST	\$ 55,680.00
OVERHEAD @ 218%	\$ 121,438.08
TOTAL LABOR COST	\$ 177,118.08
FEE @ 15%	\$ 26,567.71
SUBTOTAL	\$203,685.79
TOTAL EXPENSES	\$ 2,160.00
TOTAL COSTS	\$205,865.79

DKMG				
Task Title: Airport Master Plan/Airport Layout Plan Updates				
Albany International Airport (ALB)				
	Principal (Lead)	Principal		
Hourly Rate (Includes Overhead & Profit)	\$275.00	\$275.00		Total
Tasks				
Task 8: FINANCIAL PLAN				
8.1: Financial Assumptions	0	0		0
8.2: Sources & Uses of Funds Analysis	0	0		0
8.3: Revenue Forecast Analysis	0	0		0
8.4: Operating Expense Projections	0	0		0
8.5: Cash Flow Analysis	0	0		0
8.6: Debt Service Analysis	0	0		0
Task 8 Subtotal	0	0	0	0
Task 10: STAKEHOLDER & COMMUNITY OUTREACH				
10.3: Technical Advisory Committee Meetings	0	0		0
10.4: Regional Advisory Committee Meetings	0	0		0
Task 10 Subtotal	0	0	0	0
TOTAL Hours	0	0	0	0
TOTAL Costs	\$ -	\$ -	\$ -	\$ -



William C. Hennessy, Jr. P.E.

June 1, 2020

Stephen Iachetta, AICP
Albany International Airport
Administration Building
Albany, NY 12211

Re: IFE – S1042 Master Plan

Dear Mr. Iachetta:

You recently requested I provide an Independent Fee Estimate (IFE) for Contract S1042 - *Airport Master Plan*. Nan Stolzenburg, AICP, CEP from Community Planning and Environmental Associates assisted on this work. This review considered:

- FAA Advisory Circular 150/5100-14E: ARCHITECTURAL, ENGINEERING, AND PLANNING CONSULTANT SERVICES FOR AIRPORT GRANT PROJECTS,
- FAA Advisory Circular 150/5070-6B: AIRPORT MASTER PLANS,
- and our past experience in similar work.

FAA Advisory Circular 150/5100-14E suggests utilizing the ASCE Handbook 45, which includes estimated guidelines for design fees and total fees received versus construction costs. This is not pertinent to the Airport Master Plans. The FAA Circular also suggests using hourly estimates and past experience in similar work.

Total hours for each task were estimated and an *estimated* hourly rate for specific labor categories were assigned. These rates are only estimates and vary greatly between consultants. They are dependent on individual labor rates and overhead. It is, however, arguable that a higher salaried employee in the same job classification may complete the task in less hours than a lower salaried employee due to experience and ability. Thus resulting in a similar overall comparable fee.

FAA Airport Master Plan Circular 150/5070-6B suggests categories for the Plan. Due to the preliminary nature of these categories we prepared only a rough estimate for the Plan. This estimate per the attached spreadsheet was approximately \$641,000.

A more specific estimate was prepared based on the scope of services delivered by the consultant. This estimate per the attached spreadsheet was approximately \$786,000.

Therefore based on this information, the above described methods and complexity of work, this fee estimate \$780,000.

Sincerely,

A handwritten signature in black ink, appearing to read "W. Hennessy, Jr.", written in a cursive style.

William C. Hennessy, Jr. P.E.

AGENDA ITEM NO. 11

Authorization of Change Orders

AGENDA ITEM NO. 11.1

Change Order #7: Authorization to award Change Orders #7 to Contract # 989-GCr New Parking Garage (Gateway Sign) General Construction to LeChase Construction Services, LLC.

AGENDA ITEM NO: 11.1
MEETING DATE: June 8, 2020

111,173.35ALBANY COUNTY AIRPORT AUTHORITY
REQUEST FOR AUTHORIZATION

ACAA Approved
06/08/2020

DEPARTMENT:

Contact Person: *John LaClair, P.E. Airport Engineer*

PURPOSE OF REQUEST:

Change Order #7: *Authorization to award Change Order #7 to Contract # 989-SF
New Parking Garage Site and Foundations to LeChase
Construction Services, LLC.*

CONTRACT AMOUNT:

Base Amount:	\$8,821,000.00
Change Order #1:	197,569.82
Change Order #2:	169,837.05
Change Order #3:	47,561.92
Change Order #4:	180,434.30
Change Order #5:	111,173.35
Change Order #6:	24,246.60
Change Order #7:	<u>(162,000.00)*</u>
Total:	\$9,389,823.04

**Pending approval at this meeting.*

BUDGET INFORMATION:

Federal Airport Improvement Program
Anticipated in Current ALB Capital Plan : Yes J No ___ NA
Funding Account No.: CPN 2261

FISCAL IMPACT – FUNDING

Federal 2.0% State 35.4% Airport 62.6% NA _____
Term of Funding: 2018-2020
Grant No.: N/A State PIN: 1A00.97

JUSTIFICATION:

Request for authorization of Change Order #7 for Contract 989-SF for New Parking Garage Site and Foundations, to LeChase Construction Services LLC of Schenectady, N.Y. in the amount of -\$162,000.00. This item is a credit for the depressurization well which was never completed by the contractor in accordance with the plans and specifications.

AGENDA ITEM NO: 11.1
MEETING DATE: June 8, 2020

CHIEF EXECUTIVE OFFICER'S RECOMMENDATION:

Recommend approval.

FINAL AGREEMENT SUBJECT TO APPROVAL BY COUNSEL: YES NA

PROCUREMENT DEPARTMENT APPROVAL:

Procurement complies with Authority Procurement Guidelines and Chief Financial Officer has approved. YES NO .

BACK-UP MATERIAL:

Please refer to attached Change Order backup information compiled by Creighton Manning Engineering and Turner Construction.

989-SF CHANGE ORDER #012

ACAA CHANGE ORDER # 7

\$-162,000.00

- **Draft AIA to LeChase**
- **Draft AIA Tara Collins**
- **AIA Executed by LeChase**
- **AIA Executed by Turner Construction**
- **AIA Executed by CHA**
- **AIA Executed by ACAA**
- **Backup Provided for Depressurization Well Reimbursement**

To TBA 06/02/20

DRAFT AIA® Document G701/CMA™ - 1992

Change Order - Construction Manager-Adviser Edition

PROJECT <i>(Name and address):</i> Albany County Airport Authority Parking Garage: Sitework & Foundations 737 Albany Shaker Road Albany, New York 12211	CHANGE ORDER NUMBER: 012 INITIATION DATE: 06/02/20	OWNER: <input type="checkbox"/> CONSTRUCTION MANAGER: <input type="checkbox"/> ARCHITECT: <input type="checkbox"/> CONTRACTOR: <input type="checkbox"/> FIELD: <input type="checkbox"/> OTHER: <input type="checkbox"/>
TO CONTRACTOR <i>(Name and address):</i> LeChase Construction 1473 Erie Boulevard Schenectady, New York 12305	PROJECT NUMBERS: / 989-SF CONTRACT DATE: 02/27/19 CONTRACT FOR: Sitework & Foundations	

THE CONTRACT IS CHANGED AS FOLLOWS:

1. Reimbursement for failed Depressurization Well [Deduct \$162,000.00]

The original Contract Sum was	\$	8,821,000.00
Net change by previously authorized Change Orders	\$	730,823.04
The Contract Sum prior to this Change Order was	\$	9,551,823.04
The Contract Sum will be decreased by this Change Order in the amount of	\$	162,000.00
The new Contract Sum including this Change Order will be	\$	9,389,823.04

The Contract Time will be increased by Zero (0) days.
The date of Substantial Completion as of the date of this Change Order therefore is August 2, 2019.

NOTE: This summary does not reflect changes in the Contract Sum, Contract Time or Guaranteed Maximum Price which have been authorized by Construction Change Directive.

NOT VALID UNTIL SIGNED BY THE OWNER, CONSTRUCTION MANAGER, ARCHITECT AND CONTRACTOR.

<u>Turner Construction Company</u> CONSTRUCTION MANAGER <i>(Firm name)</i> 1 Computer Drive South Albany, New York 12205 ADDRESS	<u>CHA</u> ARCHITECT <i>(Firm name)</i> III Winners Circle Albany, New York 12205 ADDRESS
<u>Robert Wagner</u> BY <i>(Signature)</i> <i>(Typed name)</i> DATE:	<u>Rich LaRose, AIA</u> BY <i>(Signature)</i> <i>(Typed name)</i> DATE:
<u>LeChase Construction</u> CONTRACTOR <i>(Firm name)</i> 1473 Erie Boulevard Schenectady, New York 12305 ADDRESS	<u>Albany County Airport Authority</u> OWNER <i>(Firm name)</i> 737 Albany Shaker Road Albany, New York 12211 ADDRESS
<u>Neil Schiavi</u> BY <i>(Signature)</i> <i>(Typed name)</i> DATE:	<u>Phil Calderone</u> BY <i>(Signature)</i> <i>(Typed name)</i> DATE:



April 23, 2020

Mr. John LaClair, P.E., G.G.P.
Chief Engineer
Albany County Airport Authority
Albany International Airport
Administrative Building, Suite 20
Albany, NY 12211

□ Rec'd 04/23/20

**RE: Depressurization Well
New Parking Facility & Elevated Pedestrian Walkway
ACAA Contract 989-SF
CHA Project 35034**

Dear Mr. LaClair:

In accordance with Article 14, paragraph 14.6 (Rejecting Defective Work) of the above-referenced Contract between Albany County Airport Authority (the "Authority") and LeChase Construction Services LLC ("LeChase" or "Contractor"), CHA Consulting, Inc., as the Authority's Engineer/Architect for the Project, recommends that the Authority reject the depressurization well installed under the Contract by LeChase and LeChase's subcontractor, Ziegenfuss Drilling, Inc., for the reasons summarized below.

The Contractor failed to commence construction of the depressurization well within twelve hours of receiving direction to do so from the Engineer (CHA) as required by the Contract Documents. LeChase was directed to install the depressurization well on April 12, 2019, and well installation did not commence until April 19, 2019. While not meeting the installation deadline for the well did not impact the performance of the depressurization well itself, the timeframe to install the well resulted in continued erosion of the underlying clay confining layer around the pile for more than one month. The objective of being prepared and installing the well within 12 hours was specifically included to prevent erosion of the underlying clay formation by stopping the flow and allowing the natural clay to naturally expand and self-seal around the pile. With continuous flow occurring via the preferential pile pathway for more than a month, the underlying clay unit was eroded to the point that it prevented the potential for natural swelling and self-sealing around the pile. This required the Albany Airport Authority to expend significant additional funds to injection grout the pile to stop the flow of water and seal the pile.

The Contractor failed to install a functional production well capable of reducing groundwater flow to the surface by temporarily relieving the artesian groundwater pressure at pile cap A-7, as required by the Contract Documents.

- The depressurization well installed by the Contractor was not properly developed in accordance with Contract specification 33.11.11, Dewatering Well Installation, Section 3.1F, which required the well to be developed to obtain the optimum yield per foot of drawdown. The specification also required the removal of sand, rock fragments, clay and other undesirable material from the well efficiently and completely until the turbidity level is less than five (5) nephelometric

turbidity units (NTUs). Without adequate and proper development in accordance with the Contract specifications, a well screen can become fouled, reducing the well yield. This occurred with the well installed by the Contractor, as evidenced by the fact that the Contractor reported initial substantial yield followed by a rapid decrease in well production. Based on documentation provided by Turner Construction dated October 14, 2019, the discharge from the newly installed depressurization well installed by Ziegenfuss exhibited a very turbid discharge following

installation and several days following installation; ultimately until the flow from the well naturally decreased. Elevated turbidity is the primary indication of lack of well development and cause for well fouling. To date, LeChase has not provided any turbidity readings indicating the requirement of the specification were met, or that adequate well development efforts were performed by the contractor. The well screen appears to have become fouled both by material that should have been removed from the well during well development, as well as debris that was discarded into the well by the Contractor or its subcontractor during construction (a bag of garbage was removed from the well screen by LeChase's subcontractor during the well abandonment process).

Finally, the Contract Documents and information provided to the Contractor were clear and adequate to achieve the installation of a properly functioning well, as evidenced by the fact that, after LeChase's well failed, the Authority's separate Contractor, Hanson Well Drilling, was provided the same information and specification as LeChase, and successfully installed a functioning production well located approximately fifteen (15) feet from the well installed by LeChase.

For the foregoing reasons, we have concluded that the depressurization well was not properly installed by the Contractor as required by the Contract Documents, and that such improper performance of the work caused the well to fail. As such, and in accordance with Article 14, paragraph 14.6 of the Contract, we recommend that this work be rejected.

Sincerely,



Michael E. Hollowood, P.E.
Chief Civil Engineer



AIA Document G701/CMaTM - 1992

Change Order - Construction Manager-Adviser Edition

PROJECT (Name and address): Albany County Airport Authority Parking Garage: Sitework & Foundations 737 Albany Shaker Road Albany, New York 12211	CHANGE ORDER NUMBER: 001 INITIATION DATE: 07/05/2019	OWNER: <input type="checkbox"/> CONSTRUCTION MANAGER: <input type="checkbox"/> ARCHITECT: <input type="checkbox"/> CONTRACTOR: <input type="checkbox"/> FIELD: <input type="checkbox"/> OTHER: <input type="checkbox"/>
TO CONTRACTOR (Name and address): LeChase Construction 1473 Erie Boulevard Schenectady, New York 12305	PROJECT NUMBERS: / 989-SF CONTRACT DATE: 02/27/2019 CONTRACT FOR: Sitework & Foundations	

THE CONTRACT IS CHANGED AS FOLLOWS:

1. COR-009: Depressurization Well at A7 [Add \$162,000.00]
2. COR-003: Time and Material week ending 03.29.19 [Add \$14,719.21]
3. COR-005: Time and Material week ending 04.13.19 [Add \$20,850.61]

The original Contract Sum was	\$	8,821,000.00
Net change by previously authorized Change Orders	\$	0.00
The Contract Sum prior to this Change Order was	\$	8,821,000.00
The Contract Sum will be increased by this Change Order in the amount of	\$	197,569.82
The new Contract Sum including this Change Order will be	\$	9,018,569.82

The Contract Time will be increased by Zero (0) days.
The date of Substantial Completion as of the date of this Change Order therefore is August 2, 2019.

NOTE: This summary does not reflect changes in the Contract Sum, Contract Time or Guaranteed Maximum Price which have been authorized by Construction Change Directive.

NOT VALID UNTIL SIGNED BY THE OWNER, CONSTRUCTION MANAGER, ARCHITECT AND CONTRACTOR.

<u>Turner Construction Company</u> CONSTRUCTION MANAGER (Firm name) 1 Computer Drive South Albany, New York 12205 ADDRESS <i>[Signature]</i> BY (Signature) Robert Wagner (Typed name) DATE: 7-23-19	<u>CHA</u> ARCHITECT (Firm name) III Winners Circle Albany, New York 12205 ADDRESS <i>[Signature]</i> BY (Signature) Rich LaRose, AIA (Typed name) DATE: 8/2/19
<u>LeChase Construction</u> CONTRACTOR (Firm name) 1473 Erie Boulevard Schenectady, New York 12305 ADDRESS <i>[Signature]</i> BY (Signature) Neil Schiavi (Typed name) DATE: 7-23-19	<u>Albany County Airport Authority</u> OWNER (Firm name) 737 Albany Shaker Road Albany, New York 12211 ADDRESS <i>[Signature]</i> BY (Signature) John O'Donnell (Typed name) DATE: 10/17/19

AGENDA ITEM NO. 11.2

**Change Order #8: Authorization to award
Change Order #8 to Contract # 989-GCr New
Parking Garage (Gateway Sign) General
Construction to LeChase Construction
Services, LLC.**

AGENDA ITEM NO: 11.2
MEETING DATE: June 8, 2020

ALBANY COUNTY AIRPORT AUTHORITY
REQUEST FOR AUTHORIZATION

ACAA Approved
06/08/2020

DEPARTMENT:

Contact Person: *John LaClair, P.E., Chief Engineer*

PURPOSE OF REQUEST:

Change Order #8: *Authorization to award Change Order #8 to Contract # 989-GCr New Parking Garage (Gateway Sign) General Construction to LeChase Construction Services, LLC*

CONTRACT AMOUNT:

Base Amount:	\$15,700,000.00
Change Order #1:	\$ 60,694.95
Change Order #2:	\$ 56,318.00
Change Order #3:	\$ 338,604.00
Change Order #4:	\$ 163,353.00
Change Order #5:	\$ 235,334.00
Change Order #6:	\$ 96,755.00
Change Order #7:	\$ 243,199.05
Change Order #8:	<u>\$ 200,000.00*</u>
Total:	\$16,894,258.00

**Pending approval at this meeting.*

BUDGET INFORMATION:

Federal Airport Improvement Program
Anticipated in Current ALB Capital Plan: Yes No NA
Funding Account No.: CPN 2263

FISCAL IMPACT – FUNDING

Federal 2.0% State 35.4% Airport 62.6% NA _____
Term of Funding: 2018-2020
Grant No.: N/A State PIN: 1A00.97

JUSTIFICATION:

Request for authorization of Change Order #8 for Contract 989-GCr for New Parking Garage General Construction (Gateway Sign), to LeChase Construction Services LLC of Schenectady, N.Y. in the amount of \$200,000.00, Contract Incentive for early completion. The Contractor completed this project 20 days ahead of schedule, per the incentive \$10,000.00 a day to a maximum of \$200,000.00.

AGENDA ITEM NO: 11.2
MEETING DATE: June 8, 2020

CHIEF EXECUTIVE OFFICER'S RECOMMENDATION:

Recommend approval.

FINAL AGREEMENT SUBJECT TO APPROVAL BY COUNSEL: YES ✓ NA _____

PROCUREMENT DEPARTMENT APPROVAL:

Procurement complies with Authority Procurement Guidelines and Chief Financial Officer has approved. YES ✓ NO _____

BACK-UP MATERIAL:

Please refer to attached Change Order backup information compiled by Turner Construction.

989-GC CHANGE ORDER #015

ACAA CHANGE ORDER # 8

\$200,000.00

- **Draft AIA to LeChase**
- **Draft AIA Tara Collins**
- **AIA Executed by LeChase**
- **AIA Executed by Turner Construction**
- **AIA Executed by CHA**
- **AIA Executed by ACAA**
- **Backup Provided for COR-100, 128, 133, 134, 136 & Credit**

DRAFT

AIA® Document G701/CMA™ - 1992

Change Order - Construction Manager-Adviser Edition

PROJECT (Name and address): Albany County Airport Authority
 Parking Garage: General Construction
 737 Albany Shaker Road
 Albany, New York 12211

CHANGE ORDER NUMBER: 015
 INITIATION DATE: 05/04/20

OWNER:
 CONSTRUCTION MANAGER:
 ARCHITECT:
 CONTRACTOR:
 FIELD:
 OTHER:

TO CONTRACTOR (Name and address): LeChase Construction
 1473 Erie Boulevard
 Schenectady, New York 12305

PROJECT NUMBERS: / 989-GCr
 CONTRACT DATE: 05/02/19
 CONTRACT FOR: General Construction

THE CONTRACT IS CHANGED AS FOLLOWS:

- 01. COR-100: 989-GC Substantial Completion Bonus [Add \$200,000.00]
- 02. COR-128: Gateway Sign DOT Lighted Mock Up Request [Add \$1,238.00]
- 03. COR-133: Sign Light Support Detail [Add \$10,443.00]
- 04. COR-134: Generator Fuel Credit [Deduct \$572.00]
- 05. COR-136: Gateway Sign: White Vinyl Letters [Add \$851.00]
- 06. COR-###: Precast Cap [Deduct \$11,960.00]

The original Contract Sum was	\$ 15,700,000.00
Net change by previously authorized Change Orders	\$ 3,274,216.00
The Contract Sum prior to this Change Order was	\$ 18,974,216.00
The Contract Sum will be increased by this Change Order in the amount of	\$ 200,000.00
The new Contract Sum including this Change Order will be	\$ 19,174,216.00

The Contract Time will be increased by Zero (0) days.
 The date of Substantial Completion as of the date of this Change Order therefore is March 27,2020.

NOTE: This summary does not reflect changes in the Contract Sum, Contract Time or Guaranteed Maximum Price which have been authorized by Construction Change Directive.

NOT VALID UNTIL SIGNED BY THE OWNER, CONSTRUCTION MANAGER, ARCHITECT AND CONTRACTOR.

Turner Construction Company	CHA
CONSTRUCTION MANAGER (Firm name)	ARCHITECT (Firm name)
1 Computer Drive South	III Winners Circle
Albany, New York 12205	Albany, New York 12205
ADDRESS	ADDRESS

BY (Signature) Robert Wagner	BY (Signature) Rich LaRose, AIA
(Typed name) DATE:	(Typed name) DATE:

LeChase Construction	Albany County Airport Authority
CONTRACTOR (Firm name)	OWNER (Firm name)
1473 Erie Boulevard	737 Albany Shaker Road
Schenectady, New York 12305	Albany, New York 12211
ADDRESS	ADDRESS

BY (Signature) Neil Schiavi	BY (Signature) Phil Calderone
(Typed name) DATE:	(Typed name) DATE:

the 1990s, the number of people with a diagnosis of schizophrenia has increased in many countries (Murray & Lopez, 1996).

There is a need to understand the nature of the illness and the reasons for its increasing prevalence. This paper reports on a study of the experience of people with schizophrenia, and the reasons for their illness.

The paper is organized as follows. First, we describe the study and then discuss the results. Finally, we discuss the implications of the findings.

Method

Participants

The study was carried out in a psychiatric hospital in London. The participants were 10 people with a diagnosis of schizophrenia.

The participants were recruited through the hospital's outpatient clinic. They were approached by a research fellow who was a member of the hospital's staff.

The participants were interviewed in a room in the hospital. The interviews were conducted by a research fellow who was not a member of the hospital's staff.

The participants were interviewed between 1998 and 2000. The interviews lasted between 30 and 60 minutes.

The participants were interviewed in a room in the hospital. The interviews were conducted by a research fellow who was not a member of the hospital's staff.

The participants were interviewed between 1998 and 2000. The interviews lasted between 30 and 60 minutes.

The participants were interviewed in a room in the hospital. The interviews were conducted by a research fellow who was not a member of the hospital's staff.

The participants were interviewed between 1998 and 2000. The interviews lasted between 30 and 60 minutes.

The participants were interviewed in a room in the hospital. The interviews were conducted by a research fellow who was not a member of the hospital's staff.

The participants were interviewed between 1998 and 2000. The interviews lasted between 30 and 60 minutes.

The participants were interviewed in a room in the hospital. The interviews were conducted by a research fellow who was not a member of the hospital's staff.

The participants were interviewed between 1998 and 2000. The interviews lasted between 30 and 60 minutes.

The participants were interviewed in a room in the hospital. The interviews were conducted by a research fellow who was not a member of the hospital's staff.

The participants were interviewed between 1998 and 2000. The interviews lasted between 30 and 60 minutes.

The participants were interviewed in a room in the hospital. The interviews were conducted by a research fellow who was not a member of the hospital's staff.

The participants were interviewed between 1998 and 2000. The interviews lasted between 30 and 60 minutes.

The participants were interviewed in a room in the hospital. The interviews were conducted by a research fellow who was not a member of the hospital's staff.

The participants were interviewed between 1998 and 2000. The interviews lasted between 30 and 60 minutes.

The participants were interviewed in a room in the hospital. The interviews were conducted by a research fellow who was not a member of the hospital's staff.

The participants were interviewed between 1998 and 2000. The interviews lasted between 30 and 60 minutes.

The participants were interviewed in a room in the hospital. The interviews were conducted by a research fellow who was not a member of the hospital's staff.

The participants were interviewed between 1998 and 2000. The interviews lasted between 30 and 60 minutes.



March 9, 2020

John LaClair, P.E., G.G.P.
Chief Engineer
Albany County Airport Authority

Attn: John LaClair

Reference: Albany Airport Parking Garage General Construction 989-GCR
Letter of Substantial Completion

Dear Mr. LaClair:

This letter is to inform Albany Airport Authority that LeChase Construction Services, LLC is **substantially complete** with the construction of the General Construction for the Parking Garage, Pedestrian Bridge and Sitework as of **March 6, 2020**. The Garage, Pedestrian Bridge and Sitework packages have been constructed in accordance with the project's drawings and specifications. The following items are still in construction due to design related issues, work not complete due to coordination with trades working under separate contract or change order work:

1. Garage Ramp Roof (Structure, Roof, Paint & Lights) – Targeted to be completed prior to 3/27/20
2. SACO Lighting – Targeted to be completed prior to 3/27/20
3. Elevator Coordination Fire Alarm – To be completed in conjunction with Kone
4. Sign Coordination Work – To be completed in conjunction with Sign Contractor

LeChase is requesting a final punchlist from your design teams by 3/13/20 so we can work diligently to complete any remaining punchlist items that have been indicated or are addressed by the architect/design team and during the final walk with the county inspectors.

Please contact me with any questions. Thanks.

Respectfully,

A handwritten signature in black ink, appearing to read 'Ryan Faulkner'.

Ryan Faulkner, CPC
Project Executive

CC: Neil Schiavi

4.1 SUBSTANTIAL AND FINAL COMPLETION

The parking garage and pedestrian bridge elevators shall be completed, turned over and operational for use no later than December 31, 2019 for the bonus/penalty of \$5,000/day. This bonus/penalty has a maximum duration of 20 days.

The parking garage, pedestrian bridge and vehicular bridge must be ready for occupancy and public use no later than end of business March 27, 2020 for the bonus/penalty of \$10,000/day. This bonus/penalty has a maximum duration of 20 days.

4.2 LIQUIDATED DAMAGES

AUTHORITY and CONTRACTOR recognize that time is of the essence of this Agreement and that the AUTHORITY will suffer financial loss if the Work is not completed within the times specified in paragraph 4.1 above, plus any extensions thereof allowed in accordance with Article 17. They also recognize that it is and will be impracticable or extremely difficult to ascertain the actual damages which the AUTHORITY will sustain, which may include, but are not limited to:

1. Delays in the completion and subsequent operation of the AUTHORITY's Airport Facilities;
2. Unreasonable inconvenience to the public;
3. Loss of revenue;
4. Increased costs for Agreement administration; and
5. Delays and increased costs to other contractors.

Accordingly, instead of requiring such ascertainment of actual damages, AUTHORITY and CONTRACTOR agree that CONTRACTOR shall pay AUTHORITY as Liquidated Damages for delay (but not as a penalty) an amount specified in the Schedule of Liquidated Damages below for each Calendar Day that expires after the time specified in paragraph 4.1 for Substantial Completion until the Work (or specified portion thereof) is substantially complete.

After Final Completion, if CONTRACTOR shall neglect, refuse, or fail to complete the remaining Work (or specified portion thereof) within the time specified in paragraph 4.1 for completion and readiness for final payment or any proper extension thereof granted by AUTHORITY, CONTRACTOR shall pay AUTHORITY as Liquidated Damages for delay (but not as a penalty) an amount specified in the Schedule of Liquidated Damages, above, for each Calendar Day that expires after the time specified in paragraph 4.1 for completion and readiness for final payment. The AUTHORITY may deduct the sum of Liquidated Damages from any monies due or that may become due the CONTRACTOR; or if such monies are insufficient, the CONTRACTOR or its Surety shall pay to the AUTHORITY any deficiency. The Liquidated Damages specified in this Agreement do not include any penalties. The CONTRACTOR and the AUTHORITY acknowledge that the amount of Liquidated Damages set forth in this Agreement represents a good faith estimate as to the actual potential damages the AUTHORITY would incur as a result of the late completion of the Work or portions thereof. The remedies specified herein are not exclusive, and are in addition to other rights and remedies provided by law or stipulated under this Agreement. The CONTRACTOR is responsible and liable for said Liquidated Damages even in the event that the CONTRACTOR abandons the performance of the contract or the CONTRACTOR's employment is terminated pursuant to the provisions of this Agreement.

Change Order Request

LeChase Construction Services, LLC
 220 Harborside Drive, Suite 301
 Schenectady, NY 12305
 Phone: 518-388-9200

Date: 4/14/2020

Owner : Albany County Airport Authority

Project: 1934006 - Albany Airport Parking Garage - 989-GCR

Reason:

Change Order Request # : 128 - PCO 187 - Mockup International Sign & Lights

Description of Change: This COR is to hook up Albany International Airport Sign temporarily for a mockup at the request of the DOT.

The Gateway sign project had been shut down previously do to Covid-19, at the request of the DOT they wanted to review the sign lighting while the structure remained stationed on the truck. We remobilized our electricians and sign teams to complete the work in order for an onsite review to take place. A mock was not initially included in our contract work.

Description	Scope of Work	Cost
Gateway Signage		1,161.00
Subtotal of Costs		1,161.00

Change Order Add Ons

Fee	58.00
GL Insurance	12.00
P&P Bond	7.00

Total For Change Order Request **1,238.00**

Albany County Airport Authority

LeChase Construction Services, LLC

Other: If Applicable

Print: _____

Print: _____

Print: _____

Signed: _____

Signed: _____

Signed: _____

Date: _____

Date: _____

Date: _____

Change Order Request - Temporary Lighting of Signs **4/8/2020**
SAXTON CORPORATION OF ALBANY

<u>DESCRIPTION</u>	<u>RATES</u>	<u>Hours</u>	<u>COST</u>
Electrician - Rate (Jeremy Bertran)	\$ 89.68	6.50	\$ 582.92
Truck-Flatbed with Aerial Lift (Based on 2019 FEMA Equipment Rates)	\$ 51.99	6.50	\$ 337.94
Generator Rental (Based on 2019 FEMA Equipment Rates)	\$ 5.36	6.50	\$ 34.84
TRAVEL FEE (1/2 hr each way)	\$ 100.00	1.00	\$ 100.00
			\$ 1,055.70
OVERHEAD & PROFIT	10.00%		\$ 105.57
			<u>\$ 1,161.26</u>

Approved BY : _____

Date: _____

Change Order Request

05-13-20 Email to Review Process.

LeChase Construction Services, LLC
 220 Harborside Drive, Suite 301
 Schenectady, NY 12305
 Phone: 518-388-9200

Date: 4/29/2020

Owner : Albany County Airport Authority

Project: 1934006 - Albany Airport Parking Garage - 989-GCR

Reason:

Change Order Request # : **133 - PCO 196 - Sign Light Support Detail**

Description of Change: This COR is for all additional work associated with sign supports to allow light fixtures to be installed. The contract documents specify clearly that all signs are to be design and installed to meet DOT standard sign details, which has been provided. There are zero notes on the sign drawings that required and structure for lights to be installed. On sheet E-601 there is a standard detail showing the light attaching to a "sign brace", which now also requires the post to be taller than standard DOT post heights. The detail on this sheet does not specify a material to be used and furthermore the lengths of the cross braces would have been wrong as the dimensions on the lights are actually longer than the design team indicated and will extend past the. The cantilever sign design has no design support detail. After further clarification has been provided they have now specified a 3/8" galvanized plate to be installed 9" tall x length of fixture + boxes x2 + 1/2" either side....The detail provided at bid time clearly doesn't show that. LeChase is in agreement that although the design is lacking coordination and a significant amount of detail that we owe you something at all ground level signs, but not to the extent that the designer has asked for in April 2020 and the cantilever had no design. We would agree to install a Unistrut support off existing sign posts at No Cost. We considered this means and methods based off the lack of information in a hard bid project.

*E-601 shows "sign post" extending up
 E-601 had lights for cantilever signs*

LeChase has priced the new design concepts with Saxton sign and their cost to complete this detail is \$20,535. LeChase will agree to offset a portion of that cost by 50% and will not charge markup. So, we will provide this new detail for a cost of \$10,267.

This is a 2-3 week lead time and we will proceed once we have approved change order. If you would like to move forward at the no cost option, please advise and we will proceed next week.

Description	Scope of Work	Cost
Gateway Signage	<i>- LeChase stated it was approx. \$14,000 (04.27.20) and they would be in (04.24.20) for \$6,000</i>	10,267.00
	Subtotal of Costs	10,267.00
	Change Order Add Ons	
	Fee	0.00
	GL Insurance	110.00
	P&P Bond	66.00
	Total For Change Order Request	10,443.00

lack of coordination on drawings but lack of coordination from LCS for signage + lighting

Albany County Airport Authority	LeChase Construction Services, LLC	Other: If Applicable
Print: _____	Print: _____	Print: _____
Signed: _____	Signed: _____	Signed: _____
Date: _____	Date: _____	Date: _____

PROJECT

PHASE

ORG

COMPLETED BY:

D. Osted

CHECKED BY:

35034

PROJECT NAME:

Albany Airport

SHEET #

OF

DATE:

PROJECT LOCATION:

Albany, NY

SUBJECT:

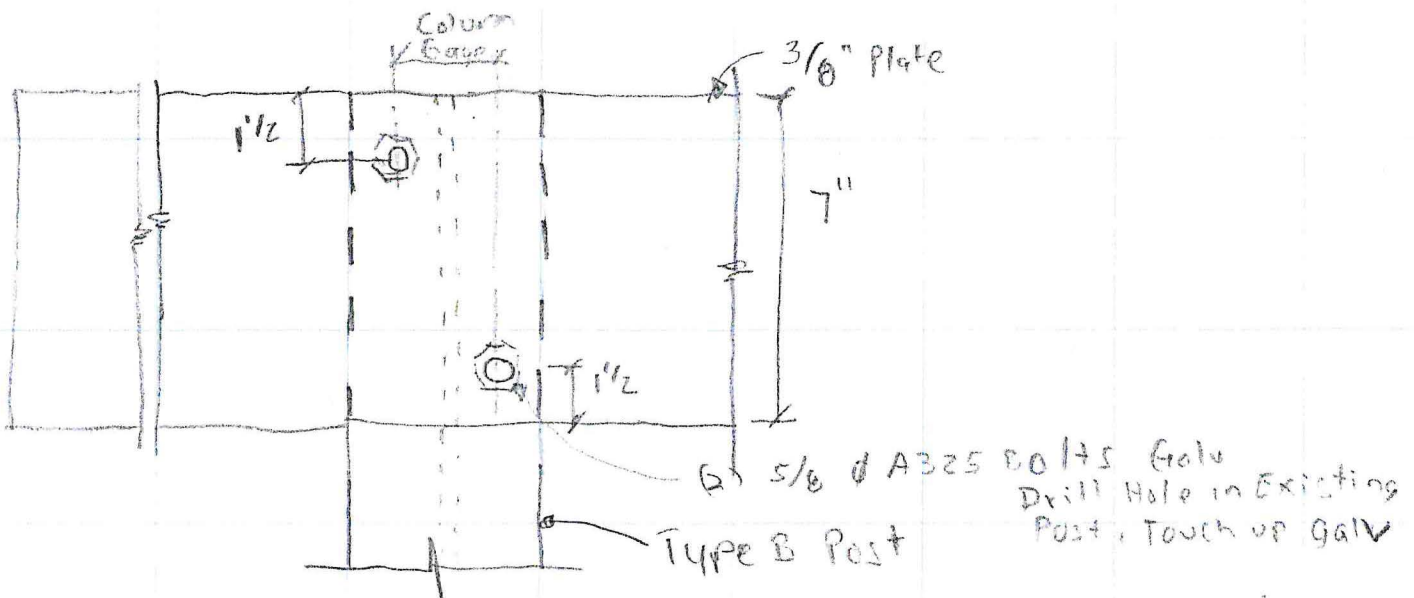
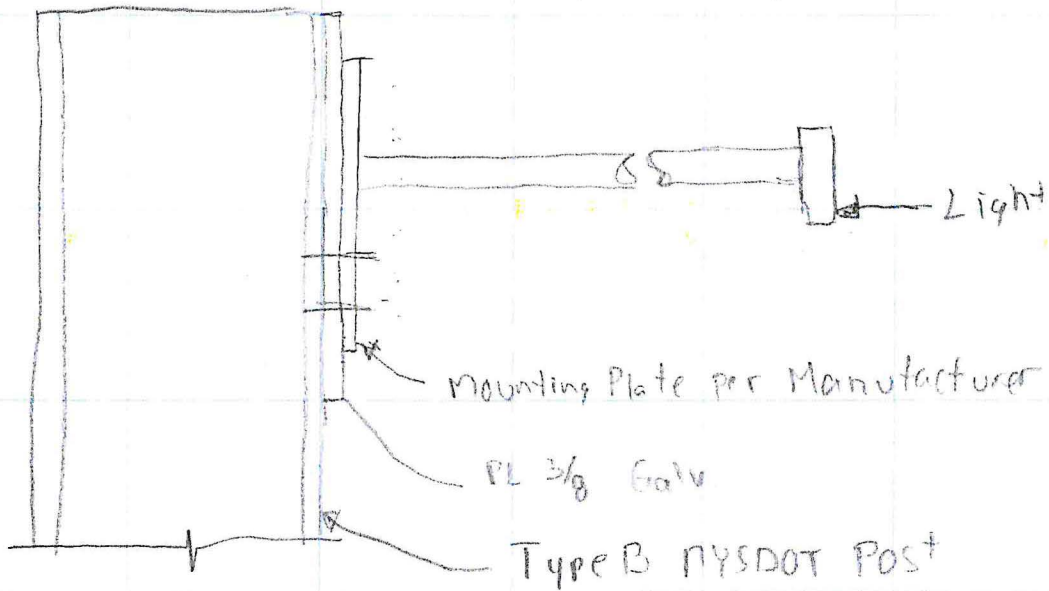

Coordinate Location of
Mounting Plates with Plate Attached
to the Column

Sign No.	Actual Sign Length	3/8" Plate Length (including extra 2")	3/8" plate width (including extra 1")	Added Length of Type B Post	Light size without mounting legs
F	7'-3"	8'-8"	9"	19"	7'-11 1/2"
G	7'-3"	8'-5"	9"	19"	7'-11 1/2"
H	7'-6"	8'-8"	9"	19"	7'-11 1/2"
I (Need Type B Posts)	6'-1"	5'-9 1/4"	9"	19"	5'- 1/2"
K (Need Type B Posts)	6'-5"	7'-8 1/4"	9"	19"	6' 11 3/4"
M (Cantilever)	8'-6"	8'-5"	9"	19"	7'-11 1/2"
N (Cantilever)	8'-6"	8'-8"	9"	19"	7'-11 1/2"

2 Extra lights fixtures 7'-11 1/2"

Sign F & G

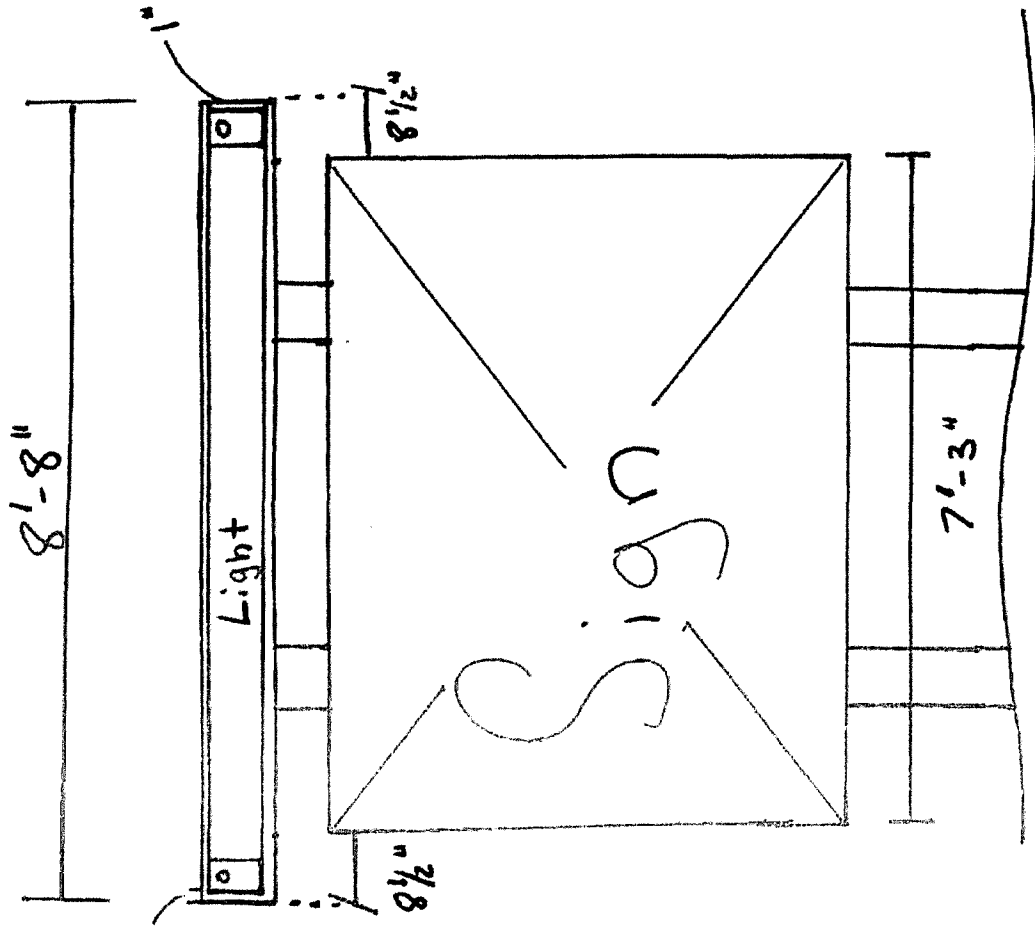

Front face view

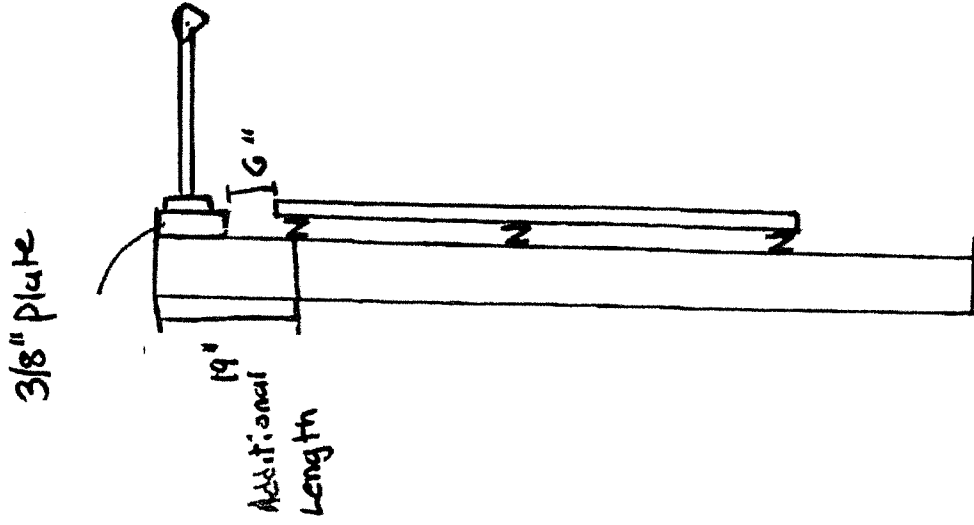

Side view

Sign H

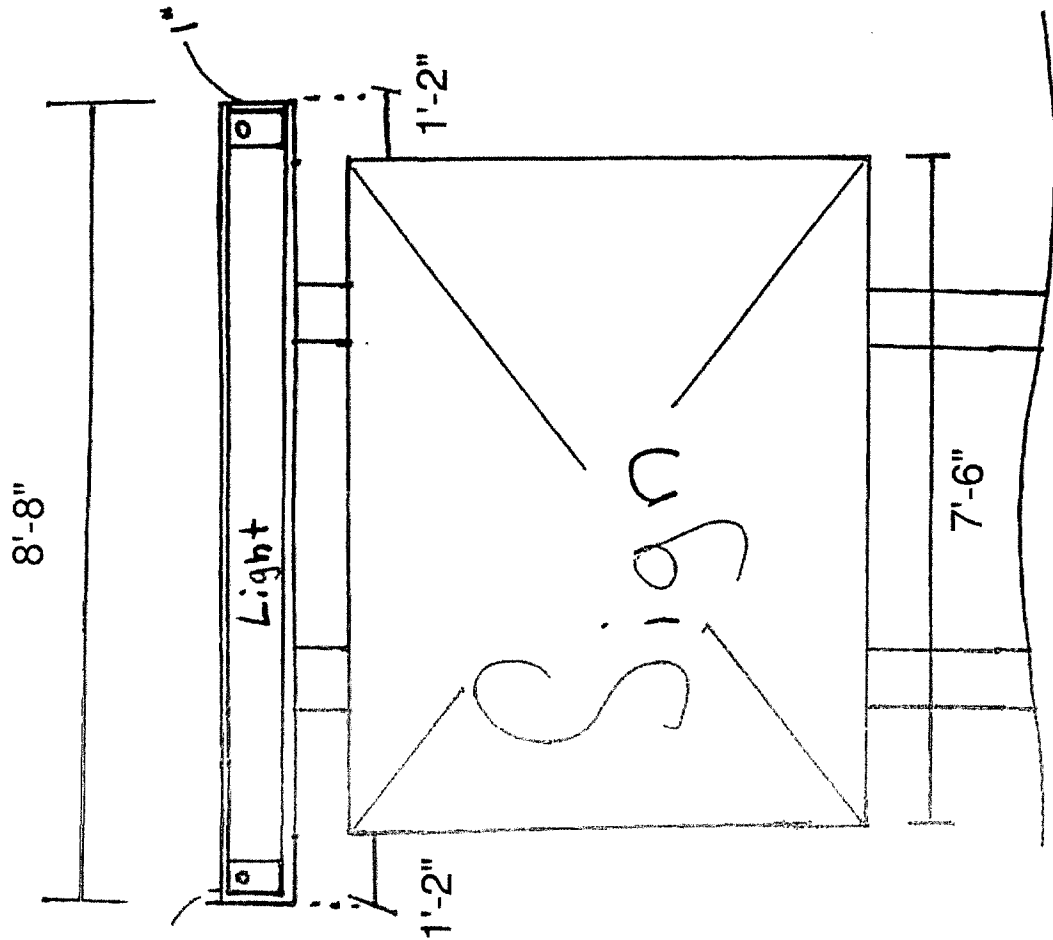

Front face view

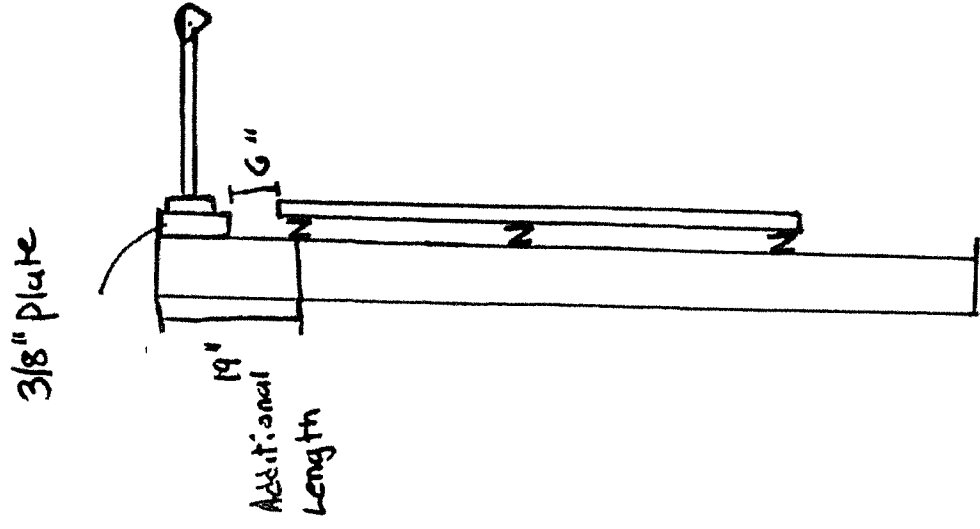

Side view

Sign I

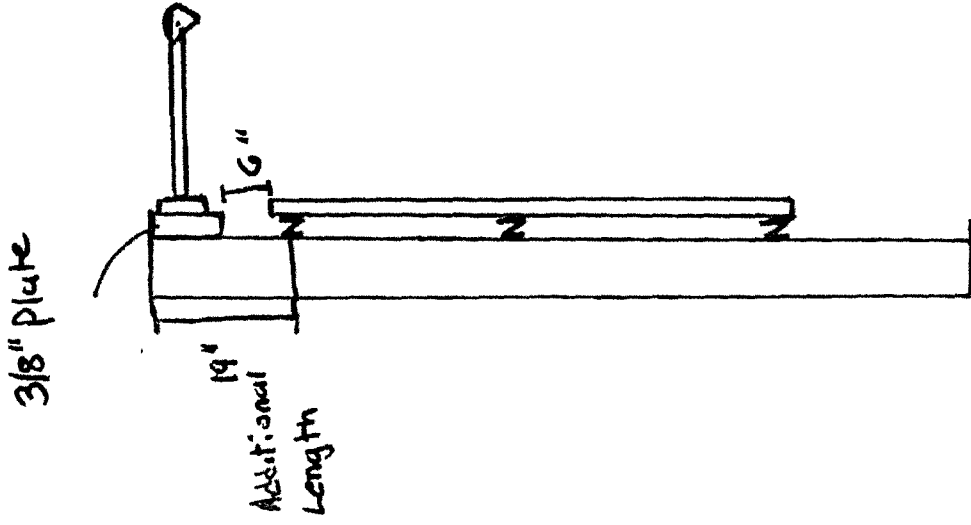

Side view

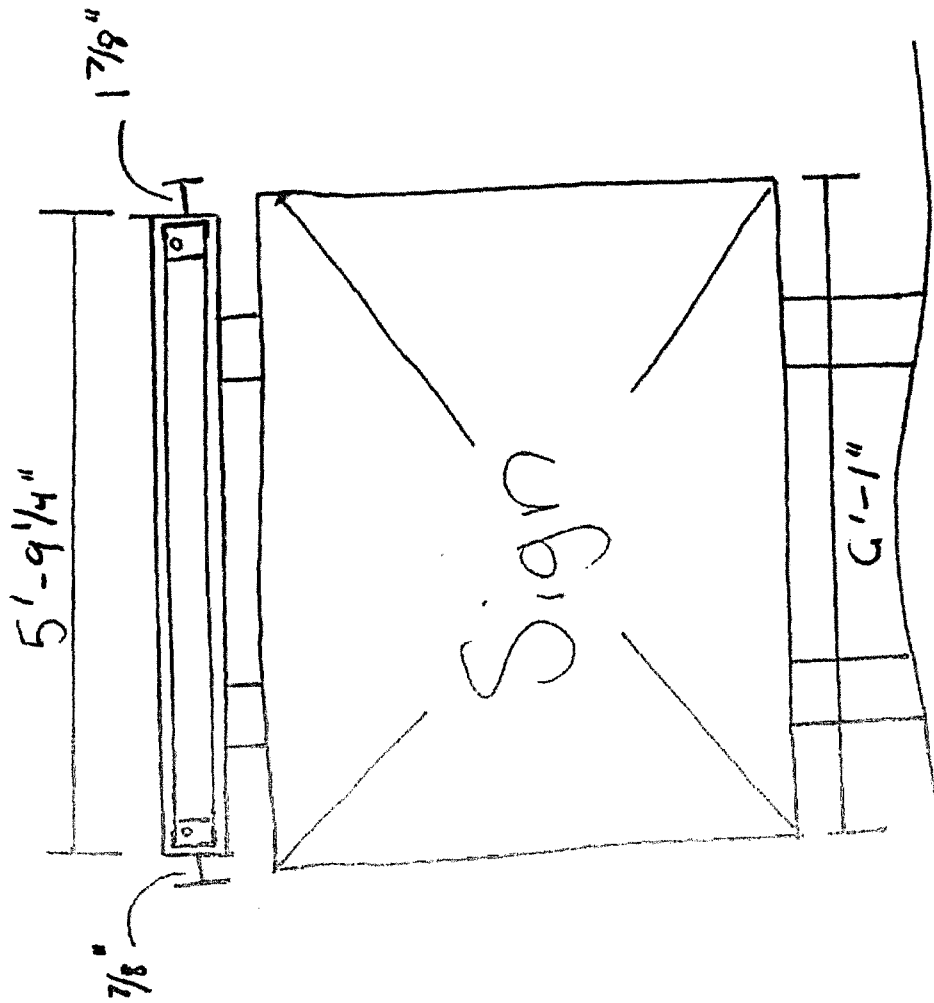

Front face view

Sign K

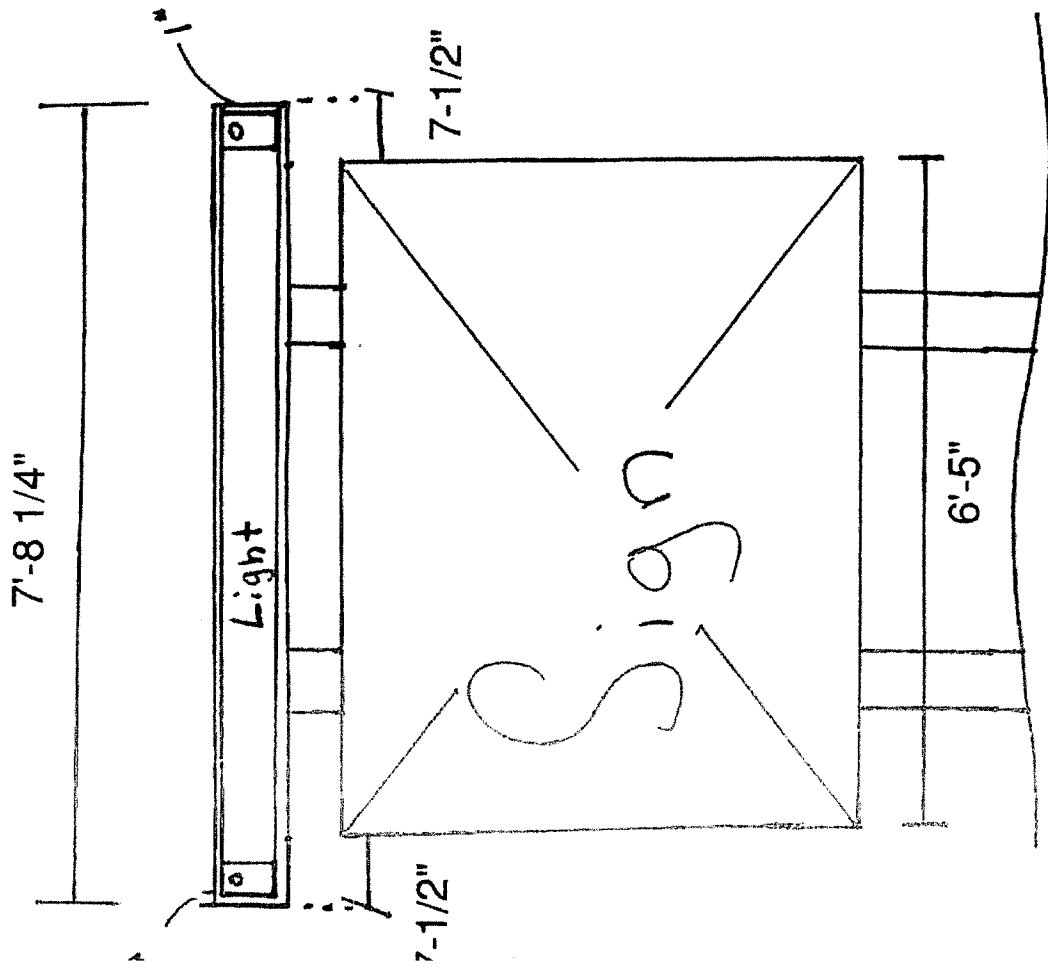

Front face view

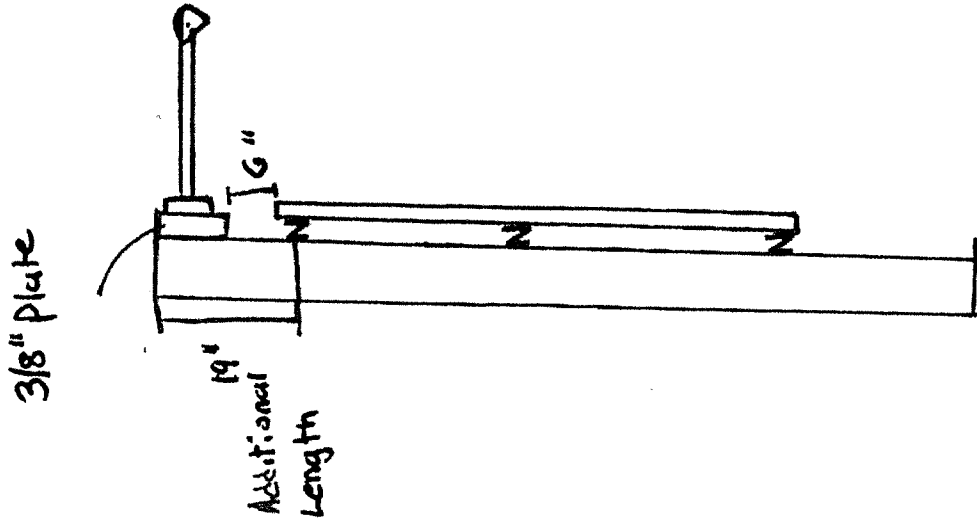

Side view

SAXTON SIGN CORPORATION

1320 Route 9 Castleton, NY 12033

Telephone: (518) 732-7704 (800) 942-6366

Fax: 518-732-7716

TO:

LeChase Construction

LETTER OF TRANSMITTAL

DATE: 04/28/2020	JOB NO.
ATTENTION: Ryan Faulkner	
Zachary Johnson	
RE: Albany Airport Extending	
DOT Signs	

WE ARE SENDING YOU the following items:

Attached Under separate cover via

Shop Drawings Prints Plans Samples Specifications
 Copy of letter Change order Other Price Quote

COPIES	DATE	NO.	DESCRIPTION

THESE ARE TRANSMITTED as checked below:

For approval Approved as submitted Resubmit _____ copies for approval
 For your use Approved as noted Submit _____ copies for distribution
 As requested Returned for corrections Return _____ corrected prints
 For review and comment Other _____

FOR BIDS DUE PRINTS RETURNED AFTER LOAN TO US

REMARKS:

Sign "M" add additional zee bar to support new galvanized plate 3/8" x 9"H x 8'8"L for mounting light fixture to. <i>Compliar</i>	Materials \$1,434.00	Labor \$2,667.00	= \$4,101.00
Sign "N" add additional zee-bar to support new galvanized plate 3/8" x 9"H x 8'8"L <i>should be equal</i>	Materials \$1,085.00	Labor \$2,667.00	= \$3,752.00
Signs F, G, H, I, & K extend type B posts 4" x 6" I-beams 19"H add galvanized plates for mounting lights by others.	Materials \$ 941.50	Labor \$1,611.00	= \$2,552.50
Sign "F" galv. Plate 3/8" x 9" x 8'8"L	Materials \$ 941.50	Labor \$1,611.00	= \$2,552.50
Sign "G" galv. Plate 3/8" x 9" x 8'8"L	Materials \$ 941.50	Labor \$1,611.00	= \$2,552.50
Sign "H" galv. Plate 3/8" x 9" x 8'8"L	Materials \$ 882.00	Labor \$1,611.00	= \$2,493.00
Sign "I" galv. Plate 3/8" x 9" x 5' 9-1/4"L	Materials \$ 921.00	Labor \$1,611.00	= \$2,532.00
Sign "K" galv. Plate 3/8" x 9" x 7' 8-1/4"L	TOTAL		= \$20,535.50

**No Safety man provided with these prices.

**Price does not include NYS Sales Tax or permits, if applicable

COPY TO File

SIGNED *Jack Condron*
Jack Condron

If enclosures are not as noted, kindly notify us at once

the 1990s, the number of people in the world who are living in poverty has increased from 1.1 billion to 1.5 billion (World Bank 2000).

There are a number of reasons for this increase. One of the main reasons is the rapid population growth in the developing world. The number of people in the world is expected to reach 8 billion by the year 2025 (United Nations 2000). This increase in population will put a tremendous strain on the world's resources, particularly in the developing world.

Another reason for the increase in poverty is the rapid technological change in the developed world. The developed world has experienced a rapid increase in technological change, which has led to a rapid increase in productivity. This increase in productivity has led to a rapid increase in the standard of living in the developed world, but it has also led to a rapid increase in the standard of living in the developing world.

There are a number of reasons for this increase. One of the main reasons is the rapid population growth in the developing world. The number of people in the world is expected to reach 8 billion by the year 2025 (United Nations 2000). This increase in population will put a tremendous strain on the world's resources, particularly in the developing world.

Another reason for the increase in poverty is the rapid technological change in the developed world. The developed world has experienced a rapid increase in technological change, which has led to a rapid increase in productivity. This increase in productivity has led to a rapid increase in the standard of living in the developed world, but it has also led to a rapid increase in the standard of living in the developing world.

There are a number of reasons for this increase. One of the main reasons is the rapid population growth in the developing world. The number of people in the world is expected to reach 8 billion by the year 2025 (United Nations 2000). This increase in population will put a tremendous strain on the world's resources, particularly in the developing world.

Another reason for the increase in poverty is the rapid technological change in the developed world. The developed world has experienced a rapid increase in technological change, which has led to a rapid increase in productivity. This increase in productivity has led to a rapid increase in the standard of living in the developed world, but it has also led to a rapid increase in the standard of living in the developing world.

There are a number of reasons for this increase. One of the main reasons is the rapid population growth in the developing world. The number of people in the world is expected to reach 8 billion by the year 2025 (United Nations 2000). This increase in population will put a tremendous strain on the world's resources, particularly in the developing world.

Another reason for the increase in poverty is the rapid technological change in the developed world. The developed world has experienced a rapid increase in technological change, which has led to a rapid increase in productivity. This increase in productivity has led to a rapid increase in the standard of living in the developed world, but it has also led to a rapid increase in the standard of living in the developing world.

There are a number of reasons for this increase. One of the main reasons is the rapid population growth in the developing world. The number of people in the world is expected to reach 8 billion by the year 2025 (United Nations 2000). This increase in population will put a tremendous strain on the world's resources, particularly in the developing world.

Another reason for the increase in poverty is the rapid technological change in the developed world. The developed world has experienced a rapid increase in technological change, which has led to a rapid increase in productivity. This increase in productivity has led to a rapid increase in the standard of living in the developed world, but it has also led to a rapid increase in the standard of living in the developing world.

There are a number of reasons for this increase. One of the main reasons is the rapid population growth in the developing world. The number of people in the world is expected to reach 8 billion by the year 2025 (United Nations 2000). This increase in population will put a tremendous strain on the world's resources, particularly in the developing world.

Change Order Request

LeChase Construction Services, LLC
220 Harborside Drive, Suite 301
Schenectady, NY 12305
Phone: 518-388-9200

Date: 5/11/2020

Owner : Albany County Airport Authority

Project: 1934006 - Albany Airport Parking Garage - 989-GCR

Reason:

Change Order Request # : 134 - PCO 197- Generator Fuel Tank Credit

Description of Change: Provide credit for the reduced amount of fuel provided for the engine generator.

Description	Scope of Work	Cost
Electrical	731 gallons original capacity 351 gallons new capacity 386 gallons delta @ \$1.39/gallon (off road diesel priced this morning from my supplier) = \$537.	-537.00
	Subtotal of Costs	-537.00
	<u>Change Order Add Ons</u>	
	Fee	-26.00
	GL Insurance	-6.00
	P&P Bond	-3.00
	Total For Change Order Request	-572.00

Albany County Airport Authority

LeChase Construction Services, LLC

Other: If Applicable

Print: _____

Print: _____

Print: _____

Signed: _____

Signed: _____

Signed: _____

Date: _____

Date: _____

Date: _____



Get Comfortable...
Stay Comfortable

To Whom It May Concern:

May 11, 2020

Price quoted for off-road diesel is \$1.30 per gallon plus any applicable taxes.
That is not a lock in price, that is based off today's market price.

Thank you,

G.A. Bove Fuels

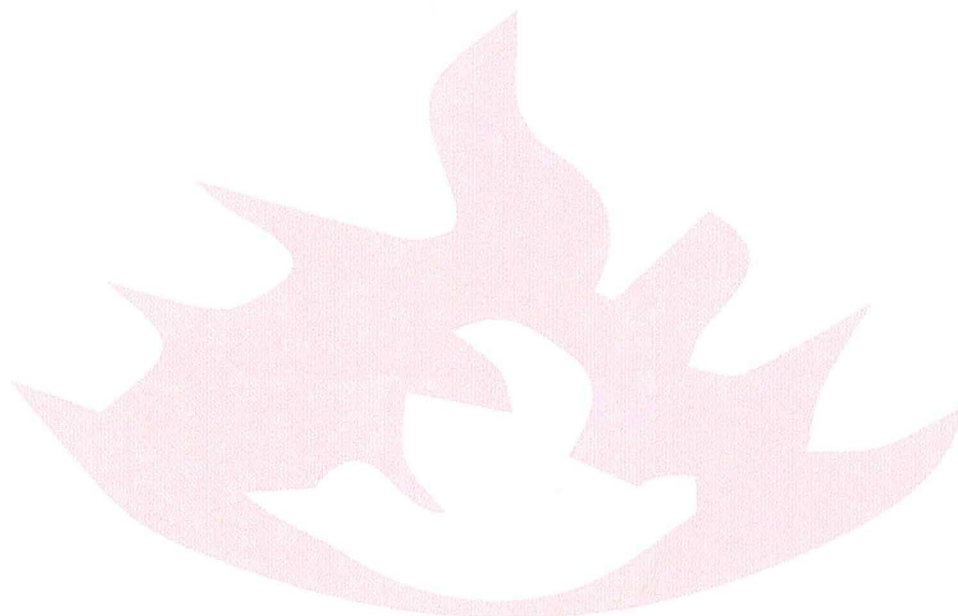

76 Railroad St. Mechanicville, NY 12118
(518) 664-5111

40 Derby St. Hudson Falls, NY 12839
(518) 747-7761

1537 Rt. 30 Wells, NY 12190
(518) 924-2052

www.bovefuels.com

Change Order Request

LeChase Construction Services, LLC
220 Harborside Drive, Suite 301
Schenectady, NY 12305
Phone: 518-388-9200

Date: 5/19/2020

Owner : Albany County Airport Authority

Project: 1934006 - Albany Airport Parking Garage - 989-GCR

Reason:

Change Order Request # : 136 - PCO 199- Gatway Sign Letters

Description of Change: Remove existing purple lettering on the "international" portion of the Gateway sign. Furnish and install white lettering in place of the existing purple lettering.

Description	Scope of Work	Cost
Gateway Signage		797.00
Subtotal of Costs		797.00

Change Order Add Ons

Fee	40.00
GL Insurance	9.00
P&P Bond	5.00

Total For Change Order Request **851.00**

Albany County Airport Authority

LeChase Construction Services, LLC

Other: If Applicable

Print: _____

Print: _____

Print: _____

Signed: _____

Signed: _____

Signed: _____

Date: _____

Date: _____

Date: _____

SAXTON SIGN CORPORATION

1320 Route 9 Castleton, NY 12033

Telephone: (518) 732-7704 (800) 942-6366

Fax: 518-732-7716

TO:

LeChase Construction

LETTER OF TRANSMITTAL

DATE: 05/20/2020	JOB NO.
ATTENTION: Ryan Faulkner	
Zac Johnson	
RE: Gateway Sign	
Face color change on the	
"International" letters	
Revised	

WE ARE SENDING YOU the following items:

Attached Under separate cover via

Shop Drawings Prints Plans Samples Specifications
 Copy of letter Change order Other Price Quote

COPIES	DATE	NO.	DESCRIPTION

THESE ARE TRANSMITTED as checked below:

For approval Approved as submitted Resubmit _____ copies for approval
 For your use Approved as noted Submit _____ copies for distribution
 As requested Returned for corrections Return _____ corrected prints
 For review and comment Other _____
 FOR BIDS DUE _____ PRINTS RETURNED AFTER LOAN TO US _____

REMARKS

For changing the face color to white on the Gateway sign "International" letters:

Using white vinyl (will hold-up longer than paint)

Materials	\$ 247.00
Labor	\$ 550.00
Total =	\$ 797.00

*Work to be done in back Parking area before sign structure is moved

*No Safety man to be provided

**Price does not include NYS Sales Tax or permits, if applicable

COPY TO File

SIGNED

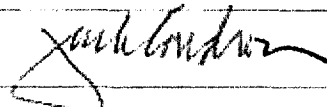

Jack Condron

If enclosures are not as noted, kindly notify us at once

Change Order Request

LeChase Construction Services, LLC
220 Harborside Drive, Suite 301
Schenectady, NY 12305
Phone: 518-388-9200

Date: 5/19/2020

Owner : Albany County Airport Authority

Project: 1934006 - Albany Airport Parking Garage - 989-GCR

Reason:

Change Order Request # : 136 - PCO 199- Gatway Sign Letters

Description of Change: Remove existing purple lettering on the "international" portion of the Gateway sign. Furnish and install white lettering in place of the existing purple lettering.

Description	Scope of Work	Cost
Gateway Signage		1,247.00
	Subtotal of Costs	1,247.00
Change Order Add Ons		
	Fee	62.00
	GL Insurance	13.00
	P&P Bond	8.00
	Total For Change Order Request	1,330.00

VOID

Albany County Airport Authority

LeChase Construction Services, LLC

Other: If Applicable

Print: _____

Print: _____

Print: _____

Signed: _____

Signed: _____

Signed: _____

Date: _____

Date: _____

Date: _____

SAXTON SIGN CORPORATION

1320 Route 9 Castleton, NY 12033

Telephone: (518) 732-7704 (800) 942-6366

Fax: 518-732-7716

TO:

LeChase Construction

LETTER OF TRANSMITTAL

DATE: 05/12/2020	JOB NO.
ATTENTION: Ryan Faulkner Zac Johnson	
RE: Gateway Sign	
Face color change on the	
"International" letters	

WE ARE SENDING YOU the following items:

- Attached Under separate cover via
 Shop Drawings Prints Plans Samples Specifications
 Copy of letter Change order Other Price Quote

COPIES	DATE	NO.	DESCRIPTION

THESE ARE TRANSMITTED as checked below:

- For approval Approved as submitted Resubmit _____ copies for approval
 For your use Approved as noted Submit _____ copies for distribution
 As requested Returned for corrections Return _____ corrected prints
 For review and comment Other _____
 FOR BIDS DUE _____ PRINTS RETURNED AFTER LOAN TO US _____

REMARKS

For changing the face color to white on the Gateway sign "International" letters:

Using white vinyl (will hold-up longer than paint)

Materials \$ 247.00

Labor \$1,000.00

Total = \$1,247.00

*Work to be done in back Parking area before sign structure is moved

*No Safety man to be provided

**Price does not include NYS Sales Tax or permits, if applicable

COPY TO File

SIGNED

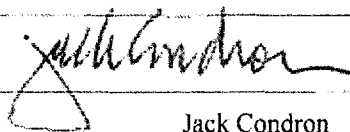
Jack Condon

If enclosures are not as noted, kindly notify us at once

Table 1. Mean (SD) values for the dependent variables in the three conditions. The dependent variables were defined in the text. The dependent variables were measured at the end of the 10-min test period

Condition	HR (b/min)	VO ₂ (l/min)	VO ₂ (ml/kg/min)	VO ₂ (ml/min)	VO ₂ (ml/kg/min)	VO ₂ (ml/min)	VO ₂ (ml/kg/min)	VO ₂ (ml/min)	VO ₂ (ml/kg/min)
Control	138 (12)	22.5 (2.2)	22.5 (2.2)	22.5 (2.2)	22.5 (2.2)	22.5 (2.2)	22.5 (2.2)	22.5 (2.2)	22.5 (2.2)
Control + 100 mg/kg	138 (12)	22.5 (2.2)	22.5 (2.2)	22.5 (2.2)	22.5 (2.2)	22.5 (2.2)	22.5 (2.2)	22.5 (2.2)	22.5 (2.2)
Control + 200 mg/kg	138 (12)	22.5 (2.2)	22.5 (2.2)	22.5 (2.2)	22.5 (2.2)	22.5 (2.2)	22.5 (2.2)	22.5 (2.2)	22.5 (2.2)

HR = heart rate; VO₂ = oxygen consumption.

HR = heart rate; VO₂ = oxygen consumption.

HR = heart rate; VO₂ = oxygen consumption.

HR = heart rate; VO₂ = oxygen consumption.

HR = heart rate; VO₂ = oxygen consumption.

HR = heart rate; VO₂ = oxygen consumption.

HR = heart rate; VO₂ = oxygen consumption.

HR = heart rate; VO₂ = oxygen consumption.

HR = heart rate; VO₂ = oxygen consumption.

HR = heart rate; VO₂ = oxygen consumption.

HR = heart rate; VO₂ = oxygen consumption.

HR = heart rate; VO₂ = oxygen consumption.

HR = heart rate; VO₂ = oxygen consumption.

HR = heart rate; VO₂ = oxygen consumption.

HR = heart rate; VO₂ = oxygen consumption.

HR = heart rate; VO₂ = oxygen consumption.

HR = heart rate; VO₂ = oxygen consumption.

HR = heart rate; VO₂ = oxygen consumption.

HR = heart rate; VO₂ = oxygen consumption.

HR = heart rate; VO₂ = oxygen consumption.

HR = heart rate; VO₂ = oxygen consumption.

HR = heart rate; VO₂ = oxygen consumption.

HR = heart rate; VO₂ = oxygen consumption.

HR = heart rate; VO₂ = oxygen consumption.

HR = heart rate; VO₂ = oxygen consumption.

HR = heart rate; VO₂ = oxygen consumption.

HR = heart rate; VO₂ = oxygen consumption.

HR = heart rate; VO₂ = oxygen consumption.

HR = heart rate; VO₂ = oxygen consumption.

HR = heart rate; VO₂ = oxygen consumption.

HR = heart rate; VO₂ = oxygen consumption.

HR = heart rate; VO₂ = oxygen consumption.

HR = heart rate; VO₂ = oxygen consumption.

HR = heart rate; VO₂ = oxygen consumption.

HR = heart rate; VO₂ = oxygen consumption.

HR = heart rate; VO₂ = oxygen consumption.

HR = heart rate; VO₂ = oxygen consumption.

HR = heart rate; VO₂ = oxygen consumption.

HR = heart rate; VO₂ = oxygen consumption.

HR = heart rate; VO₂ = oxygen consumption.

HR = heart rate; VO₂ = oxygen consumption.

HR = heart rate; VO₂ = oxygen consumption.

HR = heart rate; VO₂ = oxygen consumption.

HR = heart rate; VO₂ = oxygen consumption.

HR = heart rate; VO₂ = oxygen consumption.

HR = heart rate; VO₂ = oxygen consumption.

HR = heart rate; VO₂ = oxygen consumption.

HR = heart rate; VO₂ = oxygen consumption.

HR = heart rate; VO₂ = oxygen consumption.

HR = heart rate; VO₂ = oxygen consumption.

HR = heart rate; VO₂ = oxygen consumption.

HR = heart rate; VO₂ = oxygen consumption.

HR = heart rate; VO₂ = oxygen consumption.

- requirements to the Subcontract due to the lack of details, sizes, components or any information required for complete and fully operations system will not be accepted.
16. This Prime Contractor shall be responsible to any and all cost necessary for the complete repair of any damages to the existing structures or elements scheduled to remain that my result from the Work.
 17. This Prime Contractor shall abide by the Project Labor Agreement dated 12.21.18
 18. This Prime Contractor shall provide all temporary power necessary to complete the scope of work.
 19. This Prime Contractor shall provide all dumpsters and temporary bathrooms for the duration of this scope.
 20. This Prime Contractor shall provide a schedule utilizing P6 scheduling software – refer to project manual for requirements.
 21. This Prime Contractor shall provide all site and utility removals as indicated and required to perform this scope of work.
 22. This Prime Contractor shall provide excavation and backfill operations for Pedestrian Bridge, Parking Garage Access Bridge site, foundations, gas, electrical, storm, water, fire protection, plumbing, etc associated with each.
 23. This Prime Contractor shall provide deep foundations (h-piles) and foundations systems for Pedestrian Bridge and Access Bridge.
 24. This Prime Contractor shall provide waterproofing of foundations, elevator pit and 'over rooms below'.
 25. This Prime Contractor shall provide precast concrete for the Access Bridge as indicated.
 26. This Prime Contractor shall provide spray on fireproofing of structural and miscellaneous steel.
 27. This Prime Contractor shall provide all miscellaneous steel for the Pedestrian Bridge, Parking Garage and Access Bridge. Miscellaneous steel shall be but not limited to lintels, channels, roof frames, grates, bollards, railings, ~~elevator pit ladders~~, ships ladders, bollards, divider beams, pipe protection, snow gate, etc.
 28. This Prime Contractor shall coordinate with Contract 989-PC (Unistress) and Contract 989-SF (LeChase Construction) ~~the location elevator sump pit, precast embeds and sleeves. This Prime Contractor shall provide the location and size of the elevator pit, elevator rail embeds and~~ structural steel embeds for Stair Tower 1, 2 and 3 no later than March 27, 2019. Failure to meet this date will delay the precast erection.
 29. This Prime Contractor shall provide expedited submittals for all elevators and parking garage stair tower 1, 2 and 3 steel as indicated above.
 30. This Prime Contractor shall remove temporary barricades provided by others.
 31. This Prime Contractor shall provide for the precast caps on ground level of parking structure, concrete masonry units within the parking garage and pedestrian bridge and brick and precast on the pedestrian bridge columns. → CREW NEGOTIATED w/ LeChase \$11,960.00
 32. This Prime Contractor shall provide selective demolition within the vestibule and patch as required to make a seamless transition from vestibule to Pedestrian Bridge
 33. This Prime Contractor shall provide all hollow metal or aluminum doors, frames and associated hardware and glazing.
 34. This Prime Contractor shall provide all aluminum store fronts and glazing within the Pedestrian Bridge and Parking Garage.
 35. This Prime Contractor shall provide all concrete washes, slabs on grade or deck, curbs/islands, equipment pads, etc as indicated.
 36. This Prime Contractor shall caulk between all dissimilar materials (ie masonry to precast, precast to aluminum, masonry to hollow metal, etc) Caulking of precast members to precast members shall be by Unistress (Contract 989-PC)
 37. This Prime Contractor shall provide all ceiling, wall, ceiling, metal wall panels and slab expansion joints. This Prime Contractor shall coordinate with Unistress the size of the expansion joints in the precast concrete slabs.
 38. This Prime Contractor shall provide ~~elevator hoist beams~~, roof framing for ramps and canopies shall furnish (only) the steel for the stair towers. This Prime Contractor shall coordinate the deliveries of steel for the Stair Towers with Contract 989-PC for their installation.
 39. This Prime Contractor shall install the elevator hoist beam in the Pedestrian Bridge provided by Contract 989-EL and elevator ships ladders in Pedestrian Bridge and Parking Garage.
 40. This Prime Contractor shall unload and distribute elevator equipment for Contract 989-PC and discard all elevator waste.

AGENDA ITEM NO. 12

**Authorize CEO to Issue Safety Directives to Ground
Transportation Providers at the Airport
Due to Covid-19**

AGENDA ITEM NO: 12
MEETING DATE: June 8, 2020

ALBANY COUNTY AIRPORT AUTHORITY
REQUEST FOR AUTHORIZATION

ACAA Approved
06/08/2020

DEPARTMENT:

Contact Person: *Philip F. Calderone, Esq., Administration*
Doug Meyers, Public Affairs

PURPOSE OF REQUEST:

Authorize CEO to Issue Safety Directives to Ground Transportation Providers at the Airport Due to Covid-19

BUDGET INFORMATION:

Anticipated in Current Budget: Yes___ No___ NA ✓

FISCAL IMPACT - FUNDING (Dollars or Percentages)

Federal _____ State _____ Airport _____ NA ✓

JUSTIFICATION:

The Authority is requested to adopt the Special Rule below so that the CEO can issue safety directives to ground transportation companies in the quickly changing environment relative to Covid-19.

***SPECIAL RULE RELATED TO GROUND TRANSPORTATION SAFETY DIRECTIVES
Due to COVID-19***

Due to the Covid-19 health epidemic, the Albany County Airport Authority hereby authorizes its Chief Executive Officer to issue directives relative to the operation of ground transportation businesses (Taxicabs, Transportation Network Companies, shuttles and limousines) at the Airport to ensure safety. These directives may include, but not be limited to the wearing of personal protection equipment by vehicle operators and passengers, limitation on shared rides and numbers of passengers, and disinfection of vehicles.

CHIEF EXECUTIVE OFFICER'S RECOMMENDATION:

Recommend approval.

FINAL AGREEMENT SUBJECT TO APPROVAL BY COUNSEL: YES ✓ NA _____

PROCUREMENT DEPARTMENT APPROVAL:

Procurement complies with Authority Procurement Guidelines and Chief Financial Officer has approved. Yes___ NA ✓

AGENDA ITEM NO. 13.1

**Federal/State Grant: Acceptance of
Federal Airport Improvement Program
Grant #3-36-0001-141-2020;
Prepare Airport Master Plan**

AGENDA ITEM NO: 13.1
MEETING DATE: June 8, 2020

ALBANY COUNTY AIRPORT AUTHORITY
REQUEST FOR AUTHORIZATION

ACAA Approved
06/08/2020

DEPARTMENT: *Planning and Engineering*

Contact Person: *Stephen Iachetta, AICP, Airport Planner*

PURPOSE OF REQUEST:

Federal/State Grant: *Acceptance of Federal Airport Improvement Program Grant #3-36-0001-141-2020; Prepare Airport Master Plan*

CONTRACT AMOUNT: Funding Share Allocations

\$ 676,039	<i>Federal Aviation Administration (90%)</i>
0	<i>State and ACAA</i>
<u>75,116</u>	<i>Federal CARES Act (10%)</i>
\$ 751,155	<i>Total</i>

BUDGET INFORMATION:

Anticipated in Current Capital Plan: Yes ✓ No NA
Funding Account No: CPN 2245

FISCAL IMPACT - FUNDING (Dollars or Percentages)

Federal 90% State 0% CARES Act 10%
Funding Source: *Airport Improvement Program*;
Term of Funding: *August 2020 through 2022*
Grant No.: *3-36-0001-141-2020; State PIN -NA*

JUSTIFICATION:

Authorization is requested to accept Airport Improvement Program grant 3-36-0001-141-2020 to establish funding in the 90% Federal Aviation Administration and 10% CARES Act share allocations noted above with a total budget of \$751,155 to support Contract S-1042 with CHA Consulting Inc.. Conformance with applicable Federal regulatory requirements has been reviewed and confirmed with the Federal Aviation Administration to assure ongoing AIP program compliance.

CHIEF EXECUTIVE OFFICER'S RECOMMENDATION:

Recommend approval.

AGENDA ITEM NO: 13.1
MEETING DATE: June 8, 2020

FINAL AGREEMENT SUBJECT TO APPROVAL BY COUNSEL: YES NA

PROCUREMENT DEPARTMENT APPROVAL:

Procurement complies with Authority Procurement Guidelines and Chief Financial Officer has approved. YES NA

BACK-UP MATERIAL:

Please refer to the attached FAA Grant Application.



ALBANY COUNTY AIRPORT AUTHORITY
ALBANY INTERNATIONAL AIRPORT
ADMINISTRATION BUILDING
SUITE 200
ALBANY, NEW YORK 12211-1057

TEL: 518.242.2222
ADMIN FAX: 518.242.2641
FINANCE FAX: 518.242.2640
SITE: www.albanyairport.com

June 4, 2020

Ms. Evelyn Martinez, Manager
New York Airports District Office
One Aviation Plaza, Suite 111
Jamaica, New York 11434

Attention: Ralph Gatto, Airport Engineer

**RE: Airport Improvement Project Application and Request for Grant Issuance;
AIP No. 3-36-0001-141-2020; Prepare Airport Master Plan**

Dear Ms. Martinez,

I am writing to respectfully request your review and concurrence for issuance of the above referenced Airport Improvement Program grant offer to support a passenger/cargo entitlement allocation of \$676,039 as the ninety percent Federal share AIP grant basis as programmed among our respective staff. Enclosed please find one original signed copy of the executed final application package pursuant to the current Airport Sponsors Guide.

Please note that the NEPA Environmental Categorical Exclusion (FONSI-ROD), 7460-1 air space review and Airport Layout Plan Review is not applicable for this project.

Thank you for your ongoing cooperation and assistance with this important airport safety and capacity improvement project at Albany International Airport. Please do not hesitate to call Airport Planner, Steve Iachetta of my staff at (518) 242-2238 if you require any additional information.

Sincerely,

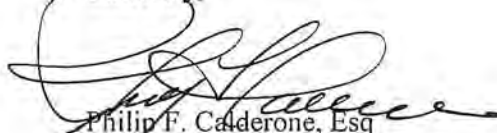

Philip F. Calderone, Esq.
Chief Executive Officer

PFC/ela
Enclosure

cc: Lowell Lingo, NYSDOT-MO Aviation Bureau
Michael Zonsius, Chief Finance Officer
John LaClair, Airport Engineer
Steve Iachetta, Airport Planner

Application for Federal Assistance SF-424

* 1. Type of Submission: <input type="checkbox"/> Preapplication <input checked="" type="checkbox"/> Application <input type="checkbox"/> Changed/Corrected Application	* 2. Type of Application: <input checked="" type="checkbox"/> New <input type="checkbox"/> Continuation <input type="checkbox"/> Revision	* If Revision, select appropriate letter(s): _____ * Other (Specify): _____
---	---	--

* 3. Date Received: 06/04/2020	4. Applicant Identifier: ALB
--	--

5a. Federal Entity Identifier: 3-36-0001-141-2020	5b. Federal Award Identifier: _____
---	---

State Use Only:

6. Date Received by State: _____	7. State Application Identifier: _____
---	---

8. APPLICANT INFORMATION:

*** a. Legal Name:** Albany County Airport Authority

* b. Employer/Taxpayer Identification Number (EIN/TIN): 14-1768979	* c. Organizational DUNS: 1457016990000
--	---

d. Address:

* Street1:	737 Albany Shaker Road
Street2:	Authority Administration Bldg; 2nd Floor
* City:	Albany
County/Parish:	Albany
* State:	NY: New York
Province:	_____
* Country:	USA: UNITED STATES
* Zip / Postal Code:	12211-1057

e. Organizational Unit:

Department Name: Executive	Division Name: _____
--------------------------------------	--------------------------------

f. Name and contact information of person to be contacted on matters involving this application:

Prefix: _____	* First Name: Philip
Middle Name: F.	_____
* Last Name: Calderone	_____
Suffix: Esq.	_____

Title: Chief Executive Officer

Organizational Affiliation:
Albany County Airport Authority

* Telephone Number: 518-242-2222	Fax Number: 518-242-2641
---	---------------------------------

*** Email:** PCalderone@albanyairport.com

Application for Federal Assistance SF-424

*** 9. Type of Applicant 1: Select Applicant Type:**

B: County Government

Type of Applicant 2: Select Applicant Type:

Type of Applicant 3: Select Applicant Type:

* Other (specify):

*** 10. Name of Federal Agency:**

Federal Aviation Administration

11. Catalog of Federal Domestic Assistance Number:

20.106

CFDA Title:

*** 12. Funding Opportunity Number:**

NA

* Title:

NA

13. Competition Identification Number:

NA

Title:

NA

14. Areas Affected by Project (Cities, Counties, States, etc.):

Add Attachment

Delete Attachment

View Attachment

*** 15. Descriptive Title of Applicant's Project:**

Prepare Airport Master Plan

Attach supporting documents as specified in agency instructions.

Add Attachments

Delete Attachments

View Attachments

Application for Federal Assistance SF-424

16. Congressional Districts Of:

* a. Applicant

* b. Program/Project

Attach an additional list of Program/Project Congressional Districts if needed.

17. Proposed Project:

* a. Start Date:

* b. End Date:

18. Estimated Funding (\$):

* a. Federal	<input type="text" value="676,039.00"/>
* b. Applicant	<input type="text" value="0.00"/>
* c. State	<input type="text" value="0.00"/>
* d. Local	<input type="text" value="0.00"/>
* e. Other	<input type="text" value="75,116.00"/>
* f. Program Income	<input type="text" value="0.00"/>
* g. TOTAL	<input type="text" value="751,155.00"/>

* 19. Is Application Subject to Review By State Under Executive Order 12372 Process?

- a. This application was made available to the State under the Executive Order 12372 Process for review on
- b. Program is subject to E.O. 12372 but has not been selected by the State for review.
- c. Program is not covered by E.O. 12372.

* 20. Is the Applicant Delinquent On Any Federal Debt? (If "Yes," provide explanation in attachment.)

Yes No

If "Yes", provide explanation and attach

21. *By signing this application, I certify (1) to the statements contained in the list of certifications** and (2) that the statements herein are true, complete and accurate to the best of my knowledge. I also provide the required assurances** and agree to comply with any resulting terms if I accept an award. I am aware that any false, fictitious, or fraudulent statements or claims may subject me to criminal, civil, or administrative penalties. (U.S. Code, Title 218, Section 1001)

** I AGREE

** The list of certifications and assurances, or an internet site where you may obtain this list, is contained in the announcement or agency specific instructions.

Authorized Representative:

Prefix: * First Name:
Middle Name:
* Last Name:
Suffix:

* Title:

* Telephone Number: Fax Number:

* Email:

* Signature of Authorized Representative: 

* Date Signed:

Application for Federal Assistance (Development and Equipment Projects)

PART II – PROJECT APPROVAL INFORMATION

Part II - SECTION A	
The term "Sponsor" refers to the applicant name provided in box 8 of the associated SF-424 form.	
Item 1. Does Sponsor maintain an active registration in the System for Award Management (www.SAM.gov)?	<input checked="" type="checkbox"/> Yes <input type="checkbox"/> No
Item 2. Can Sponsor commence the work identified in the application in the fiscal year the grant is made or within six months after the grant is made, whichever is later?	<input checked="" type="checkbox"/> Yes <input type="checkbox"/> No <input type="checkbox"/> N/A
Item 3. Are there any foreseeable events that would delay completion of the project? If yes, provide attachment to this form that lists the events.	<input type="checkbox"/> Yes <input checked="" type="checkbox"/> No <input type="checkbox"/> N/A
Item 4. Will the project(s) covered by this request have impacts or effects on the environment that require mitigating measures? If yes, attach a summary listing of mitigating measures to this application and identify the name and date of the environmental document(s).	<input type="checkbox"/> Yes <input checked="" type="checkbox"/> No <input type="checkbox"/> N/A
Item 5. Is the project covered by this request included in an approved Passenger Facility Charge (PFC) application or other Federal assistance program? If yes, please identify other funding sources by checking all applicable boxes.	<input type="checkbox"/> Yes <input checked="" type="checkbox"/> No <input type="checkbox"/> N/A
<input type="checkbox"/> The project is included in an <i>approved</i> PFC application. If included in an approved PFC application, does the application <i>only</i> address AIP matching share? <input type="checkbox"/> Yes <input type="checkbox"/> No	
<input type="checkbox"/> The project is included in another Federal Assistance program. Its CFDA number is below.	
Item 6. Will the requested Federal assistance include Sponsor indirect costs as described in 2 CFR Appendix VII to Part 200, States and Local Government and Indian Tribe Indirect Cost Proposals?	<input type="checkbox"/> Yes <input checked="" type="checkbox"/> No <input type="checkbox"/> N/A
If the request for Federal assistance includes a claim for allowable indirect costs, select the applicable indirect cost rate the Sponsor proposes to apply:	
<input type="checkbox"/> De Minimis rate of 10% as permitted by 2 CFR § 200.414.	
<input type="checkbox"/> Negotiated Rate equal to _____ % as approved by _____ (the Cognizant Agency) on _____ (Date) (2 CFR part 200, appendix VII).	
<i>Note: Refer to the instructions for limitations of application associated with claiming Sponsor indirect costs.</i>	

PART II - SECTION B

Certification Regarding Lobbying

The declarations made on this page are under the signature of the authorized representative as identified in box 21 of form SF-424, to which this form is attached. The term "Sponsor" refers to the applicant name provided in box 8 of the associated SF-424 form.

The Authorized Representative certifies, to the best of his or her knowledge and belief, that:

(1) No Federal appropriated funds have been paid or will be paid, by or on behalf of the Sponsor, to any person for influencing or attempting to influence an officer or employee of an agency, a Member of Congress, an officer or employee of Congress, or an employee of a Member of Congress in connection with the awarding of any Federal contract, the making of any Federal grant, the making of any Federal loan, the entering into of any cooperative agreement, and the extension, continuation, renewal, amendment, or modification of any Federal contract, grant, loan, or cooperative agreement.

(2) If any funds other than Federal appropriated funds have been paid or will be paid to any person for influencing or attempting to influence an officer or employee of any agency, a Member of Congress, an officer or employee of Congress, or an employee of a Member of Congress in connection with this Federal contract, grant, loan, or cooperative agreement, the Authorized Representative shall complete and submit Standard Form-LLL, "Disclosure Form to Report Lobbying," in accordance with its instructions.

(3) The Authorized Representative shall require that the language of this certification be included in the award documents for all sub-awards at all tiers (including subcontracts, subgrants, and contracts under grants, loans, and cooperative agreements) and that all subrecipients shall certify and disclose accordingly.

This certification is a material representation of fact upon which reliance was placed when this transaction was made or entered into. Submission of this certification is a prerequisite for making or entering into this transaction imposed by section 1352, title 31, U.S. Code. Any person who fails to file the required certification shall be subject to a civil penalty of not less than \$10,000 and not more than \$100,000 for each such failure.

PART II – SECTION C

The Sponsor hereby represents and certifies as follows:

1. Compatible Land Use – The Sponsor has taken the following actions to assure compatible usage of land adjacent to or in the vicinity of the airport:

ALB Airport is situated in the center of the Town of Colonie and the Town Comprehensive Plan includes an Airport Noise Compatibility Zone, Airport Business District and appropriate local land-use regulations to assure ongoing Airport land use compatibility.

2. Defaults – The Sponsor is not in default on any obligation to the United States or any agency of the United States Government relative to the development, operation, or maintenance of any airport, except as stated herewith:

Confirmed.

3. Possible Disabilities – There are no facts or circumstances (including the existence of effective or proposed leases, use agreements or other legal instruments affecting use of the Airport or the existence of pending litigation or other legal proceedings) which in reasonable probability might make it impossible for the Sponsor to carry out and complete the Project or carry out the provisions of the Grant Assurances, either by limiting its legal or financial ability or otherwise, except as follows:

Confirmed.

4. Consistency with Local Plans – The project is reasonably consistent with plans existing at the time of submission of this application) of public agencies that are authorized by the State in which the project is located to plan for the development of the area surrounding the airport.

Confirmed.

5. Consideration of Local Interest – It has given fair consideration to the interest of communities in or near where the project may be located.

Confirmed.

6. Consultation with Users – In making a decision to undertake an airport development project under Title 49, United States Code, it has consulted with airport users that will potentially be affected by the project (§ 47105(a)(2)).

Confirmed.

7. Public Hearings – In projects involving the location of an airport, an airport runway or a major runway extension, it has afforded the opportunity for public hearings for the purpose of considering the economic, social, and environmental effects of the airport or runway location and its consistency with goals and objectives of such planning as has been carried out by the community and it shall, when requested by the Secretary, submit a copy of the transcript of such hearings to the Secretary. Further, for such projects, it has on its management board either voting representation from the communities where the project is located or has advised the communities that they have the right to petition the Secretary concerning a proposed project.

Not applicable.

8. Air and Water Quality Standards – In projects involving airport location, a major runway extension, or runway location it will provide for the Governor of the state in which the project is located to certify in writing to the Secretary that the project will be located, designed, constructed, and operated so as to comply with applicable and air and water quality standards. In any case where such standards have not been approved and where applicable air and water quality standards have been promulgated by the Administrator of the Environmental Protection Agency, certification shall be obtained from such Administrator. Notice of certification or refusal to certify shall be provided within sixty days after the project application has been received by the Secretary.

Not applicable.

PART II – SECTION C (Continued)

9. Exclusive Rights – There is no grant of an exclusive right for the conduct of any aeronautical activity at any airport owned or controlled by the Sponsor except as follows:

Confirmed.

10. Land – (a) The sponsor holds the following property interest in the following areas of land, which are to be developed or used as part of or in connection with the Airport subject to the following exceptions, encumbrances, and adverse interests, all of which areas are identified on the aforementioned property map designated as Exhibit "A". [1]

Confirmed.

The Sponsor further certifies that the above is based on a title examination by a qualified attorney or title company and that such attorney or title company has determined that the Sponsor holds the above property interests.

(b) The Sponsor will acquire within a reasonable time, but in any event prior to the start of any construction work under the Project, the following property interest in the following areas of land on which such construction work is to be performed, all of which areas are identified on the aforementioned property map designated as Exhibit "A". [1]

Confirmed.

(c) The Sponsor will acquire within a reasonable time, and if feasible prior to the completion of all construction work under the Project, the following property interest in the following areas of land which are to be developed or used as part of or in connection with the Airport as it will be upon completion of the Project, all of which areas are identified on the aforementioned property map designated as Exhibit "A". [1]

Not applicable.

¹ State the character of property interest in each area and list and identify for each all exceptions, encumbrances, and adverse interests of every kind and nature, including liens, easements, leases, etc. The separate areas of land need only be identified here by the area numbers shown on the property map.

PART III – BUDGET INFORMATION – CONSTRUCTION

SECTION A – GENERAL	
1. Federal Domestic Assistance Catalog Number:	20-106 Airport Improvement Program
2. Functional or Other Breakout:	3-36-0001-141-2020

SECTION B – CALCULATION OF FEDERAL GRANT			
Cost Classification	Latest Approved Amount (Use only for revisions)	Adjustment + or (-) Amount (Use only for revisions)	Total Amount Required
1. Administration expense			
2. Preliminary expense	1,190		1,190
3. Land, structures, right-of-way			
4. Architectural engineering basic fees	749,965		749,965
5. Other Architectural engineering fees			
6. Project inspection fees			
7. Land development			
8. Relocation Expenses			
9. Relocation payments to Individuals and Businesses			
10. Demolition and removal			
11. Construction and project improvement			
12. Equipment			
13. Miscellaneous			
14. Subtotal (Lines 1 through 13)			
15. Estimated Income (if applicable)			
16. Net Project Amount (Line 14 minus 15)			
17. Less: Ineligible Exclusions (Section C, line 23 g.)			
18. Subtotal (Lines 16 through 17)	\$ 751,155		\$ 751,155
19. Federal Share requested of Line 18	676,039		676,039
20. Grantee share			
21. Other shares	75,116		75,116
22. TOTAL PROJECT (Lines 19, 20 & 21)	\$ 751,155		\$ 751,155

SECTION C – EXCLUSIONS	
23. Classification (Description of non-participating work)	Amount Ineligible for Participation
a.	
b.	
c.	
d.	
e.	
f.	
g. Total	

SECTION D – PROPOSED METHOD OF FINANCING NON-FEDERAL SHARE	
24. Grantee Share – Fund Categories	Amount
a. Securities	
b. Mortgages	
c. Appropriations (by Applicant)	
d. Bonds	
e. Tax Levies	
f. Non-Cash	
g. Other (Explain):	
h. TOTAL - Grantee share	
25. Other Shares	Amount
a. State	
b. Other	
c. TOTAL - Other Shares	\$ 75,116
26. TOTAL NON-FEDERAL FINANCING	

SECTION E – REMARKS (Attach sheets if additional space is required)
<p>AIP Entitlement comprises 90% and CARES Act comprises 10% of the as-bid program budget.</p>

PART IV – PROGRAM NARRATIVE
(Suggested Format)

PROJECT: 3-36-0001-141-2020 Prepapre Airport Master Plan Study
AIRPORT: ALB- Albany International Airport
1. Objective: The ALB Airport Master Plan was last updated over 20-years ago. Over this period, the Authority has added over 400-acres of land and has improved aeronautical facilities significantly. In 2020, the Authority completed a \$60-million modernization plan which includes a 1,000 parking garage and a host of Terminal improvements. The proposed Master Plan Study is proposed to address recent improvements and establish the framework necessary to preserve and enhance aeronautical facilities through 2040 in conformance with FAA Advisory Circulars 150/5070-6B (Change 2), Airport Design 150/5300-18 and S.O.P. 2.00 and 3.00 for the Airport Layout Plan documents.
2. Benefits Anticipated: The Master Plan will guide aeronautical improvements through 2040 and support maintaining a safe, efficient, financially sound and sustainable airport for the Albany County Airport Authority.
3. Approach: (See approved Scope of Work in Final Application)
4. Geographic Location: ALB currently comprises 1,165 acres under ACAA jurisdiction as of April 2020 not including avigation easement areas.
5. If Applicable, Provide Additional Information:
6. Sponsor's Representative: (include address & telephone number) Philip F. Calderone, Esq.; Chief Executive Officer; Albany County Airpor Authority; Adminsitration Bldg.; 737 Albany Shaker Road; Albany, NY 12211-1057; Telephone 518-242-2222



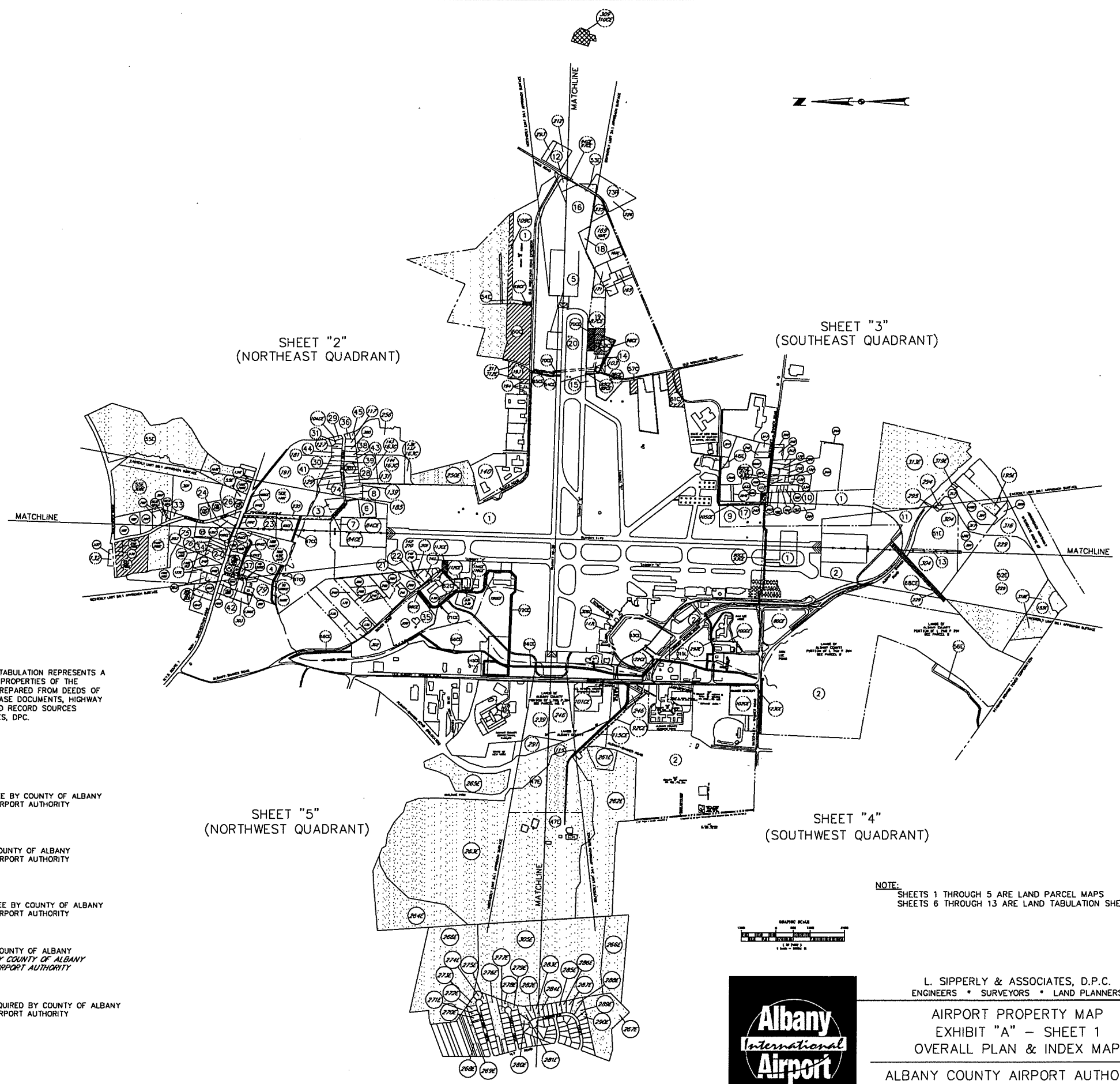

DATE
DRAWN BY
CHECKED BY
ESTIMATED BY
DESIGNED BY



NOTE:

THIS MAP AND LAND INVENTORY DEED TABULATION REPRESENTS A COMPILATION OF LANDS, PARCELS AND PROPERTIES OF THE ALBANY COUNTY AIRPORT AUTHORITY PREPARED FROM DEEDS OF RECORD, LAND SURVEY MAPS, LAND LEASE DOCUMENTS, HIGHWAY RIGHT-OF-WAY MAPS, AND OTHER LAND RECORD SOURCES PROVIDED TO L. SIPPERLY & ASSOCIATES, D.P.C.

LEGEND:

-  PROPERTIES ACQUIRED IN FEE BY COUNTY OF ALBANY AND/OR ALBANY COUNTY AIRPORT AUTHORITY
-  EASEMENTS ACQUIRED BY COUNTY OF ALBANY AND/OR ALBANY COUNTY AIRPORT AUTHORITY
-  PROPERTIES CONVEYED IN FEE BY COUNTY OF ALBANY AND/OR ALBANY COUNTY AIRPORT AUTHORITY
-  EASEMENTS CONVEYED BY COUNTY OF ALBANY OR ON PROPERTY OWNED BY COUNTY OF ALBANY AND/OR ALBANY COUNTY AIRPORT AUTHORITY
-  RESTRICTIVE COVENANTS ACQUIRED BY COUNTY OF ALBANY AND/OR ALBANY COUNTY AIRPORT AUTHORITY

NOTE:

SHEETS 1 THROUGH 5 ARE LAND PARCEL MAPS
SHEETS 6 THROUGH 13 ARE LAND TABULATION SHEETS



L. SIPPERLY & ASSOCIATES, D.P.C.
ENGINEERS • SURVEYORS • LAND PLANNERS

AIRPORT PROPERTY MAP
EXHIBIT "A" - SHEET 1
OVERALL PLAN & INDEX MAP
ALBANY COUNTY AIRPORT AUTHORITY
ALBANY, NEW YORK

LAST REVISED: 1/31/19

CHECKED BY: [blank] DATE: [blank]
 CHECKED BY: [blank] DATE: [blank]
 CHECKED BY: [blank] DATE: [blank]
 CHECKED BY: [blank] DATE: [blank]

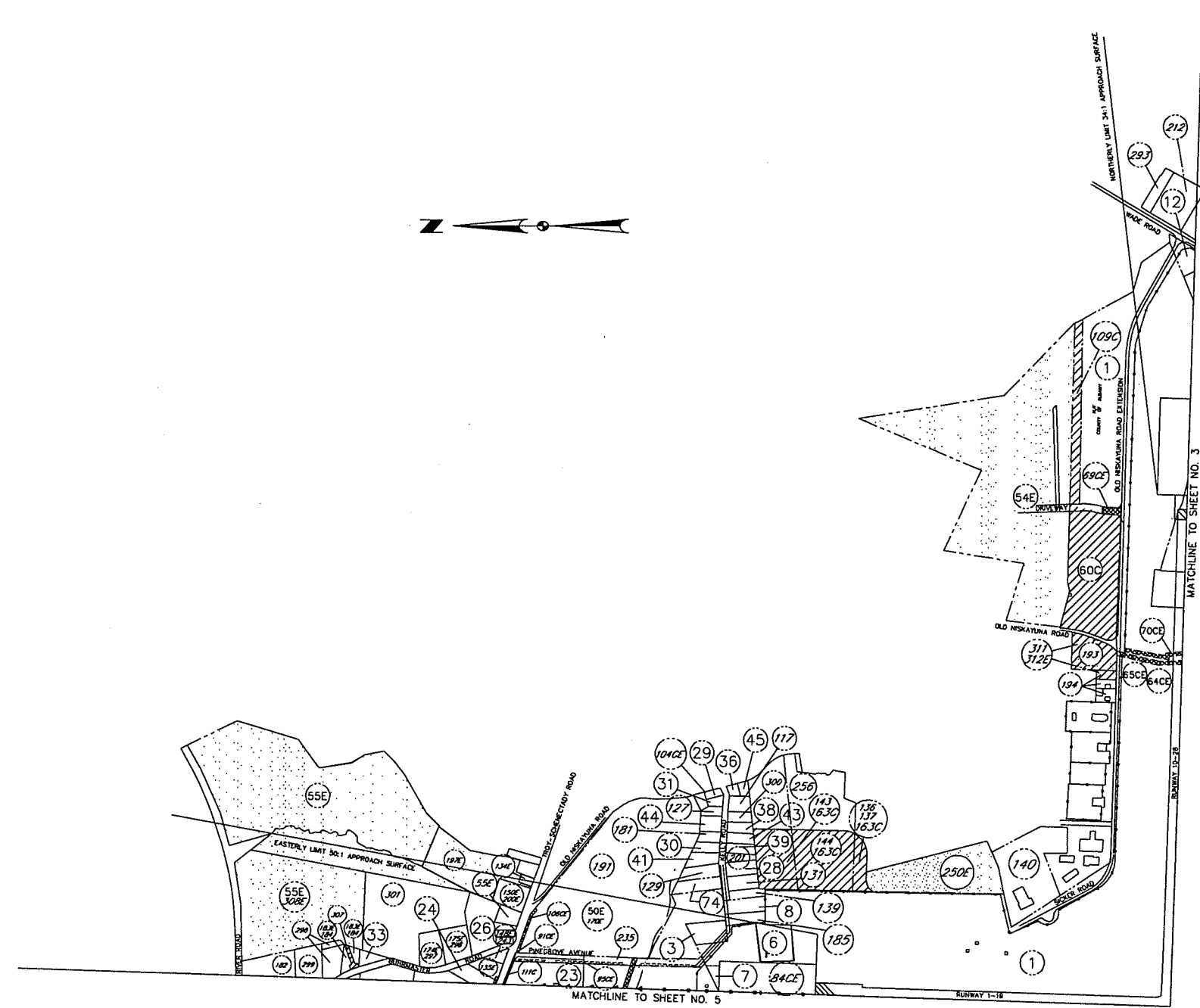
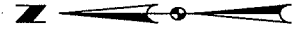

LEGEND:

- PROPERTIES ACQUIRED IN FEE BY COUNTY OF ALBANY AND/OR ALBANY COUNTY AIRPORT AUTHORITY
- EASEMENTS ACQUIRED BY COUNTY OF ALBANY AND/OR ALBANY COUNTY AIRPORT AUTHORITY
- PROPERTIES CONVEYED IN FEE BY COUNTY OF ALBANY AND/OR ALBANY COUNTY AIRPORT AUTHORITY
- EASEMENTS CONVEYED BY COUNTY OF ALBANY OR ON PROPERTY OWNED BY COUNTY OF ALBANY AND/OR ALBANY COUNTY AIRPORT AUTHORITY
- RESTRICTIVE COVENANTS ACQUIRED BY COUNTY OF ALBANY AND/OR ALBANY COUNTY AIRPORT AUTHORITY

NOTE:

THIS MAP AND LAND INVENTORY DEED TABULATION REPRESENTS A COMPILATION OF LANDS, PARCELS AND PROPERTIES OF THE ALBANY COUNTY AIRPORT AUTHORITY PREPARED FROM DEEDS OF RECORD, LAND SURVEY MAPS, LAND LEASE DOCUMENTS, HIGHWAY RIGHT-OF-WAY MAPS, AND OTHER LAND RECORD SOURCES PROVIDED TO L. SIPPERLY & ASSOCIATES, D.P.C.



L. SIPPERLY & ASSOCIATES, D.P.C.
 ENGINEERS • SURVEYORS • LAND PLANNERS

AIRPORT PROPERTY MAP
 EXHIBIT "A" - SHEET 2
 NORTHEAST QUADRANT

ALBANY COUNTY AIRPORT AUTHORITY
 ALBANY, NEW YORK



LAST REVISED: 1/31/19

DRAWN BY: [Name] DATE: [Date]
 CHECKED BY: [Name] DATE: [Date]
 ESTIMATED BY: [Name] DATE: [Date]

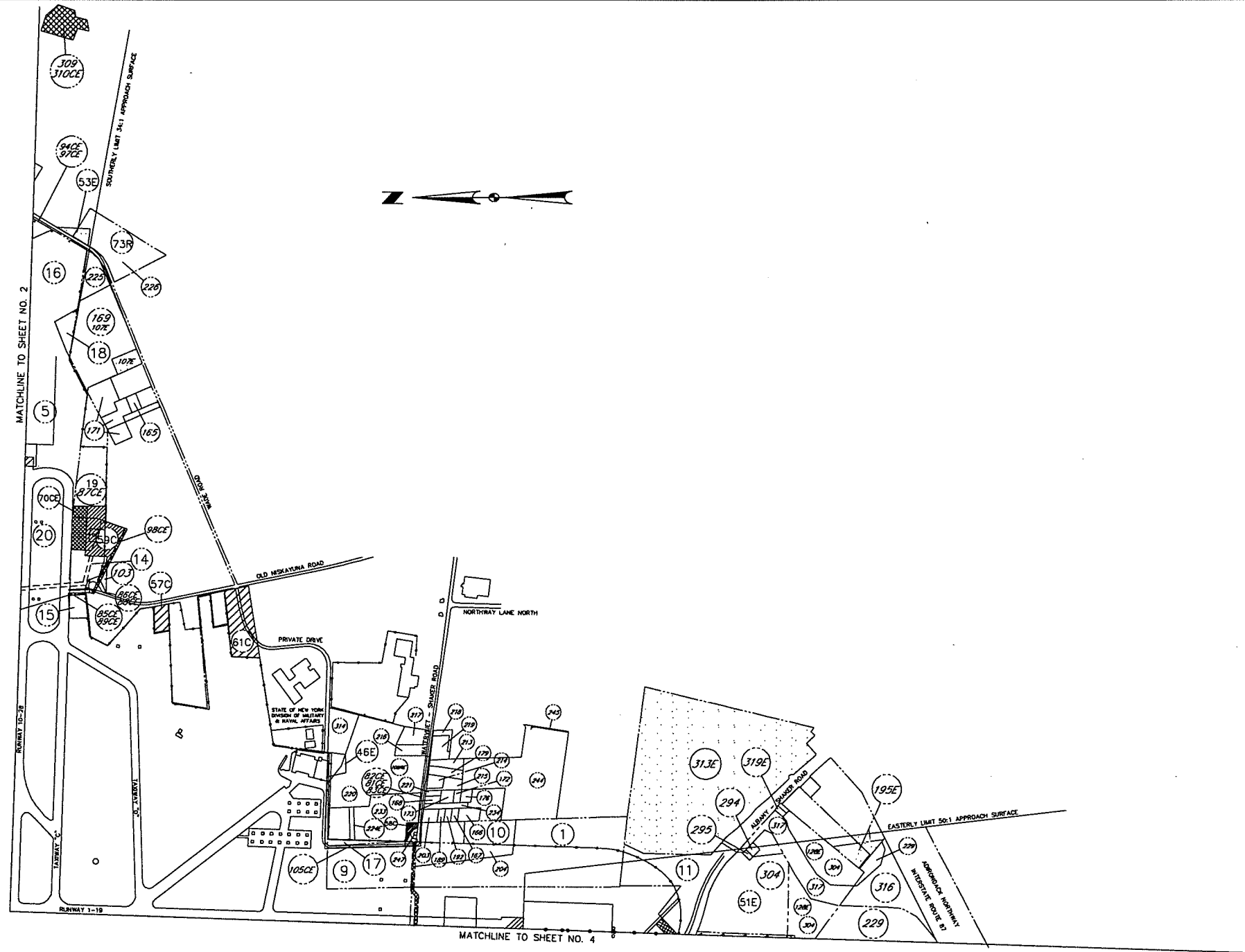

LEGEND:

- PROPERTIES ACQUIRED IN FEE BY COUNTY OF ALBANY AND/OR ALBANY COUNTY AIRPORT AUTHORITY
- EASEMENTS ACQUIRED BY COUNTY OF ALBANY AND/OR ALBANY COUNTY AIRPORT AUTHORITY
- PROPERTIES CONVEYED IN FEE BY COUNTY OF ALBANY AND/OR ALBANY COUNTY AIRPORT AUTHORITY
- EASEMENTS CONVEYED BY COUNTY OF ALBANY OR ON PROPERTY OWNED BY COUNTY OF ALBANY AND/OR ALBANY COUNTY AIRPORT AUTHORITY
- RESTRICTIVE COVENANTS ACQUIRED BY COUNTY OF ALBANY AND/OR ALBANY COUNTY AIRPORT AUTHORITY

NOTE:

THIS MAP AND LAND INVENTORY DEED TABULATION REPRESENTS A COMPILATION OF LANDS, PARCELS AND PROPERTIES OF THE ALBANY COUNTY AIRPORT AUTHORITY PREPARED FROM DEEDS OF RECORD, LAND SURVEY MAPS, LAND LEASE DOCUMENTS, HIGHWAY RIGHT-OF-WAY MAPS, AND OTHER LAND RECORD SOURCES PROVIDED TO L. SIPPERLY & ASSOCIATES, D.P.C.



LAST REVISED: 1/31/19



L. SIPPERLY & ASSOCIATES, D.P.C.
 ENGINEERS • SURVEYORS • LAND PLANNERS
AIRPORT PROPERTY MAP
EXHIBIT "A" - SHEET 3
SOUTHEAST QUADRANT
 ALBANY COUNTY AIRPORT AUTHORITY
 ALBANY, NEW YORK

DESIGNED BY: DATE: DRAWN BY: ESTIMATED BY: CHECKED BY:

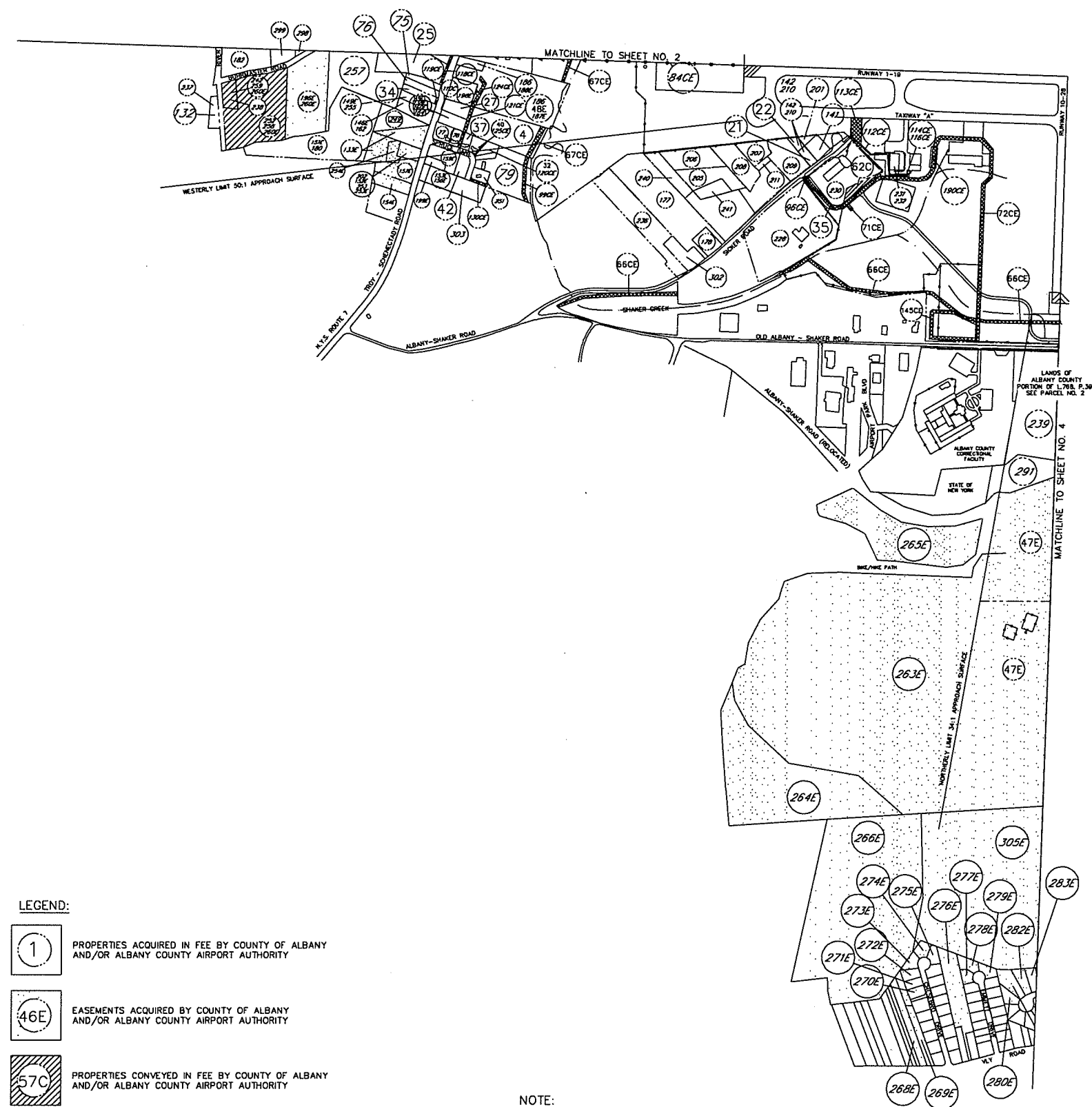

LEGEND:

- 1 PROPERTIES ACQUIRED IN FEE BY COUNTY OF ALBANY AND/OR ALBANY COUNTY AIRPORT AUTHORITY
- 46E EASEMENTS ACQUIRED BY COUNTY OF ALBANY AND/OR ALBANY COUNTY AIRPORT AUTHORITY
- 57C PROPERTIES CONVEYED IN FEE BY COUNTY OF ALBANY AND/OR ALBANY COUNTY AIRPORT AUTHORITY
- 63CE EASEMENTS CONVEYED BY COUNTY OF ALBANY OR ON PROPERTY OWNED BY COUNTY OF ALBANY AND/OR ALBANY COUNTY AIRPORT AUTHORITY
- 73R RESTRICTIVE COVENANTS ACQUIRED BY COUNTY OF ALBANY AND/OR ALBANY COUNTY AIRPORT AUTHORITY

NOTE:

THIS MAP AND LAND INVENTORY DEED TABULATION REPRESENTS A COMPILATION OF LANDS, PARCELS AND PROPERTIES OF THE ALBANY COUNTY AIRPORT AUTHORITY PREPARED FROM DEEDS OF RECORD, LAND SURVEY MAPS, LAND LEASE DOCUMENTS, HIGHWAY RIGHT-OF-WAY MAPS, AND OTHER LAND RECORD SOURCES PROVIDED TO L. SIPPERLY & ASSOCIATES, D.P.C.



LAST REVISED: 1/31/19

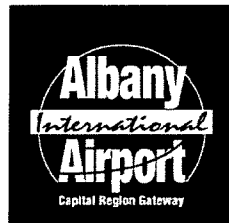

L. SIPPERLY & ASSOCIATES, D.P.C.
ENGINEERS • SURVEYORS • LAND PLANNERS

AIRPORT PROPERTY MAP
EXHIBIT "A" - SHEET 5
NORTHWEST QUADRANT

ALBANY COUNTY AIRPORT AUTHORITY
ALBANY, NEW YORK

PARCEL NO.	GRANTOR	GRANTEE	DEED DATE	RECORDED	AREA (AC.+/-)	REMARKS
1	CITY OF ALBANY	COUNTY OF ALBANY	OCT. 10, 1960	L 1664 P 229	682	PORTION OF SOUTHWEST CORNER OF THIS PARCEL CURRENTLY LEASED TO ENGEL FOR AGRICULTURAL PURPOSES.
2	THOMAS B. BERGAN	COUNTY OF ALBANY	DEC. 22, 1925	L 768 P 394	8.9	PORTION OF DEED
3	PHILIP C. AND MARY A. VEDDER	COUNTY OF ALBANY	FEB. 21, 1961	L 1675 P 473	1.2	
4	JOSEPH C. AND JULE VANWINKLE	COUNTY OF ALBANY	FEB. 27, 1961	L 1676 P 167	4	
5	ROSE, ELIZABETH, ANNA, LOUISE AND THERESA RUFF	COUNTY OF ALBANY	MAR. 1, 1961	L 1676 P 371	18	
6	GRACE GUINAN	COUNTY OF ALBANY	APR. 5, 1961	L 1679 P 211	2	
7	CITY OF ALBANY	COUNTY OF ALBANY	MAY 12, 1961	L 1682 P 421	0.5	
8	DAVID J. AND ROSE A. ROBILLARD	COUNTY OF ALBANY	MAY 23, 1961	L 1683 P 391	0.9	
9	RAYMOND SCHULTZ	COUNTY OF ALBANY	DEC. 14, 1964	L 1816 P 185	7.3	
10	PAUL F. PEETS	COUNTY OF ALBANY	JULY 13, 1966	L 1875 P 183	5.4	
11	E. WALTER ENGEL	COUNTY OF ALBANY	JULY 15, 1966	L 1875 P 237	9.6	PORTION OF THIS PARCEL CURRENTLY LEASED TO ENGEL FOR AGRICULTURAL PURPOSES
12	THEODORE W. AND MARJORIE M. PRINCE	COUNTY OF ALBANY	AUG. 14, 1973	L 2069 P 271	1.3	
13	E. WALTER AND ELIZABETH ENGEL	COUNTY OF ALBANY	SEPT. 6, 1974	L 2087 P 223	1	
14	LOUISA B. HELLWIG	COUNTY OF ALBANY	APR. 10, 1974	L 2079 P 775	3.9	SEE PARCEL NO. 57C
15	JOHN F. A. AND LOUISA B. HELLWIG	COUNTY OF ALBANY	APR. 3, 1975	L 2096 P 155	0.8	SEE PARCEL NO. 64CE
16	COUNCIL COMMERCE CORPORATION	COUNTY OF ALBANY	NOV. 24, 1975	L 2109 P 215	6.2	
17	CONN REALTY CORPORATION	COUNTY OF ALBANY	DEC. 30, 1977	L 2143 P 1061	0.3	LAND SWAP; SEE PARCEL NO. 58C
18	JOHN J. AND ELIZABETH ANN HUBAN	COUNTY OF ALBANY	JUNE 20, 1979	L 2171 P 407	0.6	
19	CATHERINE M. FISH	COUNTY OF ALBANY	FEB. 3, 1980	L 2183 P 309	6.1	
20	TOWN OF COLONIE	COUNTY OF ALBANY	MAR. 18, 1980	L 2185 P 1149	6.8	CORRECTIVE DEED - 2084 / 337
21	ROBERT W., SR. AND CATHERINE S. HACKEL	COUNTY OF ALBANY	MAY 29, 1981	L 2206 P 317	0.3	F. A. A. NOISE ABATEMENT GRANT; FEDERAL PROJ. NO. 6-36-0001-09
22	ROBERT W. HACKEL	COUNTY OF ALBANY	MAY 29, 1981	L 2206 P 319	0.4	F. A. A. NOISE ABATEMENT GRANT; FEDERAL PROJ. NO. 6-36-0001-09
23	HONIGSBAUM'S INC., ET. AL.	COUNTY OF ALBANY	OCT. 1, 1981	L 2195 P 1075	4.7	ACQUIRED BY EMINENT DOMAIN, COURT RECORDS INDEX NO. 8891-81. F. A. A. NOISE ABATEMENT GRANT; FED. PROJ. NO. 6-36-0001-09. ALSO, PREV. AVIGATION EASEMENT L. 1643 P. 481
24	CARDLINE B. KNAPP	COUNTY OF ALBANY	OCT. 7, 1981	L 2213 P 839	1.0	F. A. A. NOISE ABATEMENT GRANT; FEDERAL PROJ. NO. 6-36-0001-09
25	HELMUT L. AND GLORIA SALISBURY SCHMEICHEL	COUNTY OF ALBANY	JULY 14, 1982	L 2225 P 701	4	F. A. A. NOISE ABATEMENT GRANT; FEDERAL PROJ. NO. 6-36-0001-09
26	ESTATE OF IRVING I. BUHRMASTER	COUNTY OF ALBANY	SEPT. 28, 1983	L 2247 P 157	3.5	F. A. A. NOISE ABATEMENT GRANT; FEDERAL PROJ. NO. 6-36-0001-09
27	JULE VAN WINKLE	COUNTY OF ALBANY	MAR. 9, 1984	L 2257 P 479	0.5	F. A. A. NOISE ABATEMENT GRANT; FEDERAL PROJ. NO. 6-36-0001-09
28	W. GLENN AND MARGARET A. BALDWIN	COUNTY OF ALBANY	JAN. 4, 1985	L 2276 P 403	1	F. A. A. NOISE ABATEMENT GRANT; FEDERAL PROJ. NO. 6-36-0001-09
29	MICHAEL J. GERRITY AND OTHERS	COUNTY OF ALBANY	JUNE 28, 1985	L 2294 P 995	0.3	F. A. A. NOISE ABATEMENT GRANT; FEDERAL PROJ. NO. 6-36-0001-04-84
30	MARY BEER	COUNTY OF ALBANY	NOV. 25, 1985	L 2297 P 865	0.4	F. A. A. NOISE ABATEMENT GRANT; FEDERAL PROJ. NO. 6-36-0001-04-84
31	HARRY M. KELLY AND RUTH C. BARBAGALLO	COUNTY OF ALBANY	JAN. 29, 1986	L 2303 P 159	0.3	F. A. A. NOISE ABATEMENT GRANT; FEDERAL PROJ. NO. 6-36-0001-04-84
32	JOHN E. AND THEA M. GRAHAM	COUNTY OF ALBANY	MAR. 5, 1986	L 2305 P 309	0.5	F. A. A. NOISE ABATEMENT GRANT; FEDERAL PROJ. NO. 6-36-0001-04-84
33	FOSTER C. AND DOROTHY A. GOODALE	COUNTY OF ALBANY	APR. 9, 1986	L 2308 P 123	0.5	F. A. A. NOISE ABATEMENT GRANT; FEDERAL PROJ. NO. 6-36-0001-07-85
34	DR. BASAVARAJA DREKONDY	COUNTY OF ALBANY	OCT. 1, 1986	L 2322 P 565	0.4	F. A. A. NOISE ABATEMENT GRANT; FEDERAL PROJ. NO. 6-36-0001-09
35	ALBANY COUNTY IDA AND COMMAND AIRWAYS, INC.	COUNTY OF ALBANY	NOV. 20, 1986	L 2335 P 729	0.7	
36	TIMOTHY FREDERICK	COUNTY OF ALBANY	DEC. 31, 1986	L 2328 P 832	0.1	F. A. A. NOISE ABATEMENT GRANT; FEDERAL PROJ. NO. 6-36-0001-04-84
37	JAMES T. AND LISA A. HOFFMAN	COUNTY OF ALBANY	JUNE 15, 1990	L 2417 P 285	0.3	F. A. A. NOISE ABATEMENT GRANT; FEDERAL PROJ. NO. 6-36-0001-04-84
38	SCOTT A. AND JANET L. McCLOUD	COUNTY OF ALBANY	JULY 17, 1990	L 2419 P 593	0.6	F. A. A. NOISE ABATEMENT GRANT; FEDERAL PROJ. NO. 6-36-0001-04-84
39	HERBERT AND PATRICIA E. LEICHMAN	COUNTY OF ALBANY	SEPT. 20, 1990	L 2423 P 721	0.7	F. A. A. NOISE ABATEMENT GRANT; FEDERAL PROJ. NO. 6-36-0001-09
40	LORENZINA MASTROIANNI	COUNTY OF ALBANY	SEPT. 21, 1990	L 2423 P 855	0.4	F. A. A. NOISE ABATEMENT GRANT; FEDERAL PROJ. NO. 6-36-0001-04-84
41	VIVIAN PAIGE	COUNTY OF ALBANY	OCT. 26, 1990	L 2425 P 1053	0.8	F. A. A. NOISE ABATEMENT GRANT; FEDERAL PROJ. NO. 6-36-0001-09
42	FRANK A. AND DOREEN L. VALCIK	COUNTY OF ALBANY	NOV. 27, 1990	L 2427 P 847	0.5	F. A. A. NOISE ABATEMENT GRANT; FEDERAL PROJ. NO. 6-36-0001-04-84
43	TOH MING LU AND GWO CHING WANG	COUNTY OF ALBANY	NOV. 30, 1990	L 2427 P 1105	0.6	F. A. A. NOISE ABATEMENT GRANT; FEDERAL PROJ. NO. 6-36-0001-04-84
44	DAVID JESMAIN	COUNTY OF ALBANY	DEC. 12, 1990	L 2428 P 845	0.7	F. A. A. NOISE ABATEMENT GRANT; FEDERAL PROJ. NO. 6-36-0001-04-84
45	BOOTH W. AND DALE M. UPTON	COUNTY OF ALBANY	JAN. 25, 1991	L 2431 P 335	0.3	F. A. A. NOISE ABATEMENT GRANT; FEDERAL PROJ. NO. 6-36-0001-04-84

NOTE:

THIS MAP AND LAND INVENTORY DEED TABULATION REPRESENTS A COMPILATION OF LANDS, PARCELS AND PROPERTIES OF THE ALBANY COUNTY AIRPORT AUTHORITY PREPARED FROM DEEDS OF RECORD, LAND SURVEY MAPS, LAND LEASE DOCUMENTS, HIGHWAY RIGHT-OF-WAY MAPS, AND OTHER LAND RECORD SOURCES PROVIDED TO L. SIPPERLY & ASSOCIATES, D.P.C.

L. SIPPERLY & ASSOCIATES, D.P.C.
ENGINEERS • SURVEYORS • LAND PLANNERS



Albany
International
Airport
Capital Region Gateway

AIRPORT PROPERTY MAP
EXHIBIT "A" - SHEET 6
LAND TABULATION

ALBANY COUNTY AIRPORT AUTHORITY
ALBANY, NEW YORK

LAST REVISED: 1/31/19

PARCEL NO.	GRANTOR	GRANTEE	DEED DATE	RECORDED	AREA	REMARKS
46E	HAVELOCK AND LILLIE PRIMETT	CITY OF ALBANY	MAY 1, 1940	L 915 P 416	0.4	CLEARANCE EASEMENT
47E	SHAKER RIDGE COUNTRY CLUB, INC.	CITY OF ALBANY	DEC. 28, 1951	L 1296 P 176	107.5	AVIGATION EASEMENT 33:1 PLANE
48E	VERDDY VOLUNTEER FIRE ASSOCIATION, INC.	CITY OF ALBANY	APR. 4, 1960	L 1645 P 197	7.8	AVIGATION EASEMENT; MINIMUM HEIGHT RESTRICTIONS APPLY
49E	JOSEPH C. AND JULE VANWINKLE	COUNTY OF ALBANY	FEB. 27, 1961	L 1676 P 161	1.5	AVIGATION EASEMENT; MINIMUM HEIGHT RESTRICTIONS APPLY
50E	WILLIAM H. REBUSMEN	COUNTY OF ALBANY	OCT. 2, 1961	L 1700 P 48	17.0	AVIGATION EASEMENT; MINIMUM HEIGHT RESTRICTIONS APPLY
51E	E. WALTER AND ELIZABETH ENGEL	COUNTY OF ALBANY	JULY 15, 1966	L 1875 P 371	27.8	AVIGATION EASEMENT; MINIMUM HEIGHT RESTRICTIONS APPLY
52E	TRI - CITY INDUSTRIES, INC.	COUNTY OF ALBANY	JAN. 6, 1975	L 2093 P 79	57.1	AIR EASEMENT; MINIMUM HEIGHT RESTRICTIONS APPLY; ALSO SEE PARCEL NO. 68CE
53E	COUNCIL COMMERCE CORPORATION	COUNTY OF ALBANY	DEC. 17, 1975	L 2109 P 267	0.3	AIR EASEMENT; MINIMUM HEIGHT RESTRICTIONS APPLY
54E	JAMES W. AND HELEN COTON	COUNTY OF ALBANY	DEC. 7, 1979	L 2180 P 922	50	AIR EASEMENT; MINIMUM HEIGHT RESTRICTIONS APPLY; EXCHANGE OF EASEMENTS; SEE PARCEL NO. 69CE
55E	ESTATE OF IRVING F. BUHRMASTER	COUNTY OF ALBANY	SEPT. 28, 1983	L 2247 P 179	81	AIR EASEMENT; MINIMUM HEIGHT RESTRICTIONS APPLY
56E	ASHFIELD ASSOCIATES	COUNTY OF ALBANY	DEC. 10, 1990	L 2428 P 969	---	30' WIDE EASEMENT FOR WASTE GLYCOL SEWER MAIN
PARCEL NO.	GRANTOR	GRANTEE	DEED DATE	RECORDED	AREA (AC. +/-)	REMARKS
57C	COUNTY OF ALBANY	JOHN F. A. AND LOUISA B. HELLWIG	APR. 3, 1975	L 2096 P 145	0.8	
58C	COUNTY OF ALBANY	CONN REALTY CORPORATION	DEC. 20, 1977	L 2143 P 1119	0.3	LAND SWAP; SEE PARCEL NO. 17
59C	COUNTY OF ALBANY	TOWN OF COLONIE	APR. 2, 1980	L 2185 P 1153	2.4	SEE PARCEL NO. 70CE
60C	COUNTY OF ALBANY	PEPSI-COLA ALBANY BOTTLING CO, INC	NOV. 2, 1982	L 2230 P 1035	4.8	SUBJECT TO RESTRICTIVE COVENANTS; ALSO, SEE PARCEL NO. 69CE
61C	COUNTY OF ALBANY	THE PEOPLE OF THE STATE OF NEW YORK	AUG. 27, 1984	L 2268 P 193	3.6	SUBJECT TO RIGHTS OF REVERTER TO COUNTY OF ALBANY
62C	COUNTY OF ALBANY	COMMAND AIRWAYS, INC.	OCT. 30, 1986	L 2335 P 723	0.4	SEE PARCEL NO. 71CE
63CE	COUNTY OF ALBANY	NIAGARA MDHAWK POWER CORP.	DEC. 13, 1965	L 1858 P 341	---	10' WIDE RIGHT OF WAY AND EASEMENT FOR GAS MAIN
64CE	LOUISA B. AND JOHN F. A. HELLWIG	TOWN OF COLONIE	NOV. 19, 1973	L 2062 P 267	---	SANITARY SEWER EASEMENT
65CE	COUNTY OF ALBANY	TOWN OF COLONIE	DEC. 3, 1973	L 2075 P 263	---	SANITARY SEWER EASEMENT
66CE	COUNTY OF ALBANY	TOWN OF COLONIE	DEC. 3, 1973	L 2075 P 266	---	SANITARY SEWER EASEMENT
67CE	COUNTY OF ALBANY	TOWN OF COLONIE	DEC. 3, 1973	L 2075 P 323	---	SANITARY SEWER EASEMENT
68CE	COUNTY OF ALBANY	TRI-CITY INDUSTRIES, INC.	JAN. 6, 1975	L 2093 P 79	---	EASEMENT AND RIGHT OF WAY FOR INGRESS, EGRESS AND UTILITIES INSTALLATION; ALSO, SEE PARCEL NO. 52E
69CE	COUNTY OF ALBANY	JAMES W. AND HELEN COTON	DEC. 7, 1979	L 2180 P 922	---	EASEMENT AND RIGHT OF WAY FOR INGRESS, EGRESS AND UTILITIES INSTALLATION; CORRECTIVE DEED L 2230 P 1033 ISSUED NOV. 2, 1982 TO PEPSI-COLA ALBANY BOTTLING CO, INC. OVER SAME PARCEL; ALSO, SEE PARCEL NO. 60C
70CE	COUNTY OF ALBANY	TOWN OF COLONIE	APR. 2, 1980	L 2185 P 1153	---	PROTECTIVE EASEMENT AND WATER MAIN EASEMENT; ALSO, SEE PARCEL 59C
71CE	COUNTY OF ALBANY	COMMAND AIRWAYS, INC.	OCT. 30, 1986	L 2335 P 723	---	DRAINAGE EASEMENT AND RIGHT TO CLEAR EXISTING DITCH FOR DRAINAGE; ALSO, SEE PARCEL 62C
72CE	COUNTY OF ALBANY	TOWN OF COLONIE	OCT. 26, 1990	L 2427 P 79	---	WATER MAIN EASEMENT
73R	COUNCIL COMMERCE CORPORATION	COUNTY OF ALBANY	NOV. 24, 1975	L 2109 P 221	---	RESTRICTIVE COVENANTS ON THIS PARCEL CONCERNING AIR AND NOISE POLLUTION
74	EUGENE P. DEVINE, CO. TREAS. FOR THE COUNTY OF ALBANY	COUNTY OF ALBANY	SEPT. 14, 1966	L 1883 P 51	0.9	FORMERLY OWNED BY EMILY HARGRAVES. ALBANY COUNTY FORECLOSED FOR DELINQUENT TAXES. JURISDICTION REPUTEDLY TRANSFERRED FROM ALBANY CO. REAL PROPERTY TO ALBANY CO. AIRPORT FEB. 1987.

NOTE:

THIS MAP AND LAND INVENTORY DEED TABULATION REPRESENTS A COMPILATION OF LANDS, PARCELS AND PROPERTIES OF THE ALBANY COUNTY AIRPORT AUTHORITY PREPARED FROM DEEDS OF RECORD, LAND SURVEY MAPS, LAND LEASE DOCUMENTS, HIGHWAY RIGHT-OF-WAY MAPS, AND OTHER LAND RECORD SOURCES PROVIDED TO L. SIPPERLY & ASSOCIATES, D.P.C.



L. SIPPERLY & ASSOCIATES, D.P.C.
ENGINEERS • SURVEYORS • LAND PLANNERS

AIRPORT PROPERTY MAP
EXHIBIT "A" - SHEET 7
LAND TABULATION

ALBANY COUNTY AIRPORT AUTHORITY
ALBANY, NEW YORK

LAST REVISED: 1/31/19

DESIGNED BY: [blank] DRAWN BY: [blank] CHECKED BY: [blank] ESTIMATED BY: [blank]

PARCEL NO.	GRANTOR	GRANTEE	DEED DATE	RECORDED	AREA (AC. +/-)	REMARKS
75	RONALD A. MINCH & LEATRICE H. FONDA	COUNTY OF ALBANY	OCT. 10, 1991	L.2446 P.574	---	8.03-1-53
76	DOUGLAS H. & DOROTHY R. CADY	COUNTY OF ALBANY	SEPT. 19, 1991	L.2445 P. 33	---	8.03-1-52
77	SACHA F. PERCENT	COUNTY OF ALBANY	JUNE 29, 1993	L.2486 P. 501	---	18.00-2-21
78	JACK C.F. JANG	COUNTY OF ALBANY	MAR. 22, 1991	L.2434 P. 241	---	18.00-2-20
79	YVONNE SGAMBELLURI	COUNTY OF ALBANY	SEPT. 2, 1993	L.2491 P. 669	---	18.00-2-16
80CE	COUNTY OF ALBANY	N.Y. POWER & LIGHT CO.	MAY 17, 1928	L.811 P. 74	---	PARCEL 2 / ELEC LINE ESMT.
81CE	LOUIS & ANNA SCHULTZ	N.Y. POWER & LIGHT CO.	APRIL 11, 1929	L.813 P. 275	---	PARCEL 9 / ELEC LINE ESMT.
82CE	LOUIS & ANNA SCHULTZ	N.Y. POWER & LIGHT CO.	APRIL 23, 1929	L.825 P. 220	---	PARCEL 17 / ELEC LINE ESMT.
83CE	LOUIS & ANNA SCHULTZ	N.Y. POWER & LIGHT CO.	MARCH 18, 1930	L.825 P. 407	---	PARCEL 9 / ELEC LINE ESMT.
84CE	ROBERT P. KELLY	N.Y. POWER & LIGHT CO.	SEPT. 25, 1934	L.871 P. 227	---	PARCEL 1 - 50 PINEGROVE / ELEC LINE ESMT.
85CE	JOHN W. HELLMG	N.Y. POWER & LIGHT CO.	SEPT. 5, 1935	L.873 P. 367	---	PARCEL 15 / ELEC LINE ESMT.
86CE	HARVEY S. & TILLIE H. BAUMES	N.Y. POWER & LIGHT CO.	JAN. 9, 1942	L.938 P. 359	---	PARCEL 14 / ELEC LINE ESMT.
87CE	KATHERINE X. RUF	N.Y. POWER & LIGHT CO.	JUNE 10, 1942	L.938 P. 361	---	PARCEL 19 / ELEC LINE ESMT.
88CE	HARVEY S. & TILLIE H. BAUMES	N.Y. POWER & LIGHT CO.	DEC. 28, 1951	L.1296 P. 75	---	PARCEL 1 / ELEC LINE ESMT.
89CE	JOHN HELLMG	N.Y. TELEPHONE CO.	DEC. 21, 1951	L.1300 P. 103	---	PARCEL 15 / TEL LINE ESMT.
90CE	FRANCIS E. LOGAN	N.Y. TELEPHONE CO.	MAY 13, 1960	L.1659 P. 217	---	PARCEL 1 / U/G TEL ESMT.
91CE	WILLIAM H. REBUSMEN	LATHAM WATER DISTRICT	AUG. 8, 1961	L.1692 P. 231	---	PARCEL 50E / WATER LINE ESMT.
92CE	COUNTY OF ALBANY	NIAGARA MOHAWK POWER CORP.	JUNE 14, 1966	L.1858 P. 337	---	PARCEL 47E / GAS LINE ESMT.
93CE	COUNTY OF ALBANY	CITY OF WATERVLIET, N.Y.	AUG. 10, 1966	L.1878 P. 313	---	PARCEL 1 / WATER LINE ESMT.
94CE	THEODORE & MARJORIE PRINCE	NIAGARA MOHAWK POWER CORP.	OCT. 29, 1968	L.1958 P. 23	---	PARCEL 12 / GAS LINE ESMT.
95CE	JAMES RADLEY	N.Y. TELEPHONE CO.	AUG. 4, 1969	L.1983 P. 195	---	PARCEL 23 / U/G TELEPHONE ESMT.
96CE	A.H. HARRIS & SONS, INC.	N.Y. TELEPHONE CO.	JULY 1, 1970	L.2013 P. 18	---	PARCEL 35 / U/G TELEPHONE ESMT.
97CE	THEODORE M. & MARJORIE M. PZENICZNY	TOWN OF COLONIE	MAY 11, 1973	L.2063 P. 817	---	PARCEL 12 / SEWER LINE ESMT.
98CE	COUNTY OF ALBANY	ANNA, LOUISE, & THERESA RUF	JULY 12, 1974	L.2084 P. 335	---	PARCEL 59C / RESERVES INGRESS/EGRESS ESMT.
99CE	YVONNE SGAMBELLURI	TOWN OF COLONIE	JULY 21, 1975	L.2101 P. 199	---	PARCEL 79 / SEWER LINE ESMT.
100CE	COUNTY OF ALBANY	NIAGARA MOHAWK POWER CORP.	JAN. 5, 1977	L.2125 P. 631	---	ANN LEE PROP. / U/G ELEC ESMT.
101CE	COUNTY OF ALBANY	TOWN OF COLONIE	JAN. 19, 1977	L.2126 P. 317	---	ALBANY-SHAKER RD / WATER ESMT.
102CE	COUNTY OF ALBANY	NIAGARA MOHAWK POWER CORP.	FEB. 15, 1977	L.2127 P. 245	---	PARCEL 2 / ALBANY-SHAKER WEST OF AIRPORT / ELEC LINE ESMT.
103	TURF CONSTRUCTION CO. INC.	COUNTY OF ALBANY	APRIL 11, 1977	L.2129 P. 1159	---	18.00-4-6.1
104CE	JOSEPH WUNDERLICH	TOWN OF COLONIE	NOV. 4, 1977	L.2140 P. 1097	---	PARCEL 29 / SEWER
105CE	FRANK MARKUS	NIAGARA MOHAWK & N.Y. TELEPHONE	NOV. 25, 1977	L.2142 P. 63	---	PARCELS 1,9,17 / U/G ELEC & TEL ESMT.
106CE	KENNETH A. & BARBARA R. REBUSMEN	TOWN OF COLONIE	JUNE 7, 1978	L.2150 P. 1059	---	PARCEL 50E / WATER ESMT.
107E	JOHN J. & ELIZABETH A. HUBAN	COUNTY OF ALBANY	JUNE 28, 1979	L.2171 P. 445	---	18.00-4-25.1 / AIR ESMT.
108RE	COUNTY OF ALBANY	WARREN SCHULTZ	DEC. 6, 1979	L.2180 P. 229	---	RELEASE AIR ESMT.
109C	COUNTY OF ALBANY	JAMES W. COTON	DEC. 18, 1979	L.2180 P. 879	---	18.02-6-6.3.2
110C	COUNTY OF ALBANY	PEOPLE OF THE STATE OF NEW YORK	AUG. 8, 1980	L.2422 P. 76	---	PARCEL 27
111C	COUNTY OF ALBANY	PEOPLE OF THE STATE OF NEW YORK	SEPT. 7, 1990	L.2422 P. 976	---	PARCEL 23
112CE	COUNTY OF ALBANY	NIAGARA MOHAWK & N.Y. TELEPHONE	OCT. 24, 1984	L.2270 P. 636	---	PARCEL 1 / U/G ELEC & TEL TO MALL AIR
113CE	COUNTY OF ALBANY	COMMAND AIRWAYS, INC.	DEC. 20, 1984	L.2274 P. 839	---	PARCEL 1 / TAXIWAY - R.O.W. ESMT
114CE	COUNTY OF ALBANY	NIAGARA MOHAWK & N.Y. TELEPHONE	MAY 27, 1987	L.2338 P. 135	---	PARCEL 1 / U/G TEL, ELEC & GAS ESMT.
115	SHAKER RIDGE COUNTRY CLUB, INC.	COUNTY OF ALBANY	OCT. 4, 1988	L.2374 P. 293	---	RESERVES INGRESS/EGRESS ESMT & WATER LINE ESMT.
116CE	COUNTY OF ALBANY	NIAGARA MOHAWK & N.Y. TELEPHONE	MAY 8, 1989	L.2385 P. 973	---	PARCEL 1 / U/G ELEC, TEL & GAS ESMT.
117	JAMES J. & SUZZANNE RUTKOWSKI	COUNTY OF ALBANY	JUNE 12, 1991	L.2438 P. 1057	---	18.00-3-20
118CE	COUNTY OF ALBANY	TOWN OF COLONIE	JULY 22, 1991	L.2441 P. 260	---	PARCEL 25 / SEWER LINE ESMT.
119CE	COUNTY OF ALBANY	TOWN OF COLONIE	JULY 22, 1991	L.2441 P. 270	---	PARCEL 34 / SEWER LINE ESMT.

NOTE:

THIS MAP AND LAND INVENTORY DEED TABULATION REPRESENTS A COMPILATION OF LANDS, PARCELS AND PROPERTIES OF THE ALBANY COUNTY AIRPORT AUTHORITY PREPARED FROM DEEDS OF RECORD, LAND SURVEY MAPS, LAND LEASE DOCUMENTS, HIGHWAY RIGHT-OF-WAY MAPS, AND OTHER LAND RECORD SOURCES PROVIDED TO L. SIPPERLY & ASSOCIATES, D.P.C.



L. SIPPERLY & ASSOCIATES, D.P.C.
ENGINEERS • SURVEYORS • LAND PLANNERS

AIRPORT PROPERTY MAP
EXHIBIT "A" - SHEET 8
LAND TABULATION

ALBANY COUNTY AIRPORT AUTHORITY
ALBANY, NEW YORK

LAST REVISED: 1/31/19

DATE DEED BY DWYD BY ESTABD BY DECD BY

PARCEL NO.	GRANTOR	GRANTEE	DEED DATE	RECORDED	AREA (AC. +/-)	REMARKS
120CE	COUNTY OF ALBANY	TOWN OF COLONIE	JULY 22, 1991	L.2441 P. 275	---	PARCEL 32 / SEWER LINE ESMT.
121CE	COUNTY OF ALBANY	TOWN OF COLONIE	JULY 22, 1991	L.2441 P. 279	---	PARCEL 4 / SEWER LINE ESMT.
122CE	COUNTY OF ALBANY	NIAGARA MOHAWK & N.Y. TELEPHONE	NOV. 6, 1991	L.2448 P. 101	---	PARCEL 1 / U/G ELEG & TEL ESMT.
123CE	COUNTY OF ALBANY	TOWN OF COLONIE	NOV. 19, 1991	L.2448 P. 1019	---	PARCEL 2 / SEWER LINE ESMT.
124CE	VERDOY VOLUNTEER FIRE ASSOC.	TOWN OF COLONIE	NOV. 12, 1992	L.2471 P. 1005	---	PARCEL 48E / SEWER LINE ESMT.
125CE	COUNTY OF ALBANY	TOWN OF COLONIE	NOV. 12, 1992	L.2471 P. 1010	---	PARCEL 40 / SEWER LINE ESMT.
126CE	COUNTY OF ALBANY	TOWN OF COLONIE	NOV. 12, 1992	L.2471 P. 1014	---	PARCEL 37 / SEWER LINE ESMT.
127	JOSEPH R. & JEAN B. WUNDERLICH	COUNTY OF ALBANY	APRIL 9, 1993	L.2481 P. 591	---	18.00-3-5
128E	JOHN J. & EDWARD K. ENGEL	COUNTY OF ALBANY	OCT. 18, 1993	L.2494 P. 832	---	30.00-5-1 / AIR ESMT.
129	JEAN A. LOVVO	COUNTY OF ALBANY	MARCH 15, 1994	L.2505 P. 110	---	18.00-3-16
130CE	YVONNE SGAMBELLURI	TOWN OF COLONIE	AUG. 8, 1991	L.2443 P. 455	---	PARCEL 79 / SEWER LINE ESMT.
131	MARTIN SCHMIDT	ALBANY COUNTY AIRPORT AUTHORITY	FEB. 28, 1995	L.2532 P. 208	---	18.00-3-13
132	IRENE CUSHMAN	COUNTY OF ALBANY	MAY 11, 1995	L.2533 P. 819	---	8.03-1-10
133E	ROBERT J. & JUDITH C. ZAPOLSKI	COUNTY OF ALBANY	JAN. 25, 1995	L.2527 P. 320	---	8.03-1-48.21/ AIR ESMT.
134E	MICHAEL CHRYS	ALBANY COUNTY AIRPORT AUTHORITY	MAR. 13, 1995	L.2530 P. 130	---	18.02-1-3/ AIR ESMT. // REFILED AS L.2562 P.815
135E	JANET EMPIE-PAYNE	ALBANY COUNTY AIRPORT AUTHORITY	APRIL 12, 1995	L.2531 P. 721	---	8.03-1-56/AIR ESMT.
136	INTERMAGNETICS GENERAL CORPORATION	ALBANY COUNTY AIRPORT AUTHORITY	MAR. 12, 1996	L.2552 P. 278	---	PORTION OF 18.00-3-24.2
137	ALBANY COUNTY AIRPORT AUTHORITY	COUNTY OF ALBANY	JUNE 21, 1996	L.2558 P. 863	---	PORTION OF 18.00-3-24.2
138E	MICHAEL F. & GERALD E. MANGIONE	ALBANY COUNTY AIRPORT AUTHORITY	JULY 30, 1996	L.2561 P. 115	---	18.00-2-23/ AIR ESMT. (REF. 49E - VAN WINKLE)
139	JOYCE E. GALLUP	ALBANY COUNTY AIRPORT AUTHORITY	NOV.1, 1996	L.2567 P. 772	---	18.00-3-12
140	WALTER V. & STANLEY DISTEFANO	ALBANY COUNTY AIRPORT AUTHORITY	JULY 14, 1995	L.2589 P. 85	---	18.00-3-39/IN 2448-95 R/I NO. 0195 041676
141	DAVID J. KAISER	COUNTY OF ALBANY	SEPT. 4, 1996	L.2564 P. 969	---	18.00-2-30
142	COUNTY OF ALBANY	DAVID J. KAISER	SEPT. 9, 1996	L.2564 P. 1021	---	18.00-2-31 & PORTION OF 18.00-2-29 (REF. 21 & 22)
143	BUDLONG ENTERPRISES, INC.	ALBANY COUNTY AIRPORT AUTHORITY	1996	---	---	18.00-3-23.2 (EMINENT DOMAIN)
144	JACKSON L. & RUTH B. SOTHERN	ALBANY COUNTY AIRPORT AUTHORITY	1996	---	---	18.00-3-24.12 (EMINENT DOMAIN)
145CE	COUNTY OF ALBANY	TOWN OF COLONIE	MARCH 28, 1996	L.2555 P. 442	---	WATER LINE EASEMENT - FUEL FARM
146E	LORRAINE B. SYMANSKI, ET AL.	COUNTY OF ALBANY	AUGUST 3, 1993	L.2555 P. 962	---	8.03-1-49 / AVIGATION EASEMENT
147L	ALBANY COUNTY AIRPORT AUTHORITY	CELLCO PARTNERSHIP	MAY 21, 1996	L.2560 P. 420	---	LEASE AGREEMENT - WITHIN TERMINAL BUILDING
---	COUNTY OF ALBANY	ALBANY COUNTY AIRPORT AUTHORITY	JULY 2, 1996	L.2561 P. 918	---	AIRPORT LEASE AGREEMENT
148E	ANDREW EMPIE	ALBANY COUNTY AIRPORT AUTHORITY	JUNE 3, 1996	L.2562 P. 289	---	8.03-1-57 / AVIGATION EASEMENT/ L.2562 P. 296
149E	ANNE MARIE DEMARCKEN	COUNTY OF ALBANY	SEPT. 14, 1996	L.2562 P. 769	---	8.03-1-50 / AVIGATION EASEMENT
150E	MEL WALDMAN	ALBANY COUNTY AIRPORT AUTHORITY	MARCH 22, 1996	L. 2563 P. 119	---	18.02-1-1 / AVIGATION EASEMENT
151E	NICHOLAS L. & VERA M. FRANGELLA	COUNTY OF ALBANY	APRIL 23, 1993	L.2485 P. 554	---	PORTION OF 8.03-1-48.1/AVIGATION EASEMENT
152E	ELIZABETH & CHRISTOPHER P. AMBROSE	COUNTY OF ALBANY	MAY 4, 1993	L.2485 P. 561	---	8.03-1-47/AVIGATION EASEMENT
153E	JAMES C. ANDERSON	COUNTY OF ALBANY	APRIL 27, 1993	L.2485 P. 568	---	PORTION OF 18.00-2-11/AVIGATION EASEMENT
154E	PAUL J. CITONE	COUNTY OF ALBANY	JUNE 16, 1993	L. 2585 P. 574	---	8.03-1-45/AVIGATION EASEMENT
155E	JOHN CERONE, JR.	COUNTY OF ALBANY	SEPT. 29, 1993	L.2493 P. 881	---	PORTION OF 30.00-5-10/AVIGATION EASEMENT
156E	JAMES C. ANDERSON, JR.	COUNTY OF ALBANY	AUG. 3, 1993	L.2493 P. 888	---	18.00-2-11/AVIGATION EASEMENT
157E	ESTELLE J. ELKA	COUNTY OF ALBANY	SEPT. 29, 1993	L.2495 P. 549	---	8.03-1-46/AVIGATION EASEMENT
158E	PAUL J. CITONE	COUNTY OF ALBANY	SEPT. 29, 1993	L.2496 P. 770	---	8.03-1-45/AVIGATION EASEMENT
159E	ELMER S. FRIEDBERG & FAYE SCOTT	ALBANY COUNTY AIRPORT AUTHORITY	DEC. 9, 1993	L.2504 P. 835	---	18.00-2-13/AVIGATION EASEMENT
160E	MICHAEL F. & GERARD E. MANGIONE	ALBANY COUNTY AIRPORT AUTHORITY	JUNE 13, 1995	L.2485 P. 561	---	18.00-2-23/AVIGATION EASEMENT

NOTE:
 THIS MAP AND LAND INVENTORY DEED TABULATION REPRESENTS A COMPILATION OF LANDS, PARCELS AND PROPERTIES OF THE ALBANY COUNTY AIRPORT AUTHORITY PREPARED FROM DEEDS OF RECORD, LAND SURVEY MAPS, LAND LEASE DOCUMENTS, HIGHWAY RIGHT-OF-WAY MAPS, AND OTHER LAND RECORD SOURCES PROVIDED TO L. SIPPERLY & ASSOCIATES, DPC.



L. SIPPERLY & ASSOCIATES, D.P.C.
 ENGINEERS • SURVEYORS • LAND PLANNERS

AIRPORT PROPERTY MAP
 EXHIBIT "A" - SHEET 9
 LAND TABULATION

ALBANY COUNTY AIRPORT AUTHORITY
 ALBANY, NEW YORK

LAST REVISED: 1/31/19

PARCEL NO.	GRANTOR	GRANTEE	DEED DATE	RECORDED	AREA (AC. +/-)	REMARKS
161L	DOUGLAS J. LUSTIG/METRO AIRLINES NE	ALBANY COUNTY AIRPORT AUTHORITY	DEC. 19, 1996	L.2571 P. 651	---	LEASE AGREEMENT - BROCKWAY AIR, INC. FACILITY
162	LORRAINE B. SYMANSKI	ALBANY COUNTY AIRPORT AUTHORITY	SEPT. 29, 1993	L.2496 P. 770	---	8.03-1-49 (146E)
163C	ALBANY COUNTY AIRPORT AUTHORITY	COUNTY OF ALBANY	JUNE 19, 1996	L.2573 P. 172	---	18.00-3-23.2, 24.12, & 24.22
164	MICHAEL F. & GERARD E. MANGIONE	ALBANY COUNTY AIRPORT AUTHORITY	APRIL 25, 1997	L.2578 P. 275	---	18.00-2-23
165	CHERE T. OWTT	ALBANY COUNTY AIRPORT AUTHORITY	JULY 2, 1997	L.2582 P. 391	---	18.00-4-22
166	CHARLES F., JR. & DOROTHY A. LITTLE	ALBANY COUNTY AIRPORT AUTHORITY	JULY 23, 1997	L.2583 P. 699	---	30.00-3-20
167	EDWARD F. DEXTRAZE	ALBANY COUNTY AIRPORT AUTHORITY	JULY 29, 1997	L.2583 P. 1087	---	30.00-3-19
168	CARLSBURY GONZALEZ	ALBANY COUNTY AIRPORT AUTHORITY	JULY 29, 1997	L.2583 P. 1122	---	30.00-3-25
169	1500 CENTRAL AVENUE ASSOCIATES	ALBANY COUNTY AIRPORT AUTHORITY	JULY 17, 1997	L.2584 P. 442	---	18.00-4-25.1
170E	KEN. C., RICH. J. & KEN. A. REBUSMEN	ALBANY COUNTY AIRPORT AUTHORITY	AUG. 15, 1995	L.2587 P. 876	---	PORTION OF 18.00-3-1/AVIGATION EASEMENT
171	EILEEN NALL	ALBANY COUNTY AIRPORT AUTHORITY	OCT. 17, 1997	L.2589 P. 32	---	18.00-4-20
172	ANITA A. MILLER & FRED H. BARRON	ALBANY COUNTY AIRPORT AUTHORITY	NOV. 12, 1997	L.2590 P. 1035	---	30.00-3-23.1
173	ANITA A. MILLER & FRED H. BARRON	ALBANY COUNTY AIRPORT AUTHORITY	NOV. 12, 1997	L.2590 P. 1037	---	30.00-3-23.2
174E	GEORGE F. BUHRMASTER	ALBANY COUNTY AIRPORT AUTHORITY	OCT. 31, 1995	L.2592 P. 17	---	8.03-1-65/AVIGATION EASEMENT/IN. 5544-95 R/J NO. 0195 043368
174E	GEORGE F. BUHRMASTER	ALBANY COUNTY AIRPORT AUTHORITY	OCT. 31, 1995	L.2592 P. 21	---	8.03-1-65/AVIGATION EASEMENT/IN. 5543-95 R/J NO. 0195 043369
175E	EDWARD I., SR. & MAY. F. BUHRMASTER	ALBANY COUNTY AIRPORT AUTHORITY	OCT. 31, 1995	L.2592 P. 25	---	8.03-1-66/AVIGATION EASEMENT/IN. 5542-95 R/J NO. 0195 043367
176	VINCENT L. COLELLO	ALBANY COUNTY AIRPORT AUTHORITY	DEC. 31, 1997	L.2594 P. 145	---	30.00-3-22
177	ELIZABETH R. SORNBERGER	ALBANY COUNTY AIRPORT AUTHORITY	JAN. 21, 1998	L.2595 P. 388	---	18.00-2-38
178	ELIZABETH R. SORNBERGER	ALBANY COUNTY AIRPORT AUTHORITY	JAN. 20, 1998	L.2595 P. 392	---	18.00-2-40
179	WALTER W. HUBBARD	ALBANY COUNTY AIRPORT AUTHORITY	APRIL 10, 1998	L.2600 P. 735	---	30.00-3-29
180	NICHOLAS L. & VERA M. FRANGELLA	ALBANY COUNTY AIRPORT AUTHORITY	APRIL 27, 1998	L.2601 P. 905	---	8.03-1-48.1
181	BERNARD MARTINESE	ALBANY COUNTY AIRPORT AUTHORITY	JULY 22, 1998	L.2608 P. 35	---	18.00-3-7
182	DAVID P., JR. & CYNTHIA J. ALLEN	ALBANY COUNTY AIRPORT AUTHORITY	JULY 23, 1998	L.2608 P. 137	---	8.03-1-60
183E	JOSEPH C. & GLADYS M. DONAWICK	ALBANY COUNTY AIRPORT AUTHORITY	JULY 17, 1995	L.2609 P. 102	---	8.03-1-63/AVIGATION EASEMENT/IN. 2291-95 R/J NO. 0195 041604
184	WM. J. DONAWICK & BARB. J. SCHLEUSE	ALBANY COUNTY AIRPORT AUTHORITY	AUG. 31, 1998	L.2611 P.404/406	---	8.03-1-63
185	MASTA M. FINCH	ALBANY COUNTY AIRPORT AUTHORITY	SEPT. 18, 1998	L.2612 P. 584	---	18.00-3-11
186	THE VERDOY FIRE DEPARTMENT	ALBANY COUNTY AIRPORT AUTHORITY	SEPT. 28, 1998	L.2613 P. 208	---	18.00-2-26 & 27
187E	THE VERDOY FIRE ASSOCIATION	ALBANY COUNTY AIRPORT AUTHORITY	OCT. 31, 1995	L.2613 P. 485	---	18.00-2-26/AVIGATION EASEMENT/IN. 5602-95 R/J NO. 0195 043384
188E	THE VERDOY FIRE DEPARTMENT	ALBANY COUNTY AIRPORT AUTHORITY	OCT. 31, 1995	L.2613 P. 490	---	18.00-2-27/AVIGATION EASEMENT/IN. 5603-95 R/J NO. 0195 043385
189	JAMES F. & TAMMY L. FERRAIOLI	ALBANY COUNTY AIRPORT AUTHORITY	NOV. 6, 1998	L.2616 P. 549	---	30.00-3-17
190CE	ALBANY COUNTY AIRPORT AUTHORITY	TOWN OF COLONIE	NOV. 23, 1998	L.2618 P. 48	---	ENCUMBRANCE ON UTIL. EASEMENT/AGREEMENT- PORTION OF 72E
191	REBUSMEN'S FARM	ALBANY COUNTY AIRPORT AUTHORITY	JAN. 5, 1999	L.2620 P. 530	---	18.00-3-1
192	ROBIN P. ZOLLER	ALBANY COUNTY AIRPORT AUTHORITY	JAN. 13, 1999	L.2621 P. 19	---	30.00-3-18
193	BERNARD & MARY MARTINESE	ALBANY COUNTY AIRPORT AUTHORITY	FEB. 16, 1999	L.2623 P. 623	---	18.00-3-51
194	MARY MARTINESE	ALBANY COUNTY AIRPORT AUTHORITY	FEB. 16, 1999	L.2623 P. 625	---	18.00-3-46, 47, 48
195E	VILLAGE SQUARE OF PENNA., INC.	ALBANY COUNTY AIRPORT AUTHORITY	FEB. 27, 1998	L.2626 P. 481	---	PORTIONS OF 30.00-5-5 & 8/AVIGATION EASEMENT
196E	PAUL C. & RUSSELL & NANCY RUSSELL	ALBANY COUNTY AIRPORT AUTHORITY	JULY 17, 1995	L. 2734 P. 684	0.7	8.03-1-58/AVIGATION EASEMENT/IN. 2298-95 R/J NO. 0195 041611
197E	CHARLES DENIMSON	ALBANY COUNTY AIRPORT AUTHORITY	OCT. 29, 1999	L. 2642 P. 601	---	18.02-1-2/AVIGATION EASEMENT/IN. 5541-95 R/J NO. 0195 043366
198E	BET-LOU, INCORPORATED	ALBANY COUNTY AIRPORT AUTHORITY	OCT. 29, 1999	L. 2642 P. 599	---	18.00-2-25/AVIGATION EASEMENT/IN. 5540-95 R/J NO. 0195 043365
199E	ROBERT P. BUFE, II & JEAN M. BUFE	ALBANY COUNTY AIRPORT AUTHORITY	JUNE 21, 2000	L. 2658 P. 512	---	18.00-2-12/AVIGATION EASEMENT/IN. 6323-95 R/J NO. 0195 043722
200	CARLOS S. TEIXEIRA, ET. AL.	ALBANY COUNTY AIRPORT AUTHORITY	OCT. 9, 2001	L. 2692 P. 860	.7	8.03-1-68 FEE PARCEL PREVIOUSLY PARCEL NO. 200E
201	KAREN BATKO, ET. AL.	ALBANY COUNTY AIRPORT AUTHORITY	DEC. 18, 2000	L. 2672 P. 50	0.5	18.00-3-15
202	KAYAN HOLDINGS, L.L.C.	ALBANY COUNTY AIRPORT AUTHORITY	JULY 24, 2000	L. 2661 P. 239	1.1	8.03-1-47

NOTE:

THIS MAP AND LAND INVENTORY DEED TABULATION REPRESENTS A COMPILATION OF LANDS, PARCELS AND PROPERTIES OF THE ALBANY COUNTY AIRPORT AUTHORITY PREPARED FROM DEEDS OF RECORD, LAND SURVEY MAPS, LAND LEASE DOCUMENTS, HIGHWAY RIGHT-OF-WAY MAPS, AND OTHER LAND RECORD SOURCES PROVIDED TO L. SIPPERLY & ASSOCIATES, D.P.C.



L. SIPPERLY & ASSOCIATES, D.P.C.
ENGINEERS • SURVEYORS • LAND PLANNERS

AIRPORT PROPERTY MAP
EXHIBIT "A" - SHEET 10
LAND TABULATION

ALBANY COUNTY AIRPORT AUTHORITY
ALBANY, NEW YORK

LAST REVISED: 1/31/19

DRAWN BY: [unreadable] CHECKED BY: [unreadable] ESTIMATED BY: [unreadable] REVISIONS: [unreadable]

PARCEL NO.	GRANTOR	GRANTEE	DEED DATE	RECORDED	AREA (AC. +/-)	REMARKS
203	VELLANO BROS., INC.	ALBANY COUNTY AIRPORT AUTHORITY	SEPT. 20, 2000	L. 2665 P. 582	0.4	30.00-3-16
204	VELLANO BROS., INC.	ALBANY COUNTY AIRPORT AUTHORITY	SEPT. 26, 2000	L. 2665 P. 586	1.6	30.00-3-15
205	DAVID J. KAISER & EILEEN JANET KAISER	ALBANY COUNTY AIRPORT AUTHORITY	JULY 3, 2001	L. 2684 P. 1079	2.5	18.00-2-37.12
206	DAVID J. KAISER & EILEEN JANET KAISER	ALBANY COUNTY AIRPORT AUTHORITY	JULY 3, 2001	L. 2684 P. 1079	---	18.00-2-37.2
207	DAVID J. KAISER & EILEEN JANET KAISER	ALBANY COUNTY AIRPORT AUTHORITY	JULY 3, 2001	L. 2684 P. 1079	---	18.00-2-33.2
208	DAVID J. KAISER & EILEEN JANET KAISER	ALBANY COUNTY AIRPORT AUTHORITY	JULY 3, 2001	L. 2684 P. 1079	---	18.00-2-36
209	DAVID J. KAISER & EILEEN JANET KAISER	ALBANY COUNTY AIRPORT AUTHORITY	JULY 3, 2001	L. 2684 P. 1079	---	18.00-2-32
210	DAVID J. KAISER & EILEEN JANET KAISER	ALBANY COUNTY AIRPORT AUTHORITY	JULY 3, 2001	L. 2684 P. 1079	---	18.00-2-31
211	DAVID J. KAISER & EILEEN JANET KAISER	ALBANY COUNTY AIRPORT AUTHORITY	JULY 3, 2001	L. 2684 P. 1079	---	18.00-2-33.12
212	NANCY A. KREUGLER	ALBANY COUNTY AIRPORT AUTHORITY	AUG. 21, 2001	L. 2689 P. 74	2.7	19.03-1-31
213	MARCELLO DeANGELIS	ALBANY COUNTY AIRPORT AUTHORITY	SEPT. 28, 2001	L. 2692 P. 1069	0.6	30.00-3-30
214	TIMOTHY H. BURNHAM, ET. AL.	ALBANY COUNTY AIRPORT AUTHORITY	DEC. 7, 2001	L. 2698 P. 831	0.4	30.00-3-28
215	JAMES G. & HELEN J. ESPEY	ALBANY COUNTY AIRPORT AUTHORITY	DEC. 6, 2001	L. 2698 P. 1067	0.5	30.00-3-27
216	CAIRNS MORTGAGE TRUST	ALBANY COUNTY AIRPORT AUTHORITY	JAN. 10, 2002	L. 2684 P. 1079	0.6	30.00-3-12.1
217	CAIRNS MORTGAGE TRUST	ALBANY COUNTY AIRPORT AUTHORITY	JAN. 10, 2002	L. 2684 P. 1079	0.9	30.00-3-12.2
218	CAIRNS MORTGAGE TRUST	ALBANY COUNTY AIRPORT AUTHORITY	JAN. 10, 2002	L. 2684 P. 1079	0.3	30.00-3-31.1
219	CAIRNS MORTGAGE TRUST	ALBANY COUNTY AIRPORT AUTHORITY	JAN. 10, 2002	L. 2684 P. 1079	0.8	30.00-3-31.2
220	CARL E. TOUHEY	ALBANY COUNTY AIRPORT AUTHORITY	JAN. 10, 2002	L. 2700 P. 848	10.1	30.00-3-13
221	RICHARD L. & ELLEN E. SORMBERGER	ALBANY COUNTY AIRPORT AUTHORITY	APRIL 10, 2002	L. 2707 P. 632	0.4	30.00-3-26
222	ALBANY COUNTY AIRPORT AUTHORITY	N.Y.S. DEPARTMENT OF TRANSPORTATION	APRIL 19, 2002	L. 2709 P. 431	---	NOTICE OF APPROPRIATION / ALBANY-SHAKER ROAD MAP NO. 225R-1, PARCELS 239 & 240
223	ALBANY COUNTY AIRPORT AUTHORITY	N.Y.S. DEPARTMENT OF TRANSPORTATION	APRIL 10, 2002	L. 2709 P. 432	---	NOTICE OF APPROPRIATION / ALBANY-SHAKER ROAD MAP NOS. 215, 226, 227, 228, 229, 230, & 231 PARCEL NOS. 194, 229, 241, 242, 243, 244, 245, 246, 247, 276, 283 & 284
224	CONSOLIDATED FREIGHTWAYS CORPORATION OF DELAWARE	ALBANY COUNTY AIRPORT AUTHORITY	MARCH 22, 2002	L. 2709 P. 918	---	30.00-3-14 / 40' ACCESS EASEMENT AND RIGHT-OF-WAY
225	COUNCIL COMMERCE CORPORATION	ALBANY COUNTY AIRPORT AUTHORITY	SEPT. 23, 2002	L. 2720 P. 757	2.9	18.00-4-26
226	COUNCIL COMMERCE CORPORATION	ALBANY COUNTY AIRPORT AUTHORITY	SEPT. 23, 2002	L. 2720 P. 757	9.8	19.03-1-33
227	ALBANY COUNTY AIRPORT AUTHORITY	N.Y.S. DEPARTMENT OF TRANSPORTATION	APRIL 19, 2002	L. 2725 P. 345	---	NOTICE OF APPROPRIATION / ALBANY-SHAKER ROAD MAP NO. 265, PARCELS 307 & 308
228	A.H. HARRIS & SONS, INCORPORATED	ALBANY COUNTY AIRPORT AUTHORITY	DEC. 31, 2002	L. 2727 P. 841	10.5	18.00-2-50.1
229	TIMOTHY J. VINCIGUERRA, ET. AL.	ALBANY COUNTY AIRPORT AUTHORITY	FEB. 21, 2003	L. 2731 P. 162	71.4	30.00-5-9, TOGETHER WITH INGRESS AND EGRESS EASEMENT TO ALBANY-SHAKER ROAD
230	AMERICAN EAGLE AIRLINES, INC.	ALBANY COUNTY AIRPORT AUTHORITY	MAY 7, 2003	L. 2738 P. 639	4.83	18.00-2-51
231	R-19 ASSOCIATES	ALBANY COUNTY AIRPORT AUTHORITY	JUNE 13, 2003	L. 2740 P. 887	--	ASSIGNMENT OF GROUND LEASE
232	R-19 ASSOCIATES	ALBANY COUNTY AIRPORT AUTHORITY	JUNE 13, 2003	L. 2740 P. 923	1.3	---
233	CONSOLIDATED FREIGHTWAYS CORPORATION OF DELAWARE	ALBANY COUNTY AIRPORT AUTHORITY	JUNE 4, 2003	L. 2743 P. 340	6.4	30.00-3-14
234	TOWN OF COLONIE	ALBANY COUNTY AIRPORT AUTHORITY	NOV. 6, 2003	L. 2752 P. 940	0.5	FORMER AIRPORT LANE
235	TOWN OF COLONIE	ALBANY COUNTY AIRPORT AUTHORITY	NOV. 6, 2003	L. 2740 P. 923	1.9	FORMER PINE GROVE ROAD
236	DAVID J. KAISER & JUDY L. KAISER	ALBANY COUNTY AIRPORT AUTHORITY	DEC. 18, 2003	L. 2757 P. 738	4.1	18.00-2-42
237	COUNTY OF ALBANY	ALBANY COUNTY AIRPORT AUTHORITY	---	---	0.9	8.03-1-10
238	CARMEN CAMPBELL, ET. AL.	ALBANY COUNTY AIRPORT AUTHORITY	---	---	1.1	8.03-1-11
239	COUNTY OF ALBANY	ALBANY COUNTY AIRPORT AUTHORITY	---	---	20.0	FORMER ALBANY-SHAKER ROAD, FORMERLY PARCEL 115

NOTE:

THIS MAP AND LAND INVENTORY DEED TABULATION REPRESENTS A COMPILATION OF LANDS, PARCELS AND PROPERTIES OF THE ALBANY COUNTY AIRPORT AUTHORITY PREPARED FROM DEEDS OF RECORD, LAND SURVEY MAPS, LAND LEASE DOCUMENTS, HIGHWAY RIGHT-OF-WAY MAPS, AND OTHER LAND RECORD SOURCES PROVIDED TO L. SIPPERLY & ASSOCIATES, D.P.C.



L. SIPPERLY & ASSOCIATES, D.P.C.
ENGINEERS • SURVEYORS • LAND PLANNERS

AIRPORT PROPERTY MAP
EXHIBIT "A" - SHEET 11
LAND TABULATION

ALBANY COUNTY AIRPORT AUTHORITY
ALBANY, NEW YORK

LAST REVISED: 1/31/19

DRAWN BY: [blank] CHECKED BY: [blank] ESTIMATED BY: [blank] DECEMBER 19, 2019

PARCEL NO.	GRANTOR	GRANTEE	DEED DATE	RECORDED	AREA (AC. +/-)	REMARKS
240	MJK LEASING, LLC	ALBANY COUNTY AIRPORT AUTHORITY	OCT. 13, 2004	L. 2782 P. 306	0.8	18.00-2-37.112
241	ALBANY COUNTY AIRPORT AUTHORITY	MJK LEASING, LLC	OCT. 13, 2004	L. 2787 P. 758	0.8	18.00-2-37.111
242	SANDRA M. D'ADAMO & MATTHEW J. KELLY	ALBANY COUNTY AIRPORT AUTHORITY	DEC. 15, 2004	L. 2787 P. 1066	1.1	08.03-1-11
243	ANDREW S. EMPIE	ALBANY COUNTY AIRPORT AUTHORITY	MARCH 20, 2006	L. 2838 P. 395	0.8	8.03-1-56
244	GENERAL STEEL FABRICATORS, INC.	ALBANY COUNTY AIRPORT AUTHORITY	JUNE 15, 2005	L. 2804 P. 773	12.9	30.00-3-21 & 30.00-3-38
245	GENERAL STEEL FABRICATORS, INC.	ALBANY COUNTY AIRPORT AUTHORITY	JUNE 15, 2005	L. 2804 P. 777	0.1	30.00-3-36
246	ALBANY COUNTY AIRPORT AUTHORITY	COUNTY OF ALBANY	JULY 13, 2005	L. 2808 P. 584	24.0	LANDS TO BE INCLUDED IN AIRPORT LEASE AGREEMENT OLD ALBANY SHAKER ROAD & ALBANY-SHAKER ROAD
247	TOWN OF COLONIE	ALBANY COUNTY AIRPORT AUTHORITY	OCT. 11, 2006	L. 2819 P. 1090	1.1	30.00-3-79 (PORTION OF FORMER WATERVLIET-SHAKER ROAD)
248E	FALLON REALTY, LLC	ALBANY COUNTY AIRPORT AUTHORITY	APRIL 21, 2006	L. 2843 P. 350	1.6	8.03-1-48.221/AVIGATION EASEMENT
249	FALLON REALTY, LLC	ALBANY COUNTY AIRPORT AUTHORITY	APRIL 21, 2006	L. 2843 P. 355	1.6	8.03-1-48.222
250E	INTERMAGNETIC GENERAL CORPORATION	ALBANY COUNTY AIRPORT AUTHORITY	AUG. 17, 2007	L. 2857 P. 1085	7.0	PORTION OF 18.00-3-24.2/AVIGATION EASEMENT
251	MARTHA E. JONES	ALBANY COUNTY AIRPORT AUTHORITY	APRIL 17, 2007	L. 2882 P. 1153	0.4	18.00-2-15
252	TOWN OF COLONIE	ALBANY COUNTY AIRPORT AUTHORITY	DEC. 7, 2007	L. 2906 P. 74	8.4	8.03-1-59
253	JENNIFER A. NEIL	ALBANY COUNTY AIRPORT AUTHORITY	JAN. 14, 2008	L. 2908 P. 756	1.1	08.03-1-47
253E	JENNIFER A. NEIL	ALBANY COUNTY AIRPORT AUTHORITY	JAN. 14, 2008	L. 2908 P. 756	1.1	08.03-1-47/AVIGATION EASEMENT
254E	JENNIFER A. NEIL	ALBANY COUNTY AIRPORT AUTHORITY	JAN. 14, 2008	L. 2908 P. 756	0.5	08.03-1-47/CONSERVATION EASEMENT
255	JENNIFER A. NEIL	ALBANY COUNTY AIRPORT AUTHORITY	JAN. 14, 2008	L. 2911 P. 164	0.6	08.03-1-50
256	NITA BUDLONG	ALBANY COUNTY AIRPORT AUTHORITY	MARCH 25, 2008	L. 2916 P. 728	12.0	18.00-3-23, 18.00-3-24.1 & 18.00-3-26
257	PAUL C. & NANCY RUSSELL	ALBANY COUNTY AIRPORT AUTHORITY	MAY 8, 2008	L. 2919 P. 836	7.8	08.03-1-58.2 (PORTION OF FORMER 08.03-1-58)
258	ALBANY COUNTY AIRPORT AUTHORITY	PAUL C. & NANCY RUSSELL	MAY 5, 2008	L. 2919 P. 717	8.4	08.03-1-58.1 (FORMERLY 08.03-1-59)
259	ALBANY COUNTY AIRPORT AUTHORITY	PAUL C. & NANCY RUSSELL	MAY 5, 2008	L. 2919 P. 717	1.1	08.03-1-58.1 (FORMERLY 08.03-1-11)
260E	PAUL C. & NANCY RUSSELL	ALBANY COUNTY AIRPORT AUTHORITY	MAY 8, 2008	L. 2919 P. 754	16.7	08.03-1-58.1/AVIGATION EASEMENT
261E	WINN LTD. - MARK FLEISCHER, G.M.	ALBANY COUNTY AIRPORT AUTHORITY	---	---	4.0	18.00-1-43.32/AVIGATION EASEMENT(PROPOSED)
262E	BRITISH AMERICAN, LLC	ALBANY COUNTY AIRPORT AUTHORITY	---	---	42.8	18.00-1-43.31/AVIGATION EASEMENT(PROPOSED)
263E	SHAKER RIDGE COUNTRY CLUB, INC.	ALBANY COUNTY AIRPORT AUTHORITY	---	---	170.6	18.00-1-43.1/AVIGATION EASEMENT(PROPOSED)
264E	ROSEWOOD SHAKER RIDGE, LLC	ALBANY COUNTY AIRPORT AUTHORITY	---	---	17.3	18.00-1-43.23/AVIGATION EASEMENT(PROPOSED)
265E	BRITISH AMERICAN, LLC	ALBANY COUNTY AIRPORT AUTHORITY	---	---	11.0	18.00-1-43.21/AVIGATION EASEMENT(PROPOSED)
266E	MEMORY GARDENS, INC.	ALBANY COUNTY AIRPORT AUTHORITY	---	---	194.3	18.00-1-44/AVIGATION EASEMENT(PROPOSED)
267E	BOCES	ALBANY COUNTY AIRPORT AUTHORITY	---	---	12.9	30.00-1-1/AVIGATION EASEMENT(PROPOSED)
268E	JOSEPH H. & FRANCES A. SCHMIDT	ALBANY COUNTY AIRPORT AUTHORITY	---	---	1.31	17.04-2-9/AVIGATION EASEMENT(PROPOSED)
269E	SUSAN A. LANZA	ALBANY COUNTY AIRPORT AUTHORITY	---	---	0.8	17.04-2-10/AVIGATION EASEMENT(PROPOSED)
270E	MICHAEL S. CERONE	ALBANY COUNTY AIRPORT AUTHORITY	---	---	0.7	17.04-2-17.1/AVIGATION EASEMENT(PROPOSED)
271E	MARIA A. GPOAL SISTLA	ALBANY COUNTY AIRPORT AUTHORITY	---	---	0.3	17.04-2-18/AVIGATION EASEMENT(PROPOSED)
272E	JOHN G. POTYRALA, JR.	ALBANY COUNTY AIRPORT AUTHORITY	---	---	0.4	17.04-2-19/AVIGATION EASEMENT(PROPOSED)
273E	LEONARD F. & FRANCES G. IVESON	ALBANY COUNTY AIRPORT AUTHORITY	---	---	0.4	17.04-2-20/AVIGATION EASEMENT(PROPOSED)
274E	WILLIAM J. & JEANNE B. KELLEY	ALBANY COUNTY AIRPORT AUTHORITY	---	---	0.4	17.04-2-21/AVIGATION EASEMENT(PROPOSED)
275E	STEPHEN & BARBARA QUAY	ALBANY COUNTY AIRPORT AUTHORITY	---	---	0.4	17.04-2-22/AVIGATION EASEMENT(PROPOSED)
276E	ANNE P. GALLOWAY & PETER E. PALMER	ALBANY COUNTY AIRPORT AUTHORITY	---	---	2.9	17.04-2-33.1/AVIGATION EASEMENT(PROPOSED)
277E	MICHAEL M. MASTROPIETRO	ALBANY COUNTY AIRPORT AUTHORITY	---	---	0.4	17.04-2-45/AVIGATION EASEMENT(PROPOSED)
278E	RONALD T. & SHIRLEY NEWTON PHILLIPS	ALBANY COUNTY AIRPORT AUTHORITY	---	---	0.4	17.04-2-48/AVIGATION EASEMENT(PROPOSED)
279E	GREGORY G. & KATHLEEN M. CHUDZINSKI	ALBANY COUNTY AIRPORT AUTHORITY	---	---	0.3	17.04-2-49/AVIGATION EASEMENT(PROPOSED)
280E	CRAIG & BARBARA PAULSEN AND EVELYN POWERS	ALBANY COUNTY AIRPORT AUTHORITY	---	---	0.4	17.04-10-15/AVIGATION EASEMENT(PROPOSED)
281E	PATRICK J. BCOLOGNA	ALBANY COUNTY AIRPORT AUTHORITY	---	---	0.8	17.04-10-16/AVIGATION EASEMENT(PROPOSED)

NOTE:

THIS MAP AND LAND INVENTORY DEED TABULATION REPRESENTS A COMPILATION OF LANDS, PARCELS AND PROPERTIES OF THE ALBANY COUNTY AIRPORT AUTHORITY PREPARED FROM DEEDS OF RECORD, LAND SURVEY MAPS, LAND LEASE DOCUMENTS, HIGHWAY RIGHT-OF-WAY MAPS, AND OTHER LAND RECORD SOURCES PROVIDED TO L. SIPPERLY & ASSOCIATES, D.P.C.



L. SIPPERLY & ASSOCIATES, D.P.C.
ENGINEERS • SURVEYORS • LAND PLANNERS

AIRPORT PROPERTY MAP
EXHIBIT "A" - SHEET 12
LAND TABULATION

ALBANY COUNTY AIRPORT AUTHORITY
ALBANY, NEW YORK

LAST REVISED: 1/31/19

DATE: 1/31/19 DEEDS BY: ESTIMATED BY: DRAWN BY: CHECKED BY:

PARCEL NO.	GRANTOR	GRANTEE	DEED DATE	RECORDED	AREA (AC. +/-)	REMARKS
282E	TERRENCE W. & BARBARA J. SHIELDS	ALBANY COUNTY AIRPORT AUTHORITY	---	---	0.5	17.04-10-17/AVIGATION EASEMENT(PROPOSED)
283E	MARK A. & ROBIN J. GREENE	ALBANY COUNTY AIRPORT AUTHORITY	---	---	0.4	17.04-10-18/AVIGATION EASEMENT(PROPOSED)
284E	MORINAGA & KIYOMI KAZUNOBO	ALBANY COUNTY AIRPORT AUTHORITY	---	---	0.4	17.04-10-19/AVIGATION EASEMENT(PROPOSED)
285E	JAMES R., Jr. & MAUREEN A. KELLY	ALBANY COUNTY AIRPORT AUTHORITY	---	---	0.4	17.04-10-23/AVIGATION EASEMENT(PROPOSED)
286E	RONALD E. RANELUCCI & MARY C. BARTON	ALBANY COUNTY AIRPORT AUTHORITY	---	---	0.4	17.04-10-23/AVIGATION EASEMENT(PROPOSED)
287E	LUIGI & MARIA S. DENITTO	ALBANY COUNTY AIRPORT AUTHORITY	---	---	0.5	17.04-10-25/AVIGATION EASEMENT(PROPOSED)
288E	CHARLES DAVID & ROSEMARIE S. SCRODANOUS	ALBANY COUNTY AIRPORT AUTHORITY	---	---	0.8	17.04-10-26/AVIGATION EASEMENT(PROPOSED)
289E	FRED C. SPAGNOLA & MARY C. ZOBIE	ALBANY COUNTY AIRPORT AUTHORITY	---	---	0.6	17.04-10-27/AVIGATION EASEMENT(PROPOSED)
290E	PATRICIA E. FUSCO	ALBANY COUNTY AIRPORT AUTHORITY	---	---	0.4	17.04-10-28/AVIGATION EASEMENT(PROPOSED)
291	SHAKER RIDGE COUNTRY CLUB, INC.	ALBANY COUNTY AIRPORT AUTHORITY	OCT. 3, 2008	L. 2933 P. 599	4.2	18.00-1-43.4
292E	COUNTY OF ALBANY	ALBANY COUNTY AIRPORT AUTHORITY	FEB. 17, 2005	L. 2919 P. 541	---	SANITARY SEWER EASEMENT(ANN LEE HOME)
293	GUPTILL HOLDING CORPORATION	ALBANY COUNTY AIRPORT AUTHORITY	JUNE 5, 2008	L. 2932 P. 786	0.8	19.03-1-30
294	ALBANY CO. DEPT. OF MANAGEMENT & BUDGET	ALBANY COUNTY AIRPORT AUTHORITY	FEB. 28, 2011	L. 3003 P. 858	--	30.00-5-3/696 ALBANY SHAKER ROAD
295	698 SHAKER ROAD LLC & MALA PROPERTIES INC.	ALBANY COUNTY AIRPORT AUTHORITY	MAY 24, 2011	L. 3006 P. 67	0.2	30.00-5-2/698 ALBANY SHAKER ROAD
296	JEFFREY BUHRMASTER	ALBANY COUNTY AIRPORT AUTHORITY	FEB. 23, 2011	L. 2999 P. 1008	1.8	08.03-1-66/9 BUHRMASTER ROAD
297	GEORGE F. BUHRMASTER	ALBANY COUNTY AIRPORT AUTHORITY	MARCH 4, 2011	L. 3002 P. 401	1.4	08.03-1-65/15 BUHRMASTER ROAD (WITH LIFE ESTATE) CORRECTIVE DEED L. 3039, P. 558
298	GEORGE E. LONGHURST	ALBANY COUNTY AIRPORT AUTHORITY	---	---	1.4	08.03-1-62/29 BUHRMASTER ROAD (PENDING NOISE ACQUISITION)
299	PAUL & JEANNE PEZZULO	ALBANY COUNTY AIRPORT AUTHORITY	---	---	2.3	08.03-1-61/27 BUHRMASTER ROAD (PENDING NOISE ACQUISITION)
300	STANLEY B. & PATRICIA A. HICKS	ALBANY COUNTY AIRPORT AUTHORITY	---	---	--	18.00-3-19/6 KELLY ROAD (PENDING NOISE ACQUISITION)
301	GEORGE F. & JEFFREY G. BUHRMASTER	ALBANY COUNTY AIRPORT AUTHORITY	MARCH 29, 2011	L. 3002 P. 396	11.4	PORTION OF 08.04-1-52.1/4120 RIVER ROAD
302	FREDERICK P. & YVONNE L. SYNDER	ALBANY COUNTY AIRPORT AUTHORITY	---	---	--	18.00-2-41.1/42 SICKER ROAD (PENDING NOISE ACQUISITION)
303	MARGARET K. GIBSON, ET. AL	ALBANY COUNTY AIRPORT AUTHORITY	FEB. 12, 2010	L. 2971 P. 862	1.9	18.00-2-11/1060 TROY-SCHENECTADY ROAD
304	JOHN K. ENGEL & EDWARD W. ENGEL, III	ALBANY COUNTY AIRPORT AUTHORITY	NOV. 5, 2009	L. 2963 P. 352	44.4	30.00-5-1/682 ALBANY-SHAKER ROAD
305E	MEMORY GARDENS, INC.	ALBANY COUNTY AIRPORT AUTHORITY	NOV. 24, 2010	L. 2993 P. 819	59.2	PORTION OF 18.00-1-44/AVIGATION EASEMENT
306L	ALBANY COUNTY AIRPORT AUTHORITY	CELLCO PARTNERSHIP	NOV. 29, 2010	L. 3000 P. 563	---	LEASE AGREEMENT - WITHIN TERMINAL BUILDING
307	ALBANY COUNTY AIRPORT AUTHORITY	JEFFREY G. & CHRISTINE BUHRMASTER	MARCH 28, 2011	L. 3002 P. 255	---	PORTION OF 8.03-1-63
308E	GEORGE & JEFFREY BUHRMASTER	ALBANY COUNTY AIRPORT AUTHORITY	MARCH 4, 2011	L. 3002 P. 390	19.3	PORTION OF 8.04-1-52.1/AVIGATION EASEMENT
309	TOWN OF COLONIE	ALBANY COUNTY AIRPORT AUTHORITY	AUG. 11, 2011	L. 3012 P. 808	1.9	19.14-3-10/25 UTICA AVENUE
310CE	ALBANY COUNTY AIRPORT AUTHORITY	TOWN OF COLONIE	AUG. 11, 2011	L. 3012 P. 808	1.9	19.14-3-10/25 UTICA AVENUE/UTILITY EASEMENT
311	ALBANY COUNTY AIRPORT AUTHORITY	388 OLD NISKAYUNA ROAD LLC	OCT. 31, 2011	L. 3018 P. 159	2.5	18.00-3-51 & 48/388 OLD NISKAYUNA ROAD & 172 SICKER ROAD
312E	388 OLD NISKAYUNA ROAD LLC	ALBANY COUNTY AIRPORT AUTHORITY	OCT. 31, 2011	L. 3018 P. 159	2.5	18.00-3-51 & 48/AVIGATION EASEMENT
313E	JOHN K. ENGEL & EDWARD W. ENGEL, III	ALBANY COUNTY AIRPORT AUTHORITY	DEC. 18, 2013	L. 3086 P. 1000	38.46	30.00-3-77/AVIGATION EASEMENT
314	LATHAM POOL PRODUCTS, INC	ALBANY COUNTY AIRPORT AUTHORITY	FEB. 3, 2017	INST. R2017-3682	2.226	PORTION OF 30.00-3-13.1 (SEE FOLLOWING NOTE)
NOTE	ALBANY COUNTY AIRPORT AUTHORITY	ALBANY COUNTY AIRPORT AUTHORITY	FEB 6, 2017	INST. R2017-3683	12.28	PARCEL 314 MERGED WITH PARCEL 220 AND DESIGNATED AS TMLP 30.00-3-13.1
315L	COUNTY OF ALBANY	ALBANY COUNTY AIRPORT AUTHORITY	APRIL 12, 2017	COUNTY RESOLUTION	3.49	LAND LEASE AMENDMENT NO. 6-SE CORNER - INTERSECTION OF HERITAGE LANE & PETER J. DALESSONDRO BLVD.
316	ALBANY COUNTY AIRPORT AUTHORITY	N.Y.S. DEPARTMENT OF TRANSPORTATION	MARCH 26, 2018		5.911	NOTICE OF APPROPRIATION - MAP NO. 755 R-1, PARCEL NO. 881 RESERVES PRIOR AVIGATION EASEMENT OVER LANDS
317	ALBANY COUNTY AIRPORT AUTHORITY	N.Y.S. DEPARTMENT OF TRANSPORTATION	MARCH 26, 2018		6.061	NOTICE OF APPROPRIATION - MAP NO. 765 R-1, PARCEL NO. 892 RESERVES PRIOR AVIGATION EASEMENT OVER LANDS
318E	THE PEOPLE OF THE STATE OF NEW YORK	ALBANY COUNTY AIRPORT AUTHORITY	OCT. 11, 2018	INST. R2018-25900	---	PORTION OF 30.00-5-10.2/AVIGATION EASEMENT IN MAP NO. 768-C PARCEL NO. 895
319E	THE PEOPLE OF THE STATE OF NEW YORK	ALBANY COUNTY AIRPORT AUTHORITY	OCT. 11, 2018	INST. R2018-25901	---	PORTION OF 30.00-5-4/AVIGATION EASEMENT IN MAP NO. 749-C PARCEL NO. 875

NOTE:

THIS MAP AND LAND INVENTORY DEED TABULATION REPRESENTS A COMPILATION OF LANDS, PARCELS AND PROPERTIES OF THE ALBANY COUNTY AIRPORT AUTHORITY PREPARED FROM DEEDS OF RECORD, LAND SURVEY MAPS, LAND LEASE DOCUMENTS, HIGHWAY RIGHT-OF-WAY MAPS, AND OTHER LAND RECORD SOURCES PROVIDED TO L. SIPPERLY & ASSOCIATES, DPC.



L. SIPPERLY & ASSOCIATES, D.P.C.
ENGINEERS • SURVEYORS • LAND PLANNERS

AIRPORT PROPERTY MAP
EXHIBIT "A" - SHEET 13
LAND TABULATION

ALBANY COUNTY AIRPORT AUTHORITY
ALBANY, NEW YORK

LAST REVISED: 1/31/19

DATE: _____ DECEDED BY: _____ DRAWN BY: _____ ESTIMATED BY: _____ CHECKED BY: _____

AGENDA ITEM NO. 13.2

**Federal/State Grant: Acceptance of Federal
Airport Improvement Program
Grant #3-36-0001-142-2020; Replace
Boarding Bridge A3, A5, B10, and C1; Remove OTW
Bridge C2 and C3; Design and Construction;
Phase 4 of 6**

AGENDA ITEM NO: 13.2
MEETING DATE: June 8, 2020

ALBANY COUNTY AIRPORT AUTHORITY
REQUEST FOR AUTHORIZATION

ACAA Approved
06/08/2020

DEPARTMENT: *Planning and Engineering*

Contact Person: *Stephen Iachetta, AICP, Airport Planner*

PURPOSE OF REQUEST:

Federal/State Grant: *Acceptance of Federal Airport Improvement Program Grant #3-36-0001-142-2020; Replace Boarding Bridge A3, A5, B10, and C1; Remove OTW Bridge C2 and C3; Design and Construction; Phase 4 of 6*

CONTRACT AMOUNT: Funding Share Allocations

\$ 3,140,730	Federal Aviation Administration (90%)
0	State
<u>348,970</u>	Federal CARES Act (10%)
\$ 3,489,700	Total

BUDGET INFORMATION:

Anticipated in Current Capital Plan: Yes J No ___ NA ___
Funding Account No: CPN 2245

FISCAL IMPACT - FUNDING (Dollars or Percentages)

Federal 90% State 0% CARES Act Airport 10% NA ___
Funding Source: *Airport Improvement Program*;
Term of Funding: August 2020 through 2022
Grant No.: 3-36-0001-142-2020;

JUSTIFICATION:

Authorization is requested to accept Airport Improvement Program grant 3-36-0001-142-2020 to establish funding in the 90% Federal Aviation Administration and 10% CARES Act share allocations noted above with a total budget of \$3,489,700 to support Contracts S-1039; 1039-GC and 1039-E . Conformance with applicable Federal regulatory requirements has been reviewed and confirmed with the Federal Aviation Administration to assure ongoing AIP program compliance.

CHIEF EXECUTIVE OFFICER'S RECOMMENDATION:

Recommend approval.

AGENDA ITEM NO: 13.2
MEETING DATE: **June 8, 2020**

FINAL AGREEMENT SUBJECT TO APPROVAL BY COUNSEL: YES NA

PROCUREMENT DEPARTMENT APPROVAL:

Procurement complies with Authority Procurement Guidelines and Chief Financial Officer has approved. YES NA

BACK-UP MATERIAL:

Please refer to the attached FAA Grant Application.

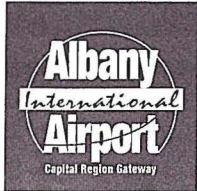

ALBANY COUNTY AIRPORT AUTHORITY
ALBANY INTERNATIONAL AIRPORT
ADMINISTRATION BUILDING
SUITE 200
ALBANY, NEW YORK 12211-1057

TEL: 518.242.2222
ADMIN FAX: 518.242.2641
FINANCE FAX: 518.242.2640
SITE: www.albanyairport.com

June 2, 2020

Ms. Evelyn Martinez, Manager
New York Airports District Office
One Aviation Plaza, Suite 111
Jamaica, New York 11434

Attention: Ralph Gatto, Airport Engineer

**RE: Airport Improvement Project Application and Request for Grant Issuance;
AIP No. 3-36-0001-142-2020; Replace Passenger Boarding Bridge A3, A5, B10 and
C1; Remove OTW Bridge C2 and C3, Design and Construction; Phase 4 of 6**

Dear Ms. Martinez,

I am writing to respectfully request your review and concurrence for issuance of the above referenced Airport Improvement Program grant offer to support a passenger/cargo entitlement allocation of \$3,140,730 as the ninety percent Federal share AIP grant basis as programmed among our respective staff. Enclosed please find one original signed copy of the executed final application package pursuant to the current Airport Sponsors Guide.

Please note that the Environmental Categorical Exclusion (FONSI-ROD), A-95 Congressional clearance and local coordination for this project has been completed as noted in the attached confirming documents. Airport Layout Plan Review is not applicable for this project. 7460-1 air space review has been submitted for proposed temporary construction equipment. This project is designed to preserve and enhance airport safety and capacity.

Thank you for your ongoing cooperation and assistance with this important airport safety and capacity improvement project at Albany International Airport. Please do not hesitate to call Airport Planner, Steve Iachetta of my staff at (518) 242-2238 if you require any additional information.

Sincerely,



Philip F. Calderone, Esq
Chief Executive Officer

PFC/ela
Enclosure

cc: Lowell Lingo, NYSDOT-MO Aviation Bureau
Michael Zonsius, Chief Finance Officer
John LaClair, Airport Engineer
Steve Iachetta, Airport Planner

Application for Federal Assistance SF-424

* 1. Type of Submission:

- Preapplication
 Application
 Changed/Corrected Application

* 2. Type of Application:

- New
 Continuation
 Revision

* If Revision, select appropriate letter(s):

* Other (Specify):

* 3. Date Received:

06/02/2020

4. Applicant Identifier:

ALB

5a. Federal Entity Identifier:

3-36-0001-142-2020

5b. Federal Award Identifier:

State Use Only:

6. Date Received by State:

06/02/2020

7. State Application Identifier:

NA

8. APPLICANT INFORMATION:

* a. Legal Name:

Albany County Airport Authority

* b. Employer/Taxpayer Identification Number (EIN/TIN):

14-1768979

* c. Organizational DUNS:

1457016990000

d. Address:

* Street1:

737 Albany Shaker Road

Street2:

Authority Administration Bldg; 2nd Floor

* City:

Albany

County/Parish:

Albany

* State:

NY: New York

Province:

* Country:

USA: UNITED STATES

* Zip / Postal Code:

12211-1057

e. Organizational Unit:

Department Name:

Executive

Division Name:

f. Name and contact information of person to be contacted on matters involving this application:

Prefix:

* First Name:

Philip

Middle Name:

F.

* Last Name:

Calderone

Suffix:

Esq.

Title:

Chief Executive Officer

Organizational Affiliation:

Albany County Airport Authority

* Telephone Number:

518-242-2222

Fax Number:

518-242-2641

* Email:

pCalderone@albanyairport.com

Application for Federal Assistance SF-424

*** 9. Type of Applicant 1: Select Applicant Type:**

B: County Government

Type of Applicant 2: Select Applicant Type:

Type of Applicant 3: Select Applicant Type:

* Other (specify):

*** 10. Name of Federal Agency:**

Federal Aviation Administration

11. Catalog of Federal Domestic Assistance Number:

20.106

CFDA Title:

*** 12. Funding Opportunity Number:**

NA

* Title:

NA

13. Competition Identification Number:

NA

Title:

NA

14. Areas Affected by Project (Cities, Counties, States, etc.):

Add Attachment

Delete Attachment

View Attachment

*** 15. Descriptive Title of Applicant's Project:**

Replace Passenger Boarding Bridge A3, A5, B10, and C1; Remove OTW Birdge C2 and C3; Design and Construction; Phase 4 of 6

Attach supporting documents as specified in agency instructions.

Add Attachments

Delete Attachments

View Attachments

Application for Federal Assistance SF-424

16. Congressional Districts Of:

* a. Applicant

* b. Program/Project

Attach an additional list of Program/Project Congressional Districts if needed.

17. Proposed Project:

* a. Start Date:

* b. End Date:

18. Estimated Funding (\$):

* a. Federal	<input type="text" value="3,140,730.00"/>
* b. Applicant	<input type="text" value="0.00"/>
* c. State	<input type="text" value="0.00"/>
* d. Local	<input type="text" value="0.00"/>
* e. Other	<input type="text" value="348,970.00"/>
* f. Program Income	<input type="text" value="0.00"/>
* g. TOTAL	<input type="text" value="3,489,700.00"/>

*** 19. Is Application Subject to Review By State Under Executive Order 12372 Process?**

- a. This application was made available to the State under the Executive Order 12372 Process for review on
- b. Program is subject to E.O. 12372 but has not been selected by the State for review.
- c. Program is not covered by E.O. 12372.

*** 20. Is the Applicant Delinquent On Any Federal Debt? (If "Yes," provide explanation in attachment.)**

- Yes
- No

If "Yes", provide explanation and attach

21. *By signing this application, I certify (1) to the statements contained in the list of certifications and (2) that the statements herein are true, complete and accurate to the best of my knowledge. I also provide the required assurances** and agree to comply with any resulting terms if I accept an award. I am aware that any false, fictitious, or fraudulent statements or claims may subject me to criminal, civil, or administrative penalties. (U.S. Code, Title 218, Section 1001)**

** I AGREE

** The list of certifications and assurances, or an internet site where you may obtain this list, is contained in the announcement or agency specific instructions.

Authorized Representative:

Prefix: * First Name:
Middle Name:
* Last Name:
Suffix:

* Title:

* Telephone Number: Fax Number:

* Email:

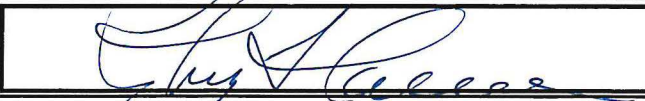
* Signature of Authorized Representative: 

* Date Signed:

Application for Federal Assistance (Development and Equipment Projects)

PART II – PROJECT APPROVAL INFORMATION

Part II - SECTION A	
The term "Sponsor" refers to the applicant name provided in box 8 of the associated SF-424 form.	
Item 1. Does Sponsor maintain an active registration in the System for Award Management (www.SAM.gov)?	<input checked="" type="checkbox"/> Yes <input type="checkbox"/> No
Item 2. Can Sponsor commence the work identified in the application in the fiscal year the grant is made or within six months after the grant is made, whichever is later?	<input checked="" type="checkbox"/> Yes <input type="checkbox"/> No <input type="checkbox"/> N/A
Item 3. Are there any foreseeable events that would delay completion of the project? If yes, provide attachment to this form that lists the events.	<input type="checkbox"/> Yes <input checked="" type="checkbox"/> No <input type="checkbox"/> N/A
Item 4. Will the project(s) covered by this request have impacts or effects on the environment that require mitigating measures? If yes, attach a summary listing of mitigating measures to this application and identify the name and date of the environmental document(s).	<input type="checkbox"/> Yes <input checked="" type="checkbox"/> No <input type="checkbox"/> N/A
Item 5. Is the project covered by this request included in an approved Passenger Facility Charge (PFC) application or other Federal assistance program? If yes, please identify other funding sources by checking all applicable boxes.	<input type="checkbox"/> Yes <input checked="" type="checkbox"/> No <input type="checkbox"/> N/A
<input type="checkbox"/> The project is included in an <i>approved</i> PFC application. If included in an approved PFC application, does the application <i>only</i> address AIP matching share? <input type="checkbox"/> Yes <input type="checkbox"/> No	
<input type="checkbox"/> The project is included in another Federal Assistance program. Its CFDA number is below.	
Item 6. Will the requested Federal assistance include Sponsor indirect costs as described in 2 CFR Appendix VII to Part 200, States and Local Government and Indian Tribe Indirect Cost Proposals?	<input type="checkbox"/> Yes <input checked="" type="checkbox"/> No <input type="checkbox"/> N/A
If the request for Federal assistance includes a claim for allowable indirect costs, select the applicable indirect cost rate the Sponsor proposes to apply:	
<input type="checkbox"/> De Minimis rate of 10% as permitted by 2 CFR § 200.414.	
<input type="checkbox"/> Negotiated Rate equal to % as approved by (the Cognizant Agency) on (Date) (2 CFR part 200, appendix VII).	
<i>Note: Refer to the instructions for limitations of application associated with claiming Sponsor indirect costs.</i>	

PART II - SECTION B

Certification Regarding Lobbying

The declarations made on this page are under the signature of the authorized representative as identified in box 21 of form SF-424, to which this form is attached. The term "Sponsor" refers to the applicant name provided in box 8 of the associated SF-424 form.

The Authorized Representative certifies, to the best of his or her knowledge and belief, that:

(1) No Federal appropriated funds have been paid or will be paid, by or on behalf of the Sponsor, to any person for influencing or attempting to influence an officer or employee of an agency, a Member of Congress, an officer or employee of Congress, or an employee of a Member of Congress in connection with the awarding of any Federal contract, the making of any Federal grant, the making of any Federal loan, the entering into of any cooperative agreement, and the extension, continuation, renewal, amendment, or modification of any Federal contract, grant, loan, or cooperative agreement.

(2) If any funds other than Federal appropriated funds have been paid or will be paid to any person for influencing or attempting to influence an officer or employee of any agency, a Member of Congress, an officer or employee of Congress, or an employee of a Member of Congress in connection with this Federal contract, grant, loan, or cooperative agreement, the Authorized Representative shall complete and submit Standard Form-LLL, "Disclosure Form to Report Lobbying," in accordance with its instructions.

(3) The Authorized Representative shall require that the language of this certification be included in the award documents for all sub-awards at all tiers (including subcontracts, subgrants, and contracts under grants, loans, and cooperative agreements) and that all subrecipients shall certify and disclose accordingly.

This certification is a material representation of fact upon which reliance was placed when this transaction was made or entered into. Submission of this certification is a prerequisite for making or entering into this transaction imposed by section 1352, title 31, U.S. Code. Any person who fails to file the required certification shall be subject to a civil penalty of not less than \$10,000 and not more than \$100,000 for each such failure.

PART II – SECTION C

The Sponsor hereby represents and certifies as follows:

1. Compatible Land Use – The Sponsor has taken the following actions to assure compatible usage of land adjacent to or in the vicinity of the airport:

ALB Airport is situated in the center of the Town of Colonie and the Town Comprehensive Plan includes an Airport Noise Compatibility Zone, Airport Business District and appropriate local land-use regulations to assure ongoing Airport land use compatibility.

2. Defaults – The Sponsor is not in default on any obligation to the United States or any agency of the United States Government relative to the development, operation, or maintenance of any airport, except as stated herewith:

Confirmed.

3. Possible Disabilities – There are no facts or circumstances (including the existence of effective or proposed leases, use agreements or other legal instruments affecting use of the Airport or the existence of pending litigation or other legal proceedings) which in reasonable probability might make it impossible for the Sponsor to carry out and complete the Project or carry out the provisions of the Grant Assurances, either by limiting its legal or financial ability or otherwise, except as follows:

Confirmed.

4. Consistency with Local Plans – The project is reasonably consistent with plans existing at the time of submission of this application) of public agencies that are authorized by the State in which the project is located to plan for the development of the area surrounding the airport.

Confirmed.

5. Consideration of Local Interest – It has given fair consideration to the interest of communities in or near where the project may be located.

Confirmed.

6. Consultation with Users – In making a decision to undertake an airport development project under Title 49, United States Code, it has consulted with airport users that will potentially be affected by the project (§ 47105(a)(2)).

Confirmed.

7. Public Hearings – In projects involving the location of an airport, an airport runway or a major runway extension, it has afforded the opportunity for public hearings for the purpose of considering the economic, social, and environmental effects of the airport or runway location and its consistency with goals and objectives of such planning as has been carried out by the community and it shall, when requested by the Secretary, submit a copy of the transcript of such hearings to the Secretary. Further, for such projects, it has on its management board either voting representation from the communities where the project is located or has advised the communities that they have the right to petition the Secretary concerning a proposed project.

Not applicable.

8. Air and Water Quality Standards – In projects involving airport location, a major runway extension, or runway location it will provide for the Governor of the state in which the project is located to certify in writing to the Secretary that the project will be located, designed, constructed, and operated so as to comply with applicable and air and water quality standards. In any case where such standards have not been approved and where applicable air and water quality standards have been promulgated by the Administrator of the Environmental Protection Agency, certification shall be obtained from such Administrator. Notice of certification or refusal to certify shall be provided within sixty days after the project application has been received by the Secretary.

Not applicable.

PART II – SECTION C (Continued)

9. Exclusive Rights – There is no grant of an exclusive right for the conduct of any aeronautical activity at any airport owned or controlled by the Sponsor except as follows:

Confirmed.

10. Land – (a) The sponsor holds the following property interest in the following areas of land, which are to be developed or used as part of or in connection with the Airport subject to the following exceptions, encumbrances, and adverse interests, all of which areas are identified on the aforementioned property map designated as Exhibit "A". [1]

Confirmed.

The Sponsor further certifies that the above is based on a title examination by a qualified attorney or title company and that such attorney or title company has determined that the Sponsor holds the above property interests.

(b) The Sponsor will acquire within a reasonable time, but in any event prior to the start of any construction work under the Project, the following property interest in the following areas of land on which such construction work is to be performed, all of which areas are identified on the aforementioned property map designated as Exhibit "A". [1]

Confirmed.

(c) The Sponsor will acquire within a reasonable time, and if feasible prior to the completion of all construction work under the Project, the following property interest in the following areas of land which are to be developed or used as part of or in connection with the Airport as it will be upon completion of the Project, all of which areas are identified on the aforementioned property map designated as Exhibit "A". [1]

Not applicable.

¹ State the character of property interest in each area and list and identify for each all exceptions, encumbrances, and adverse interests of every kind and nature, including liens, easements, leases, etc. The separate areas of land need only be identified here by the area numbers shown on the property map.

PART III – BUDGET INFORMATION – CONSTRUCTION

SECTION A – GENERAL	
1. Federal Domestic Assistance Catalog Number: 20-106 Airport Improvement Program	
2. Functional or Other Breakout:	3-36-0001-142-2020

SECTION B – CALCULATION OF FEDERAL GRANT			
Cost Classification	Latest Approved Amount (Use only for revisions)	Adjustment + or (-) Amount (Use only for revisions)	Total Amount Required
1. Administration expense			
2. Preliminary expense	750		750
3. Land, structures, right-of-way			
4. Architectural engineering basic fees	144,950		144,950
5. Other Architectural engineering fees			
6. Project inspection fees	130,000		130,000
7. Land development			
8. Relocation Expenses			
9. Relocation payments to Individuals and Businesses			
10. Demolition and removal			
11. Construction and project improvement	3,214,000		3,214,000
12. Equipment			
13. Miscellaneous			
14. Subtotal (Lines 1 through 13)			
15. Estimated Income (if applicable)			
16. Net Project Amount (Line 14 minus 15)			
17. Less: Ineligible Exclusions (Section C, line 23 g.)			
18. Subtotal (Lines 16 through 17)	\$ 3,489,700		\$ 3,489,700
19. Federal Share requested of Line 18	3,140,730		3,140,730
20. Grantee share			
21. Other shares	348,970		348,970
22. TOTAL PROJECT (Lines 19, 20 & 21)	\$ 3,489,700		\$ 3,489,700

SECTION C – EXCLUSIONS	
23. Classification (Description of non-participating work)	Amount Ineligible for Participation
a.	
b.	
c.	
d.	
e.	
f.	
g. Total	

SECTION D – PROPOSED METHOD OF FINANCING NON-FEDERAL SHARE	
24. Grantee Share – Fund Categories	Amount
a. Securities	
b. Mortgages	
c. Appropriations (by Applicant)	
d. Bonds	
e. Tax Levies	
f. Non-Cash	
g. Other (Explain):	
h. TOTAL - Grantee share	
25. Other Shares	Amount
a. State	
b. Other	
c. TOTAL - Other Shares	\$ 348,970
26. TOTAL NON-FEDERAL FINANCING	

SECTION E – REMARKS (Attach sheets if additional space is required)
<p>AIP Entitlement comprises 90% and CARES Act comprises 10% of the as-bid program budget.</p>

PART IV – PROGRAM NARRATIVE
(Suggested Format)

PROJECT: 3-36-0001-142-2020 Replace Passenger Boarding Bridges Design and Construction Phase 4 of 6

AIRPORT: ALB- Albany International Airport

1. Objective:

Assure continuous safety and capacity for terminal passenger boarding through removal and replacement of Passenger Boarding Bridge A3, A5, B10, and C1 and removal of Over-the Wing Boarding Bridge C2 and C3. This comprises phase 4 of six programmed bridge projects over the planning period.

2. Benefits Anticipated:

Existing bridges are over twenty-years old and beyond efficient functional utility. Energy efficiency and code compliance will be assured through scheduled replacement.

3. Approach: (See approved Scope of Work in Final Application)

Passenger Boarding Bridge replacement will proceed in the order listed as coordinated with Airport Operations and FAA. Only one PBB will be progressed at a time.

4. Geographic Location:

The Terminal project site location aerial image with notations is attached.

5. If Applicable, Provide Additional Information:

6. Sponsor's Representative: (include address & telephone number)

Philip F. Calderone, Esq.; Chief Executive Officer; Albany County Airpor Authority; Adminsitration Bldg.;
737 Albany Shaker Road; Albany, NY 12211-1057; Telephone 518-242-2222

CONTRACT #1039-GC

Replacement of Passenger Boarding Bridges A3, A5, B10 & C1 - Phase 4

Company Name	AeroBridge	Oxford Engineering	VRH Jetworks
Addendum #1	X	X	X
Addendum #2	X	X	X
Addendum #3	X	X	X
Addendum #4	X	X	X
Addendum #5	X	X	X
Lump Sum Bid	\$2,520,000.00	\$2,937,853.00	\$3,457,000.00
Bid Bond	5%	5%	5%
Board of Directors	X	Corporate Acknowledgment	X
Non-Collusion	X	X	X
Qualification Questionnaire	X	X	X
Acknowledgment	X	X	X

I, Kathryn Kane, certify that this bid tabulation is a true copy of the prices submitted by each bidder for the construction project shown above.

Albany Airport Authority Purchasing Department



Kathryn Kane
Deputy Purchasing Agent

Sworn to before me this 2nd day of June 2020.

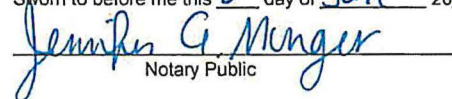
Notary Public

JENNIFER A. MUNGER
Notary Public, State of New York
No. 01MU6246332
Qualified in Schenectady County
Commission Expires Aug. 08, 2023

CONTRACT #1039-E

Replacement of Passenger Boarding Bridges A3, A5, B10 & C1 - Phase 4

Company Name	AeroBridge Works Inc.	Kasselman Electric Co.	Oxford Engineering
Addendum #1	X	X	X
Addendum #2	X	X	X
Addendum #3	X	X	X
Addendum #4	X	X	X
Addendum #5	X	X	X
Lump Sum Bid	\$694,000.00	\$1,097,981.00	\$810,106.00
Bid Bond	5%	Check	5%
Board of Directors	X	X	Corporate Acknowledgment
Non-Collusion	X	X	X
Qualification Questionnaire	X	X	X
Acknowledgment	X	X	X

I, Kathryn Kane, certify that this bid tabulation is a true copy of the prices submitted by each bidder for the construction project shown above.

Albany Airport Authority Purchasing Department

 Kathryn Kane
 Deputy Purchasing Agent

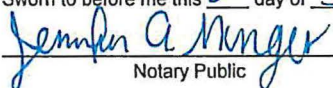
Sworn to before me this 2nd day of June 2020

 Notary Public

JENNIFER A. MUNGER
 Notary Public, State of New York
 No. 01MU6246332
 Qualified in Schenectady County
 Commission Expires Aug. 08, 2023

PASSENGER BOARDING BRIDGE IMPROVEMENT PROJECT – PHASE IV

Airfield Information

- Will require up to 120 foot high crane at PBB replacement locations
- Individual gates will be closed at work progresses on each PBB

Contractor Access Route

760'

920'

Contractor Staging Area

Albany International Airport
Capital Region Gateway

Project Description

- Replacement of four passenger boarding bridges at gates A3, A5, B10, and C1.
- Removal and Salvage of two over-the-wing passenger boarding bridges at gates C2 and C3

Key Contacts

- Albany International Airport Authority Contact – John LaClair (518) 242-2255.
- The Operations Director – Jim O'Brien (518) 242-2301.
- ATCT Tower Chief – Mark McCumber (518) 862-1600.

PASSENGER BOARDING BRIDGE IMPROVEMENT PROJECT – PHASE IV

PHASE "1"

Replace PBB – Gate A3

PHASE "2"

Replace PBB – Gate A5

PHASE "3"

Replace PBB – Gate B10

PHASE "4"

Replace PBB – Gate C1

PHASE "5"

Salvage Over-the-Wing PBB – Gate C2

PHASE "6"

Salvage Over-the-Wing PBB – Gate C3

Phase Description

Phases are labeled to match to terminal Concourses:

- Phase 1 includes replacement of PBB at Gate A3
- Phase 2 includes replacement of PBB at Gate A5
- Phase 3 includes replacement of PBB at Gate B10
- Phase 4 includes replacement of PBB at Gate C1
- Phase 5 includes removal and salvage of OTW PBB at Gate C2
- Phase 6 includes removal and salvage of OTW PBB at Gate C3

Phase Restrictions

- Only one phase may be progressed at a time.
- All work outside of the Terminal will occur during VFR conditions.
- Escorts will be required from the staging area and the work areas.

Albany
International
Airport
Capital Region Gateway

PASSENGER BOARDING BRIDGE IMPROVEMENT PROJECT – PHASE IV

Work Area "A3"
Replace PBB – Gate A3

Work Area "A5"
Replace PBB – Gate A5

Work Area "B10"
Replace PBB – Gate B10

Work Area "B10"
Replace PBB – Gate C1

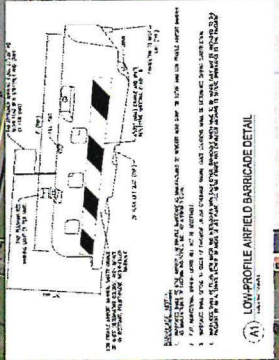

Salvage OTW PBB – Gate C2

Work Area "C3"

Salvage OTW PBB – Gate C3

Work Area "C3"



Work Areas

- Work Areas are named to match to respective gate number (ie. Work Area A3 includes all work required to complete the passenger boarding bridge at gate A3)
- Work Areas include A3, A5, B10, C1, C2, and C3.

Restrictions

- No more than one Passenger Boarding Bridge will be closed at any given time.
- Individual gates will be closed as work progresses on the bridges.
- Barricades shall be placed around each work area

June 2, 2020

Albany County Airport Authority
Attn: Purchasing Agent
Albany International Airport
Administration Building, Room 204
Albany, New York 12211



**RE: COVER LETTER and COVID-19 Precautions and Support of our Clients
ALB Contract Bid 1039-GC and 1039-E**

Dear Albany County Airport Authority and interested parties,

We are pleased to submit these bid package(s) for your consideration. **AERO BridgeWorks, Inc. has included a bid for both the 1039-GC and the 1039-E Contract(s).** We have included two separate bid forms as well as two separate Bid Bonds and two separate DBE participation forms. We are proud to submit this fully responsive proposal and would look forward to delivering a safe and successful Passenger Boarding Bridge replacement and Electrical Project. **AERO has very strong national relationship with JBT and – per the Specifications - we have included JBT Passenger Boarding Bridges.**

Related to the current COVID Pandemic;

Around the globe, businesses are actively managing and adapting to the current market conditions a result of the COVID-19 virus and subsequent impacts to air travel. AERO BridgeWorks, Inc. (AERO) is closely monitoring the situation with local officials, subcontractors, vendors and leadership on all our projects and are including this brief letter for your information.

The personal safety and wellbeing for our clients, employees and industry partners are always a top priority. We have implemented policies to minimize COVID-19 risks. We implemented new crew rotation policies, internal travel restrictions, and in addition to normal best practices for personal hygiene, we mandated all personnel regularly sanitize mobile phones, laptops, work surfaces, tool handles, interior of the vehicle fleet and trailers and to self-distance from the public while working on our airport projects. We also have proactively instituted provisions for a work from home situation as it is necessary and required by governments and municipalities. That said, **AERO's corporate and regional offices are open for business to provide our full complement of services and resources to support our clients on active and new aviation projects.**

To date, we are continuing to deliver on our current project schedules and none of our manufacturer's or vendor's fabrication dates have been delayed. As this situation unfolds, we will update our clients should our vendors begin to experience material shortages or fabrication bottlenecks.

We understand the aviation industry has been heavily impacted and flight operations have experienced rapid decline. We also acknowledge that in due time the COVID-19 impacts will pass. Once it passes, airport gate systems will once again become active. Our PBB/GSE work is historically scheduled around non-stop gate operations and during off-hours. As challenging as the current situation may seem, this market does present an opportunity to complete airside projects such as this one at SDF or other initiatives including annual preventative maintenance, assessments or overdue repairs to your PBB/GSE equipment. As gate operations are currently limited, it is an opportune time to complete this work, and to be prepared when operations increase again. AERO has personnel stationed throughout the nation, so even with airline restrictions, AERO can drive to your site to complete such repairs and maintenance.

Safety is always a top AERO priority – it's part of our culture and a shared value with our clients, vendors and partners. We are here to help ensure your operations remains safe and successful. This is a fluid and changing situation affecting everyone locally and across the globe. The markets will go up and down, governments and municipalities will issue new rules and regulations, but one thing will remain constant. AERO is here to support our clients as a trusted partner to bring us all through these trying times stronger and best prepared for when things return to normal.

Per the RFP we are submitting our proposal electronically by email and we can mail the originals if needed upon request. Please feel free to reach out to me at (919) 796-216 or (770) 423-4200 anytime if AERO can be of assistance or should you have any questions.

Stay safe,

Jay Grantham, PE, LEED, CCM
President
AERO BridgeWorks, Inc.

AERO BridgeWorks, Inc.
2700 Delk Road SE, Suite 150
Marietta, GA 30067
P 770-423-4200
F 770-423-4203
theaerogroup.net



JUNE 2, 2020

ALBANY COUNTY AIRPORT AUTHORITY

ALBANY INTERNATIONAL AIRPORT

Replacement of Passenger Boarding Bridges A3, A5, B10 & C1 - Phase 4

CONTRACT NO. 1039-E

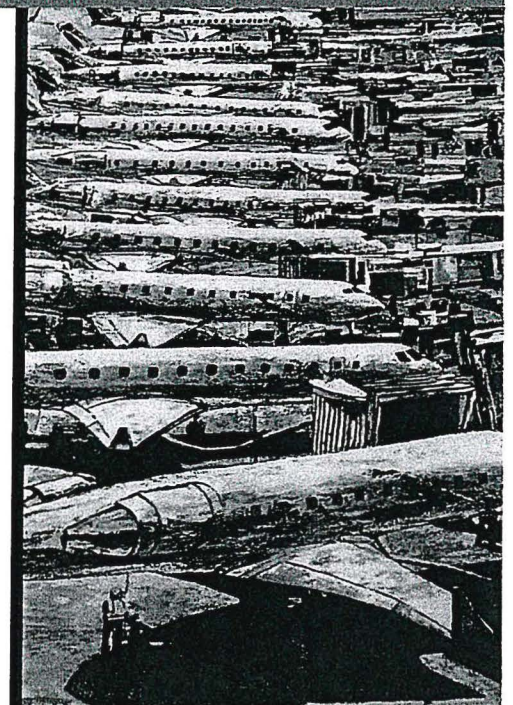
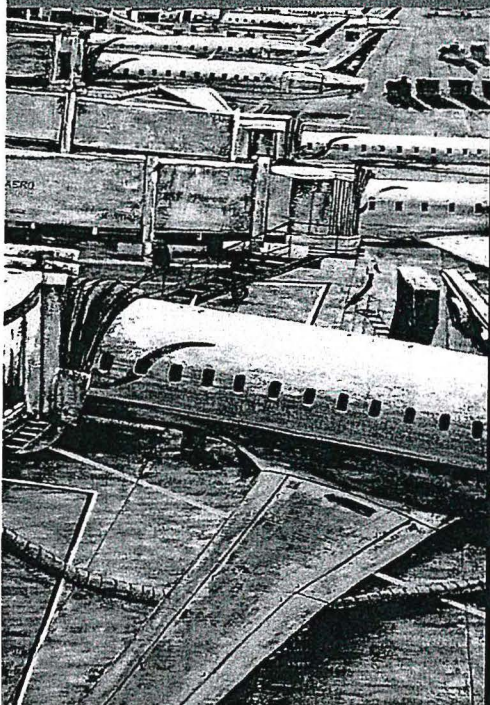
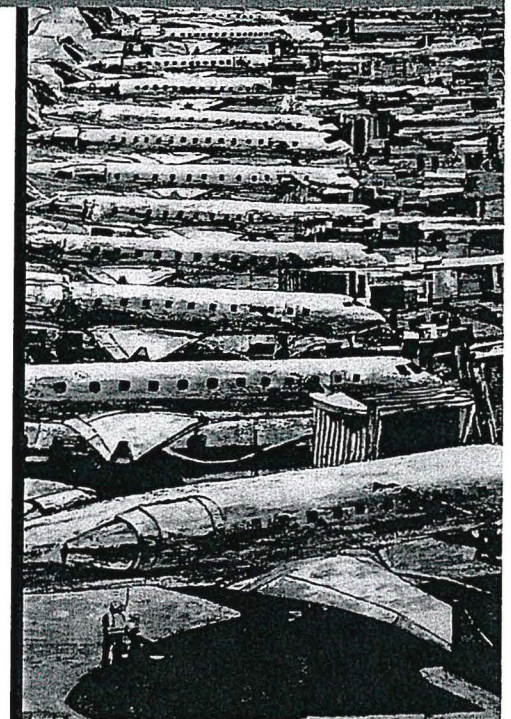
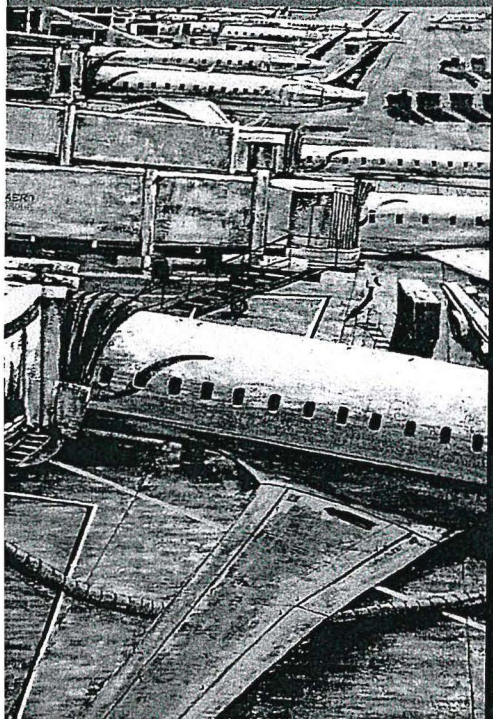

TABLE OF CONTENTS

CONTRACTOR'S BID DOCUMENTS

- BID FORM
- FORM OF BID BOND
- CERTIFIED COPY OF RESOLUTION OF BOARD OF DIRECTORS
- NON-COLLUSION FORM
- BIDDER'S QUALIFICATION QUESTIONNAIRE
- ACKNOWLEDGEMENT BY BIDDER
- EVIDENCE OF BIDDER'S QUALIFICATION TO DO BUSINESS IN NEW YORK STATE
- DBE FORM A
- CONTRACTOR'S CERTIFICATION OF NONSEGREGATED FACILITIES
- CONTRACTOR'S CERTIFICATION OF ELIGIBILITY
- BUY AMERICAN FORM



Contractor's Bid Documents

BID FORM

a) PROJECT IDENTIFICATION:

**Replacement of Passenger Boarding
Bridges A3, A5, B10 & C1 – Phase 4
Albany County Airport Authority
Albany International Airport
Albany, New York
Contract No. 1039-GC**

b) THIS BID IS SUBMITTED TO:

Albany County Airport Authority
Purchasing Agent
Albany International Airport
Administration Building, Room 204
Albany, New York 12211

c) TIME OF COMPLETION:

Substantial completion is 210 calendar days after Notice to Proceed. Final completion is 240 calendar days after Notice to Proceed.

The undersigned BIDDER proposes and agrees, if this Bid is accepted, to enter into an Agreement with AUTHORITY in the form included in the Contract Documents to complete all Work as specified or indicated in the Contract Documents for the Contract Price and within the Contract Time indicated in the Agreement and in accordance with the Contract Documents.



BIDDER accepts all of the terms and conditions of the Instructions to Bidders, including without limitation those dealing with the disposition of Bid Security. This Bid will remain open for forty-five (45) days after the day of Bid opening. BIDDER will sign the Agreement and submit the Bonds and other documents required by the Contract Documents within (7) calendar days after the date of AUTHORITY'S Notice of Award.

In submitting this Bid, BIDDER represents, as more fully set in the Agreement, that:

- (a)** BIDDER has examined the site and locality where the Work is to be performed, the legal requirements (federal, state and local laws, ordinances, rules and regulations) and the conditions affecting cost, progress or performance of the Work and has made such independent investigations as BIDDER deems necessary;
- (b)** This Bid is genuine and not made in the interest of or on behalf of any undisclosed person, firm or corporation and is not submitted in conformity with any agreement or rules of any group, association, organization or corporation; BIDDER has not directly or indirectly induced or solicited any other Bidder to submit a false or sham Bid; BIDDER has not solicited or induced any person, firm or a corporation to refrain from bidding; and BIDDER has not sought by collusion to obtain for himself any advantage over any other Bidder or over AUTHORITY;

Contract No. 1039-GC BID

- (c) BIDDER has examined copies of all of the Contract Documents;
- (d) BIDDER further understands and agrees that he is to furnish and provide for the lump sum amount of the Base Bid, plus the amount Bid for any Alternates as selected by the AUTHORITY, if any, totaled separately, all the necessary material, machinery, implements, tools, labor, services, and other items of whatever nature, and to do and perform all the construction necessary under the aforesaid conditions, to complete the Work in accordance with the Contract Documents, which it is agreed, are a part of this Bid, and to accept in full compensation therefore the amount of the total lump sum Bid.
- (e) BIDDER further agrees that, at any time during the progress of Work, if the AUTHORITY adds, alters or omits portions of the Work, BIDDER shall so perform such Work and accept as compensation a lump sum price mutually agreed to prior to the start of the Additional Work.
- (f) BIDDER acknowledges the receipt of the following addenda: (If none, so state and affix signature).

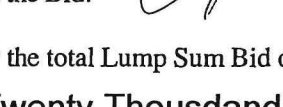
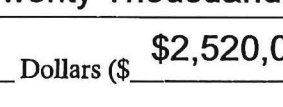
<u>Addendum</u>	<u>Date</u>	<u>Signature</u>
<u>1</u>	<u>5/15/2020</u>	
<u>2</u>	<u>5/18/2020</u>	
<u>3</u>	<u>5/22/2020</u>	
<u>4</u>	<u>5/26/2020</u>	
<u>5</u>	<u>5/29/2020</u>	

and have included these requirements in the Bid.

- (g) BIDDER will complete all the Work for the total Lump Sum Bid of:

Two Million Five Hundred Twenty Thousand
 _____ Dollars (\$ **\$2,520,000.00**)

BIDDER agrees that the Work will be substantially completed within the number of calendar days indicated in Article 4.1 of the Agreement.

BIDDER accepts the provisions of Article 4.2 of the Agreement as to liquidated damages in the event of failure to complete the Work within the Contract Time.

The terms used in this Bid are defined in the Agreement or elsewhere in the Contract Documents and have the meanings assigned to them in the Agreement or other Contract Documents.

The following documents are attached to and made a part of this Bid:

- (a) Bid Bond

- (b) Certified Copy of Resolution of Board of Directors
- (c) Non-Collusion Form
- (d) Bidder Qualification Questionnaire
- (e) Acknowledgment by Bidder

DATE: June 2, 2020

AERO BridgeWorks, Inc.
Legal Name of Person, Partnership
or Corporation

By:

Authorized Signature

Jay Grantham - President
Title

2700 Delk Road SE, Suite 150 Marietta, GA 30067
Address

Jay Grantham
NAME OF CONTACT PERSON

770.423.4200
TELEPHONE NUMBER

770.423.4203
FACSIMILE NUMBER



BID FORM

a) PROJECT IDENTIFICATION:

**Replacement of Passenger Boarding
Bridges A3, A5, B10 & C1 – Phase 4**
Albany County Airport Authority
Albany International Airport
Albany, New York
Contract No. 1039-E

b) THIS BID IS SUBMITTED TO:

Albany County Airport Authority
Purchasing Agent
Albany International Airport
Administration Building, Room 204
Albany, New York 12211

c) TIME OF COMPLETION:

Substantial completion is 210 calendar days after Notice to Proceed. Final completion is 240 calendar days after Notice to Proceed.

The undersigned BIDDER proposes and agrees, if this Bid is accepted, to enter into an Agreement with AUTHORITY in the form included in the Contract Documents to complete all Work as specified or indicated in the Contract Documents for the Contract Price and within the Contract Time indicated in the Agreement and in accordance with the Contract Documents.



BIDDER accepts all of the terms and conditions of the Instructions to Bidders, including without limitation those dealing with the disposition of Bid Security. This Bid will remain open for forty-five (45) days after the day of Bid opening. BIDDER will sign the Agreement and submit the Bonds and other documents required by the Contract Documents within (7) calendar days after the date of AUTHORITY'S Notice of Award.

In submitting this Bid, BIDDER represents, as more fully set in the Agreement, that:

- (a) BIDDER has examined the site and locality where the Work is to be performed, the legal requirements (federal, state and local laws, ordinances, rules and regulations) and the conditions affecting cost, progress or performance of the Work and has made such independent investigations as BIDDER deems necessary;
- (b) This Bid is genuine and not made in the interest of or on behalf of any undisclosed person, firm or corporation and is not submitted in conformity with any agreement or rules of any group, association, organization or corporation; BIDDER has not directly or indirectly induced or solicited any other Bidder to submit a false or sham Bid; BIDDER has not solicited or induced any person, firm or a corporation to refrain from bidding; and BIDDER has not sought by collusion to obtain for himself any advantage over any other Bidder or over AUTHORITY;

Contract No. 1039-E BID

- (c) BIDDER has examined copies of all of the Contract Documents;
- (d) BIDDER further understands and agrees that he is to furnish and provide for the lump sum amount of the Base Bid, plus the amount Bid for any Alternates as selected by the AUTHORITY, if any, totaled separately, all the necessary material, machinery, implements, tools, labor, services, and other items of whatever nature, and to do and perform all the construction necessary under the aforesaid conditions, to complete the Work in accordance with the Contract Documents, which it is agreed, are a part of this Bid, and to accept in full compensation therefore the amount of the total lump sum Bid.
- (e) BIDDER further agrees that, at any time during the progress of Work, if the AUTHORITY adds, alters or omits portions of the Work, BIDDER shall so perform such Work and accept as compensation a lump sum price mutually agreed to prior to the start of the Additional Work.
- (f) BIDDER acknowledges the receipt of the following addenda: (If none, so state and affix signature).

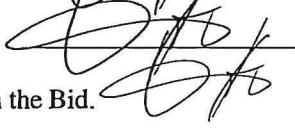
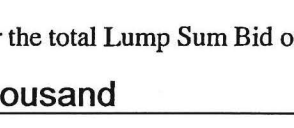
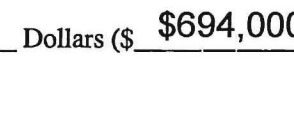
<u>Addendum</u>	<u>Date</u>	<u>Signature</u>
<u>1</u>	<u>5/15/2020</u>	
<u>2</u>	<u>5/18/2020</u>	
<u>3</u>	<u>5/22/2020</u>	
<u>4</u>	<u>5/26/2020</u>	
<u>5</u>	<u>5/29/2020</u>	

and have included these requirements in the Bid.

- (g) BIDDER will complete all the Work for the total Lump Sum Bid of:
Six Hundred Ninety Four Thousand
_____ Dollars (\$ 694,000.00).

BIDDER agrees that the Work will be substantially completed within the number of calendar days indicated in Article 4.1 of the Agreement.

BIDDER accepts the provisions of Article 4.2 of the Agreement as to liquidated damages in the event of failure to complete the Work within the Contract Time.

The terms used in this Bid are defined in the Agreement or elsewhere in the Contract Documents and have the meanings assigned to them in the Agreement or other Contract Documents.

The following documents are attached to and made a part of this Bid:

- (a) Bid Bond
- (b) Certified Copy of Resolution of Board of Directors
- (c) Non-Collusion Form
- (d) Bidder Qualification Questionnaire
- (e) Acknowledgment by Bidder

DATE: June 2, 2020

AERO BridgeWorks, Inc.

Legal Name of Person, Partnership
or Corporation

By:

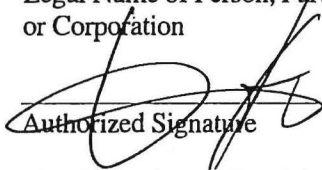
Authorized Signature

Jay Grantham - President

Title

2700 Delk Road SE, Suite 150 Marietta, GA 30067
Address

Jay Grantham

NAME OF CONTACT PERSON

770.423.4200

TELEPHONE NUMBER

770.423.4203

FACSIMILE NUMBER



FORM OF BID BOND

(To be submitted, at the option of the Bidder, in lieu of certified check for guarantee.)

Bond No. LMIABW-45

Contract 1039-GC

KNOW ALL MEN BY THESE PRESENTS, That we, the undersigned, AERO BridgeWorks, Inc.,
as Principal, and Liberty Mutual Insurance Company,
as Surety, are hereby held and firmly bound unto the Albany County Airport Authority, Administration Building, Second Floor, Albany International Airport, Albany, New York 12211 (the "AUTHORITY"), as Obligee, in the penal sum of Five Percent of Amount Bid Dollars, (\$ 5% of Amount Bid) lawful money of the United States of America, for the payment of which well and truly to be made, we hereby jointly and severally bind ourselves, our heirs, executors, administrators, successors and assigns.

WHEREAS, the Principal has submitted to the Obligee a certain Bid, dated 5/28/2020, attached hereto and made a part hereof, to enter into an Agreement in writing, for the rehabilitation and/or construction of the Work specified in such Bid and Agreement.

NOW, THEREFORE, THE CONDITION OF THIS OBLIGATION IS SUCH, that:

- (a) If said Bid shall be rejected, or in the alternate,
- (b) If said Bid shall be accepted and the Principal shall execute and deliver an Agreement in the form of Agreement attached hereto (properly completed in accordance with said Bid) and shall furnish a bond for his faithful performance of said Agreement, and for the payment of all persons performing labor or furnishing materials in connection therewith, and shall in all other respects perform the Agreement created by the acceptance of said Bid, then this obligation shall be void, otherwise the same shall remain in force and effect; it being expressly understood and agreed that the liability of the Surety for any and all claims hereunder shall in no event exceed, in the aggregate, the penal amount of this obligation as herein stated.

The Surety, for value received, hereby stipulates and agrees that the obligations of said Surety and its bond shall be in no way impaired or affected by an extension of the time within which the AUTHORITY may accept such Bid; and said Surety does hereby waive notice of any such extension.

IN WITNESS WHEREOF, the Principal and Surety have hereunto set their hands and seals and such of them as are corporations have caused their corporate seals to be hereto affixed and these presents to be signed by their proper officers, this 28th day of May, 2020

AERO BridgeWorks, Inc.

(Principal)

By:

Jay Grantham, President

Liberty Mutual Insurance Company

(Surety)

By:

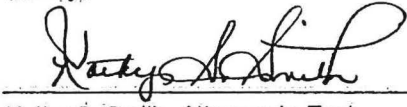
Kathy S. Smith, Attorney-in-Fact

This Power of Attorney limits the acts of those named herein, and they have no authority to bind the Company except in the manner and to the extent herein stated. Not valid for mortgage, note, loan, letter of credit, bank deposit, currency rate, interest rate or residual value guarantees. To confirm the validity of this Power of Attorney call 610-832-8240 between 9:00 am and 4:30 pm EST on any business day.



Liberty Mutual.

SURETY

Liberty Mutual Insurance Company
The Ohio Casualty Insurance Company
West American Insurance Company

POWER OF ATTORNEY

KNOWN ALL PERSONS BY THESE PRESENTS: That The Ohio Casualty Insurance Company is a corporation duly organized under the laws of the State of New Hampshire, that Liberty Mutual Insurance Company is a corporation duly organized under the laws of the State of Massachusetts, and West American Insurance Company is a corporation duly organized under the laws of the State of Indiana (herein collectively called the "Companies"), pursuant to and by authority herein set forth, does hereby name, constitute and appoint Kathy S. Smith of the city of Lilburn, state of GA its true and lawful attorney-in-fact, with full power and authority hereby conferred to sign, execute and acknowledge the following surety bond:

Principal Name: AERO BridgeWorks, Inc.

Obligee Name: Albany County Airport Authority

Surety Bond Number: Bid Bond Bond Amount: See Bond Form

IN WITNESS WHEREOF, this Power of Attorney has been subscribed by an authorized officer or official of the Companies and the corporate seals of the Companies have been affixed hereto this 12th day of December, 2018.



The Ohio Casualty Insurance Company
Liberty Mutual Insurance Company
West American Insurance Company

By: David M. Carey
David M. Carey, Assistant Secretary

STATE OF PENNSYLVANIA ss
COUNTY OF MONTGOMERY

On this 12th day of December, 2018, before me personally appeared David M. Carey, who acknowledged himself to be the Assistant Secretary of Liberty Mutual Insurance Company, The Ohio Casualty Company, and West American Insurance Company, and that he, as such, being authorized so to do, execute the foregoing instrument for the purposes therein contained by signing on behalf of the corporations by himself as a duly authorized officer.

IN WITNESS WHEREOF, I have hereunto subscribed my name and affixed my notarial seal at King of Prussia, Pennsylvania, on the day and year first above written.



COMMONWEALTH OF PENNSYLVANIA
Notarial Seal
Teresa Pastella, Notary Public
Upper Merion Twp., Montgomery County
My Commission Expires March 28, 2021
Member, Pennsylvania Association of Notaries

By: Teresa Pastella
Teresa Pastella, Notary Public

This Power of Attorney is made and executed pursuant to and by authority of the following By-laws and Authorizations of Liberty Mutual Insurance Company, The Ohio Casualty Insurance Company, and West American Insurance Company which resolutions are now in full force and effect reading as follows:

ARTICLE IV - OFFICERS - Section 12. Power of Attorney. Any officer or other official of the Corporation authorized for that purpose in writing by the Chairman or the President, and subject to such limitation as the Chairman or the President may prescribe, shall appoint such attorneys-in-fact, as may be necessary to act in behalf of the Corporation to make, execute, seal, acknowledge and deliver as surety any and all undertakings, bonds, recognizances and other surety obligations. Such attorneys-in-fact, subject to the limitations set forth in their respective powers of attorney, shall have full power to bind the Corporation by their signature and execution of any such instruments and to attach thereto the seal of the Corporation. When so executed, such instruments shall be as binding as if signed by the President and attested to by the Secretary. Any power or authority granted to any representative or attorney-in-fact under the provisions of this article may be revoked at any time by the Board, the Chairman, the President or by the officer or officers granting such power or authority.

ARTICLE XIII - Execution of Contracts - SECTION 5. Surety Bonds and Undertakings. Any officer of the Company authorized for that purpose in writing by the chairman or the president, and subject to such limitations as the chairman or the president may prescribe, shall appoint such attorneys-in-fact, as may be necessary to act in behalf of the Company to make, execute, seal, acknowledge and deliver as surety any and all undertakings, bonds, recognizances and other surety obligations. Such attorneys-in-fact subject to the limitations set forth in their respective powers of attorney, shall have full power to bind the Company by their signature and execution of any such instruments and to attach thereto the seal of the Company. When so executed such instruments shall be as binding as if signed by the president and attested by the secretary.

Certificate of Designation - The President of the Company, acting pursuant to the Bylaws of the Company, authorizes David M. Carey, Assistant Secretary to appoint such attorneys-in-fact as may be necessary to act on behalf of the Company to make, execute, seal, acknowledge and deliver as surety any and all undertakings, bonds, recognizances and other surety obligations.

Authorization - By unanimous consent of the Company's Board of Directors, the Company consents that facsimile or mechanically reproduced signature of any assistant secretary of the Company, wherever appearing upon a certified copy of any power of attorney issued by the Company in connection with surety bonds, shall be valid and binding upon the Company with the same force and effect as though manually affixed.

I, Ronae C. Llewellyn, the undersigned, Assistant Secretary, of Liberty Mutual Insurance Company, The Ohio Casualty Insurance Company, and West American Insurance Company do hereby certify that this power of attorney executed by said Companies is in full force and effect and has not been revoked.

IN TESTIMONY WHEREOF, I have hereunto set my hand and affixed the seals of said Companies this 28th day of May, 2020.



By: Ronae C. Llewellyn
Ronae C. Llewellyn, Assistant Secretary

AERO BridgeWorks, Inc.

(Principal)

By:

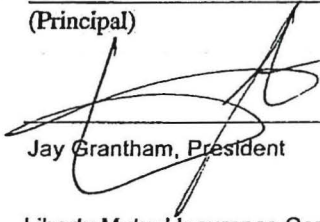

Jay Grantham, President

Liberty Mutual Insurance Company

(Surety)

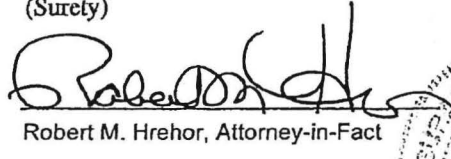
By:

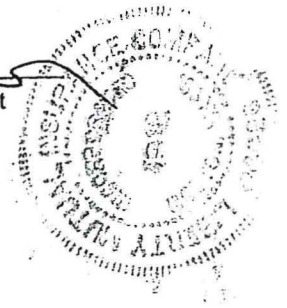
Robert M. Hrehor, Attorney-in-Fact



This Power of Attorney limits the acts of those named herein, and they have no authority to bind the Company except in the manner and to the extent herein stated. Not valid for mortgage, note, loan, letter of credit, bank deposit, currency rate, interest rate or residual value guarantees. To confirm the validity of this Power of Attorney call 610-832-8240 between 9:00 am and 4:30 pm EST on any business day.



Liberty Mutual.

SURETY

Liberty Mutual Insurance Company
The Ohio Casualty Insurance Company
West American Insurance Company

POWER OF ATTORNEY

KNOWN ALL PERSONS BY THESE PRESENTS: That The Ohio Casualty Insurance Company is a corporation duly organized under the laws of the State of New Hampshire, that Liberty Mutual Insurance Company is a corporation duly organized under the laws of the State of Massachusetts, and West American Insurance Company is a corporation duly organized under the laws of the State of Indiana (herein collectively called the "Companies"), pursuant to and by authority herein set forth, does hereby name, constitute and appoint Robert M. Hrehor of the city of Liburn, state of GA its true and lawful attorney-in-fact, with full power and authority hereby conferred to sign, execute and acknowledge the following surety bond:

Principal Name: AERO BridgeWorks, Inc.

Obligee Name: Albany County Airport Authority

Surety Bond Number: Bid Bond Bond Amount: See Bond Form

IN WITNESS WHEREOF, this Power of Attorney has been subscribed by an authorized officer or official of the Companies and the corporate seals of the Companies have been affixed hereto this 12th day of December, 2018.



The Ohio Casualty Insurance Company
Liberty Mutual Insurance Company
West American Insurance Company

By: David M. Carey
David M. Carey, Assistant Secretary

STATE OF PENNSYLVANIA ss
COUNTY OF MONTGOMERY

On this 12th day of December, 2018, before me personally appeared David M. Carey, who acknowledged himself to be the Assistant Secretary of Liberty Mutual Insurance Company, The Ohio Casualty Company, and West American Insurance Company, and that he, as such, being authorized so to do, execute the foregoing instrument for the purposes therein contained by signing on behalf of the corporations by himself as a duly authorized officer.

IN WITNESS WHEREOF, I have hereunto subscribed my name and affixed my notarial seal at King of Prussia, Pennsylvania, on the day and year first above written.



COMMONWEALTH OF PENNSYLVANIA
Notarial Seal
Teresa Pastella, Notary Public
Upper Merion Twp., Montgomery County
My Commission Expires March 28, 2021
Member, Pennsylvania Association of Notaries

By: Teresa Pastella
Teresa Pastella, Notary Public

This Power of Attorney is made and executed pursuant to and by authority of the following By-laws and Authorizations of Liberty Mutual Insurance Company, The Ohio Casualty Insurance Company, and West American Insurance Company which resolutions are now in full force and effect reading as follows:

ARTICLE IV – OFFICERS – Section 12. Power of Attorney. Any officer or other official of the Corporation authorized for that purpose in writing by the Chairman or the President, and subject to such limitation as the Chairman or the President may prescribe, shall appoint such attorneys-in-fact, as may be necessary to act in behalf of the Corporation to make, execute, seal, acknowledge and deliver as surety any and all undertakings, bonds, recognizances and other surety obligations. Such attorneys-in-fact, subject to the limitations set forth in their respective powers of attorney, shall have full power to bind the Corporation by their signature and execution of any such instruments and to attach thereto the seal of the Corporation. When so executed, such instruments shall be as binding as if signed by the President and attested to by the Secretary. Any power or authority granted to any representative or attorney-in-fact under the provisions of this article may be revoked at any time by the Board, the Chairman, the President or by the officer or officers granting such power or authority.

ARTICLE XIII – Execution of Contracts – SECTION 5. Surety Bonds and Undertakings. Any officer of the Company authorized for that purpose in writing by the chairman or the president, and subject to such limitations as the chairman or the president may prescribe, shall appoint such attorneys-in-fact, as may be necessary to act in behalf of the Company to make, execute, seal, acknowledge and deliver as surety any and all undertakings, bonds, recognizances and other surety obligations. Such attorneys-in-fact subject to the limitations set forth in their respective powers of attorney, shall have full power to bind the Company by their signature and execution of any such instruments and to attach thereto the seal of the Company. When so executed such instruments shall be as binding as if signed by the president and attested by the secretary.

Certificate of Designation – The President of the Company, acting pursuant to the Bylaws of the Company, authorizes David M. Carey, Assistant Secretary to appoint such attorneys-in-fact as may be necessary to act on behalf of the Company to make, execute, seal, acknowledge and deliver as surety any and all undertakings, bonds, recognizances and other surety obligations.

Authorization – By unanimous consent of the Company's Board of Directors, the Company consents that facsimile or mechanically reproduced signature of any assistant secretary of the Company, wherever appearing upon a certified copy of any power of attorney issued by the Company in connection with surety bonds, shall be valid and binding upon the Company with the same force and effect as though manually affixed.

I, Renee C. Llewellyn, the undersigned, Assistant Secretary of Liberty Mutual Insurance Company, The Ohio Casualty Insurance Company, and West American Insurance Company do hereby certify that this power of attorney executed by said Companies is in full force and effect and has not been revoked.

IN TESTIMONY WHEREOF, I have hereunto set my hand and affixed the seals of said Companies this 28th day of May 2020.



By: Renee C. Llewellyn
Renee C. Llewellyn, Assistant Secretary

**CERTIFIED COPY OF RESOLUTION OF
BOARD OF DIRECTORS OF**

(NAME OF CORPORATION)

RESOLVED that Jay Grantham, President
(Person Authorized to Sign) (Title)
of AERO BridgeWorks, Inc. be authorized to sign and
(NAME OF CORPORATION)

submit the Bid of this corporation for the following Project: Replacement of Passenger Boarding Bridges A3, A5, B10 & C1 – Phase 4 and to include in such bid the certificate as to non-collusion, and for any inaccuracies or misstatements in such certificate this corporate Bidder shall be liable under the penalties of perjury.

The foregoing is a true and correct copy of the resolution adopted by _____
AERO BridgeWorks, Inc. at a meeting of its Board of Directors
held _____
(NAME OF CORPORATION)

on the 28th day of May 2020

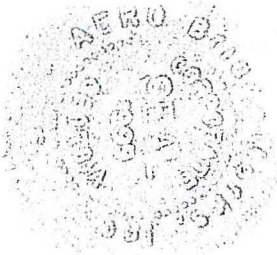

(SEAL)

By: Jay Grantham 

Title: President

The above form must be completed if the Bidder is a Corporation.

ALBANY COUNTY AIRPORT AUTHORITY

STATEMENT OF NON-COLLUSION

Pursuant to Section 2878 of the New York Public Authorities Law.

Non-collusive bidding certification.

(a) By submission of this Bid, each Bidder and each person signing on behalf of any Bidder certifies, and in the case of a joint bid each party thereto certifies as to its own organization, under penalty of perjury, that to the best of his knowledge and belief:

- (1) The prices in this Bid have been arrived at independently without collusion, consultation, communication, or agreement, for the purpose of restricting competition, as to any matter relating to such prices with any other Bidder or with any competitor;
- (2) Unless otherwise required by law, the prices which have been quoted in this Bid have not been knowingly disclosed by the Bidder and will not knowingly be disclosed by the Bidder prior to opening, directly or indirectly, to any other Bidder or to any competitor; and,
- (3) No attempt has been made or will be made by the Bidder to induce any other person, partnership or corporation to submit or not to submit a bid for the purpose of restricting competition.

This statement is subscribed by the undersigned and affirmed by such bidder as true under the penalties of perjury.

FIRM (Bidder)



SIGNED Jay Grantham - President

DATE 6/2/2020

(b) A bid shall not be considered for award nor shall any award be made where (a)(1) (2) and (3) above have not been complied with; provided however, that if in any case the bidder cannot make the foregoing certification, the bidder shall so state and shall furnish with the bid a signed statement which sets forth in detail the reasons therefor. Where (a) (1) (2) and (3) above have not been complied with, the bid shall not be considered for award nor shall any award be made unless the head of the purchasing unit of the state, public department or agency to which the bid is made, or his designee, determines that such disclosure was not made for the purpose of restricting competition.

The fact that a bidder (a) has published price lists, rates, or tariffs covering items being procured, (b) has informed prospective customers of proposed or pending publication of new or revised price lists for such items, or (c) has sold the same items to other customers at the same prices being bid, does not constitute, without more, a disclosure within the meaning of subparagraph one (a).

*Based on AERO's performance, cost effectiveness and quality on these projects, the Owner selected to add additional gates and additional scope to our Contract after Contract Award. These changes were not introduced by AERO. Specific for ATL, ATL added Phase 2 to the Contract, which was an additional 30 Gates. The MSY original scope was a refurbishment project, but the Owner elected to add 24 new gates to the Project. In BOS, American elected to add subsequent phases, which included new fixed walkways, after Contract award.

**BIDDER'S QUALIFICATION
QUESTIONNAIRE**

CONTRACT NO. 1039-GC & E

**REPLACEMENT OF PASSENGER BOARDING
BRIDGES A3, A5, B10 & C1 – PHASE 4**

The undersigned guarantees the accuracy of all statements and answers herein contained. *(Please print in ink).*

1. How many years has your firm been in business as a Contractor?

21

2. List up to three (3) projects of this nature that you have completed in the last three (3) years, and give the name, address and telephone number of a reference from each. Also give the completion date, the original contract bid price and the completed cost of each project listed. *Please see note above

PBB Replacement/Refurbishment - Hartsfield-Jackson Atlanta International Airport - 1/2020

Shawn Craig - 678.749.9443 - 3368 Hardee Ave. Atlanta, GA 30341 -
Original: \$33,136,664 Change orders: \$28,494,501 Final: \$61,631,165

North Terminal Project - Louis Armstrong New Orleans International Airport - 11/2019

Jerry Sheets - 504.715.2544 - 13355 Noel Rd, Floor 4 Dallas, TX 75240 -
Original \$7,180,673 Change orders: \$17,231,984 Final: \$24,412,657

Terminal B Optimization - Boston Logan International Airport - 12/2019

Mike Napoli - 817.967.1097 - 13355 Noel Rd, Floor 4 Dallas, TX 75240 -
Original: \$1,091,725 Change orders: \$1,198,699 Final: \$2,290,424

3. List projects presently under construction by your firm the dollar volume of the contract and the percentage completion of the contract.

Richmond International Airport (RIC)	PBB/Airside	\$6.1M	10%
San Francisco International Airport (SFO)	PBB/Airside	\$2.5M	60%
Salt Lake City International Airport (SLC)	PBB/Airside	\$4.9M	60%
Norfolk International Airport (ORF)	PBB/Airside	\$17.7M	70%
Raleigh-Durham International Airport (RDU)	A1/A2 Walkway & PBB	\$5.2M	80%
Hartsfield Jackson Atlanta Int'l Airport (ATL)	PBB/Airside	\$50.3M	80%
Seattle-Tacoma International Airport (SEA)	PBB/Airside	\$1.6M	40%
Fort Lauderdale International Airport (FLL)	PBB/Airside	\$3.8M	30%
Memphis International Airport (MEM)	PBB Replacement	\$33M	30%
Seattle-Tacoma International Airport (SEA)	A-VDGS/Airside	\$8M	5%
LaGuardia Airport (LGA)	A-VDGS/Airside	\$500K	60%
Bozeman Airport (BZM)	PBB/Airside	\$3.5M	10%
Portsmouth Airport (PSM)	PBB/Airside	\$800K	10%
Memphis International Airport (MEM)	PBB/Airside	\$1.3M	25%
Rogue Valley-Medford Airport (MFR)	PBB/Airside	\$1.5M	40%
Orlando Melbourne International Airport (MLB)	PBB/Airside	\$2.3M	75%

4. Have you ever failed to complete work on a contract awarded to you? If so, state where and why.

No

5. Do you plan to subcontract any part of this work? If so, give details.

We self perform the PBB installations. We will subcontract the PBB equipment and site civil work.

6. What equipment do you own that is available for this work?

We own work trucks, personnel vehicles, trailers, job boxes and technology.

7. What equipment do you plan to rent or purchase for this work?

We plan to rent fork lifts, scissor lifts, boom lifts from a local equipment supplier. We will also engage a local crane and trucking firm.

8. Have you ever performed work under the direction of a Professional Engineer or Registered Architect? If so, list up to three (3) such firms giving the name of the firm, its address, telephone number and the name of the project. (List most recent projects).

AERO Systems Engineering - Chris Briton - 2700 Delk Road SE, Suite 100 Marietta, GA 30067
770.423.4200 - PBB Replacement/Upgrade - Hartsfield-Jackson Atlanta Int'l Airport (ATL)

Gresham Smith – Matt Amos - 919 E Main Street, Suite 1200 Richmond, VA 23219
804.788.0710 - Jetbridge Replacement Project - Norfolk International Airport (ORF)

Gensler – Michael Wagner - 613 Hillsborough St Raleigh, NC 27603
919.239.7828 - Terminal 1 Gates A1-A4 - Raleigh-Durham International Airport (RDU)

9. Give the name, address and telephone number of an individual who represents each of the following and whom the Authority may contact to investigate your financial responsibility: a surety, a bank, and a major material supplier.

JBT - Garrett MacFarlane - 1805 West 2550 South, Ogden, UT 84401 - 801.940.1801

United Community Bank - C.B. Fair, III - 200 Cherokee Street Marietta, GA 30060 - 770.794.3422

BDH Associates - Kathy Smith - 4572 Lawrenceville Hwy., Suite 201 Lilburn, GA 30047 - 678.218.1424

10. Give a summary of your financial statement. List assets and liabilities, use an insert sheet, if needed. Only the three (3) lowest bidders shall submit this information to the Authority within one hundred twenty (120) hours of the opening of the Bids.

We will provide this information within 120 hours of the bid opening if we are one of three

lowest bidders.

11. Is your firm presently or has your firm ever been a party defendant in a lawsuit commenced against your firm alleging failure to properly complete work in accordance with the contract for same; if so, give details.

No

Governmental Entity: N/A

Date of Termination or Withholding of Contract: N/A

Basis of Termination or Withholding: N/A

(Add additional pages as necessary)

14. State the true, exact, correct and complete name of the partnership, corporation and trade name under which you do business, and the address of the place of business. (If a partnership, state the name of all general partners. If a trade name, state the names of the individuals who do business under the trade name.) It is absolutely necessary that this information be furnished.

Complete Legal Name of Bidder AERO BridgeWorks, Inc.

(a) The Bidder is a S-Corporation
(corporation, partnership, or individual)

(b) The State of incorporation or partnership is Georgia

(c) The address of principal place of business is (in case of an individual, also list residence):
2700 Delk Road SE, Suite 150
Marietta, GA 30067

(d) The names of the corporate officers, or partners, or individuals doing business under a trade name, are as follows:

Jay Grantham - President

Tim Carruba - Vice President

Alvin Allison - Secretary/Treasurer

Signature of BIDDER

Jay Grantham - President
Print Name and Title

Jay Grantham - 770.423.4200 - 770.423.4203

Name of Contact Person - Telephone No. - Facsimile No.

By acknowledging, below, Bidder certifies that all information provided (including information with respect to State Finance Law §139k) is complete, true and accurate. The Authority reserves the right to terminate the contract in the event it is found that the certification filed by the Bidder in accordance with New York State Finance Law §139k was intentionally false or intentionally incomplete. Upon such finding, the Authority may exercise its termination right by providing written notification to the Bidder in accordance with the written notification terms of this contract.

ACKNOWLEDGMENT BY BIDDER:

If Individual or Individuals:

State of _____)
) ss.:
County of _____)

On this ___ day of _____, 20__ before me personally appeared _____, known to me to be same person(s) described in and who executed the within instrument, and ___ he (or they severally) acknowledged to me that ___ he (or they) executed the same.

Notary Public

State of _____
Qualified in _____
My Commission expires _____

If Corporation:

State of GA)
County of COBB) ss.:

On this 28th day of MAY, 20__ before me personally appeared _____
Jay Grantham, to me known, who, being by me sworn, did say that ___ he resides
at (give address) 2700 Delk Road SE, Suite 150 Marietta, GA 30067
; that ___ he is the (give title) President of (name of Corporation), _____
AERO BridgeWorks. Inc., the Corporation described in
and which executed the above instrument; that ___ he knows the seal of the Corporation; that the seal was
affixed to the foregoing instrument by order of the Board of Directors of the Corporation; and that ___ he
signed his name thereto by like order.

Renee Oldham
Notary Public

State of GA
Qualified in _____
My Commission expires 11/13/2023



EVIDENCE OF BIDDER'S QUALIFICATION TO DO BUSINESS IN NEW YORK STATE

NYS Department of State

Division of Corporations

Entity Information

The information contained in this database is current through May 20, 2020.

Selected Entity Name: AERO BRIDGEWORKS, INC.

Selected Entity Status Information

Current Entity Name: AERO BRIDGEWORKS, INC.

DOS ID #: 4153725

Initial DOS Filing Date: OCTOBER 14, 2011

County: QUEENS

Jurisdiction: GEORGIA

Entity Type: FOREIGN BUSINESS CORPORATION

Current Entity Status: ACTIVE

Selected Entity Address Information

DOS Process (Address to which DOS will mail process if accepted on behalf of the entity)

AERO BRIDGEWORKS, INC.
2700 DELK ROAD SE
SUITE 150
MARIETTA, GEORGIA, 30067

Chief Executive Officer

MICHAEL W. MADLOCK
2700 DELK ROAD SE
SUITE 150
MARIETTA, GEORGIA, 30067

Principal Executive Office

AERO BRIDGEWORKS, INC.
2700 DELK ROAD SE
SUITE 150
MARIETTA, GEORGIA, 30067

Registered Agent

NONE

This office does not record information regarding the names and addresses of officers, shareholders or directors of nonprofessional corporations except the chief executive officer, if provided, which would be listed above. Professional corporations must include the name(s) and address(es) of the initial officers, directors, and shareholders in the initial certificate of incorporation, however this information is not recorded and only available by viewing the certificate.

*Stock Information

# of Shares	Type of Stock	\$ Value per Share
No Information Available		

*Stock information is applicable to domestic business corporations.

Name History

Filing Date	Name Type	Entity Name
OCT 14, 2011	Actual	AERO BRIDGEWORKS, INC.

A **Fictitious** name must be used when the **Actual** name of a foreign entity is unavailable for use in New York State. The entity must use the fictitious name when conducting its activities or business in New York State.

NOTE: New York State does not issue organizational identification numbers.

[Search Results](#) [New Search](#)

[Services/Programs](#) | [Privacy Policy](#) | [Accessibility Policy](#) | [Disclaimer](#) | [Return to DOS Homepage](#) | [Contact Us](#)

**Albany County Airport Authority
DISADVANTAGED BUSINESS ENTERPRISE FORM - A**

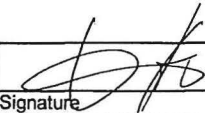
AERO BridgeWorks, Inc. Name of Bidder 2700 Delk Rd. SE, Suite 150 Marietta, GA 30067 Address 770.423.4200 Telephone Number 770.423.4203 Fax Number				1039-GC Contract Number Replacement of Passenger Boarding Bridges - A3, A5, B10 & C1 - Phase 4 Project Name Replacement of passenger board Description bridges at Gates A3, A5, B10, and C1 as well as new pre-conditioned air and Ground Power Units at the impacted bridges.			
Name, Address, Telephone and Federal Tax Number	Minority or Female Owned	Scope of Work/Services	Est Start Date	Est Comp Date	Amount of Contract	% of Bid	
Airport Contractors Services 407.722.1735 540 North State Rd. 434, Unit 9501 Altomante Springs, FL 32714 FEIN: 94-3453943	Female Owned	Specialty equipment supplier	Per Contract	Per Contract	\$1,945,000 Estimated	75% Estimated	
			* ACS is a Certified Supplier, so per DBE Regulations, only 60% of the Contract value qualifies as DBE Participation. Thus, with Contract value of \$1,945,000, \$1,167,000 (60%) will qualify as DBE participation. This is estimated as 46% DBE Participation over entire Bid value for Contract 1039-GC				
The Bidder will enter into a formal agreement with the DBE firm(s) listed in this schedule conditioned upon execution of a contract with the Albany County Airport Authority			 Signature		6/2/2020 Date		

CONTRACTOR'S CERTIFICATION OF NONSEGREGATED FACILITIES

The federally assisted construction contractor certifies that it does not maintain or provide, for its employees, any segregated facilities at any of its establishments and that it does not permit employees to perform services at any location, under its control, where segregated facilities are maintained. The federally assisted construction contractor certifies that it will not maintain or provide, for its employees, segregated facilities at any of its establishments and that it will not permit its employees to perform services at any location, under its control where segregated facilities are maintained. The federally assisted construction contractor agrees that a breach of this certification is a violation of the equal opportunity clause in this contract. As used in this certification, the term Asegregated facilities@ means any waiting rooms, work areas, restrooms and washrooms, restaurants and other eating areas, time clocks, locker rooms and other storage or dressing areas, parking lots, drinking fountains, recreation or entertainment areas, transportation and housing facilities provided for employees which are segregated by explicit directives or are in fact segregated on the basis of race, color, religion or national origin because of habit, local custom, or any other reason. The federally assisted construction contractor agrees that (except where he has obtained identical certifications from proposed subcontractors for specific time periods) he will obtain identical certifications for proposed subcontractors prior to the award of subcontractors exceeding \$10,000.00 which are not exempt from the provisions of the equal opportunity clause and that he will retain such certifications in his files.

The information above is true and complete to the best of my knowledge.

Jay Grantham - President
Name and Title (Please type)

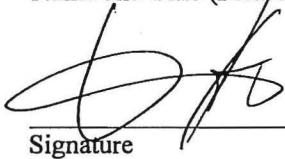
Signature

Date 6/2/2020

Note: The penalty for making false statements in offers is prescribed in 18 U.S.C. 1001.

CONTRACTOR'S CERTIFICATION OF ELIGIBILITY

The bidder certifies, by submission of this proposal or acceptance of this contract, that neither it nor its principals is presently debarred, suspended, proposed for debarment, declared ineligible, or voluntarily excluded from participation in this transaction by any Federal department or agency. It further agrees by submitting this bid that it will include this clause without modification in all lower tier transactions, solicitations, bids, proposals, contracts, and subcontracts. Where the bidder/offer/contractor or any lower tier participant is unable to certify to this statement, it shall attach an explanation to this solicitation/proposal.

The information above is true and complete to the best of my knowledge.

Jay Grantham - President

Name and Title (please print)

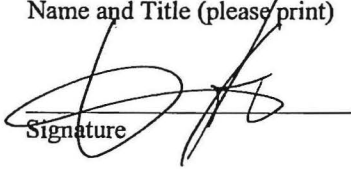
Signature

6/2/2020

Date

Note: The penalty for making false statements in offers is prescribed in 19 U.S.C. 1001.

Buy American Waivers Issued list.

A bidder or offeror must submit the appropriate Buy America certification (below) with all bids or offers on AIP funded projects. Bids or offers that are not accompanied by a completed Buy America certification must be rejected as nonresponsive.

2. Type of Certification is Based on Type of Project

There are two types of Buy American certifications.

- For projects for a facility, the *Certificate of Compliance Based on Total Facility (Terminal or Building Project)* must be submitted.
- For all other projects, the *Certificate of Compliance Based on Equipment and Materials Used on the Project (Non-building heavy construction projects such as runway or roadway construction; or equipment acquisition projects)* must be submitted.

Certificate of Compliance Based on Total Facility (Terminal or Building Project)

By submitting a bid/proposal under this solicitation, the bidder or offeror certifies that the facility will be constructed of United States steel, and at least 60% of all of the components and subcomponents of manufactured goods used in the facility will be of United States origin. The cost of labor involved in final assembly at the jobsite is excluded from the calculation of component and subcomponent cost.

The bidder or offeror further certifies that it has listed all non-US origin materials, the costs for these manufactured goods, and the percentage of cost of non-US origin materials (excluding the cost of labor involved in final assembly at the jobsite) below unless 1) the product is listed as an Excepted Article, Material Or Supply in Federal Acquisition Regulation subpart 25.108; 2) the FAA has issued a waiver for the product, as indicated by its inclusion in the FAA Nationwide Buy American Waivers Issued list. Components of unknown origin are considered to have been produced or manufactured outside the United States.

For those items listed below by the bidder or offeror below (or on a separate and clearly identified attachment to this bid/proposal), the bidder or offeror has provided sufficient documentation to allow the sponsor to request and receive an FAA waiver for the non-US origin materials.

Product	Country of Origin	% of Total Project Cost

False Statements: Per 49 USC § 47126, this certification concerns a matter within the jurisdiction of the Federal Aviation Administration and the making of a false, fictitious or fraudulent certification may render the maker subject to prosecution under Title 18, United States Code.

Date
6/2/2020

Signature

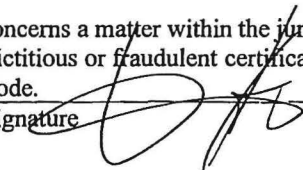

AERO BridgeWorks, Inc.
Company Name

Jay Grantham - President
Title

Certificate of Compliance Based on Equipment and Materials Used on the Project (Non-building heavy construction projects such as runway or roadway construction; or equipment acquisition projects)

By submitting a bid/proposal under this solicitation, the bidder or offeror certifies that all steel and each manufactured good proposed for use on this project are made in the United States of 100% United States materials, unless 1) the product is listed as an Excepted Article, Material Or Supply in Federal Acquisition Regulation subpart 25.108; 2) the FAA has issued a waiver for the product, as indicated by its inclusion in the FAA Nationwide Buy American Waivers Issued list, or 3) the item is listed by the bidder or offeror below or on a separate and clearly identified attachment to this bid/proposal. For those items, the bidder or offeror will provide sufficient documentation to the sponsor to allow the sponsor to request and receive an FAA waiver for the product in advance of its use on the project. If the FAA does not issue a waiver, the bidder or offeror must use manufactured goods that meet the Buy American Preference requirement.

Product	Country of Origin	% of United States Components and Subcomponents

False Statements: Per 49 USC § 47126, this certification concerns a matter within the jurisdiction of the Federal Aviation Administration and the making of a false, fictitious or fraudulent certification may render the maker subject to prosecution under Title 18, United States Code

6/2/2020

Date



Signature

AERO BridgeWorks, Inc.

Company Name

Jay Grantham - President

Title

Reference
Title 49 U.S.C. § 50101

Revised
8/12/2013

DATE: _____ DRAWN BY: _____ CHECKED BY: _____ DATE: _____

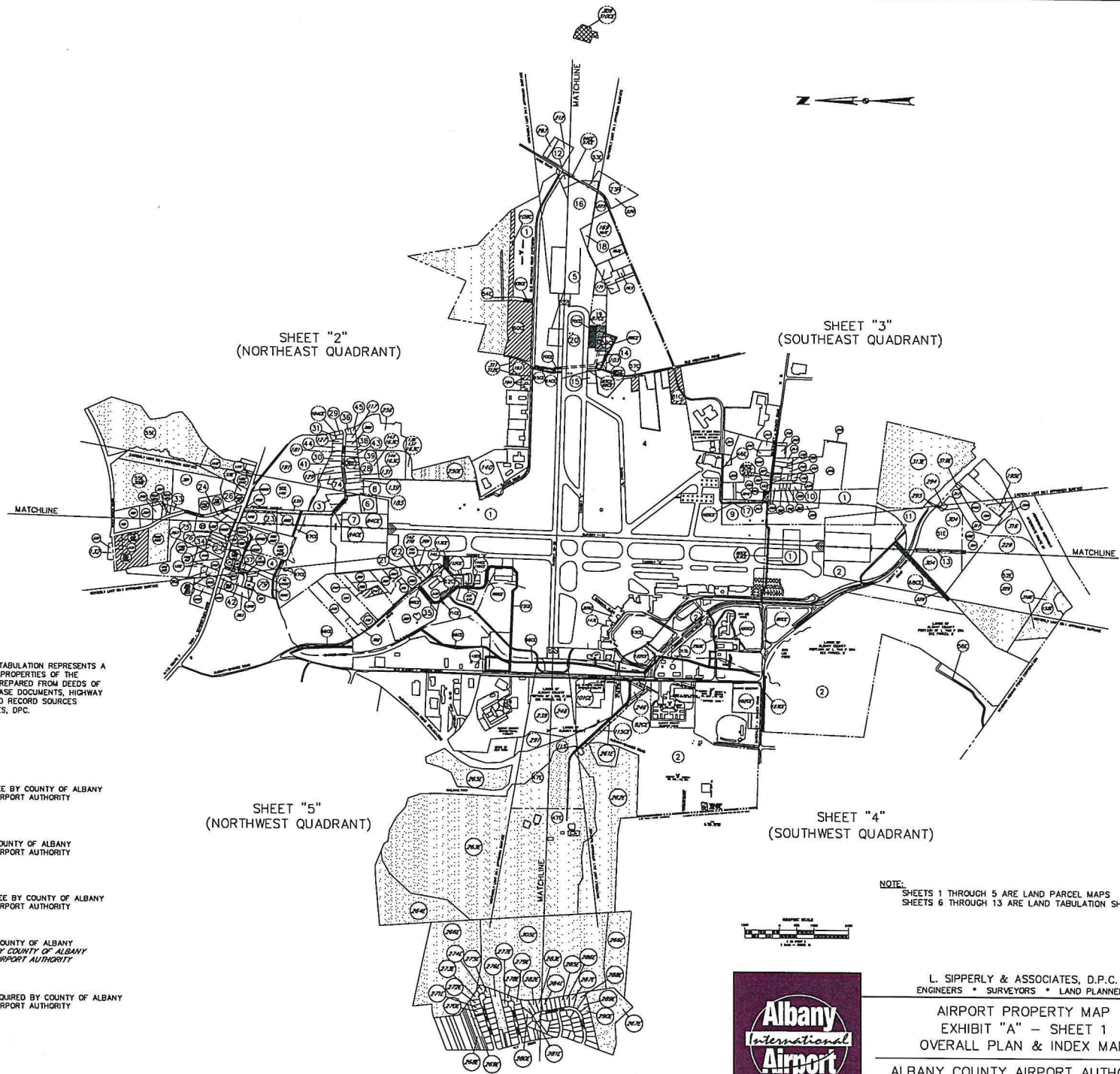

NOTE:

THIS MAP AND LAND INVENTORY DEED TABULATION REPRESENTS A COMPILATION OF LANDS, PARCELS AND PROPERTIES OF THE ALBANY COUNTY AIRPORT AUTHORITY PREPARED FROM DEEDS OF RECORD, LAND SURVEY MAPS, LAND LEASE DOCUMENTS, HIGHWAY RIGHT-OF-WAY MAPS, AND OTHER LAND RECORD SOURCES PROVIDED TO L. SIPPERLY & ASSOCIATES, D.P.C.

LEGEND:

- 1 PROPERTIES ACQUIRED IN FEE BY COUNTY OF ALBANY AND/OR ALBANY COUNTY AIRPORT AUTHORITY
- 46E EASEMENTS ACQUIRED BY COUNTY OF ALBANY AND/OR ALBANY COUNTY AIRPORT AUTHORITY
- 57C PROPERTIES CONVEYED IN FEE BY COUNTY OF ALBANY AND/OR ALBANY COUNTY AIRPORT AUTHORITY
- 63CE EASEMENTS CONVEYED BY COUNTY OF ALBANY OR ON PROPERTY OWNED BY COUNTY OF ALBANY AND/OR ALBANY COUNTY AIRPORT AUTHORITY
- 73R RESTRICTIVE COVENANTS ACQUIRED BY COUNTY OF ALBANY AND/OR ALBANY COUNTY AIRPORT AUTHORITY

NOTE:
SHEETS 1 THROUGH 5 ARE LAND PARCEL MAPS
SHEETS 6 THROUGH 13 ARE LAND TABULATION SHEETS



LAST REVISED: 1/31/19

L. SIPPERLY & ASSOCIATES, D.P.C.
ENGINEERS • SURVEYORS • LAND PLANNERS



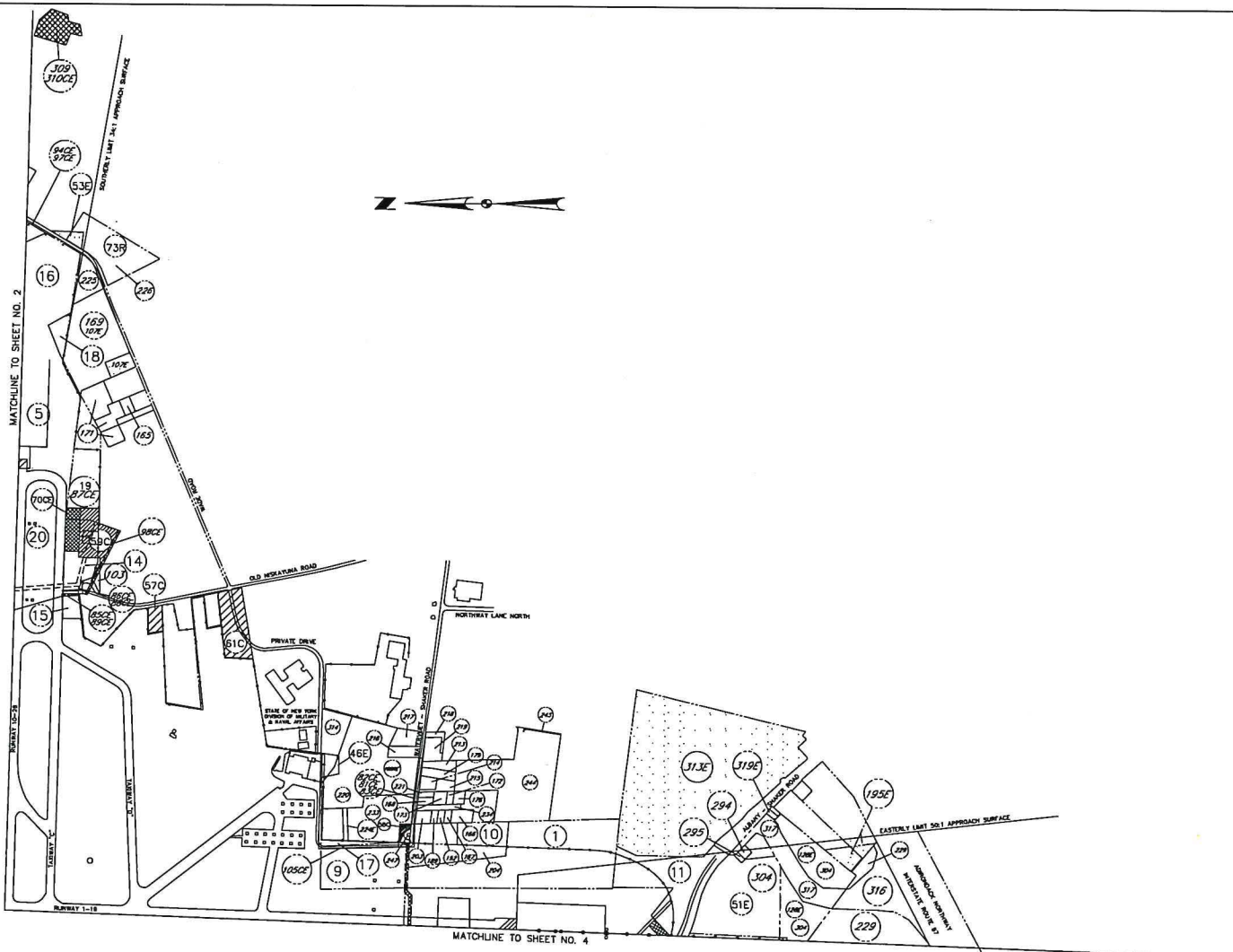

AIRPORT PROPERTY MAP
EXHIBIT "A" - SHEET 1
OVERALL PLAN & INDEX MAP

ALBANY COUNTY AIRPORT AUTHORITY
ALBANY, NEW YORK

DIVISION OF SURVEYING AND MAPPING
 COUNTY OF ALBANY
 AIRPORT PROPERTY MAP



LEGEND:

- 
 PROPERTIES ACQUIRED IN FEE BY COUNTY OF ALBANY AND/OR ALBANY COUNTY AIRPORT AUTHORITY
- 
 EASEMENTS ACQUIRED BY COUNTY OF ALBANY AND/OR ALBANY COUNTY AIRPORT AUTHORITY
- 
 PROPERTIES CONVEYED IN FEE BY COUNTY OF ALBANY AND/OR ALBANY COUNTY AIRPORT AUTHORITY
- 
 EASEMENTS CONVEYED BY COUNTY OF ALBANY OR ON PROPERTY OWNED BY COUNTY OF ALBANY AND/OR ALBANY COUNTY AIRPORT AUTHORITY
- 
 RESTRICTIVE COVENANTS ACQUIRED BY COUNTY OF ALBANY AND/OR ALBANY COUNTY AIRPORT AUTHORITY

NOTE:

THIS MAP AND LAND INVENTORY DEED TABULATION REPRESENTS A COMPILATION OF LANDS, PARCELS AND PROPERTIES OF THE ALBANY COUNTY AIRPORT AUTHORITY PREPARED FROM DEEDS OF RECORD, LAND SURVEY MAPS, LAND LEASE DOCUMENTS, HIGHWAY RIGHT-OF-WAY MAPS, AND OTHER LAND RECORD SOURCES PROVIDED TO L. SIPPERLY & ASSOCIATES, D.P.C.

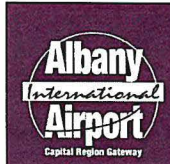

L. SIPPERLY & ASSOCIATES, D.P.C.
 ENGINEERS • SURVEYORS • LAND PLANNERS
AIRPORT PROPERTY MAP
EXHIBIT "A" - SHEET 3
SOUTHEAST QUADRANT

 ALBANY COUNTY AIRPORT AUTHORITY
 ALBANY, NEW YORK

LAST REVISED: 1/31/19

DIVISION OF PLANNING AND COMMUNITY DEVELOPMENT
 COUNTY OF ALBANY
 AIRPORT AUTHORITY

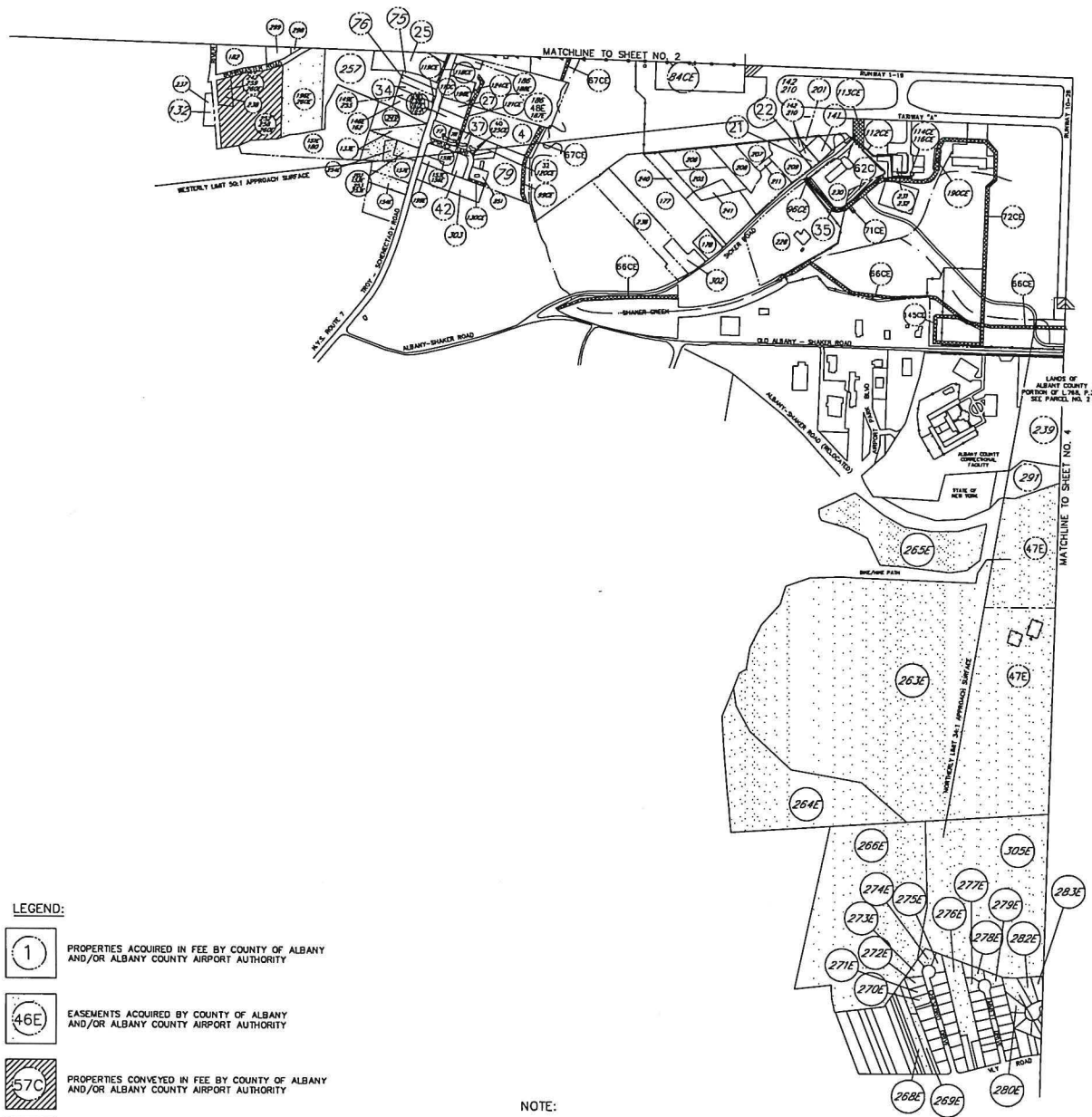

LEGEND:

- PROPERTIES ACQUIRED IN FEE BY COUNTY OF ALBANY AND/OR ALBANY COUNTY AIRPORT AUTHORITY
- EASEMENTS ACQUIRED BY COUNTY OF ALBANY AND/OR ALBANY COUNTY AIRPORT AUTHORITY
- PROPERTIES CONVEYED IN FEE BY COUNTY OF ALBANY AND/OR ALBANY COUNTY AIRPORT AUTHORITY
- EASEMENTS CONVEYED BY COUNTY OF ALBANY OR ON PROPERTY OWNED BY COUNTY OF ALBANY AND/OR ALBANY COUNTY AIRPORT AUTHORITY
- RESTRICTIVE COVENANTS ACQUIRED BY COUNTY OF ALBANY AND/OR ALBANY COUNTY AIRPORT AUTHORITY

NOTE:

THIS MAP AND LAND INVENTORY DEED TABULATION REPRESENTS A COMPILED OF LANDS, PARCELS AND PROPERTIES OF THE ALBANY COUNTY AIRPORT AUTHORITY PREPARED FROM DEEDS OF RECORD, LAND SURVEY MAPS, LAND LEASE DOCUMENTS, HIGHWAY RIGHT-OF-WAY MAPS, AND OTHER LAND RECORD SOURCES PROVIDED TO L. SIPPERLY & ASSOCIATES, D.P.C.

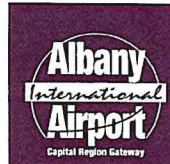

L. SIPPERLY & ASSOCIATES, D.P.C.
 ENGINEERS • SURVEYORS • LAND PLANNERS
AIRPORT PROPERTY MAP
EXHIBIT "A" – SHEET 5
NORTHWEST QUADRANT

 ALBANY COUNTY AIRPORT AUTHORITY
 ALBANY, NEW YORK

LAST REMSED: 1/31/19

PARCEL NO.	GRANTOR	GRANTEE	DEED DATE	RECORDED	AREA (AC.+/-)	REMARKS
1	CITY OF ALBANY	COUNTY OF ALBANY	OCT. 10, 1960	L 1664 P 229	682	PORTION OF SOUTHWEST CORNER OF THIS PARCEL CURRENTLY LEASED TO ENGEL FOR AGRICULTURAL PURPOSES.
2	THOMAS B. BERGAN	COUNTY OF ALBANY	DEC. 22, 1925	L 768 P 394	8.9	PORTION OF DEED
3	PHILIP C. AND MARY A. VEDDER	COUNTY OF ALBANY	FEB. 21, 1961	L 1675 P 473	1.2	
4	JOSEPH C. AND JULE VANWINKLE	COUNTY OF ALBANY	FEB. 27, 1961	L 1676 P 167	4	
5	ROSE, ELIZABETH, ANNA, LOUISE AND THERESA RUFF	COUNTY OF ALBANY	MAR. 1, 1961	L 1676 P 371	18	
6	GRACE GUINAN	COUNTY OF ALBANY	APR. 5, 1961	L 1679 P 211	2	
7	CITY OF ALBANY	COUNTY OF ALBANY	MAY 12, 1961	L 1682 P 421	0.5	
8	DAVID J. AND ROSE A. ROBILLARD	COUNTY OF ALBANY	MAY 23, 1961	L 1683 P 391	0.9	
9	RAYMOND SCHULTZ	COUNTY OF ALBANY	DEC. 14, 1964	L 1816 P 185	7.3	
10	PAUL F. PEETS	COUNTY OF ALBANY	JULY 13, 1966	L 1875 P 183	5.4	
11	E. WALTER ENGEL	COUNTY OF ALBANY	JULY 15, 1966	L 1875 P 237	9.6	PORTION OF THIS PARCEL CURRENTLY LEASED TO ENGEL FOR AGRICULTURAL PURPOSES
12	THEODORE W. AND MARJORIE H. PRINCE	COUNTY OF ALBANY	AUG. 14, 1973	L 2069 P 271	1.3	
13	E. WALTER AND ELIZABETH ENGEL	COUNTY OF ALBANY	SEPT. 6, 1974	L 2087 P 223	1	
14	LOUISA B. HELLWIG	COUNTY OF ALBANY	APR. 10, 1974	L 2079 P 775	3.9	SEE PARCEL NO. 57C
15	JOHN F. A. AND LOUISA B. HELLWIG	COUNTY OF ALBANY	APR. 3, 1975	L 2096 P 155	0.8	SEE PARCEL NO. 64CE
16	COUNCIL COMMERCE CORPORATION	COUNTY OF ALBANY	NOV. 24, 1975	L 2109 P 215	6.2	
17	CONN REALTY CORPORATION	COUNTY OF ALBANY	DEC. 30, 1977	L 2143 P 1061	0.3	LAND SWAP; SEE PARCEL NO. 58C
18	JOHN J. AND ELIZABETH ANN HUBAN	COUNTY OF ALBANY	JUNE 20, 1979	L 2171 P 407	0.6	
19	CATHERINE M. FISH	COUNTY OF ALBANY	FEB. 3, 1980	L 2183 P 309	6.1	
20	TOWN OF COLONIE	COUNTY OF ALBANY	MAR. 18, 1980	L 2185 P 1149	6.8	CORRECTIVE DEED - 2084 / 337
21	ROBERT W., SR. AND CATHERINE S. HACKEL	COUNTY OF ALBANY	MAY 29, 1981	L 2206 P 317	0.3	F. A. A. NOISE ABATEMENT GRANT; FEDERAL PROJ. NO. 6-36-0001-09
22	ROBERT W. HACKEL	COUNTY OF ALBANY	MAY 29, 1981	L 2206 P 319	0.4	F. A. A. NOISE ABATEMENT GRANT; FEDERAL PROJ. NO. 6-36-0001-09
23	HONIGSBAUM'S INC., ET. AL.	COUNTY OF ALBANY	OCT. 1, 1981	L 2195 P 1075	4.7	ACQUIRED BY EMINENT DOMAIN, COURT RECORDS INDEX NO. 8891-81. F. A. A. NOISE ABATEMENT GRANT; FED. PROJ. NO. 6-36-0001-09. ALSO, PREV. AVIGATION EASEMENT L. 1643 P. 481
24	CAROLINE B. KNAPP	COUNTY OF ALBANY	OCT. 7, 1981	L 2213 P 839	1.0	F. A. A. NOISE ABATEMENT GRANT; FEDERAL PROJ. NO. 6-36-0001-09
25	HELMUT L. AND GLORIA SALISBURY SCHMEICHEL	COUNTY OF ALBANY	JULY 14, 1982	L 2225 P 701	4	F. A. A. NOISE ABATEMENT GRANT; FEDERAL PROJ. NO. 6-36-0001-09
26	ESTATE OF IRVING I. BUHRMASTER	COUNTY OF ALBANY	SEPT. 28, 1983	L 2247 P 157	3.5	F. A. A. NOISE ABATEMENT GRANT; FEDERAL PROJ. NO. 6-36-0001-09
27	JULE VAN WINKLE	COUNTY OF ALBANY	MAR. 9, 1984	L 2257 P 479	0.5	F. A. A. NOISE ABATEMENT GRANT; FEDERAL PROJ. NO. 6-36-0001-09
28	W. GLENN AND MARGARET A. BALDWIN	COUNTY OF ALBANY	JAN. 4, 1985	L 2276 P 403	1	F. A. A. NOISE ABATEMENT GRANT; FEDERAL PROJ. NO. 6-36-0001-09
29	MICHAEL J. GERRITY AND OTHERS	COUNTY OF ALBANY	JUNE 28, 1985	L 2294 P 995	0.3	F. A. A. NOISE ABATEMENT GRANT; FEDERAL PROJ. NO. 6-36-0001-04-84
30	MARY BEER	COUNTY OF ALBANY	NOV. 25, 1985	L 2297 P 865	0.4	F. A. A. NOISE ABATEMENT GRANT; FEDERAL PROJ. NO. 6-36-0001-04-84
31	HARRY M. KELLY AND RUTH C. BARBAGALLO	COUNTY OF ALBANY	JAN. 29, 1986	L 2303 P 159	0.3	F. A. A. NOISE ABATEMENT GRANT; FEDERAL PROJ. NO. 6-36-0001-04-84
32	JOHN E. AND THEA M. GRAHAM	COUNTY OF ALBANY	MAR. 5, 1986	L 2305 P 309	0.5	F. A. A. NOISE ABATEMENT GRANT; FEDERAL PROJ. NO. 6-36-0001-04-84
33	FOSTER C. AND DOROTHY A. GOODALE	COUNTY OF ALBANY	APR. 9, 1986	L 2308 P 123	0.5	F. A. A. NOISE ABATEMENT GRANT; FEDERAL PROJ. NO. 3-36-0001-07-85
34	DR. BASAVARAJA DREKONDY	COUNTY OF ALBANY	OCT. 1, 1986	L 2322 P 565	0.4	F. A. A. NOISE ABATEMENT GRANT; FEDERAL PROJ. NO. 6-36-0001-09
35	ALBANY COUNTY IDA AND COMMAND AIRWAYS, INC.	COUNTY OF ALBANY	NOV. 20, 1986	L 2335 P 729	0.7	
36	TIMOTHY FREDERICK	COUNTY OF ALBANY	DEC. 31, 1986	L 2328 P 832	0.1	F. A. A. NOISE ABATEMENT GRANT; FEDERAL PROJ. NO. 6-36-0001-04-84
37	JAMES T. AND LISA A. HOFFMAN	COUNTY OF ALBANY	JUNE 15, 1990	L 2417 P 285	0.3	F. A. A. NOISE ABATEMENT GRANT; FEDERAL PROJ. NO. 6-36-0001-04-84
38	SCOTT A. AND JANET L. McCLOUD	COUNTY OF ALBANY	JULY 17, 1990	L 2419 P 593	0.6	F. A. A. NOISE ABATEMENT GRANT; FEDERAL PROJ. NO. 6-36-0001-04-84
39	HERBERT AND PATRICIA E. LEICHMAN	COUNTY OF ALBANY	SEPT. 20, 1990	L 2423 P 721	0.7	F. A. A. NOISE ABATEMENT GRANT; FEDERAL PROJ. NO. 6-36-0001-09
40	LORENZINA MASTROIANNI	COUNTY OF ALBANY	SEPT. 21, 1990	L 2423 P 855	0.4	F. A. A. NOISE ABATEMENT GRANT; FEDERAL PROJ. NO. 6-36-0001-04-84
41	VIVIAN PAIGE	COUNTY OF ALBANY	OCT. 26, 1990	L 2425 P 1053	0.8	F. A. A. NOISE ABATEMENT GRANT; FEDERAL PROJ. NO. 6-36-0001-09
42	FRANK A. AND DOREEN L. VALCIK	COUNTY OF ALBANY	NOV. 27, 1990	L 2427 P 847	0.5	F. A. A. NOISE ABATEMENT GRANT; FEDERAL PROJ. NO. 6-36-0001-04-84
43	TOH MING LU AND GWO CHING WANG	COUNTY OF ALBANY	NOV. 30, 1990	L 2427 P 1105	0.6	F. A. A. NOISE ABATEMENT GRANT; FEDERAL PROJ. NO. 6-36-0001-04-84
44	DAVID JESMAIN	COUNTY OF ALBANY	DEC. 12, 1990	L 2428 P 845	0.7	F. A. A. NOISE ABATEMENT GRANT; FEDERAL PROJ. NO. 6-36-0001-04-84
45	BOOTH W. AND DALE M. UPTON	COUNTY OF ALBANY	JAN. 25, 1991	L 2431 P 335	0.3	F. A. A. NOISE ABATEMENT GRANT; FEDERAL PROJ. NO. 6-36-0001-04-84

NOTE:

THIS MAP AND LAND INVENTORY DEED TABULATION REPRESENTS A COMPILATION OF LANDS, PARCELS AND PROPERTIES OF THE ALBANY COUNTY AIRPORT AUTHORITY PREPARED FROM DEEDS OF RECORD, LAND SURVEY MAPS, LAND LEASE DOCUMENTS, HIGHWAY RIGHT-OF-WAY MAPS, AND OTHER LAND RECORD SOURCES PROVIDED TO L. SIPPERLY & ASSOCIATES, D.P.C.



L. SIPPERLY & ASSOCIATES, D.P.C.
ENGINEERS • SURVEYORS • LAND PLANNERS

AIRPORT PROPERTY MAP
EXHIBIT "A" - SHEET 6
LAND TABULATION

ALBANY COUNTY AIRPORT AUTHORITY
ALBANY, NEW YORK

LAST REVISED: 1/31/19

PARCEL NO.	GRANTOR	GRANTEE	DEED DATE	RECORDED	AREA	REMARKS
46E	HAVELOCK AND LILLIE PRIMETT	CITY OF ALBANY	MAY 1, 1940	L 915 P 416	0.4	CLEARANCE EASEMENT
47E	SHAKER RIDGE COUNTRY CLUB, INC.	CITY OF ALBANY	DEC. 28, 1951	L 1296 P 176	107.5	AVIGATION EASEMENT 33' 1 PLANE
48E	VERDDY VOLUNTEER FIRE ASSOCIATION, INC.	CITY OF ALBANY	APR. 4, 1960	L 1645 P 197	7.8	AVIGATION EASEMENT; MINIMUM HEIGHT RESTRICTIONS APPLY
49E	JOSEPH C. AND JULE VanWINKLE	COUNTY OF ALBANY	FEB. 27, 1961	L 1676 P 161	1.5	AVIGATION EASEMENT; MINIMUM HEIGHT RESTRICTIONS APPLY
50E	WILLIAM H. REBUSMEN	COUNTY OF ALBANY	OCT. 2, 1961	L 1700 P 48	17.0	AVIGATION EASEMENT; MINIMUM HEIGHT RESTRICTIONS APPLY
51E	E. WALTER AND ELIZABETH ENGEL	COUNTY OF ALBANY	JULY 15, 1966	L 1875 P 371	27.8	AVIGATION EASEMENT; MINIMUM HEIGHT RESTRICTIONS APPLY
52E	TRI - CITY INDUSTRIES, INC.	COUNTY OF ALBANY	JAN. 6, 1975	L 2093 P 79	57.1	AIR EASEMENT; MINIMUM HEIGHT RESTRICTIONS APPLY; ALSO SEE PARCEL NO. 68CE
53E	COUNCIL COMMERCE CORPORATION	COUNTY OF ALBANY	DEC. 17, 1975	L 2109 P 267	0.3	AIR EASEMENT; MINIMUM HEIGHT RESTRICTIONS APPLY
54E	JAMES W. AND HELEN COTON	COUNTY OF ALBANY	DEC. 7, 1979	L 2180 P 922	50	AIR EASEMENT; MINIMUM HEIGHT RESTRICTIONS APPLY; EXCHANGE OF EASEMENTS; SEE PARCEL NO. 69CE
55E	ESTATE OF IRVING F. BUHRMASTER	COUNTY OF ALBANY	SEPT. 28, 1983	L 2247 P 179	81	AIR EASEMENT; MINIMUM HEIGHT RESTRICTIONS APPLY
56E	ASHFIELD ASSOCIATES	COUNTY OF ALBANY	DEC. 10, 1990	L 2428 P 969	---	30' WIDE EASEMENT FOR WASTE GLYCOL SEWER MAIN

PARCEL NO.	GRANTOR	GRANTEE	DEED DATE	RECORDED	AREA (AC.+/-)	REMARKS
57C	COUNTY OF ALBANY	JOHN F. A. AND LOUISA B. HELLWIG	APR. 3, 1975	L 2096 P 145	0.8	
58C	COUNTY OF ALBANY	CDNN REALTY CORPORATION	DEC. 20, 1977	L 2143 P 1119	0.3	LAND SWAP; SEE PARCEL NO. 17
59C	COUNTY OF ALBANY	TOWN OF COLONIE	APR. 2, 1980	L 2185 P 1153	2.4	SEE PARCEL NO. 70CE
60C	COUNTY OF ALBANY	PEPSI-COLA ALBANY BOTTLING CO, INC	NOV. 2, 1982	L 2230 P 1035	4.8	SUBJECT TO RESTRICTIVE COVENANTS; ALSO, SEE PARCEL NO. 69CE
61C	COUNTY OF ALBANY	THE PEOPLE OF THE STATE OF NEW YORK	AUG. 27, 1984	L 2268 P 193	3.6	SUBJECT TO RIGHTS OF REVERTER TO COUNTY OF ALBANY
62C	COUNTY OF ALBANY	COMMAND AIRWAYS, INC.	OCT. 30, 1986	L 2335 P 723	0.4	SEE PARCEL NO. 71CE
63CE	COUNTY OF ALBANY	NIAGARA MOHAWK POWER CORP.	DEC. 13, 1965	L 1858 P 341	---	10' WIDE RIGHT OF WAY AND EASEMENT FOR GAS MAIN
64CE	LOUISA B. AND JOHN F. A. HELLWIG	TOWN OF COLONIE	NOV. 19, 1973	L 2062 P 267	---	SANITARY SEWER EASEMENT
65CE	COUNTY OF ALBANY	TOWN OF COLONIE	DEC. 3, 1973	L 2075 P 263	---	SANITARY SEWER EASEMENT
66CE	COUNTY OF ALBANY	TOWN OF COLONIE	DEC. 3, 1973	L 2075 P 266	---	SANITARY SEWER EASEMENT
67CE	COUNTY OF ALBANY	TOWN OF COLONIE	DEC. 3, 1973	L 2075 P 323	---	SANITARY SEWER EASEMENT
68CE	COUNTY OF ALBANY	TRI-CITY INDUSTRIES, INC.	JAN. 6, 1975	L 2093 P 79	---	EASEMENT AND RIGHT OF WAY FOR INGRESS, EGRESS AND UTILITIES INSTALLATION; ALSO, SEE PARCEL NO. 52E
69CE	COUNTY OF ALBANY	JAMES W. AND HELEN COTON	DEC. 7, 1979	L 2180 P 922	---	EASEMENT AND RIGHT OF WAY FOR INGRESS, EGRESS AND UTILITIES INSTALLATION; CORRECTIVE DEED L 2230 P 1033 ISSUED NOV. 2 1982 TO PEPSI-COLA ALBANY BOTTLING CO, INC. OVER SAME PARCEL; ALSO, SEE PARCEL NO. 60C
70CE	COUNTY OF ALBANY	TOWN OF COLONIE	APR. 2, 1980	L 2185 P 1153	---	PROTECTIVE EASEMENT AND WATER MAIN EASEMENT; ALSO, SEE PARCEL 59C
71CE	COUNTY OF ALBANY	COMMAND AIRWAYS, INC.	OCT. 30, 1986	L 2335 P 723	---	DRAINAGE EASEMENT AND RIGHT TO CLEAR EXISTING DITCH FOR DRAINAGE; ALSO, SEE PARCEL 62C
72CE	COUNTY OF ALBANY	TOWN OF COLONIE	OCT. 26, 1990	L 2427 P 79	---	WATER MAIN EASEMENT
73R	COUNCIL COMMERCE CORPORATION	COUNTY OF ALBANY	NOV. 24, 1975	L 2109 P 221	---	RESTRICTIVE COVENANTS ON THIS PARCEL CONCERNING AIR AND NOISE POLLUTION
74	EUGENE P. DEVINE, CO. TREAS. FOR THE COUNTY OF ALBANY	COUNTY OF ALBANY	SEPT. 14, 1966	L 1883 P 51	0.9	FORMERLY OWNED BY EMILY HARGRAVES. ALBANY COUNTY FORECLOSED FOR DELINQUENT TAXES. JURISDICTION REPUTEDLY TRANSFERRED FROM ALBANY CO. REAL PROPERTY TO ALBANY CO. AIRPORT FEB. 1987.

NOTE:

THIS MAP AND LAND INVENTORY DEED TABULATION REPRESENTS A COMPILATION OF LANDS, PARCELS AND PROPERTIES OF THE ALBANY COUNTY AIRPORT AUTHORITY PREPARED FROM DEEDS OF RECORD, LAND SURVEY MAPS, LAND LEASE DOCUMENTS, HIGHWAY RIGHT-OF-WAY MAPS, AND OTHER LAND RECORD SOURCES PROVIDED TO L. SIPPERLY & ASSOCIATES, D.P.C.



L. SIPPERLY & ASSOCIATES, D.P.C.
ENGINEERS • SURVEYORS • LAND PLANNERS

AIRPORT PROPERTY MAP
EXHIBIT "A" - SHEET 7
LAND TABULATION

ALBANY COUNTY AIRPORT AUTHORITY
ALBANY, NEW YORK

LAST REVISED: 1/31/19

PARCEL NO.	GRANTOR	GRANTEE	DEED DATE	RECORDED	AREA (AC+/-)	REMARKS
75	RONALD A. MINCH & LEATRICE H. FONDA	COUNTY OF ALBANY	OCT. 10, 1991	L.2446 P.574	---	8.03-1-53
76	DOUGLAS H. & DOROTHY R. CADY	COUNTY OF ALBANY	SEPT. 19, 1991	L.2445 P. 33	---	8.03-1-52
77	SACHA F. PERCENT	COUNTY OF ALBANY	JUNE 29, 1993	L.2486 P. 501	---	18.00-2-21
78	JACK C.F. JANG	COUNTY OF ALBANY	MAR. 22, 1991	L.2434 P. 241	---	18.00-2-20
79	YVONNE SGAMBELLURI	COUNTY OF ALBANY	SEPT. 2, 1993	L.2491 P. 669	---	18.00-2-16
80CE	COUNTY OF ALBANY	N.Y. POWER & LIGHT CO.	MAY 17, 1928	L.811 P. 74	---	PARCEL 2 / ELEC LINE ESMT.
81CE	LOUIS & ANNA SCHULTZ	N.Y. POWER & LIGHT CO.	APRIL 11, 1929	L.813 P. 275	---	PARCEL 9 / ELEC LINE ESMT.
82CE	LOUIS & ANNA SCHULTZ	N.Y. POWER & LIGHT CO.	APRIL 23, 1929	L.825 P. 220	---	PARCEL 17 / ELEC LINE ESMT.
83CE	LOUIS & ANNA SCHULTZ	N.Y. POWER & LIGHT CO.	MARCH 18, 1930	L.825 P. 407	---	PARCEL 9 / ELEC LINE ESMT.
84CE	ROBERT P. KELLY	N.Y. POWER & LIGHT CO.	SEPT. 25, 1934	L.871 P. 227	---	PARCEL 1 - 50 PINEGROVE / ELEC LINE ESMT.
85CE	JOHN W. HELLWIG	N.Y. POWER & LIGHT CO.	SEPT. 5, 1935	L.873 P. 367	---	PARCEL 15 / ELEC LINE ESMT.
86CE	HARVEY S. & TILLIE H. BAUMES	N.Y. POWER & LIGHT CO.	JAN. 9, 1942	L.938 P. 359	---	PARCEL 14 / ELEC LINE ESMT.
87CE	KATHERINE X. RUF	N.Y. POWER & LIGHT CO.	JUNE 10, 1942	L.938 P. 361	---	PARCEL 19 / ELEC LINE ESMT.
88CE	HARVEY S. & TILLIE H. BAUMES	N.Y. POWER & LIGHT CO.	DEC. 28, 1951	L.1296 P. 75	---	PARCEL 1 / ELEC LINE ESMT.
89CE	JOHN HELLWIG	N.Y. TELEPHONE CO.	DEC. 21, 1951	L.1300 P. 103	---	PARCEL 15 / TEL LINE ESMT.
90CE	FRANCIS E. LOGAN	N.Y. TELEPHONE CO.	MAY 13, 1960	L.1659 P. 217	---	PARCEL 1 / U/G TEL ESMT.
91CE	WILLIAM H. REBUSMEN	LATHAM WATER DISTRICT	AUG. 8, 1961	L.1692 P. 231	---	PARCEL 50E / WATER LINE ESMT.
92CE	COUNTY OF ALBANY	NIAGARA MOHAWK POWER CORP.	JUNE 14, 1966	L.1858 P. 337	---	PARCEL 47E / GAS LINE ESMT.
93CE	COUNTY OF ALBANY	CITY OF WATERVLIET, N.Y.	AUG. 10, 1966	L.1878 P. 313	---	PARCEL 1 / WATER LINE ESMT.
94CE	THEODORE & MARJORIE PRINCE	NIAGARA MOHAWK POWER CORP.	OCT. 29, 1968	L.1958 P. 23	---	PARCEL 12 / GAS LINE ESMT.
95CE	JAMES RADLEY	N.Y. TELEPHONE CO.	AUG. 4, 1969	L.1983 P. 195	---	PARCEL 23 / U/G TELEPHONE ESMT.
96CE	A.H. HARRIS & SONS, INC.	N.Y. TELEPHONE CO.	JULY 1, 1970	L.2013 P. 18	---	PARCEL 35 / U/G TELEPHONE ESMT.
97CE	THEODORE M. & MARJORIE M. PZENICZNY	TOWN OF COLONIE	MAY 11, 1973	L.2063 P. 817	---	PARCEL 12 / SEWER LINE ESMT.
98CE	COUNTY OF ALBANY	ANNA, LOUISE, & THERESA RUF	JULY 12, 1974	L.2084 P. 335	---	PARCEL 59C / RESERVES INGRESS/EGRESS ESMT.
99CE	YVONNE SGAMBELLURI	TOWN OF COLONIE	JULY 21, 1975	L.2101 P. 199	---	PARCEL 79 / SEWER LINE ESMT.
100CE	COUNTY OF ALBANY	NIAGARA MOHAWK POWER CORP.	JAN. 5, 1977	L.2125 P. 631	---	ANN LEE PROP. / U/G ELEC ESMT.
101CE	COUNTY OF ALBANY	TOWN OF COLONIE	JAN. 19, 1977	L.2126 P. 317	---	ALBANY-SHAKER RD / WATER ESMT.
102CE	COUNTY OF ALBANY	NIAGARA MOHAWK POWER CORP.	FEB. 15, 1977	L.2127 P. 245	---	PARCEL 2 / ALBANY-SHAKER WEST OF AIRPORT / ELEC LINE ESMT.
103	TURF CONSTRUCTION CO. INC.	COUNTY OF ALBANY	APRIL 11, 1977	L.2129 P. 1159	---	18.00-4-6.1
104CE	JOSEPH WUNDERLICH	TOWN OF COLONIE	NOV. 4, 1977	L.2140 P. 1097	---	PARCEL 29 / SEWER
105CE	FRANK MARKUS	NIAGARA MOHAWK & N.Y. TELEPHONE	NOV. 25, 1977	L.2142 P. 63	---	PARCELS 1,9,17 / U/G ELEC & TEL ESMT.
106CE	KENNETH A. & BARBARA R. REBUSMEN	TOWN OF COLONIE	JUNE 7, 1978	L.2150 P. 1059	---	PARCEL 50E / WATER ESMT.
107E	JOHN J. & ELIZABETH A. HUBAN	COUNTY OF ALBANY	JUNE 28, 1979	L.2171 P. 445	---	18.00-4-25.1 / AIR ESMT.
108RE	COUNTY OF ALBANY	WARREN SCHULTZ	DEC. 6, 1979	L.2180 P. 229	---	RELEASE AIR ESMT.
109C	COUNTY OF ALBANY	JAMES W. COTTON	DEC. 18, 1979	L.2180 P. 879	---	18.02-6-63.2
110C	COUNTY OF ALBANY	PEOPLE OF THE STATE OF NEW YORK	AUG. 8, 1990	L.2422 P. 76	---	PARCEL 27
111C	COUNTY OF ALBANY	PEOPLE OF THE STATE OF NEW YORK	SEPT. 7, 1990	L.2422 P. 976	---	PARCEL 23
112CE	COUNTY OF ALBANY	NIAGARA MOHAWK & N.Y. TELEPHONE	OCT. 24, 1984	L.2270 P. 636	---	PARCEL 1 / U/G ELEC & TEL TO MALL AIR
113CE	COUNTY OF ALBANY	COMMAND AIRWAYS, INC.	DEC. 20, 1984	L.2274 P. 839	---	PARCEL 1 / TAXIWAY - R.O.W. ESMT
114CE	COUNTY OF ALBANY	NIAGARA MOHAWK & N.Y. TELEPHONE	MAY 27, 1987	L.2338 P. 135	---	PARCEL 1 / U/G TEL, ELEC & GAS ESMT.
115	SHAKER RIDGE COUNTRY CLUB, INC.	COUNTY OF ALBANY	OCT. 4, 1988	L.2374 P. 293	---	RESERVES INGRESS/EGRESS ESMT & WATER LINE ESMT.
116CE	COUNTY OF ALBANY	NIAGARA MOHAWK & N.Y. TELEPHONE	MAY 8, 1989	L.2385 P. 973	---	PARCEL 1 / U/G ELEC, TEL & GAS ESMT.
117	JAMES J. & SUZZANNE RUTKOWSKI	COUNTY OF ALBANY	JUNE 12, 1991	L.2438 P. 1057	---	18.00-3-20
118CE	COUNTY OF ALBANY	TOWN OF COLONIE	JULY 22, 1991	L.2441 P. 260	---	PARCEL 25 / SEWER LINE ESMT.
119CE	COUNTY OF ALBANY	TOWN OF COLONIE	JULY 22, 1991	L.2441 P. 270	---	PARCEL 34 / SEWER LINE ESMT.

NOTE:

THIS MAP AND LAND INVENTORY DEED TABULATION REPRESENTS A COMPILATION OF LANDS, PARCELS AND PROPERTIES OF THE ALBANY COUNTY AIRPORT AUTHORITY PREPARED FROM DEEDS OF RECORD, LAND SURVEY MAPS, LAND LEASE DOCUMENTS, HIGHWAY RIGHT-OF-WAY MAPS, AND OTHER LAND RECORD SOURCES PROVIDED TO L. SIPPERLY & ASSOCIATES, D.P.C.



L. SIPPERLY & ASSOCIATES, D.P.C.
ENGINEERS • SURVEYORS • LAND PLANNERS

AIRPORT PROPERTY MAP
EXHIBIT "A" - SHEET 8
LAND TABULATION

ALBANY COUNTY AIRPORT AUTHORITY
ALBANY, NEW YORK

LAST REVISED: 1/31/19

PARCEL NO.	GRANTOR	GRANTEE	DEED DATE	RECORDED	AREA (AC.+/-)	REMARKS
120CE	COUNTY OF ALBANY	TOWN OF COLONIE	JULY 22, 1991	L.2441 P. 275	---	PARCEL 32 / SEWER LINE ESMT.
121CE	COUNTY OF ALBANY	TOWN OF COLONIE	JULY 22, 1991	L.2441 P. 279	---	PARCEL 4 / SEWER LINE ESMT.
122CE	COUNTY OF ALBANY	NIAGARA MOHAWK & N.Y. TELEPHONE	NOV. 6, 1991	L.2448 P. 101	---	PARCEL 1 / U/G ELEG & TEL ESMT.
123CE	COUNTY OF ALBANY	TOWN OF COLONIE	NOV. 19, 1991	L.2448 P. 1019	---	PARCEL 2 / SEWER LINE ESMT.
124CE	VERDDY VOLUNTEER FIRE ASSOC.	TOWN OF COLONIE	NOV. 12, 1992	L.2471 P. 1005	---	PARCEL 48E / SEWER LINE ESMT.
125CE	COUNTY OF ALBANY	TOWN OF COLONIE	NOV. 12, 1992	L.2471 P. 1010	---	PARCEL 40 / SEWER LINE ESMT.
126CE	COUNTY OF ALBANY	TOWN OF COLONIE	NOV. 12, 1992	L.2471 P. 1014	---	PARCEL 37 / SEWER LINE ESMT.
127	JOSEPH R. & JEAN B. WUNDERLICH	COUNTY OF ALBANY	APRIL 9, 1993	L.2481 P. 591	---	18.00-3-5
128E	JOHN J. & EDWARD K. ENGEL	COUNTY OF ALBANY	OCT. 18, 1993	L.2494 P. 832	---	30.00-5-1 / AIR ESMT.
129	JEAN A. LOVDO	COUNTY OF ALBANY	MARCH 15, 1994	L.2505 P. 110	---	18.00-3-16
130CE	YVONNE SGAMBELLURI	TOWN OF COLONIE	AUG. 8, 1991	L.2443 P. 455	---	PARCEL 79 / SEWER LINE ESMT.
131	MARTIN SCHMIDT	ALBANY COUNTY AIRPORT AUTHORITY	FEB. 28, 1995	L.2532 P. 208	---	18.00-3-13
132	IRENE CUSHMAN	COUNTY OF ALBANY	MAY 11, 1995	L.2533 P. 819	---	8.03-1-10
133E	ROBERT J. & JUDITH C. ZAPOLSKI	COUNTY OF ALBANY	JAN. 25, 1995	L.2527 P. 320	---	8.03-1-48.21/ AIR ESMT.
134E	MICHAEL CHRYS	ALBANY COUNTY AIRPORT AUTHORITY	MAR. 13, 1995	L.2530 P. 130	---	18.02-1-3/ AIR ESMT. // REFILED AS L.2562 P.815
135E	JANET EMPIE-PAYNE	ALBANY COUNTY AIRPORT AUTHORITY	APRIL 12, 1995	L.2531 P. 721	---	8.03-1-56/AIR ESMT.
136	INTERMAGNETICS GENERAL CORPORATION	ALBANY COUNTY AIRPORT AUTHORITY	MAR. 12, 1996	L.2552 P. 278	---	PORTION OF 18.00-3-24.2
137	ALBANY COUNTY AIRPORT AUTHORITY	COUNTY OF ALBANY	JUNE 21, 1996	L.2558 P. 863	---	PORTION OF 18.00-3-24.2
138E	MICHAEL F. & GERALD E. MANGIONE	ALBANY COUNTY AIRPORT AUTHORITY	JULY 30, 1996	L.2561 P. 115	---	18.00-2-23/ AIR ESMT. (REF. 49E - VAN WINKLE)
139	JOYCE E. GALLUP	ALBANY COUNTY AIRPORT AUTHORITY	NOV.1, 1996	L.2567 P. 772	---	18.00-3-12
140	WALTER V. & STANLEY DISTEFANO	ALBANY COUNTY AIRPORT AUTHORITY	JULY 14, 1995	L.2589 P. 85	---	18.00-3-39/IN 2448-95 R/R NO. 0195 041676
141	DAVID J. KAISER	COUNTY OF ALBANY	SEPT. 4, 1996	L.2564 P. 969	---	18.00-2-30
142	COUNTY OF ALBANY	DAVID J. KAISER	SEPT. 9, 1996	L.2564 P. 1021	---	18.00-2-31 & PORTION OF 18.00-2-29 (REF. 21 & 22)
143	BUDLONG ENTERPRISES, INC.	ALBANY COUNTY AIRPORT AUTHORITY	1996	---	---	18.00-3-23.2 (EMINENT DOMAIN)
144	JACKSON L. & RUTH B. SOTHERN	ALBANY COUNTY AIRPORT AUTHORITY	1996	---	---	18.00-3-24.12 (EMINENT DOMAIN)
145CE	COUNTY OF ALBANY	TOWN OF COLONIE	MARCH 28, 1996	L.2555 P. 442	---	WATER LINE EASEMENT - FUEL FARM
146E	LORRAINE B. SYMANSKI, ET AL.	COUNTY OF ALBANY	AUGUST 3, 1993	L.2555 P. 962	---	8.03-1-49 / AVIGATION EASEMENT
147L	ALBANY COUNTY AIRPORT AUTHORITY	CELLCO PARTNERSHIP	MAY 21, 1996	L.2560 P. 420	---	LEASE AGREEMENT - WITHIN TERMINAL BUILDING
---	COUNTY OF ALBANY	ALBANY COUNTY AIRPORT AUTHORITY	JULY 2, 1996	L.2561 P. 918	---	AIRPORT LEASE AGREEMENT
148E	ANDREW EMPIE	ALBANY COUNTY AIRPORT AUTHORITY	JUNE 3, 1996	L.2562 P. 289	---	8.03-1-57 / AVIGATION EASEMENT/ L.2562 P. 296
149E	ANNE MARIE DEMARCKEN	COUNTY OF ALBANY	SEPT. 14, 1996	L.2562 P. 769	---	8.03-1-50 / AVIGATION EASEMENT
150E	MEL WALDMAN	ALBANY COUNTY AIRPORT AUTHORITY	MARCH 22, 1996	L. 2563 P. 119	---	18.02-1-1 / AVIGATION EASEMENT
151E	NICHOLAS L. & VERA M. FRANGELLA	COUNTY OF ALBANY	APRIL 23, 1993	L.2485 P. 554	---	PORTION OF 8.03-1-48.1/AVIGATION EASEMENT
152E	ELIZABETH & CHRISTOPHER P. AMBROSE	COUNTY OF ALBANY	MAY 4, 1993	L.2485 P. 561	---	8.03-1-47/AVIGATION EASEMENT
153E	JAMES C. ANDERSON	COUNTY OF ALBANY	APRIL 27, 1993	L.2485 P. 568	---	PORTION OF 18.00-2-11/AVIGATION EASEMENT
154E	PAUL J. CITONE	COUNTY OF ALBANY	JUNE 16, 1993	L. 2585 P. 574	---	8.03-1-45/AVIGATION EASEMENT
155E	JOHN CERONE, JR.	COUNTY OF ALBANY	SEPT. 29, 1993	L.2493 P. 881	---	PORTION OF 30.00-5-10/AVIGATION EASEMENT
156E	JAMES C. ANDERSON, JR.	COUNTY OF ALBANY	AUG. 3, 1993	L.2493 P. 888	---	18.00-2-11/AVIGATION EASEMENT
157E	ESTELLE J. ELKA	COUNTY OF ALBANY	SEPT. 29, 1993	L.2495 P. 549	---	8.03-1-46/AVIGATION EASEMENT
158E	PAUL J. CITONE	COUNTY OF ALBANY	SEPT. 29, 1993	L.2496 P. 770	---	8.03-1-45/AVIGATION EASEMENT
159E	ELMER S. FRIEDBERG & FAYE SCOTT	ALBANY COUNTY AIRPORT AUTHORITY	DEC. 9, 1993	L.2504 P. 835	---	18.00-2-13/AVIGATION EASEMENT
160E	MICHAEL F. & GERARD E. MANGIONE	ALBANY COUNTY AIRPORT AUTHORITY	JUNE 13, 1995	L.2485 P. 561	---	18.00-2-23/AVIGATION EASEMENT

NOTE:

THIS MAP AND LAND INVENTORY DEED TABULATION REPRESENTS A COMPILATION OF LANDS, PARCELS AND PROPERTIES OF THE ALBANY COUNTY AIRPORT AUTHORITY PREPARED FROM DEEDS OF RECORD, LAND SURVEY MAPS, LAND LEASE DOCUMENTS, HIGHWAY RIGHT-OF-WAY MAPS, AND OTHER LAND RECORD SOURCES PROVIDED TO L. SIPPERLY & ASSOCIATES, D.P.C.



L. SIPPERLY & ASSOCIATES, D.P.C.
ENGINEERS • SURVEYORS • LAND PLANNERS

AIRPORT PROPERTY MAP
EXHIBIT "A" - SHEET 9
LAND TABULATION

ALBANY COUNTY AIRPORT AUTHORITY
ALBANY, NEW YORK

LAST REVISED: 1/31/19

PARCEL NO.	GRANTOR	GRANTEE	DEED DATE	RECORDED	AREA (AC. +/-)	REMARKS
161L	DOUGLAS J. LUSTIG/METRO AIRLINES NE	ALBANY COUNTY AIRPORT AUTHORITY	DEC. 19, 1996	L.2571 P. 651	---	LEASE AGREEMENT - BROCKWAY AIR, INC. FACILITY
162	LORRAINE B. SYMANSKI	ALBANY COUNTY AIRPORT AUTHORITY	SEPT. 29, 1993	L.2496 P. 770	---	B.03-1-49 (146E)
163C	ALBANY COUNTY AIRPORT AUTHORITY	COUNTY OF ALBANY	JUNE 19, 1996	L.2573 P. 172	---	18.00-3-23.2, 24.12, & 24.22
164	MICHAEL F. & GERARD E. MANGIONE	ALBANY COUNTY AIRPORT AUTHORITY	APRIL 25, 1997	L.2578 P. 275	---	18.00-2-23
165	CHERE T. OYTT	ALBANY COUNTY AIRPORT AUTHORITY	JULY 2, 1997	L.2592 P. 391	---	18.00-4-22
166	CHARLES F., JR. & DOROTHY A. LITTLE	ALBANY COUNTY AIRPORT AUTHORITY	JULY 23, 1997	L.2583 P. 699	---	30.00-3-20
167	EDWARD F. DEXTRAZE	ALBANY COUNTY AIRPORT AUTHORITY	JULY 29, 1997	L.2583 P. 1087	---	30.00-3-19
168	CARLSBURY GONZALEZ	ALBANY COUNTY AIRPORT AUTHORITY	JULY 29, 1997	L.2583 P. 1122	---	30.00-3-25
169	1500 CENTRAL AVENUE ASSOCIATES	ALBANY COUNTY AIRPORT AUTHORITY	JULY 17, 1997	L.2584 P. 442	---	18.00-4-25.1
170E	KEN. C., RICH. J. & KEN. A. REBUSMEN	ALBANY COUNTY AIRPORT AUTHORITY	AUG. 15, 1995	L.2587 P. 876	---	PORTION OF 18.00-3-1/AVGATION EASEMENT
171	EILEEN NALL	ALBANY COUNTY AIRPORT AUTHORITY	OCT. 17, 1997	L.2589 P. 32	---	18.00-4-20
172	ANITA A. MILLER & FRED H. BARRON	ALBANY COUNTY AIRPORT AUTHORITY	NOV. 12, 1997	L.2590 P. 1035	---	30.00-3-23.1
173	ANITA A. MILLER & FRED H. BARRON	ALBANY COUNTY AIRPORT AUTHORITY	NOV. 12, 1997	L.2590 P. 1037	---	30.00-3-23.2
174E	GEORGE F. BUHRMASTER	ALBANY COUNTY AIRPORT AUTHORITY	OCT. 31, 1995	L.2592 P. 17	---	B.03-1-65/AVGATION EASEMENT/IN. 5544-95 R# NO. 0195 043368
174E	GEORGE F. BUHRMASTER	ALBANY COUNTY AIRPORT AUTHORITY	OCT. 31, 1995	L.2592 P. 21	---	B.03-1-65/AVGATION EASEMENT/IN. 5543-95 R# NO. 0195 043369
175E	EDWARD L. SR. & MAY. F. BUHRMASTER	ALBANY COUNTY AIRPORT AUTHORITY	OCT. 31, 1995	L.2592 P. 25	---	B.03-1-66/AVGATION EASEMENT/IN. 5542-95 R# NO. 0195 043367
176	VINCENT L. COLELLO	ALBANY COUNTY AIRPORT AUTHORITY	DEC. 31, 1997	L.2594 P. 145	---	30.00-3-22
177	ELIZABETH R. SORNBERGER	ALBANY COUNTY AIRPORT AUTHORITY	JAN. 21, 1998	L.2595 P. 388	---	18.00-2-38
178	ELIZABETH R. SORNBERGER	ALBANY COUNTY AIRPORT AUTHORITY	JAN. 20, 1998	L.2595 P. 392	---	18.00-2-40
179	WALTER W. HUBBARD	ALBANY COUNTY AIRPORT AUTHORITY	APRIL 10, 1998	L.2600 P. 735	---	30.00-3-29
180	NICHOLAS L. & VERA M. FRANGELLA	ALBANY COUNTY AIRPORT AUTHORITY	APRIL 27, 1998	L.2601 P. 905	---	B.03-1-48.1
181	BERNARD MARTINESE	ALBANY COUNTY AIRPORT AUTHORITY	JULY 22, 1998	L.2608 P. 35	---	18.00-3-7
182	DAVID P., JR. & CYNTHIA J. ALLEN	ALBANY COUNTY AIRPORT AUTHORITY	JULY 23, 1998	L.2608 P. 137	---	B.03-1-60
183E	JOSEPH C. & GLADYS M. DONAWICK	ALBANY COUNTY AIRPORT AUTHORITY	JULY 17, 1995	L.2609 P. 102	---	B.03-1-63/AVGATION EASEMENT/IN. 2291-95 R# NO. 0195 041604
184	WM. J. DONAWICK & BARR. J. SCHLEUSE	ALBANY COUNTY AIRPORT AUTHORITY	AUG. 31, 1998	L.2611 P.404/405	---	B.03-1-63
185	WASTA M. FINCH	ALBANY COUNTY AIRPORT AUTHORITY	SEPT. 18, 1998	L.2612 P. 584	---	18.00-3-11
186	THE VERDOY FIRE DEPARTMENT	ALBANY COUNTY AIRPORT AUTHORITY	SEPT. 28, 1998	L.2613 P. 208	---	18.00-2-26 & 27
187E	THE VERDOY FIRE ASSOCIATION	ALBANY COUNTY AIRPORT AUTHORITY	OCT. 31, 1995	L.2613 P. 485	---	18.00-2-26/AVGATION EASEMENT/IN. 5602-95 R# NO. 0195 043384
188E	THE VERDOY FIRE DEPARTMENT	ALBANY COUNTY AIRPORT AUTHORITY	OCT. 31, 1995	L.2613 P. 490	---	18.00-2-27/AVGATION EASEMENT/IN. 5603-95 R# NO. 0195 043385
189	JAMES F. & TAMMY L. FERRAIOLI	ALBANY COUNTY AIRPORT AUTHORITY	NOV. 6, 1998	L.2616 P. 549	---	30.00-3-17
190CE	ALBANY COUNTY AIRPORT AUTHORITY	TOWN OF COLONIE	NOV. 23, 1998	L.2618 P. 48	---	ENCUMBRANCE ON UTIL. EASEMENT/AGREEMENT- PORTION OF 72E
191	REBUSMEN'S FARM	ALBANY COUNTY AIRPORT AUTHORITY	JAN. 5, 1999	L.2620 P. 530	---	18.00-3-1
192	ROBIN P. ZOLLER	ALBANY COUNTY AIRPORT AUTHORITY	JAN. 13, 1999	L.2621 P. 19	---	30.00-3-18
193	BERNARD & MARY MARTINESE	ALBANY COUNTY AIRPORT AUTHORITY	FEB. 16, 1999	L.2623 P. 623	---	18.00-3-51
194	MARY MARTINESE	ALBANY COUNTY AIRPORT AUTHORITY	FEB. 16, 1999	L.2623 P. 625	---	18.00-3-46,47,48
195E	VILLAGE SQUARE OF PENNA., INC.	ALBANY COUNTY AIRPORT AUTHORITY	FEB. 27, 1998	L.2626 P. 481	---	PORTIONS OF 30.00-5-5 & 8/AVGATION EASEMENT
196E	PAUL C. & RUSSELL & NANCY RUSSELL	ALBANY COUNTY AIRPORT AUTHORITY	JULY 17, 1995	L. 2734 P. 684	0.7	B.03-1-58/AVGATION EASEMENT/IN. 2298-95 R# NO. 0195 041611
197E	CHARLES DENNISON	ALBANY COUNTY AIRPORT AUTHORITY	OCT. 29, 1999	L. 2642 P. 601	---	18.02-1-2/AVGATION EASEMENT/IN. 5541-95 R# NO. 0195 043366
198E	BET-LOU, INCORPORATED	ALBANY COUNTY AIRPORT AUTHORITY	OCT. 29, 1999	L. 2642 P. 599	---	18.00-2-25/AVGATION EASEMENT/IN. 5540-95 R# NO. 0195 043365
199E	ROBERT P. BUFE, II & JEAN M. BUFE	ALBANY COUNTY AIRPORT AUTHORITY	JUNE 21, 2000	L. 2658 P. 512	---	18.00-2-12/AVGATION EASEMENT/IN. 6323-95 R# NO. 0195 043722
200	CARLOS S. TEIXEIRA, ET. AL.	ALBANY COUNTY AIRPORT AUTHORITY	OCT. 9, 2001	L. 2692 P. 860	.7	B.03-1-68 FEE PARCEL PREVIOUSLY PARCEL NO. 200E
201	KAREN BAIKO, ET. AL.	ALBANY COUNTY AIRPORT AUTHORITY	DEC. 18, 2000	L. 2672 P. 50	0.5	18.00-3-15
202	KAYAN HOLDINGS, L.L.C.	ALBANY COUNTY AIRPORT AUTHORITY	JULY 24, 2000	L. 2661 P. 239	1.1	B.03-1-47

NOTE:

THIS MAP AND LAND INVENTORY DEED TABULATION REPRESENTS A COMPILATION OF LANDS, PARCELS AND PROPERTIES OF THE ALBANY COUNTY AIRPORT AUTHORITY PREPARED FROM DEEDS OF RECORD, LAND SURVEY MAPS, LAND LEASE DOCUMENTS, HIGHWAY RIGHT-OF-WAY MAPS, AND OTHER LAND RECORD SOURCES PROVIDED TO L. SIPPERLY & ASSOCIATES, D.P.C.



L. SIPPERLY & ASSOCIATES, D.P.C.
ENGINEERS • SURVEYORS • LAND PLANNERS

AIRPORT PROPERTY MAP
EXHIBIT "A" - SHEET 10
LAND TABULATION

ALBANY COUNTY AIRPORT AUTHORITY
ALBANY, NEW YORK

LAST REVISED: 1/31/19

PARCEL NO.	GRANTOR	GRANTEE	DEED DATE	RECORDED	AREA (AC. +/-)	REMARKS
203	VELLAND BROS., INC.	ALBANY COUNTY AIRPORT AUTHORITY	SEPT. 20, 2000	L. 2685 P. 582	0.4	30.00-3-16
204	VELLAND BROS., INC.	ALBANY COUNTY AIRPORT AUTHORITY	SEPT. 26, 2000	L. 2685 P. 586	1.6	30.00-3-15
205	DAVID J. KAISER & EILEEN JANET KAISER	ALBANY COUNTY AIRPORT AUTHORITY	JULY 3, 2001	L. 2684 P. 1079	2.5	18.00-2-37.12
206	DAVID J. KAISER & EILEEN JANET KAISER	ALBANY COUNTY AIRPORT AUTHORITY	JULY 3, 2001	L. 2684 P. 1079	---	18.00-2-37.2
207	DAVID J. KAISER & EILEEN JANET KAISER	ALBANY COUNTY AIRPORT AUTHORITY	JULY 3, 2001	L. 2684 P. 1079	---	18.00-2-33.2
208	DAVID J. KAISER & EILEEN JANET KAISER	ALBANY COUNTY AIRPORT AUTHORITY	JULY 3, 2001	L. 2684 P. 1079	---	18.00-2-36
209	DAVID J. KAISER & EILEEN JANET KAISER	ALBANY COUNTY AIRPORT AUTHORITY	JULY 3, 2001	L. 2684 P. 1079	---	18.00-2-32
210	DAVID J. KAISER & EILEEN JANET KAISER	ALBANY COUNTY AIRPORT AUTHORITY	JULY 3, 2001	L. 2684 P. 1079	---	18.00-2-31
211	DAVID J. KAISER & EILEEN JANET KAISER	ALBANY COUNTY AIRPORT AUTHORITY	JULY 3, 2001	L. 2684 P. 1079	---	18.00-2-33.12
212	NANCY A. KREUGLER	ALBANY COUNTY AIRPORT AUTHORITY	AUG. 21, 2001	L. 2689 P. 74	2.7	19.03-1-31
213	MARCELLO DeANGELIS	ALBANY COUNTY AIRPORT AUTHORITY	SEPT. 28, 2001	L. 2692 P. 1069	0.6	30.00-3-30
214	TIMOTHY H. BURNHAM, ET. AL.	ALBANY COUNTY AIRPORT AUTHORITY	DEC. 7, 2001	L. 2698 P. 831	0.4	30.00-3-28
215	JAMES G. & HELEN J. ESPEY	ALBANY COUNTY AIRPORT AUTHORITY	DEC. 6, 2001	L. 2698 P. 1067	0.5	30.00-3-27
216	CAIRNS MORTGAGE TRUST	ALBANY COUNTY AIRPORT AUTHORITY	JAN. 10, 2002	L. 2684 P. 1079	0.6	30.00-3-12.1
217	CAIRNS MORTGAGE TRUST	ALBANY COUNTY AIRPORT AUTHORITY	JAN. 10, 2002	L. 2684 P. 1079	0.9	30.00-3-12.2
218	CAIRNS MORTGAGE TRUST	ALBANY COUNTY AIRPORT AUTHORITY	JAN. 10, 2002	L. 2684 P. 1079	0.3	30.00-3-31.1
219	CAIRNS MORTGAGE TRUST	ALBANY COUNTY AIRPORT AUTHORITY	JAN. 10, 2002	L. 2684 P. 1079	0.8	30.00-3-31.2
220	CARL E. TOUHEY	ALBANY COUNTY AIRPORT AUTHORITY	JAN. 10, 2002	L. 2700 P. 848	10.1	30.00-3-13
221	RICHARD L. & ELLEN E. SORMBERGER	ALBANY COUNTY AIRPORT AUTHORITY	APRIL 10, 2002	L. 2707 P. 632	0.4	30.00-3-26
222	ALBANY COUNTY AIRPORT AUTHORITY	N.Y.S. DEPARTMENT OF TRANSPORTATION	APRIL 19, 2002	L. 2709 P. 431	---	NOTICE OF APPROPRIATION / ALBANY-SHAKER ROAD MAP NO. 225F-1, PARCELS 239 & 240
223	ALBANY COUNTY AIRPORT AUTHORITY	N.Y.S. DEPARTMENT OF TRANSPORTATION	APRIL 10, 2002	L. 2709 P. 432	---	NOTICE OF APPROPRIATION / ALBANY-SHAKER ROAD MAP NOS. 215, 226, 227, 228, 229, 230, & 231 PARCEL NOS. 194, 229, 241, 243, 244, 245, 246, 247, 276, 283 & 284
224	CONSOLIDATED FREIGHTWAYS CORPORATION OF DELAWARE	ALBANY COUNTY AIRPORT AUTHORITY	MARCH 22, 2002	L. 2709 P. 918	---	30.00-3-14 / 40' ACCESS EASEMENT AND RIGHT-OF-WAY
225	COUNCIL COMMERCE CORPORATION	ALBANY COUNTY AIRPORT AUTHORITY	SEPT. 23, 2002	L. 2720 P. 757	2.9	18.00-4-26
226	COUNCIL COMMERCE CORPORATION	ALBANY COUNTY AIRPORT AUTHORITY	SEPT. 23, 2002	L. 2720 P. 757	9.8	19.03-1-33
227	ALBANY COUNTY AIRPORT AUTHORITY	N.Y.S. DEPARTMENT OF TRANSPORTATION	APRIL 19, 2002	L. 2725 P. 345	---	NOTICE OF APPROPRIATION / ALBANY-SHAKER ROAD MAP NO. 265, PARCELS 307 & 308
228	A.H. HARRIS & SONS, INCORPORATED	ALBANY COUNTY AIRPORT AUTHORITY	DEC. 31, 2002	L. 2727 P. 841	10.5	18.00-2-50.1
229	TIMOTHY J. MNCIGUERRA, ET. AL.	ALBANY COUNTY AIRPORT AUTHORITY	FEB. 21, 2003	L. 2731 P. 162	71.4	30.00-5-9, TOGETHER WITH INGRESS AND EGRESS EASEMENT TO ALBANY-SHAKER ROAD
230	AMERICAN EAGLE AIRLINES, INC.	ALBANY COUNTY AIRPORT AUTHORITY	MAY 7, 2003	L. 2738 P. 639	4.83	18.00-2-51
231	R-19 ASSOCIATES	ALBANY COUNTY AIRPORT AUTHORITY	JUNE 13, 2003	L. 2740 P. 887	--	ASSIGNMENT OF GROUND LEASE
232	R-19 ASSOCIATES	ALBANY COUNTY AIRPORT AUTHORITY	JUNE 13, 2003	L. 2740 P. 923	1.3	---
233	CONSOLIDATED FREIGHTWAYS CORPORATION OF DELAWARE	ALBANY COUNTY AIRPORT AUTHORITY	JUNE 4, 2003	L. 2743 P. 340	6.4	30.00-3-14
234	TOWN OF COLONIE	ALBANY COUNTY AIRPORT AUTHORITY	NOV. 6, 2003	L. 2752 P. 940	0.5	FORMER AIRPORT LANE
235	TOWN OF COLONIE	ALBANY COUNTY AIRPORT AUTHORITY	NOV. 6, 2003	L. 2740 P. 923	1.9	FORMER PINE GROVE ROAD
236	DAVID J. KAISER & JUDY L. KAISER	ALBANY COUNTY AIRPORT AUTHORITY	DEC. 18, 2003	L. 2757 P. 738	4.1	18.00-2-42
237	COUNTY OF ALBANY	ALBANY COUNTY AIRPORT AUTHORITY	---	---	0.9	8.03-1-10
238	CARMEN CAMPBELL, ET. AL.	ALBANY COUNTY AIRPORT AUTHORITY	---	---	1.1	8.03-1-11
239	COUNTY OF ALBANY	ALBANY COUNTY AIRPORT AUTHORITY	---	---	20.0	FORMER ALBANY-SHAKER ROAD, FORMERLY PARCEL 115

NOTE:

THIS MAP AND LAND INVENTORY DEED TABULATION REPRESENTS A COMPILATION OF LANDS, PARCELS AND PROPERTIES OF THE ALBANY COUNTY AIRPORT AUTHORITY PREPARED FROM DEEDS OF RECORD, LAND SURVEY MAPS, LAND LEASE DOCUMENTS, HIGHWAY RIGHT-OF-WAY MAPS, AND OTHER LAND RECORD SOURCES PROVIDED TO L. SIPPERLY & ASSOCIATES, D.P.C.



L. SIPPERLY & ASSOCIATES, D.P.C.
ENGINEERS • SURVEYORS • LAND PLANNERS

AIRPORT PROPERTY MAP
EXHIBIT "A" - SHEET 11
LAND TABULATION

ALBANY COUNTY AIRPORT AUTHORITY
ALBANY, NEW YORK

LAST REVISED: 1/31/19

PARCEL NO.	GRANTOR	GRANTEE	DEED DATE	RECORDED	AREA (AC. +/-)	REMARKS
240	MJK LEASING, LLC	ALBANY COUNTY AIRPORT AUTHORITY	OCT. 13, 2004	L. 2782 P. 306	0.8	18.00-2-37.112
241	ALBANY COUNTY AIRPORT AUTHORITY	MJK LEASING, LLC	OCT. 13, 2004	L. 2787 P. 758	0.8	18.00-2-37.111
242	SANDRA M. D'AMANO & MATTHEW J. KELLY	ALBANY COUNTY AIRPORT AUTHORITY	DEC. 15, 2004	L. 2787 P. 1066	1.1	08.03-1-11
243	ANDREW S. EMPIE	ALBANY COUNTY AIRPORT AUTHORITY	MARCH 20, 2005	L. 2838 P. 395	0.8	8.03-1-56
244	GENERAL STEEL FABRICATORS, INC.	ALBANY COUNTY AIRPORT AUTHORITY	JUNE 15, 2005	L. 2804 P. 773	12.9	30.00-3-21 & 30.00-3-38
245	GENERAL STEEL FABRICATORS, INC.	ALBANY COUNTY AIRPORT AUTHORITY	JUNE 15, 2005	L. 2804 P. 777	0.1	30.00-3-36
246	ALBANY COUNTY AIRPORT AUTHORITY	COUNTY OF ALBANY	JULY 13, 2005	L. 2808 P. 584	24.0	LANDS TO BE INCLUDED IN AIRPORT LEASE AGREEMENT OLD ALBANY SHAKER ROAD & ALBANY-SHAKER ROAD
247	TOWN OF COLONIE	ALBANY COUNTY AIRPORT AUTHORITY	OCT. 11, 2005	L. 2819 P. 1090	1.1	30.00-3-79 (PORTION OF FORMER WATERLIET-SHAKER ROAD)
248E	FALLON REALTY, LLC	ALBANY COUNTY AIRPORT AUTHORITY	APRIL 21, 2006	L. 2843 P. 350	1.6	8.03-1-48.221/AVIGATION EASEMENT
249	FALLON REALTY, LLC	ALBANY COUNTY AIRPORT AUTHORITY	APRIL 21, 2006	L. 2843 P. 355	1.6	8.03-1-48.222
250E	INTERMAGNETIC GENERAL CORPORATION	ALBANY COUNTY AIRPORT AUTHORITY	AUG. 17, 2007	L. 2857 P. 1085	7.0	PORTION OF 18.00-3-24.2/AVIGATION EASEMENT
251	MARTHA E. JONES	ALBANY COUNTY AIRPORT AUTHORITY	APRIL 17, 2007	L. 2882 P. 1153	0.4	18.00-2-15
252	TOWN OF COLONIE	ALBANY COUNTY AIRPORT AUTHORITY	DEC. 7, 2007	L. 2906 P. 74	8.4	8.03-1-59
253	JENNIFER A. NEIL	ALBANY COUNTY AIRPORT AUTHORITY	JAN. 14, 2008	L. 2908 P. 756	1.1	08.03-1-47
253E	JENNIFER A. NEIL	ALBANY COUNTY AIRPORT AUTHORITY	JAN. 14, 2008	L. 2908 P. 756	1.1	08.03-1-47/AVIGATION EASEMENT
254E	JENNIFER A. NEIL	ALBANY COUNTY AIRPORT AUTHORITY	JAN. 14, 2008	L. 2908 P. 756	0.5	08.03-1-47/CONSERVATION EASEMENT
255	JENNIFER A. NEIL	ALBANY COUNTY AIRPORT AUTHORITY	JAN. 14, 2008	L. 2911 P. 164	0.6	08.03-1-50
256	NITA BUDLONG	ALBANY COUNTY AIRPORT AUTHORITY	MARCH 25, 2008	L. 2916 P. 728	12.0	18.00-3-23, 18.00-3-24.1 & 18.00-3-26
257	PAUL C. & NANCY RUSSELL	ALBANY COUNTY AIRPORT AUTHORITY	MAY 8, 2008	L. 2919 P. 836	7.8	08.03-1-58.2 (PORTION OF FORMER 08.03-1-58)
258	ALBANY COUNTY AIRPORT AUTHORITY	PAUL C. & NANCY RUSSELL	MAY 5, 2008	L. 2919 P. 717	8.4	08.03-1-58.1 (FORMERLY 08.03-1-59)
259	ALBANY COUNTY AIRPORT AUTHORITY	PAUL C. & NANCY RUSSELL	MAY 5, 2008	L. 2919 P. 717	1.1	08.03-1-58.1 (FORMERLY 08.03-1-11)
260E	PAUL C. & NANCY RUSSELL	ALBANY COUNTY AIRPORT AUTHORITY	MAY 8, 2008	L. 2919 P. 754	16.7	08.03-1-58.1/AVIGATION EASEMENT
261E	WINN LTD. - MARK FLEISCHER, G.M.	ALBANY COUNTY AIRPORT AUTHORITY	---	---	4.0	18.00-1-43.32/AVIGATION EASEMENT(PROPOSED)
262E	BRITISH AMERICAN, LLC	ALBANY COUNTY AIRPORT AUTHORITY	---	---	42.8	18.00-1-43.31/AVIGATION EASEMENT(PROPOSED)
263E	SHAKER RIDGE COUNTRY CLUB, INC.	ALBANY COUNTY AIRPORT AUTHORITY	---	---	170.6	18.00-1-43.1/AVIGATION EASEMENT(PROPOSED)
264E	ROSEWOOD SHAKER RIDGE, LLC	ALBANY COUNTY AIRPORT AUTHORITY	---	---	17.3	18.00-1-43.23/AVIGATION EASEMENT(PROPOSED)
265E	BRITISH AMERICAN, LLC	ALBANY COUNTY AIRPORT AUTHORITY	---	---	11.0	18.00-1-43.21/AVIGATION EASEMENT(PROPOSED)
266E	MEMORY GARDENS, INC.	ALBANY COUNTY AIRPORT AUTHORITY	---	---	194.3	18.00-1-44/AVIGATION EASEMENT(PROPOSED)
267E	BOGES	ALBANY COUNTY AIRPORT AUTHORITY	---	---	12.9	30.00-1-1/AVIGATION EASEMENT(PROPOSED)
268E	JOSEPH H. & FRANCES A. SCHMIDT	ALBANY COUNTY AIRPORT AUTHORITY	---	---	1.31	17.04-2-9/AVIGATION EASEMENT(PROPOSED)
269E	SUSAN A. LANZA	ALBANY COUNTY AIRPORT AUTHORITY	---	---	0.8	17.04-2-10/AVIGATION EASEMENT(PROPOSED)
270E	MICHAEL S. CERONE	ALBANY COUNTY AIRPORT AUTHORITY	---	---	0.7	17.04-2-17.1/AVIGATION EASEMENT(PROPOSED)
271E	MARIA A. GPOAL SISTLA	ALBANY COUNTY AIRPORT AUTHORITY	---	---	0.3	17.04-2-18/AVIGATION EASEMENT(PROPOSED)
272E	JOHN G. POTYRALA, JR.	ALBANY COUNTY AIRPORT AUTHORITY	---	---	0.4	17.04-2-19/AVIGATION EASEMENT(PROPOSED)
273E	LEONARD F. & FRANCES G. IVESON	ALBANY COUNTY AIRPORT AUTHORITY	---	---	0.4	17.04-2-20/AVIGATION EASEMENT(PROPOSED)
274E	WILLIAM J. & JEANNE B. KELLEY	ALBANY COUNTY AIRPORT AUTHORITY	---	---	0.4	17.04-2-21/AVIGATION EASEMENT(PROPOSED)
275E	STEPHEN & BARBARA QUAY	ALBANY COUNTY AIRPORT AUTHORITY	---	---	0.4	17.04-2-22/AVIGATION EASEMENT(PROPOSED)
276E	ANNE P. GALLOWAY & PETER E. PALMER	ALBANY COUNTY AIRPORT AUTHORITY	---	---	2.9	17.04-2-33.1/AVIGATION EASEMENT(PROPOSED)
277E	MICHAEL M. MASTROPIETRO	ALBANY COUNTY AIRPORT AUTHORITY	---	---	0.4	17.04-2-45/AVIGATION EASEMENT(PROPOSED)
278E	RONALD T. & SHIRLEY NEWTON PHILLIPS	ALBANY COUNTY AIRPORT AUTHORITY	---	---	0.4	17.04-2-48/AVIGATION EASEMENT(PROPOSED)
279E	GREGORY G. & KATHLEEN M. CHUDZINSKI	ALBANY COUNTY AIRPORT AUTHORITY	---	---	0.3	17.04-2-49/AVIGATION EASEMENT(PROPOSED)
280E	ORAG & BARBARA PAULSEN AND EVELYN POWERS	ALBANY COUNTY AIRPORT AUTHORITY	---	---	0.4	17.04-10-15/AVIGATION EASEMENT(PROPOSED)
281E	PATRICK J. BOLOGNA	ALBANY COUNTY AIRPORT AUTHORITY	---	---	0.8	17.04-10-16/AVIGATION EASEMENT(PROPOSED)

NOTE:

THIS MAP AND LAND INVENTORY DEED TABULATION REPRESENTS A COMPILATION OF LANDS, PARCELS AND PROPERTIES OF THE ALBANY COUNTY AIRPORT AUTHORITY PREPARED FROM DEEDS OF RECORD, LAND SURVEY MAPS, LAND LEASE DOCUMENTS, HIGHWAY RIGHT-OF-WAY MAPS, AND OTHER LAND RECORD SOURCES PROVIDED TO L. SIPPERLY & ASSOCIATES, DPC.



L. SIPPERLY & ASSOCIATES, D.P.C.
ENGINEERS • SURVEYORS • LAND PLANNERS

AIRPORT PROPERTY MAP
EXHIBIT "A" - SHEET 12
LAND TABULATION

ALBANY COUNTY AIRPORT AUTHORITY
ALBANY, NEW YORK

LAST REVISED: 1/31/19

PARCEL NO.	GRANTOR	GRANTEE	DEED DATE	RECORDED	AREA (AC.+/-)	REMARKS
282E	TERRENCE W. & BARBARA J. SHIELDS	ALBANY COUNTY AIRPORT AUTHORITY	---	---	0.5	17.04-10-17/AVIGATION EASEMENT(PROPOSED)
283E	MARK A. & ROBIN J. GREENE	ALBANY COUNTY AIRPORT AUTHORITY	---	---	0.4	17.04-10-18/AVIGATION EASEMENT(PROPOSED)
284E	MORINAGA & KIYOMI KAZUNOBO	ALBANY COUNTY AIRPORT AUTHORITY	---	---	0.4	17.04-10-19/AVIGATION EASEMENT(PROPOSED)
285E	JAMES R., Jr. & MAUREEN A. KELLY	ALBANY COUNTY AIRPORT AUTHORITY	---	---	0.4	17.04-10-23/AVIGATION EASEMENT(PROPOSED)
286E	RONALD E. RANELUCCI & MARY C. BARTON	ALBANY COUNTY AIRPORT AUTHORITY	---	---	0.4	17.04-10-23/AVIGATION EASEMENT(PROPOSED)
287E	LUIGI & MARIA S. DENITO	ALBANY COUNTY AIRPORT AUTHORITY	---	---	0.5	17.04-10-25/AVIGATION EASEMENT(PROPOSED)
288E	CHARLES DAVID & ROSEMARIE S. SCRODANOUS	ALBANY COUNTY AIRPORT AUTHORITY	---	---	0.8	17.04-10-26/AVIGATION EASEMENT(PROPOSED)
289E	FRED C. SPAGNOLA & MARY C. ZOBIE	ALBANY COUNTY AIRPORT AUTHORITY	---	---	0.6	17.04-10-27/AVIGATION EASEMENT(PROPOSED)
290E	PATRICIA E. FUSCO	ALBANY COUNTY AIRPORT AUTHORITY	---	---	0.4	17.04-10-28/AVIGATION EASEMENT(PROPOSED)
291	SHAKER RIDGE COUNTRY CLUB, INC.	ALBANY COUNTY AIRPORT AUTHORITY	OCT. 3, 2008	L. 2933 P. 589	4.2	18.00-1-43.4
292E	COUNTY OF ALBANY	ALBANY COUNTY AIRPORT AUTHORITY	FEB. 17, 2005	L. 2919 P. 541	---	SANITARY SEWER EASEMENT(ANN LEE HOME)
293	GUPTILL HOLDING CORPORATION	ALBANY COUNTY AIRPORT AUTHORITY	JUNE 5, 2008	L. 2932 P. 786	0.8	19.03-1-30
294	ALBANY CO. DEPT. OF MANAGEMENT & BUDGET	ALBANY COUNTY AIRPORT AUTHORITY	FEB. 28, 2011	L. 3003 P. 858	--	30.00-5-3/896 ALBANY SHAKER ROAD
295	698 SHAKER ROAD LLC & NALA PROPERTIES INC.	ALBANY COUNTY AIRPORT AUTHORITY	MAY 24, 2011	L. 3006 P. 67	0.2	30.00-5-2/898 ALBANY SHAKER ROAD
296	JEFFREY BUHRMASTER	ALBANY COUNTY AIRPORT AUTHORITY	FEB. 23, 2011	L. 2999 P. 1008	1.8	08.03-1-66/9 BUHRMASTER ROAD
297	GEORGE F. BUHRMASTER	ALBANY COUNTY AIRPORT AUTHORITY	MARCH 4, 2011	L. 3002 P. 401	1.4	08.03-1-65/15 BUHRMASTER ROAD (WITH LIFE ESTATE) CORRECTIVE DEED L. 3039, P. 558
298	GEORGE E. LONGHURST	ALBANY COUNTY AIRPORT AUTHORITY	---	---	1.4	08.03-1-62/29 BUHRMASTER ROAD (PENDING NOISE ACQUISITION)
299	PAUL & JEANNE PEZZULO	ALBANY COUNTY AIRPORT AUTHORITY	---	---	2.3	08.03-1-61/27 BUHRMASTER ROAD (PENDING NOISE ACQUISITION)
300	STANLEY B. & PATRICIA A. HICKS	ALBANY COUNTY AIRPORT AUTHORITY	---	---	--	18.00-3-19/6 KELLY ROAD (PENDING NOISE ACQUISITION)
301	GEORGE F. & JEFFREY G. BUHRMASTER	ALBANY COUNTY AIRPORT AUTHORITY	MARCH 29, 2011	L. 3002 P. 396	11.4	PORTION OF 08.04-1-52.1/4120 RIVER ROAD
302	FREDERICK P. & YVONNE L. SYNDER	ALBANY COUNTY AIRPORT AUTHORITY	---	---	--	18.00-2-41.1/42 SICKER ROAD (PENDING NOISE ACQUISITION)
303	MARGARET K. GIBSON, ET AL	ALBANY COUNTY AIRPORT AUTHORITY	FEB. 12, 2010	L. 2971 P. 862	1.9	18.00-2-11/1060 TROY-SCHENECTADY ROAD
304	JOHN K. ENGEL & EDWARD W. ENGEL, III	ALBANY COUNTY AIRPORT AUTHORITY	NOV. 5, 2009	L. 2963 P. 352	44.4	30.00-5-1/682 ALBANY-SHAKER ROAD
305E	MEMORY GARDENS, INC.	ALBANY COUNTY AIRPORT AUTHORITY	NOV. 24, 2010	L. 2993 P. 819	59.2	PORTION OF 18.00-1-44/AVIGATION EASEMENT
306L	ALBANY COUNTY AIRPORT AUTHORITY	CELLCO PARTNERSHIP	NOV. 29, 2010	L. 3000 P. 563	---	LEASE AGREEMENT - WITHIN TERMINAL BUILDING
307	ALBANY COUNTY AIRPORT AUTHORITY	JEFFREY G. & CHRISTINE BUHRMASTER	MARCH 28, 2011	L. 3002 P. 255	---	PORTION OF 8.03-1-63
308E	GEORGE & JEFFREY BUHRMASTER	ALBANY COUNTY AIRPORT AUTHORITY	MARCH 4, 2011	L. 3002 P. 390	19.3	PORTION OF 8.04-1-52.1/AVIGATION EASEMENT
309	TOWN OF COLONIE	ALBANY COUNTY AIRPORT AUTHORITY	AUG. 11, 2011	L. 3012 P. 808	1.9	19.14-3-10/25 UTICA AVENUE
310E	ALBANY COUNTY AIRPORT AUTHORITY	TOWN OF COLONIE	AUG. 11, 2011	L. 3012 P. 808	1.9	19.14-3-10/25 UTICA AVENUE/UTILITY EASEMENT
311	ALBANY COUNTY AIRPORT AUTHORITY	388 OLD NISKAYUNA ROAD LLC	OCT. 31, 2011	L. 3018 P. 159	2.5	18.00-3-51 & 48/388 OLD NISKAYUNA ROAD & 172 SICKER ROAD
312E	388 OLD NISKAYUNA ROAD LLC	ALBANY COUNTY AIRPORT AUTHORITY	OCT. 31, 2011	L. 3018 P. 159	2.5	18.00-3-51 & 48/AVIGATION EASEMENT
313E	JOHN K. ENGEL & EDWARD W. ENGEL, III	ALBANY COUNTY AIRPORT AUTHORITY	DEC. 18, 2013	L. 3086 P. 1000	38.46	30.00-3-77/AVIGATION EASEMENT
314	LATHAM POOL PRODUCTS, INC	ALBANY COUNTY AIRPORT AUTHORITY	FEB. 3, 2017	INST. R2017-3682	2.226	PORTION OF 30.00-3-13.1 (SEE FOLLOWING NOTE)
NOTE	ALBANY COUNTY AIRPORT AUTHORITY	ALBANY COUNTY AIRPORT AUTHORITY	FEB 6, 2017	INST. R2017-3683	12.28	PARCEL 314 MERGED WITH PARCEL 220 AND DESIGNATED AS TMLP 30.00-3-13.1
315L	COUNTY OF ALBANY	ALBANY COUNTY AIRPORT AUTHORITY	APRIL 12, 2017	COUNTY RESOLUTION	3.49	LAND LEASE AMENDMENT NO. 6-SE CORNER - INTERSECTION OF HERITAGE LANE & PETER J. DALESSANDRO BLVD.
316	ALBANY COUNTY AIRPORT AUTHORITY	N.Y.S. DEPARTMENT OF TRANSPORTATION	MARCH 26, 2018		5.911	NOTICE OF APPROPRIATION - MAP NO. 755 R-1, PARCEL NO. 881 RESERVES PRIOR AVIGATION EASEMENT OVER LANDS
317	ALBANY COUNTY AIRPORT AUTHORITY	N.Y.S. DEPARTMENT OF TRANSPORTATION	MARCH 26, 2018		6.061	NOTICE OF APPROPRIATION - MAP NO. 765 R-1, PARCEL NO. 892 RESERVES PRIOR AVIGATION EASEMENT OVER LANDS
318E	THE PEOPLE OF THE STATE OF NEW YORK	ALBANY COUNTY AIRPORT AUTHORITY	OCT. 11, 2018	INST. R2018-25900	---	PORTION OF 30.00-5-10.2/AVIGATION EASEMENT IN MAP NO. 768-C PARCEL NO. 895
319E	THE PEOPLE OF THE STATE OF NEW YORK	ALBANY COUNTY AIRPORT AUTHORITY	OCT. 11, 2018	INST. R2018-25901	---	PORTION OF 30.00-5-4/AVIGATION EASEMENT IN MAP NO. 749-C PARCEL NO. 875

NOTE:

THIS MAP AND LAND INVENTORY DEED TABULATION REPRESENTS A COMPILATION OF LANDS, PARCELS AND PROPERTIES OF THE ALBANY COUNTY AIRPORT AUTHORITY PREPARED FROM DEEDS OF RECORD, LAND SURVEY MAPS, LAND LEASE DOCUMENTS, HIGHWAY RIGHT-OF-WAY MAPS, AND OTHER LAND RECORD SOURCES PROVIDED TO L. SIPPERLY & ASSOCIATES, DPC.

LAST REVISED: 1/31/19



L. SIPPERLY & ASSOCIATES, D.P.C.
ENGINEERS • SURVEYORS • LAND PLANNERS

AIRPORT PROPERTY MAP
EXHIBIT "A" - SHEET 13
LAND TABULATION

ALBANY COUNTY AIRPORT AUTHORITY
ALBANY, NEW YORK